

Pre-Hung Unit Installation 1.3
Pre-Hung Venting Unit Installation 1.11
Pre-Hung Arch/Radius Unit Installation 1.19
Multi-Point Lock
Quick Tip Sheet & Instructions 1.21
Sill Pan Installation Instructions 1.29
Paintable & Stainable Aluminum Astragal
Site Installation Instructions 1.30
Multi-Point Shootbolt Paintable & Stainable
Astragal Installation Instructions..... 1.33
Coastal Astragal 2 Installation Instructions.. 1.36
Multi-Point Shootbolt
Coastal Astragal 2 Installation Instructions.. 1.39
French Door System Outswing Astragal
Security Cover Installation 1.42
Transom Installation Instructions 1.43
Elliptical Transom Casing Instructions 1.55
Adjusta-Fit 2 Prehanging Instructions 1.56
Sill Corner Seal Instructions 1.60
Adjustable Sill Cover Instructions 1.61
Grille Installation Instructions..... 1.63
SDL Bar Installation Instructions 1.65
Spring Hinge Instructions..... 1.70
Screen installation 1.71

THERMATRU
DOORS

Builder, Subcontractor or Supplier:

Please forward these instructions to the homeowner.

The application performance standards for these products may be governed by the International Residential Code, International Building Code and other state and jurisdictional requirements. Copies of performance ratings are available on our website at www.thermatru.com.

Installation Instructions for Pre-hung Door Systems

These installation instructions are designed to assist door installers who have an understanding of carpentry principles, and know how to properly and safely use power tools. The purpose of these instructions is to illustrate how to install a Therma-Tru door system using methods and materials that help eliminate water related leaks. If the directions are closely followed, the door system will have a long useful life with good resistance to rain related water intrusion problems.

These methods are “tried and true” They are used widely by builders and remodelers who are serious about managing and keeping water outside the home. Rather than eliminate any steps that may be unclear to you, please call 1-800-THERMATRU and ask for clarification. If you remain unclear, please seek more professional assistance with the installation.

Different parts of the country have different code requirements, which may not be covered in these instructions. The installer is responsible for insuring the installation complies with local codes. If you have unique code requirements that do not appear please contact 1-800-THERMATRU.

Required Tools & Materials: 2 & 6 foot Levels, Hammer, Putty Knives (firm & flexible), Framing Square, Caulking Gun, Sturdy Ladder, Shims, Tape Measure, High Quality Elastomeric or Polyurethane Sealant, Screw Gun/Drill -1/8 inch Drill Bit, Razor Knife, #2 & #3 Philips Bit, Stapler, Insulating Material, Eye Protection, Water Resistive Barrier, Flashing Material, #8 x 2-1/2 inch Exterior Grade Screws, & Optional Sill Pan.

Read all instructions before starting.

Therma-Tru Recommended Best Practices

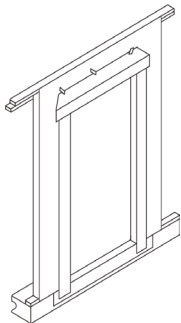

Use Water Resistive Barrier and Flexible Flashing: We recommend the use of a Water Resistive Barrier (WRB) applied to the exterior sheathing (OSB or other) and the use of an adhesive or flexible flashing product to seal around the opening. The WRB should be cut in the opening (follow manufacturer’s guidelines) with the head of the flap taped up, to be sealed later in Step 11. The flashing should be applied in an overlapping manner as shown, always working from the bottom up (follow manufacturer’s guidelines).

Use a Sill Pan: We recommend you first “dry fit” the sill pan in the opening, following the instructions furnished with the sill pan. Place the right and left sill pan ends tight against the sides of the opening. Check the center section for proper length and if necessary, cut with a hack saw or tin snips. Be sure to allow 2 inches of overlap at the joints.

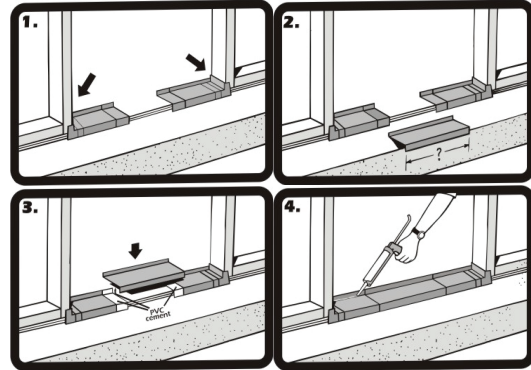

Note: Use only the PVC cement provided in the sill pan kit to glue the pieces together. The sill pan must be sealed to the sub-floor using an Elastomeric or Polyurethane sealant, but do not apply sealant to the bottom of the sill when using a sill pan.

Step 1: Check Door Unit.

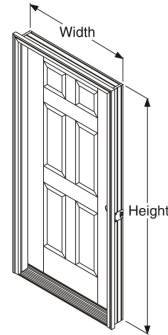

Check width and height.
Measure size of frame (width and height), not brickmould.
Remove cleats and packaging, but keep door fastened closed with transport clip. Do Not remove the transport clip until instructed to do so later in Step 7.

Step 2: Check and Prepare Opening.

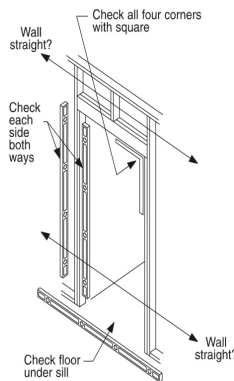

Is the opening the correct size for the door unit? Check it against the door frame size now, before installation. The opening should be frame height plus 1/2 inch, and frame width plus 1/2 inch to 3/4 inch. **Fix any problems now.**

Are the framing and walls **PLUMB**? Use a 6 foot level and check both sides of the opening, both ways (front to back and right to left). **Fix any problems now.**

Is the sub floor level and solid? **Provide a flat, level, clean weight bearing surface so the sill pan or sill can be properly caulked and sealed to the opening. Scrape sand or fill as required.**

Note: If additional floor covering clearance is required, attach the shim board to the sub floor. Be sure to caulk well under the shim board.

Is the opening square? Check all corners with a framing square. Double check by comparing diagonal measurements. **Fix any problems now.**

Pre-Hung Unit Installation

Step 2 cont.: Check and Prepare Opening.

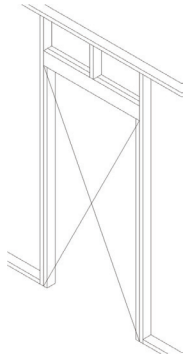

Check to be sure the framing walls around the opening are in the same plane. Do this by performing a “string test” for plumb.

String Test for Plumb: Attach a string diagonally across the opening from the outside, as shown. The string(s) should gently touch in the center, if not the opening is “out of plumb” by twice that distance and needs to be corrected. Flip the string over itself to check both planes. **Fix any problems now.**

*An “out of plumb” condition is one of the most common reasons door units leak air and water.

Step 3: Caulk the Sub Floor.

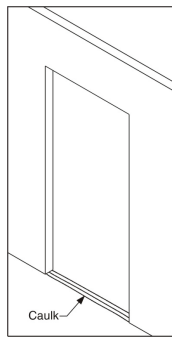

On the sub floor at opening, place 3 very large beads of sealant. Run beads full width of the opening.

Use Only Elastomeric or Polyurethane sealant.

Use an Entire Tube when Caulking along the Sub Floor.

Step 3A: Installation with a Sill Pan.

Place the right and left sill pan ends onto the caulk beads and tightly against the side of the opening.

Then, liberally coat the overlapped areas and the recessed areas of the pieces with the PVC cement provided. Place center section(s) in position and hold pieces together long enough to ensure a good bond.

For added protection, spread a bead of caulk along the glue joints and to prevent air infiltration, run a bead of caulk along the lower interior edge of the sill pan. Additional caulking could affect the performance of the sill pan.

Do Not Caulk the bottom of the Sill when using a sill Pan.

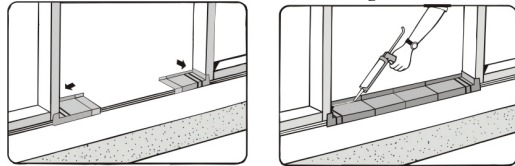

Step 3B: Installation without a Sill Pan.

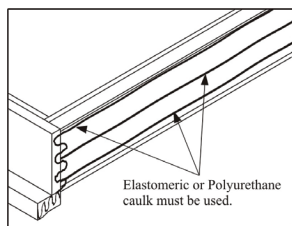

Lay the door unit on edge or face so that the bottom surface of the sill can be caulked. Place very large beads of caulk across the full width of the sill. Additionally, place beads of caulk along the junction of the sill and the jamb and on the bottom surface of the jambs and brickmould.

Note: If a sill extender is used, place a large bead of caulk at the junction of the extender and the sill approach.

Step 3 cont.: Caulking Back side of Brickmould.

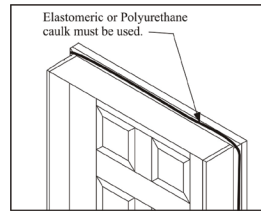

Important!

Apply sealant to the back side of brickmould around the entire perimeter of the door unit. A 1/2 – 5/8 inch bead of Elastomeric or Polyurethane caulk is essential.

Step 4: Place Unit in Opening and Temporarily Fasten.

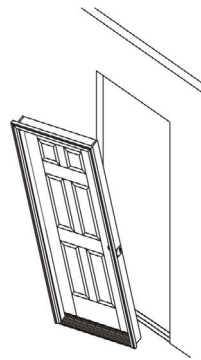

Lift the unit up. With top edge tilted away from opening, center the unit and place sill down onto sill pan or caulk beads and tilt into opening.

For all door unit configurations, note the hinge locations and mark those locations on the jamb faces near the door surfaces. Pre-drill 1/8 inch diameter holes at these locations for screw placement. A counter sink bit will help to conceal the screw heads.

Install screws in the center pre-drilled hole locations on both jambs to temporarily secure the unit in the place. Do not drive screws completely in at this time. Use #8 X 2-1/2 inch or 3 inch exterior grade screws.

Do Not Fasten through the Brickmould.

Step 4 cont.: Plumb Hinge Side Jamb.

Work from side of the door that is weather-stripped.

Use a 6 foot level and plumb the hinge side jamb both ways (right to left and inside to outside).

Place screws through the hinge side jamb into the studs, at each remaining hinge location, as shown in the diagrams. Use #8 X 2-1/2 inch or 3 inch exterior grade screws.

Do Not drive the screws completely in at this time.

For Single or Double Doors, place screws at each hinge location, so shims can be placed behind hinges above screws. The screws will keep the shims from falling down while adjustments are being made.

For Sidelite units, fasten the jamb on the hinge side of the door.

For Double Door and Patio Units, fasten the fixed or passive side of the unit first.

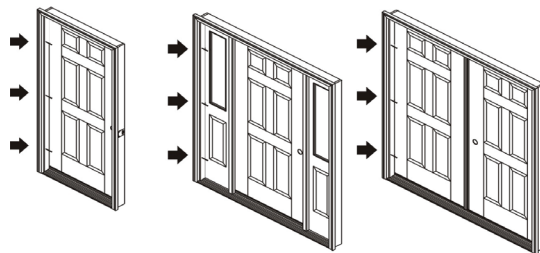

Single Unit

Sidelite Unit

Double Unit

Step 5: Shim at Hinge Locations and Secure Hinge Jamb.

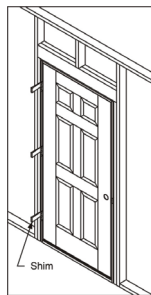

Leave door fastened and closed with transport clip.

Shim above screws, behind each hinge location, between the opening and the jamb.

Use a 6 foot level and re-check hinge jamb to ensure it is **plumb** and straight.

Finish driving screws tight in the middle first then top and bottom last.

Step 6: Adjust Rest of Frame and Fasten.

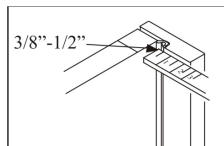

From the weatherstrip side of the door, check weatherstrip margins and contact.

Make frame adjustments so the weatherstrip contacts the door surface equally at the top, middle and bottom, an even 3/8 inch to 1/2 inch when fully closed.

Secure the lock side jamb with #8 X 2-1/2 or 3 inch screws through the pre-drilled holes at the top and bottom. **Do Not** drive screws tight at this time.

From the swing side of the door, shim above the screw locations and make adjustments so the margins between the door and frame are even top to bottom.

Note: For Double Doors, make adjustments that effect the alignment, margins and weatherstrip contact between the doors. Also follow the Astragal Site Package Instructions for details on properly setting the slide bolt hole locations.

Step 6 cont.: Adjust Rest of Frame and Fasten.



Re-check everywhere for plumb and square, and an even weatherstrip contact.

Finish driving all screws tight.

Step 7: Remove Transport Clip and Open Door.

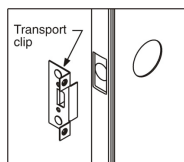

Remove the transport clip.

Open and close door to check for smooth operation.

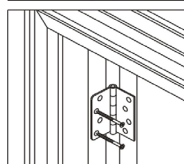

With the door open, drill 1/8 inch diameter pilot holes in the top hinge in the 2 screw hole locations closest to the weatherstrip. Then, install the #10 X 2-1/2 inch screws (provided) through the hinge, into the stud, to anchor the door frame and prevent sagging.

Step 7 cont.: Remove Transport Clip and Open Door.

For Sidelite and Patio Units: With the door open, check to determine if the 2-1/2 inch long hinge screws were pre-installed in the hinges. If not, drill 1/8 inch diameter pilot holes and install the long hinge screws in the hole locations closest to the weatherstrip.

Close the door and carefully shim between the jamb and the opening behind the adjustable strike plate area.

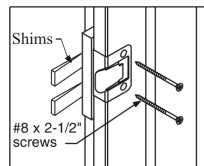

Then open the door and drill 1/8 inch dia. pilot holes and install the #8 X 2-1/2 inch screws (provided) through the strike plate holes to secure the lock side jamb and provide security.

Adjust strike plate in or out for proper weatherstrip contact and door operation, then finish tightening screws.

Step 8: Adjust Sill.

Your door unit may have an adjustable threshold cap. When properly adjusted, it should be snug and slightly difficult to pull a dollar bill out from under the door when it is fully closed. The dollar bill should be able to be removed without tearing.

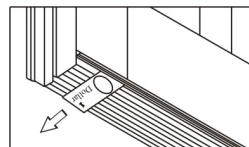

This check should be performed at each adjustment screw location.

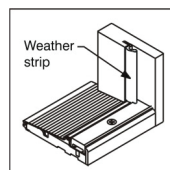

After adjusting the threshold cap, ensure that the weatherstrip is **flush** with the top of the threshold cap. Trim as necessary.

Step 9: Install Corner Seal Pads – Inswing units Only.

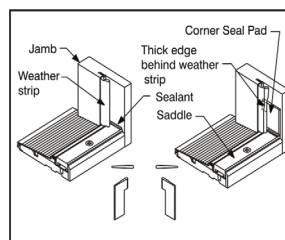

Apply sealant (Polyurethane or Elastomeric) at the joint where the threshold cap meets the door jambs.

Remove the self-stick paper from the corner seal pads and apply to the door jamb, with the **bottom** lined up evenly with the top of the threshold cap. When the pad is correctly installed, the tab is on top and the narrow part is on the bottom.

The bottom of the pad is the same width of the threshold cap to help with alignment during installation.

Step 10: Additional Frame Anchoring.

If sill is prepared for anchoring screws, place appropriate screws through the sill into the sub floor where needed. (Primarily on Outswing Sills)

We recommend that you provide additional frame anchoring as shown here. Certain states or jurisdictions, notably Florida and the coast of Texas, have specific installation requirements and may require installation in strict accordance with the product approval for a specific product. You should always check with the local authority having jurisdiction for any specific installation requirements that may apply. Specific product approval installation instructions, including those required for the High Velocity Zone (HVHZ), are also available at www.thermatru.com

Pre-Hung Unit Installation

Step 10 cont.: Additional Frame Anchoring.

Doors with Sidelites:

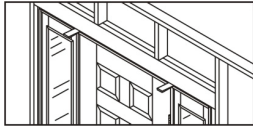

Shim above mull post or jamb separating doors and sidelites. Screw through the frame into the header, adjacent to the shims.

Double doors:

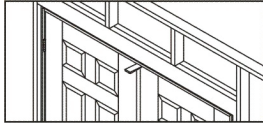

Place *temporary* shims above the center of the head frame, where doors meet. Pre-drill and insert a screw through frame into header, then remove the temporary shims.

Patio Doors:

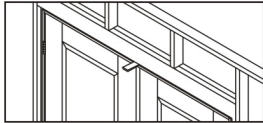

Shim above the mull post(s). Pre-drill and insert a screw through the frame into the header, at either side of the post.

Step 11: Weatherproof, Finish and Maintain.

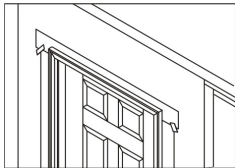

Provide and maintain a properly installed cap or head flashing to protect top of surfaces from **Water intrusion** and damage. Tape and properly seal the top flap of the Water Resistive Barrier (WRB) over the head flashing.

Caulk around **entire** “weather” side of unit, sealing along the brickmould to the flashing material or siding and seal all joints between the jamb and moldings.

Seal the joints between the exterior hardware trim and the door face to **prevent** air and water infiltration.

Place and set galvanized finish nails through the brickmould around the perimeter. Use exterior grade screws if you are installing a storm door to the brickmould. Countersink all fasteners and cover with exterior grade putty.

Add insulation material to the cavity between the opening and the unit to reduce **air infiltration** and **heat transfer**.

All Therma-Tru Steel doors must be finished within several days of the installation date for continued warranty coverage. For Fiberglass doors the finishing requirement is within 6 months of installation.

Paint or stain according to Therma Tru Finishing instructions. Do Not paint or stain the weatherstrip, it is “friction-fit” and easily removed for painting or staining.

All 6 sides of the doors must be finished. For out-swing doors the sides, top and bottom must be inspected and maintained as regularly as all other surfaces.

All bare wood surfaces such as the door frame exposed to weather should be primed and painted or stained and top coated **within** two weeks of exposure for best performance.

Maintain or replace sealants and finishes as soon as any deterioration is evident. For semi-gloss or glossy paint or clear coats, do this when the surface becomes dull or rough. More severe climates and exposures will require more frequent maintenance.

Access our website www.thermatru.com for printable versions of the installation and Same Day Stain finishing instructions and to view our Troubleshooting video for minor installation issues and adjustments.

Finishing Instructions.

Work only when temperatures are between 50° and 90°F and with humidity less than 85%. Do not finish in direct sunlight.

Steel and Smooth-Star® Doors:

To paint Doors: Clean first with mild detergent and water or use a TSP (tri-sodium phosphate) solution. Rinse well and allow to dry completely. Mask off hardware, glass and remove weatherstripping before painting. Use high-quality acrylic latex house paint, following manufacturer’s directions for application. Use exterior grade finishes for outside surfaces. Paint edges and exposed ends of door.

To Paint Doorlite Frames: Remove any excess glass glazing sealant by first spraying with a window cleaner or water. Use a single edge razor blade to score the glazing along the edge of the frame. Holding the razor blade at a 45 degree angle, scrape glazing from glass. Wipe remaining residue off with window cleaner or mineral spirits. Clean frame with a mild detergent and water, or use a TSP solution. Rinse well and allow to dry completely. Mask off glass. Prime door lite frames with an alkyd- or acrylic-based primer. Allow primer to dry before applying finish paint coats. Use high-quality acrylic latex house paint, following manufacturer’s application instructions. Use exterior grade finishes for outside surfaces.

Classic-Craft® and Fiber-Classic® Doors:

To Finish Doorlite Frames and Panel Inserts:

Remove any excess glazing sealant by first spraying with a window cleaner or water. Use a single edge razor blade to score the glazing along the edge of the frame. Holding the razor blade at a 45° angle, scrape glazing from glass. Wipe remaining residue off with window cleaner or mineral spirits. Mask off glass. Paint or stain using same materials as for the door. (See below).

To Paint Doors:

Clean first with mild detergent and water or use a TSP (tri-sodium phosphate) solution. Rinse well and allow to dry completely. Prime with an alkyd- or acrylic-based primer. Allow primer to dry completely, then paint with acrylic latex house paint, following paint manufacturer’s application instructions. Use a primer and paint that are compatible. Use exterior grade finishes for outside surfaces. Paint edges and exposed ends of door.

To Stain Doors:

Clean first with a clean cloth and mineral spirits and allow to air dry or wash door with mild detergent and water, or a TSP (tri-sodium phosphate) solution. Rinse well and allow to dry completely. For stained surfaces, we **only** recommend the use of the stain and clear coat products found in the **Therma-Tru Same-Day Stain™ Finishing Kit**. Apply stain with a rag. The longer the stain is left to “setup” before wiping off, the darker the color will be. Using a clean rag, wipe off the stain to the color shade you desire. Remove any excess stain from the panel grooves with the foam brush provided; allow the stain to dry for at least 6 hours before applying topcoat. See **Therma-Tru Same-Day Stain™ Finishing Kit** instructions for complete details.

Warning:

Modification or machining of this product can release wood dust, a substance known to the State of California to cause cancer.

THERMATRU®
DOORS

Constructor, subcontratista o proveedor:

Entregue estas instrucciones al propietario.

Los estándares de rendimiento de aplicación para estos productos están regidos por el Código Residencial Internacional, el Código de Construcción Internacional y por otras normas estatales o jurisdiccionales. Las copias de las clasificaciones de rendimiento se encuentran disponibles en nuestro sitio Web en www.thermatru.com.

Instrucciones de instalación para sistemas de puertas prefabricadas

Estas instrucciones de instalación están diseñadas para ayudar a los instaladores de puertas que tienen nociones principios de carpintería y saben cómo usar herramientas eléctricas de manera adecuada y segura. El propósito de estas instrucciones es demostrar la manera de instalar un sistema de puertas Therma-Tru mediante el uso de métodos y materiales que ayudan a eliminar las filtraciones relacionadas con el agua. Si se siguen cuidadosamente las instrucciones, el sistema de puertas tendrá una vida útil prolongada con una buena resistencia a los problemas relacionados con el agua de lluvia.

Estos métodos están "comprobados". Son usados frecuentemente por los constructores y remodeladores preocupados por mantener el agua fuera de las casa. En caso de que estas instrucciones no aclaren sus dudas, no se salten ninguno de los, y llame al 1-800-THERMATRU y pida aclaraciones. Si todavía tiene dudas, busque más ayuda profesional para la instalación.

Las diferentes regiones del país cuentan con diferentes requisitos de códigos, que pueden no estar cubiertos por estas instrucciones. El instalador es el responsable de asegurar que la instalación cumpla con los códigos locales. Si se aplican códigos únicos que no aparecen, póngase en contacto con el 1-800-THERMATRU.

Herramientas y materiales necesarios: niveles de 2' y 6', martillo, espátulas (rígidas y flexibles), escuadra de enmarcar, pistola para calafateo, escalera resistente, calzas, cinta métrica, sellador elastomérico o de poliuretano de alta calidad, pistola atornilladora o taladro: taladro con broca para taladro de 1/8", navaja, puntas Philips #2 y #3, engrapadora, material de aislamiento, gafas de protección, barrera resistente al agua, material tapajuntas, tornillos para exteriores #8 x 2-1/2" y revestimiento para alféizar

Lea todas las instrucciones antes de comenzar.

Mejores prácticas recomendadas por Therma-Tru

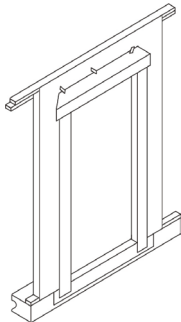

Use barreras resistentes al agua y tapajuntas flexibles: Recomendamos el uso de barreras resistentes al agua (WRB, por sus siglas en inglés) aplicadas al revestimiento exterior (OSB u otras) y el uso de productos adhesivos o de tapajuntas flexibles para sellar el perímetro de la abertura. Se debe cortar la WRB en la abertura (siga las pautas del fabricante) con el cabezal de la lengüeta cubierta con cinta adhesiva, para sellarla después en el paso 11. Se debe aplicar el tapajuntas de manera superpuesta, como se muestra, siempre comenzando desde la parte inferior hacia arriba (siga las pautas del fabricante).

1994-2009 Therma Tru Corp. All rights reserved.
Therma-Tru Doors is an operating company of Fortune Brands, Inc.

Issued 4/11 Rev.G Part# MSDRIST65

Use un revestimiento para alféizar: recomendamos que primero compruebe que el revestimiento para alféizar cabe en la abertura siguiendo las instrucciones incluidas con éste. Coloque los extremos derecho e izquierdo del revestimiento para alféizar contra los costados de la abertura. Compruebe que la sección central tenga el largo adecuado y, de ser necesario, córtela con una sierra de mano o tijeras para hojalata. Asegúrese de dejar 5,08 centímetros de superposición para las uniones.

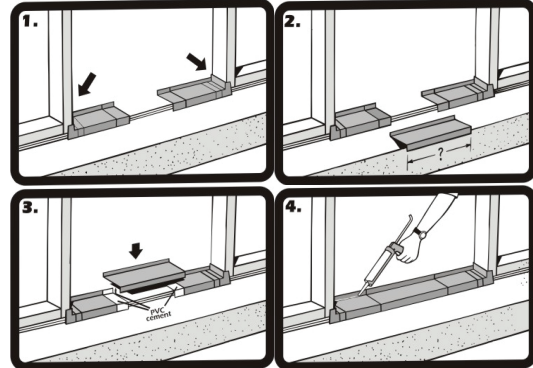

Nota: Use sólo el cemento PVC incluido en el kit de revestimiento para alféizar para unir las piezas. El alféizar se debe sellar al subsuelo con un sellador elastomérico o de poliuretano, pero no aplique sellador a la parte inferior del alféizar usando un revestimiento para alféizar

Paso 1: revise la puerta.

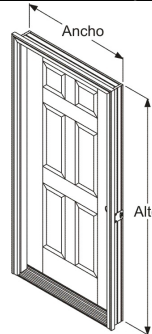

Revise el ancho y alto.

Mida el tamaño del marco (ancho y alto), no de la moldura.

Retire las tablas y el empaque, pero mantenga la puerta fijamente cerrada con el sujetador para transporte. No retire el sujetador para transporte hasta que se le indique hacerlo más adelante en el paso 7.

Paso 2: revise y prepare la abertura.

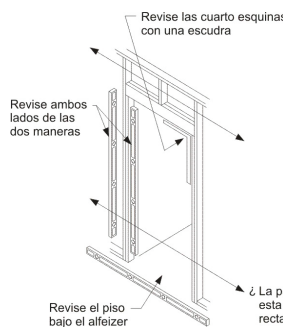

¿La abertura es del tamaño correcto para la puerta? Compárela con el tamaño del marco de la puerta ahora, antes de la instalación. La abertura debe tener el alto del marco más 1,27 cm y el ancho del marco más 1,27 a 1,91 cm. **Resuelva cualquier problema en este momento.**

¿Los marcos y las paredes están A PLOMO? Use un nivel de 6 pies y revise ambos lados de la abertura, de las dos maneras (del frente hacia atrás y de derecha a izquierda). **Resuelva cualquier problema en este momento.**

¿El subsuelo está nivelado y sólido? **Proporcione una superficie plana, nivelada y limpia que soporte el peso, de manera que se pueda aplicar masilla de calafateo y sellar de forma adecuada el revestimiento para alféizar o el alféizar a la abertura. Raspe, lije o rellene según se necesite.**

Nota: si se necesita una separación adicional de la cobertura del piso, fije la tabla de calza al subsuelo. Asegúrese de calafatear bien bajo la tabla de calza.

¿La abertura está a escuadra? Revise todas las esquinas con una escuadra de enmarcar. Revise dos veces comparando las medidas diagonales. **Resuelva cualquier problema en este momento.**

Pre-Hung Unit Installation

Paso 2, cont.: revise y prepare la abertura.

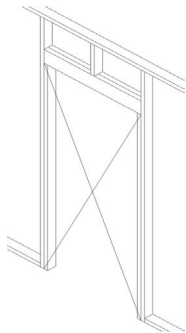

Asegúrese de que las paredes que enmarcan el perímetro de la abertura están en el mismo plano. Hágalo realizando una prueba con un cordel para verificar que está a plomo.

Pruebe con cordel para verificar que está a plomo: Coloque un cordel que cruce diagonalmente la abertura desde el exterior, como se muestra. Los cordeles se deben tocar suavemente en el centro, de lo contrario, la abertura está "fuera de plomo" por el doble de dicha distancia y se debe corregir. Voltee el cordel sobre sí mismo para verificar ambos planos. **Resuelva cualquier problema en este momento.**

*El estado "fuera de plomo" es una de las razones más comunes por las que las puertas sufren fugas de aire y agua

Paso 3: Aplique masilla de calafateo en el subsuelo.

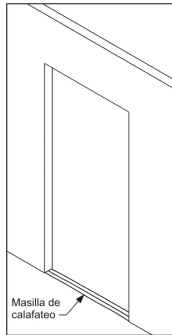

Coloque 3 cordones de sellador muy grandes en el subsuelo de la abertura. Extienda los cordones hasta alcanzar el ancho total de la abertura.

Use **sólo** sellador elastomérico o de poliuretano.

Use un tubo completo para calafatear a lo largo del subsuelo.

Paso 3A: Instalación con un revestimiento para alféizar.

Coloque los extremos derecho e izquierdo del revestimiento para alféizar en los cordones de masilla de calafateo y firmemente contra el costado de la abertura.

Luego, cubra generosamente las áreas superpuestas de las piezas con el cemento PVC incluido. Coloque las secciones centrales en posición y mantenga juntas las piezas el tiempo suficiente para asegurar la formación de una buena adhesión.

Para obtener protección adicional, esparza un cordón de masilla de calafateo a lo largo de las uniones de adhesivo y, para evitar la filtración de aire, extienda un cordón de masilla de calafateo a lo largo del borde interior inferior del revestimiento para alféizar. Colocar masilla de calafateo adicional puede afectar el rendimiento del revestimiento para alféizar.

No calafatee la parte inferior del alféizar cuando use un revestimiento para alféizar

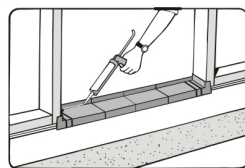
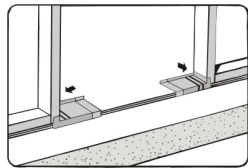

Paso 3B: Instalación sin un revestimiento para alféizar.

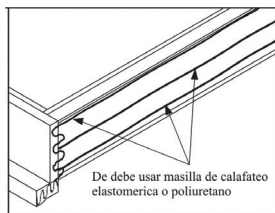

Coloque la puerta sobre su borde o frente, de manera que se pueda calafatear la superficie inferior del alféizar. Coloque cordones de masilla de calafateo muy grandes a lo largo de todo el ancho del alféizar. Además, coloque cordones de masilla de calafateo a lo largo de la unión del alféizar y la jamba y en la superficie inferior de las jambas y las molduras.

Nota: si usa una extensión para alféizar, coloque un cordón de masilla de calafateo grande en la unión de la extensión y la entrada del alféizar.

Paso 3, cont.: calafateo de la parte posterior de la moldura.

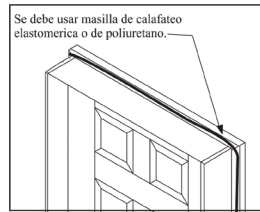

¡Importante!

Aplique sellador a la parte posterior de la moldura, en todo el perímetro de la puerta. Es fundamental colocar un cordón de masilla de calafateo elastomérica o de poliuretano de 1,27 a 1,59 cm.

Paso 4: coloque la unidad en la abertura y fije temporalmente.

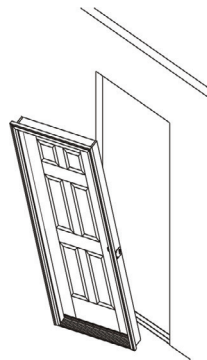

Levante la unidad. Incline el borde superior alejándolo de la abertura y centre la unidad; coloque el alféizar en el revestimiento para alféizar o los cordones de masilla de calafateo e inclínelo hacia la abertura.

Tenga presente la ubicación de las bisagras para todas las configuraciones de las puertas y márquelas en el frente de las jambas, cerca de las superficies de la puerta. Pretaladre orificios de 0,32 cm de diámetro en estas ubicaciones para colocar los tornillos. Puede ocultar las cabezas de los tornillos si usa una broca para avellanar.

Instale los tornillos en la ubicación del orificio pretaladrado central de ambas jambas para asegurar la unidad **temporalmente** en el lugar. No coloque los tornillos completamente en este momento. Use tornillos para exteriores de #8 X 2-1/2 ó 3 pulgadas.

No los apriete a través de la moldura.

Paso 4, cont.: coloque a plomo el lado de las bisagras de la jamba.

Comience a trabajar desde el lado con burletes de la puerta.

Use un nivel de 6 pies y coloque a plomo el lado de las bisagras de las jambas de las dos maneras (de derecha a izquierda y del interior al exterior).

Haga pasar los tornillos a través del lado de las bisagras de la jamba hasta los montantes, en cada una de las ubicaciones de las bisagras restantes como se muestra en los diagramas. Use tornillos para exteriores de #8 X 2-1/2 ó 3 pulgadas.

No coloque los tornillos completamente en este momento.

En el caso de las puertas simples y dobles, coloque los tornillos en cada una de las ubicaciones de las bisagras, de manera que se pueda colocar las calzas tras las bisagras y sobre los tornillos. Los tornillos evitarán que las calzas se caigan mientras se realizan ajustes.

En el caso de las unidades con vidrieras laterales, apriete la jamba en el lado de las bisagras de la puerta.

En el caso de las unidades de puerta doble y para patio, apriete primero el lado fijo o pasivo de la unidad.

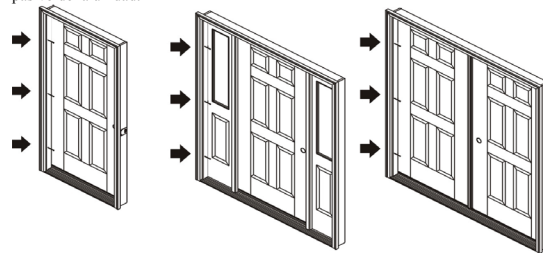

Unidad simple

Unidad con vidriera lateral

Unidad doble

Paso 5: coloque calzas en las ubicaciones de las bisagras y asegure la jamba con bisagras.

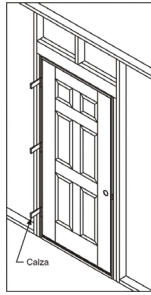

Deje la puerta fija y cerrada con el sujetador para transporte.

Coloque calzas sobre los tornillos, detrás de cada ubicación de las bisagras, entre la abertura y la jamba.

Use un nivel de 6 pies y vuelva a verificar la jamba con bisagras para asegurarse de que está a plomo y recta.

Termine de apretar primero los tornillos del medio, luego los de la parte superior y finalmente los de la parte inferior.

Paso 6: ajuste el resto del marco y apriete.

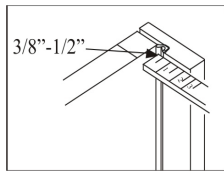

Verifique los márgenes y contactos de los burletes desde el lado de la puerta que los tiene.

Ajuste el marco de manera que los burletes hagan contacto con la superficie de la puerta de la misma manera en la parte superior, la parte del medio y la parte inferior, una distancia pareja de 0,95 a 1,27 centímetros cuando está completamente cerrada.

Asegure la jamba del lado del seguro con tornillos de #8 X 2-1/2 ó 3 pulgadas a través de los orificios pretaladrados en la parte superior e inferior. **No** apriete los tornillos en este momento.

Coloque calzas sobre las ubicaciones de tornillos desde el lado de apertura de la puerta y realice ajustes de manera que los márgenes entre la puerta y el marco queden pareja desde la parte superior a la inferior.

Nota: en el caso de las puertas dobles, realice ajustes que tengan efecto sobre la alineación, los márgenes y el contacto de los burletes entre las puertas. Además, siga las instrucciones del paquete del sitio de Astragal para obtener detalles sobre la configuración adecuada de la ubicación de los orificios para el cerrojo.

Paso 6, cont.: ajuste el resto del marco y apriete.



Vuelva a verificar que todos los lugares estén a plomo y a escuadra y que los burletes estén en contacto de manera pareja

Termine de apretar todos los tornillos.

Paso 7: retire el sujetador para transporte y abra la puerta.

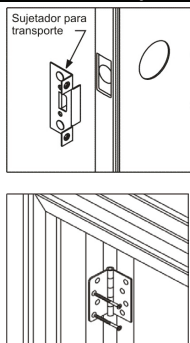

Retire el sujetador para transporte.

Abra y cierre la puerta para verificar que funciona correctamente

Con la puerta abierta, taladre orificios guía de 0,32 cm de diámetro en la bisagra superior, en las 2 ubicaciones de los orificios para tornillos más cercanas al burlete. Luego, instale los tornillos de #10 X 2-1/2 pulgadas (incluidos) a través de la bisagra, pasando por el montante, para anclar el marco de la puerta y evitar que quede suelta.

Paso 7, cont.: retire el sujetador para transporte y abra la puerta.

Para unidades con vidriera lateral y para patio: con la puerta abierta, verifique y determine si se instalaron previamente los tornillos para bisagra largos de 2-1/2" en las bisagras. De no ser así, taladre orificios guía de 0,32 cm de diámetro e instale los tornillos largos para bisagra en las ubicaciones de orificio más cercanas al burlete.

Cierre la puerta y coloque calzas cuidadosamente entre la jamba y la abertura tras el área de la cerradura de seguridad ajustable.

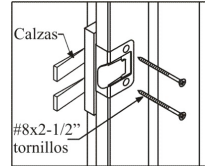

Luego, abra la puerta y taladre orificios guía de 0,32 cm de diámetro e instale los tornillos de #8 X 2-1/2 pulgadas (incluidos) a través de los orificios de la cerradura para asegurar la jamba del lado del seguro y proporcionar seguridad

Ajuste la cerradura hacia adentro o afuera para que entre en contacto con el burlete y la puerta funcione de manera adecuada, luego, termine de apretar los tornillos.

Paso 8: ajuste el alféizar.

Es posible que su puerta tenga una cubierta para umbral ajustable. Cuando se ajusta de manera adecuada, la puerta debe quedar apretada y debe ser ligeramente difícil jalar un billete de un dólar por debajo de ella cuando está bien cerrada. Se debe poder retirar el billete de un dólar sin rasgarlo.

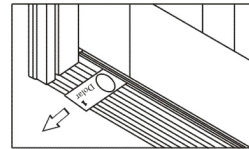

Esta verificación se debe realizar en cada ubicación de tornillo de ajuste.

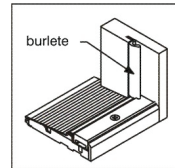

Después de ajustar la cubierta para umbral, asegúrese de que el burlete está *al ras* con la parte superior de la cubierta para umbral. Recorte si es necesario.

Paso 9: instale las almohadillas de sellado para esquinas: sólo para unidades de apertura hacia adentro.

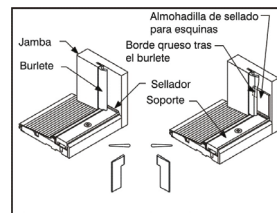

Aplique sellador (elastomérico o de poliuretano) en la unión entre la cubierta para umbral y las jambas de la puerta.

Retire el papel autoadhesivo de las almohadillas de sellado para esquinas y aplíquelas a la jamba de la puerta, alineando de forma pareja la parte inferior con la parte superior de la cubierta para umbral.

Cuando la almohadilla se instala correctamente, la lengüeta se encontrará encima y la parte estrecha abajo.

La parte inferior de la almohadilla tiene el mismo ancho que la cubierta para umbral, para ayudar a alinearlas durante la instalación.

Paso 10: anclaje adicional del marco.

Si el alféizar cuenta con preparación para tornillos de anclaje, coloque los tornillos adecuados a través del alféizar y hasta el subsuelo de ser necesario. (Principalmente en alféizares para apertura hacia afuera).

Le recomendamos proporcionar anclaje adicional al marco, como lo mostramos aquí. Algunos estados o jurisdicciones, como es el caso de Florida y la costa de Texas, cuentan con normativa de instalación específica y pueden requerir que la instalación se haga de estricto acuerdo con la aprobación del producto para un producto específico. Usted debe siempre verificar con la autoridad local que tenga jurisdicción si existe normativa de instalación específica que pueda aplicarse. Disponemos de instrucciones específicas de instalación para aprobación de productos, lo que incluye aquellos requeridos para la zona de huracanes de alta velocidad, en www.thermatru.com

Pre-Hung Unit Installation

Paso 10, cont.: anclaje adicional del marco.

Puertas con vidrieras laterales:

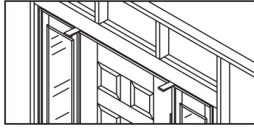

Coloque calzas sobre los listones verticales o las jambas de puerta que separan las puertas de las vidrieras laterales. Atornille a través del marco hasta el dintel, junto a las calzas.

Puertas dobles:

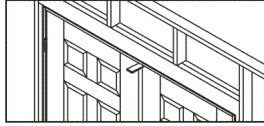

Coloque calzas *temporales* sobre el centro del marco del dintel, donde se unen las puertas. Pretaladre e inserte un tornillo, a través del marco, en el dintel y luego retire las calzas temporales.

Puertas para patio:

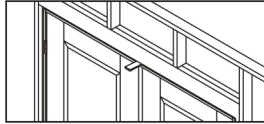

Coloque calzas sobre los listones verticales, pretaladre e inserte un tornillo, a través del marco, en el dintel, a cada lado de los listones.

Paso 11: deje a prueba de intemperie, aplique un acabado y dé mantenimiento.

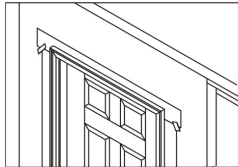

Proporcione y mantenga una cubierta o un tapajuntas del dintel adecuadamente instalados para proteger la parte superior de las superficies del **ingreso de agua** y del daño. Coloque cinta adhesiva y selle de manera adecuada la parte superior de la lengüeta de la barrera resistente al agua (WRB) sobre el tapajuntas del dintel.

Calafatee alrededor de **todo** el lado expuesto al clima de la unidad, sellando a lo largo de la moldura hasta el material de tapajuntas o los revestimientos y selle todas las uniones entre las jambas y las molduras.

Selle las uniones entre el reborde de los accesorios exteriores y el frente de la puerta para **evitar** la filtración de aire y agua.

Coloque y ajuste clavos galvanizados para acabado a través de la moldura, alrededor del perímetro. Use tornillos para exteriores si está instalando una contrapuerta en la moldura. Avellane todos los sujetadores y cúbralos con masilla para exteriores.

Añada material de aislamiento a la cavidad entre la abertura y la unidad, a fin de reducir la **filtración de aire** y la **transferencia de calor**.

Todas las puertas de acero Therma Tru deben finalizarse dentro de los días siguientes a la fecha de la instalación para una adecuada cobertura de la garantía. Para puertas de fibra de vidrio, el acabado debe darse dentro de los 6 meses después de la instalación.

Pinte o tiña de acuerdo con las instrucciones de acabado de Therma Tru. No pinte ni tiña el burlete, está ajustado para la fricción y se retira fácilmente para pintar o teñir.

Las puertas **de apertura hacia fuera** deben tener acabados en todos los bordes, los costados, la parte superior y la parte inferior. Inspeccione y dé mantenimiento a estos bordes con la misma regularidad que con todas las demás superficies.

Se debe dar acabado a los 6 lados de las puertas. Para las puertas que se abren para afuera, los lados, la parte superior y la parte inferior deben inspeccionarse y conservarse con la misma regularidad que las otras superficies.

Dé mantenimiento o reemplace los selladores y acabados tan pronto el deterioro sea evidente. En el caso de la pintura brillante o semibrillante y de las capas transparentes, hágalo cuando la superficie se vuelva opaca o áspera. Los climas y las exposiciones más rigurosos necesitarán de mantenimiento más frecuente.

Ingrese a nuestro sitio Web www.thermatru.com para obtener versiones imprimibles de la instalación e instrucciones para el acabado el mismo día y para consultar nuestro video de solución de problemas sobre problemas y ajustes menores de la instalación.

Instrucciones para el acabado:

Trabaje sólo cuando las temperaturas se encuentren entre 10 y 32,2° C y la humedad sea menor a un 85%. No aplique acabados bajo la luz solar directa.

Puertas de acero y Smooth-Star®

Para pintar puertas: primero limpie con un detergente suave y agua o use una solución de TSP (fosfato trisódico). Enjuague bien y deje secar completamente. Proteja los accesorios, los vidrios y los burletes antes de pintar. Use pintura látex de casas de alta calidad y siga las instrucciones del fabricante para su aplicación. Use acabados para exteriores para las superficies exteriores. Pinte los bordes y los extremos expuestos de la puerta.

Para pintar marcos de vidrieras para puertas: Primero retire cualquier exceso de sellador de esmalte para vidrios rociando con un limpiador de ventanas o agua. Use una navaja de un solo filo para hacer cortes en el esmalte a lo largo del borde del marco. Raspe el esmalte del vidrio sosteniendo la cuchilla de la navaja en un ángulo de 45 grados. Retire el residuo restante con un limpiador de ventanas o aguarrás mineral. Limpie el marco con un detergente suave y agua o use una solución de TSP. Enjuague bien y deje secar completamente. Proteja el vidrio. Aplique una pintura base de resina alquídica o acrílica a los marcos de vidrieras. Deje secar la pintura base antes de aplicar las capas de pintura de acabado. Use pintura látex de casas de alta calidad y siga las instrucciones del fabricante para su aplicación. Use acabados para exteriores para las superficies exteriores.

Puertas Classic-Craft® y Fiber-Classic®:

Para dar acabado a marcos de vidrieras para puertas y a accesorios para paneles: primero retire cualquier exceso de sellador de esmalte rociando con un limpiador de ventanas o agua. Use una navaja de un solo filo para hacer cortes en el esmalte a lo largo del borde del marco. Raspe el esmalte del vidrio sosteniendo la cuchilla de la navaja en un ángulo de 45°. Retire el residuo restante con un limpiador de ventanas o aguarrás mineral. Proteja el vidrio. Pinte o tiña usando los mismos materiales de la puerta. (Consulte abajo.)

Para pintar puertas:

primero limpie con un detergente suave y agua o use una solución de TSP (fosfato trisódico). Enjuague bien y deje secar completamente. Aplique una pintura base de resina alquídica o acrílica. Deje que la pintura base se seque completamente, luego, pinte con pintura látex de casas siguiendo las instrucciones del fabricante para su aplicación. Use una pintura base y una pintura que sean compatibles. Use acabados para exteriores para las superficies exteriores. Pinte los bordes y los extremos expuestos de la puerta.

Para teñir puertas:

primero limpie con un paño limpio y aguarrás mineral y deje secar al aire o lave la puerta con un detergente suave y agua o una solución de TSP (fosfato trisódico). Enjuague bien y deje secar completamente. En el caso de las superficies teñidas, sólo recomendamos el uso de tintes y productos de capas transparentes que se encuentran en el **kit para acabado Therma-Tru Same-Day Stain™**. Aplique el tinte con un paño. Mientras más tiempo se deje el tinte para "asentarse" antes de limpiarlo, más oscuro será el color. Use un paño limpio para limpiar el tinte hasta lograr el tono del color que desea. Retire cualquier exceso de tinte de las grietas del panel con la brocha de espuma que se incluye. Deje secar el tinte durante al menos 6 horas antes de aplicar una capa superior. Consulte las instrucciones del kit para acabado Therma-Tru Same-Day Stain™ para obtener información detallada.

Advertencia:

La modificación o el mecanizado de este producto puede liberar polvo de madera, una sustancia que el Estado de California reconoce como causante de cáncer.

THERMA-TRU®
DOORS

Builder, Subcontractor or Supplier:

Please forward these instructions to the homeowner.

Therma-Tru® certified door systems and Therma-Tru® door systems that require product approval (typically for coastal applications) may require special assembly, components and installation. Always refer to the certified system requirements and product approval assembly and installation drawings on our website for these applications.

Building codes can vary by Jurisdiction, County and/or State. Always check for any specific assembly or installation that may be required by Code in your area.

Installation Instructions for Vented Sidelite Door Systems

These installation instructions are designed to assist door installers who have an understanding of carpentry principles, and know how to properly and safely use power tools. The purpose of these instructions is to illustrate how to install a Therma-Tru® door system using methods and materials that help eliminate air infiltration and water related leaks. If the directions are closely followed, the door system will have a long useful life with good resistance to air and water intrusion problems.

These methods are “tried and true” They are used widely by builders and remodelers who are serious about managing and keeping water outside the home. Rather than eliminate any steps that may be unclear to you, please call 1-800-THERMATRU and ask for clarification. If you remain unclear, please seek more professional assistance with the installation.

Required Tools & Materials: 2 & 6 foot Levels, Hammer, Putty Knives (firm & flexible), Framing Square, Caulking Gun, Sturdy Ladder, Shims, Tape Measure, High Quality Elastomeric or Polyurethane Sealant, Screw Gun/Drill -1/8 inch Drill Bit, Razor Knife, #2 & #3 Philips Bit, Stapler, Insulating Material, Eye Protection, Water Resistive Barrier, Flashing Material, #8 x 2-1/2 inch Exterior Grade Screws, & Optional Sill Pan.

The door unit is large, heavy and can be cumbersome to lift, move and position. Use safe lifting techniques and a helper(s) to assist you with installation, in order to prevent personal injury and damage to the unit, and to help facilitate proper installation.

Read all instructions before starting.

Therma-Tru® Recommended Best Practices

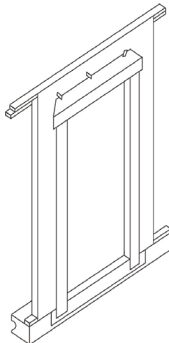

Use Water Resistive Barrier and Flexible Flashing: We recommend the use of a Water Resistive Barrier (WRB) applied to the exterior sheathing (OSB or other) and the use of an adhesive or flexible flashing product to seal around the opening. The WRB should be cut in the opening (follow manufacturer’s guidelines) with the head of the flap taped up, to be sealed later in Step 13. The flashing should be applied in an overlapping manner as shown, always working from the bottom up (follow manufacturer’s guidelines).

Use a Sill Pan: We recommend you first “dry fit” the sill pan in the opening, following the instructions furnished with the sill pan. Place the right and left sill pan ends tight against the sides of the opening. Check the center section for proper length and if necessary, cut with a hack saw or tin snips. Be sure to allow 2 inches of overlap at the joints.

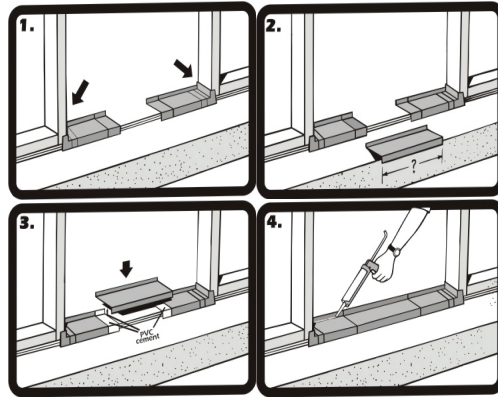

Note: Use only the PVC cement provided in the sill pan kit to glue the pieces together. The sill pan must be sealed to the sub-floor using an Elastomeric or Polyurethane sealant, but do not apply sealant to the bottom of the sill when using a sill pan.

Step 1: Check Door Unit.

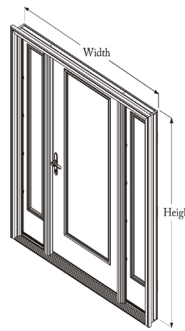

Check width and height.

Measure size of frame (width and height), not brickmould.

Remove cleats and packaging, but keep door fastened closed with transport clip. Do not remove the transport clip until instructed to do so later in Step 9.

Step 2: Check and Prepare Opening.

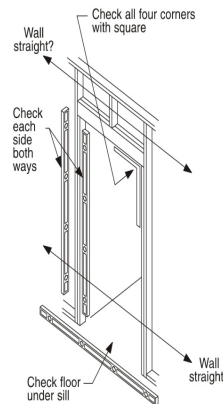

Is the opening the correct size for the door unit? Check it against the door frame size now, before installation. The opening should be frame height plus 1/2 inch, and frame width plus 1/2 inch to 3/4 inch. **Fix any problems now.**

Are the framing and walls **PLUMB**? Use a 6 foot level and check both sides of the opening, both ways (front to back and right to left). **Fix any problems now.**

Is the sub floor level and solid? **Provide a flat, level, clean weight bearing surface so the sill pan or sill can be properly caulked and sealed to the opening. Scrape sand or fill as required.**

Note: If additional floor covering clearance is required, attach the shim board to the sub floor. Be sure to caulk well under the shim board.

Is the opening square? Check all corners with a framing square. Double check by comparing diagonal measurements. **Fix any problems now.**

Pre-Hung Venting Unit Installation

Step 2 cont.: Check and Prepare Opening.

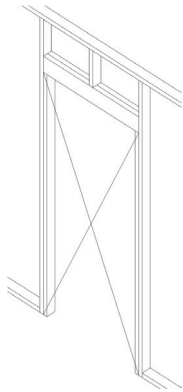

Check to be sure the framing walls around the opening are in the same plane. Do this by performing a “string test” for plumb.

String Test for Plumb: Attach a string diagonally across the opening from the outside, as shown. The string(s) should gently touch in the center, if not the opening is “out of plumb” by twice that distance and needs to be corrected. Flip the string over itself to check both planes. **Fix any problems now.**

*An “out of plumb” condition is one of the most common reasons door units leak air and water.

Step 3: Caulk the Sub Floor.

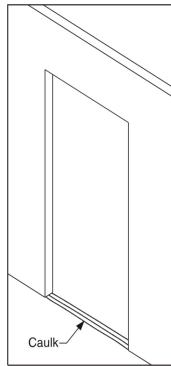

On the sub floor at opening, place 3 very large beads of sealant. Run beads full width of the opening.

Use Only Elastomeric or Polyurethane sealant.

Use an Entire Tube when Caulking along the Sub Floor.

Step 3A: Installation with a Sill Pan.

Place the right and left sill pan ends onto the caulk beads and tightly against the side of the opening.

Then, liberally coat the overlapped areas and the recessed areas of the pieces with the PVC cement provided. Place center section(s) in position and hold pieces together long enough to ensure a good bond.

For added protection, spread a bead of caulk along the glue joints and to help prevent air infiltration, run a bead of caulk along the lower interior edge of the sill pan. Additional caulking could affect the performance of the sill pan.

Do Not Caulk the bottom of the Sill when using a sill Pan.

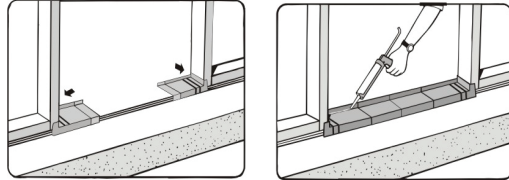

Step 3B: Installation without a Sill Pan.

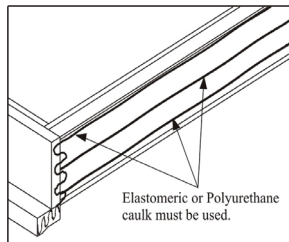

Lay the door unit on edge or face so that the bottom surface of the sill can be caulked. Place very large beads of caulk across the full width of the sill. Additionally, place beads of caulk along the junction of the sill and the jamb and on the bottom surface of the jamb and brickmould.

Note: If a sill extender is used, place a large bead of caulk at the junction of the extender and the sill approach.

Step 3 cont.: Caulking Back side of Brickmould.

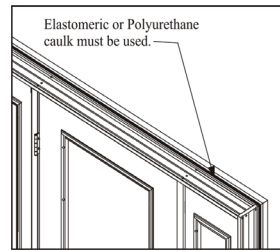

Important!

Apply sealant to the back side of brickmould around the entire perimeter of the door unit. A 1/2 – 5/8 inch bead of Elastomeric or Polyurethane caulk is essential.

Step 4: Place Unit in Opening and Temporarily Fasten.

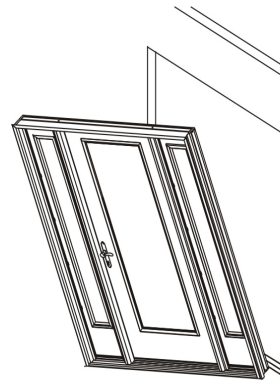

Lift the unit up. With top edge tilted away from opening, center the unit and place sill down onto sill pan or caulk beads and tilt into opening. For all door unit configurations, note the hinge locations and mark those locations on the jamb faces near the door surfaces. Pre-drill 1/8 inch diameter holes at these locations and through the head jamb adjacent to the mullions, over the active sidelites. A counter sink bit will help to conceal the screw heads.

Install screws in the center pre-drilled hole locations on both jambs to temporarily secure the unit in the place. Do not drive screws completely in at this time. Use #8 X 2-1/2 inch or 3 inch exterior grade screws.

Do Not Fasten through the Brickmould.

Step 5: Plumb and Fasten Side Head Mull Post .

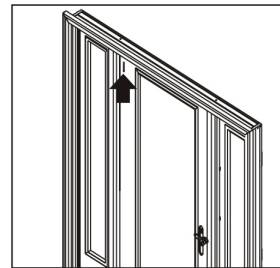

Use a 6 foot level and plumb the hinge side mullion both ways (right to left and inside to outside). Place a screw through the pre-drilled hole in the head jamb at the hinge side mullion.

Do not drive the screw completely in at this time.

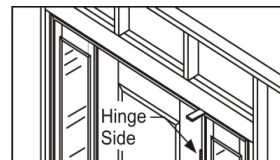

Shim directly over hinge side mull post. Using a 6 foot level, recheck hinge mull post to ensure it is plumb and straight. Finish driving screw tight.

Note: When installing a French door with active sidelites, first set the hinge mullion for the passive door. For details on properly setting the astragal slide bolt hole locations, follow the instructions in the astragal site pack.

Step 6: Adjust and Fasten Lock Side Mull Post.

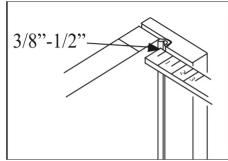

Adjust lock side mull post so that the weatherstrip contacts the door surface equally at the top, middle, and bottom, an even 3/8" – 1/2" when fully closed. Place a screw through the pre-drilled hole in the head jamb at the lock side mullion.

Do Not drive the screw completely in at this time.

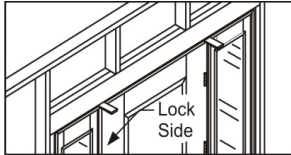

Shim directly over lock side mull post. Recheck lock mull post to ensure weatherstrip contact is even top to bottom. Finish driving screw tight.

Step 7: Adjust and Secure Side Jamb.

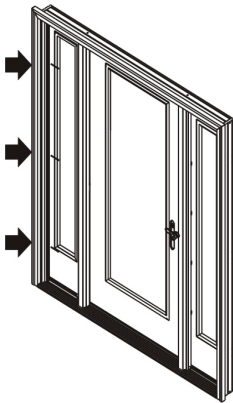

Adjust the sidelite hinge jamb on the hinge mull side of the unit to obtain even weatherstrip contact top to bottom at the lock side of the sidelite. Place a screw through the hinge side jamb, into the stud, at each remaining hinge location.

Do not drive the screws completely in at this time.

Shim above the screws behind each hinge location between the opening and the jamb and make adjustment so the margin between the sidelite and mullion are even top to bottom. This margin will be slightly larger than the margin at the door. Recheck sidelite hinge jamb to ensure weatherstrip contact is even top to bottom. Finish driving

screws tight.

Repeat the previous step on the sidelite hinge jamb on the lock mull side of the unit.

Step 8: (French Door) Temporary Shim at Head Jamb.

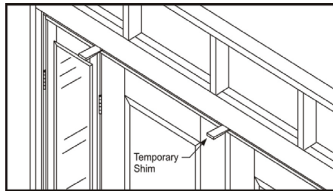

When installing a French door with active sidelites, place temporary shims above the center of the head frame, where doors meet. Pre-drill and insert a screw through frame into header, then remove the temporary shims.

Step 9: Remove Transport Clip and Open Door.

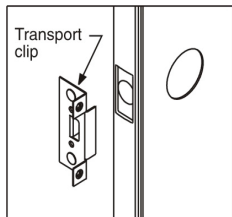

Remove transport clips. Confirm door and sidelites operate properly.

Make adjustments as needed.

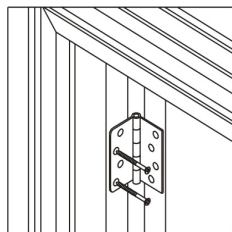

With sidelites open, drill 1/8" diameter pilot holes and install the long hinge screws in the hinge locations closest to the weatherstrip. Do this for all hinges.

Step 10: Adjust Sill.

Your door unit has adjustable threshold caps. When properly adjusted, it should be snug and slightly difficult to pull a dollar bill out from under the door and sidelites when fully closed. The dollar bill should be able to be removed without tearing.

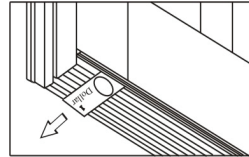

This check should be performed at each adjustment screw location on each active threshold cap.

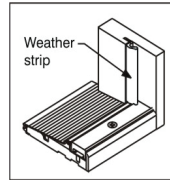

After adjusting the threshold cap, ensure that the weatherstrip is *flush* with the top of the threshold cap. Trim as necessary.

Step 11: Install Corner Seal Pads – Inswing units Only.

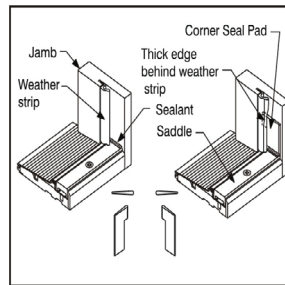

Apply sealant (Polyurethane or Elastomeric) at the joint where the threshold cap meets the jambs and mull posts.

Remove the self-stick paper from the corner seal pads and apply to the jamb or mull post, with the *bottom* lined up evenly with the top of the threshold cap. When the pad is correctly installed, the tab is on top and the narrow part is on the bottom.

The bottom of the pad is the same width of the threshold cap to help with alignment during installation. Corner pads must be installed on **both** sides of each active opening.

Pre-Hung Venting Unit Installation

Step 12: Weatherproof, Finish and Maintain.

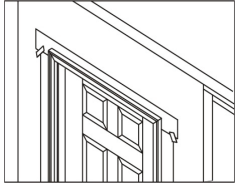

Provide and maintain a properly installed drip cap or head flashing to protect top of surfaces from **Water intrusion** and damage. Tape and properly seal the top flap of the Water Resistive Barrier (WRB) over the head flashing.

Caulk around **entire** "weather" side of unit, sealing along the brickmould to the flashing material or siding and seal all joints between the jambs and moldings.

Seal the joints between the exterior hardware trim and the door face to **prevent** air and water infiltration.

Place and set galvanized finish nails through the brickmould around the perimeter. Use exterior grade screws if you are installing a storm door to the brickmould. Countersink all fasteners and cover with exterior grade putty.

Add insulation material to the cavity between the opening and the unit to reduce **air infiltration** and **heat transfer**.

All Therma-Tru® Fiberglass doors must be finished within 6 months of the installation date for continued warranty coverage.

Paint or stain according to Therma-Tru® Finishing instructions. Do Not paint or stain the weatherstrip, it is "friction-fit" and easily removed for painting or staining.

All 6 sides of the doors must be finished. All door edges must be inspected and maintained as regularly as all other surfaces.

All bare wood surfaces such as the door frame exposed to weather should be primed and painted or stained and top coated **within** two weeks of exposure for best performance.

Maintain or replace sealants and finishes as soon as any deterioration is evident. For semi-gloss or glossy paint or clear coats, do this when the surface becomes dull or rough. More severe climates and exposures will require more frequent maintenance.

Access our website www.thermatru.com for printable versions of the installation and Same-Day® Stain finishing instructions and to view our Troubleshooting video for minor installation issues and adjustments.

Finishing Instructions.

Work only when temperatures are between 50° and 90°F and with humidity less than 85%. Do not finish in direct sunlight. Work only in well-ventilated areas.

Smooth-Star® Doors:

To Paint Doors: Clean first with mild detergent and water or use a TSP (trisodium phosphate) solution. Rinse well and allow to dry completely. Mask off hardware, glass and remove weatherstripping before painting. Use high quality acrylic latex house paint, following manufacturer's directions for application. Use exterior grade finishes for outside surfaces. Paint edges and exposed ends of door.

To Paint Doorlite Frames: Remove any excess glass sealant by first spraying with a window cleaner or water. Use a single edge razor blade to score the sealant along the edge of the frame. Holding the razor blade at a 45 degree angle, scrape the sealant from glass. Wipe remaining residue off with window cleaner or mineral spirits. Clean glass frame with a mild detergent and water, or use a TSP solution. Rinse well and allow to dry completely. Mask off glass. Prime glass frames with an alkyd- or acrylic-based primer. Allow primer to dry before applying finish paint coats. Use high-quality acrylic latex house paint, following manufacturer's application instructions. Use exterior grade finishes for outside surfaces.

Fiber-Classic® Doors:

To Finish Doorlite Frames and Panel Inserts:

Remove any excess glass sealant by first spraying with a window cleaner or water. Use a single edge razor blade to score the sealant along the edge of the frame. Holding the razor blade at a 45° angle, scrape the sealant from glass. Wipe remaining residue off with window cleaner or mineral spirits. Clean glass frame with a mild detergent and water, or use a TSP solution. Rinse well and allow to dry completely. Mask off glass. Prime glass frames with an alkyd- or acrylic-based primer. Allow primer to dry before applying finish paint coats. Use high-quality acrylic latex house paint, following manufacturer's directions for application and dry time. Use exterior grade finishes for outside surfaces.

To Paint Doors:

Clean first with mild detergent and water or use a TSP (tri-sodium phosphate) solution. Rinse well and allow to dry completely. Prime with an alkyd- or acrylic-based primer. Allow primer to dry completely, then paint with acrylic latex house paint, following paint manufacturer's application instructions. Use a primer and paint that are compatible. Use exterior grade finishes for outside surfaces. Paint edges and exposed ends of door.

To Stain Doors:

Clean first with a clean cloth and mineral spirits and allow to air dry or wash door with mild detergent and water, or a TSP (tri-sodium phosphate) solution. Rinse well and allow to dry completely. For stained surfaces, we only recommend the use of the stain and clear coat products found in the **Therma-Tru® Same-Day® Stain Finishing Kit**. Apply stain with a rag. The longer the stain is left to "setup" before wiping off, the darker the color will be. Using a clean rag, wipe off the stain to the color shade you desire. Remove any excess stain from the panel grooves with the foam brush provided; allow the stain to dry for at least 6 hours before applying topcoat. See **Therma-Tru® Same-Day® Stain Finishing Kit** instructions for complete details

THERMA-TRU®
DOORS

Constructor, subcontratista o proveedor:

Entregue estas instrucciones al propietario.

Los sistemas de puertas Therma-Tru® certificados y los sistemas de puertas Therma-Tru® que requieren aprobación (especialmente para aplicaciones en zonas costeras) posiblemente necesiten ensamblajes, componentes e instalaciones especiales. Siempre consulte los requisitos del sistema certificado y los dibujos de instrucción de ensamblaje e instalación para la aprobación de productos en nuestro sitio Web para dichas aplicaciones.

Los códigos de construcción pueden variar según la jurisdicción, el condado y/o el estado. Siempre verifique si es necesario algún ensamblaje o instalación especial según el código de su área.

Instrucciones de instalación para sistemas de puertas con vidrieras laterales con ventilación

Estas instrucciones de instalación están diseñadas para ayudar a los instaladores de puertas que comprenden algunos principios de carpintería y saben cómo usar herramientas eléctricas de manera adecuada y segura. El propósito de estas instrucciones es ilustrar la instalación de un sistema de puertas Therma-Tru® mediante el uso de métodos y materiales que ayudan a eliminar la infiltración de aire y las fugas de agua. Si se siguen cuidadosamente las instrucciones, el sistema de puertas tendrá una vida útil prolongada con una buena resistencia a los problemas relacionados con el aire y el agua.

Estos métodos han sido probados y son verdaderos. Son usados frecuentemente por constructores y remodeladores preocupados de manejar y mantener el agua fuera de las casas. En lugar de omitir cualquier paso que no comprenda, llame al 1-800-THERMATRU y solicite aclaraciones. Si todavía tiene dudas, busque ayuda profesional para la instalación.

Herramientas y materiales necesarios: Niveles de 2 y 6 pies, martillo, espátulas (rígidas y flexibles), escuadra de enmarcar, pistola para calafateo, escalera firme, calzas, cinta métrica, sellador elastomérico o de poliuretano de alta calidad, pistola atornilladora o taladro con broca para taladro de 1/8", navaja, puntas Philips #2 y #3, engrapadora, material aislante, lentes de protección, barrera resistente al agua, material tapajuntas, tornillos para exteriores #8 x 2-1/2" y revestimiento para alféizar opcional.

El módulo para puerta es grande, pesado y puede ser incómodo para levantar, mover y colocar. Use técnicas de levantamiento seguras y pida a un asistente que le ayude con la instalación para evitar lesiones personales y daños al módulo, y para facilitar una instalación correcta.

Lea todas las instrucciones antes de comenzar.

Mejores prácticas recomendadas por Therma-Tru®

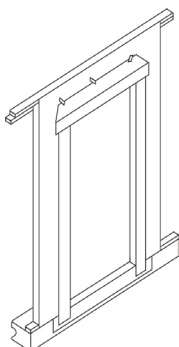

Use barreras resistentes al agua y tapajuntas flexibles:

Recomendamos el uso de barreras resistentes al agua (WRB, por sus siglas en inglés) aplicadas al revestimiento exterior (OSB u otras) y el uso de productos adhesivos o de tapajuntas flexibles para sellar el perímetro de la abertura. Se debe cortar la WRB en la abertura (siga las pautas del fabricante) con el cabezal de la lengüeta cubierta con cinta adhesiva, para sellarla después en el paso 13. Se debe aplicar el tapajuntas de manera superpuesta, como se muestra, siempre comenzando desde la parte inferior hacia la superior (siga las pautas del fabricante).

Use un revestimiento para alféizar: Recomendamos que primero compruebe que el revestimiento para alféizar cabe en la abertura siguiendo las instrucciones incluidas con éste. Coloque los extremos derecho e izquierdo del revestimiento para alféizar contra los lados de la abertura. Verifique que la sección central tenga el largo adecuado y, de ser necesario, córtela con una sierra de mano o tijeras para hojalata. Asegúrese de dejar 5,08 cm de superposición en las uniones.

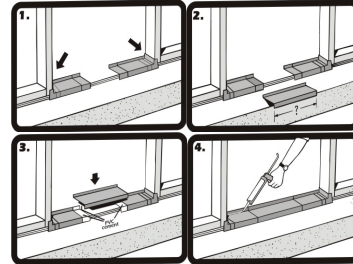

Nota: Use sólo el cemento PVC incluido en el kit de revestimiento para alféizar para unir las piezas. El revestimiento para alféizar se debe sellar al subsuelo usando un sellador elastomérico o de poliuretano, pero no aplique sellador a la parte inferior del alféizar cuando use un revestimiento para alféizar.

Paso 1: Revise el módulo para puerta.



Revise el ancho y alto.

Mida el tamaño del marco (ancho y alto), no de la moldura de ladrillo.

Retire las tablitras y el empaque, pero mantenga la puerta fijamente cerrada con el sujetador para transporte. No retire el sujetador para transporte hasta que se le indique hacerlo en el paso 9.

Paso 2: Revise y prepare la abertura.

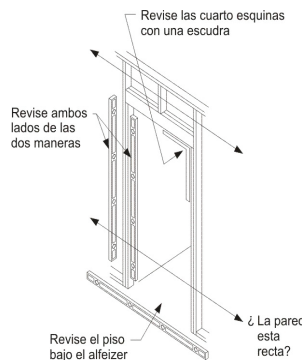

¿La abertura es del tamaño correcto para el módulo para puerta? Compárela con el tamaño del marco para puerta ahora, antes de la instalación. La abertura debe tener el alto del marco más 1,27 cm y el ancho del marco más 1,27 a 1,91 cm. **Resuelva cualquier problema en este momento.**

¿Los marcos y las paredes están A PLOMO? Use un nivel de 6 pies y revise ambos lados de la abertura, de dos maneras (del frente hacia atrás y de derecha a izquierda). **Resuelva cualquier problema en este momento.**

¿El subsuelo está nivelado y es sólido? **Proporcione una superficie plana, nivelada y limpia que soporte el peso, de manera que se pueda aplicar masilla de calafateo y sellar de forma adecuada el revestimiento para alféizar o el alféizar a la abertura. Raspe, lije o rellene según sea necesario.**

Nota: Si se necesita una separación adicional del cubrepiso, fije la tabla de calza al subsuelo. Asegúrese de calafatear bien bajo la tabla de calza.

¿La abertura está a escuadra? Revise todas las esquinas con una escuadra de enmarcar. Revise dos veces comparando las medidas diagonales. **Resuelva cualquier problema en este momento.**

Pre-Hung Venting Unit Installation

Paso 2, cont.: Revise y prepare la abertura.

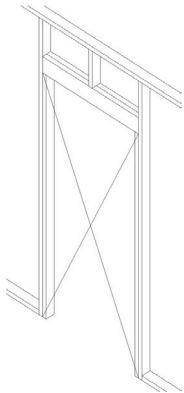

Asegúrese de que las paredes que enmarcan el perímetro de la abertura están en el mismo plano. Hágalo realizando una prueba con un cordel para verificar que están a plomo.

Prueba con cordel para verificar que están a plomo: Coloque un cordel que cruce diagonalmente la abertura desde el exterior, como se muestra. Los cordeles se deben tocar suavemente en el centro, de lo contrario, la abertura está "fuera de plomo" por el doble de dicha distancia y se debe corregir. Voltee el cordel sobre sí mismo para verificar ambos planos. **Resuelva cualquier problema en este momento.**

*El estado "fuera de plomo" es una de las razones más comunes por las que los módulos para puerta sufren fugas de aire y agua.

Paso 3: Aplique masilla de calafateo en el subsuelo.

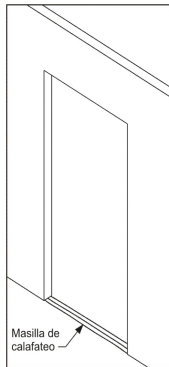

Coloque 3 cordones muy grandes de sellador en el subsuelo de la abertura. Extienda los cordones hasta alcanzar el ancho total de la abertura.

Use sólo sellador elastomérico o de poliuretano.

Use un tubo completo para calafatear a lo largo del subsuelo.

Paso 3A: Instalación con un revestimiento para alféizar.

Coloque los extremos derecho e izquierdo del revestimiento para alféizar sobre los cordones de masilla de calafateo y firmemente contra el lado de la abertura.

Luego, cubra generosamente las áreas superpuestas y empotradas de las piezas con el cemento PVC incluido. Coloque las secciones centrales en posición y mantenga las piezas juntas el tiempo suficiente para asegurar una buena adhesión.

Para una mayor protección, esparza un cordón de masilla de calafateo a lo largo de las uniones de adhesivo y, para ayudar a evitar la infiltración de aire, extienda un cordón de masilla de calafateo a lo largo del borde interior inferior del revestimiento para alféizar. Colocar masilla de calafateo adicional puede afectar el rendimiento del revestimiento para alféizar.

No calafatee la parte inferior del alféizar cuando use un revestimiento para alféizar

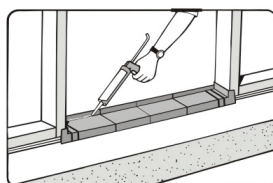
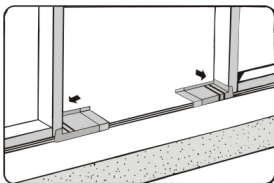

Paso 3B: Instalación sin un revestimiento para alféizar.

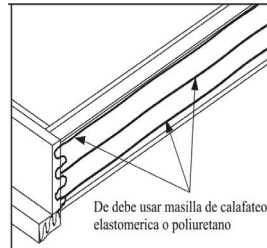

Coloque el módulo para puerta sobre su borde o frente, de manera que se pueda calafatear la superficie inferior del alféizar. Coloque cordones muy grandes de masilla de calafateo a lo largo de todo el ancho del alféizar. Además, coloque cordones de masilla de calafateo a lo largo de la unión del alféizar y la jamba y en la superficie inferior de las jambas y las molduras de ladrillo.

Nota: Si usa una extensión para alféizar, coloque un cordón grande de masilla de calafateo en la unión de la extensión y la entrada del alféizar.

Paso 3, cont.: Calafateo de la parte posterior de la moldura de ladrillo.

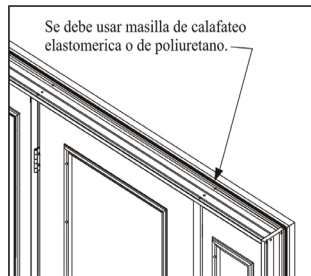

¡Importante!

Aplique sellador a la parte posterior de la moldura de ladrillo, en todo el perímetro del módulo para puerta. Es fundamental colocar un cordón de masilla de calafateo elastomérica o de poliuretano de 1,27 a 1,59 cm.

Paso 4: Coloque el módulo en la abertura y fije temporalmente.

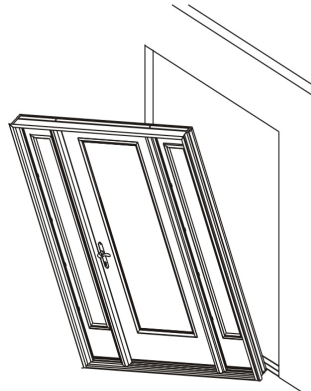

Levante el módulo. Incline el borde superior alejándolo de la abertura y centre el módulo; coloque el alféizar en el revestimiento para alféizar o sobre los cordones de masilla de calafateo e inclínelo hacia la abertura. Tenga presente la ubicación de las bisagras para todas las configuraciones de los módulos para puerta y márquelas en el frente de las jambas, cerca de las superficies de la puerta. Taladre previamente orificios de 0,32 cm de diámetro en dichas ubicaciones a través de la jamba del dintel adyacente a los entrepaños, sobre las vidrieras laterales activas. Puede ocultar las cabezas de los tornillos con una broca para avellanar.

Instale los tornillos en la ubicación del orificio central taladrado previamente en ambas jambas para asegurar el módulo temporalmente en el lugar. No apriete completamente los tornillos en este momento. Use tornillos para exteriores #8 X 2-1/2" ó 3".

No los apriete a través de la moldura de ladrillo.

Paso 5: Coloque a plomo y fije el listón vertical del cabezal lateral.

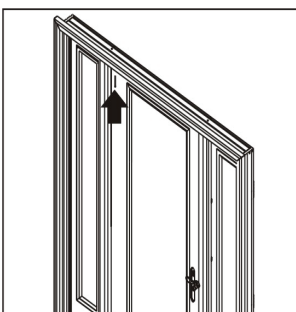

Use un nivel de 6 pies y coloque a plomo el entrepaño del lado con bisagras de dos maneras (de derecha a izquierda y del interior al exterior).

Coloque un tornillo en el orificio taladrado previamente en la jamba del cabezal, en el entrepaño del lado con bisagras.

No atomille el tornillo completamente en este momento

Paso 5, cont.: Coloque a plomo y fije el listón vertical del cabezal lateral.



Coloque calzas directamente en el listón vertical del lado con bisagras. Con un nivel de 6 pies, vuelva a revisar el listón vertical con bisagras para asegurarse de que está a plomo y recto. Termine de apretar el tornillo.

Nota: Cuando instale una puerta estilo francés con vidrieras laterales activas, primero coloque el entrepaño con bisagras para la puerta pasiva. Siga las instrucciones del paquete del astrágalo para obtener detalles sobre la configuración adecuada de la ubicación de los orificios para el perno deslizante.

Paso 6: Ajuste y fije el listón vertical del lado de la cerradura.

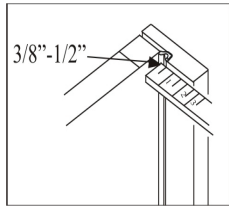

Ajuste el listón vertical del lado de la cerradura de manera que los burletes hagan contacto con la superficie de la puerta de forma pareja en la parte superior, la parte del medio y la parte inferior a unos 0,95 a 1,27 cm cuando la puerta esté completamente cerrada. Coloque un tornillo en el orificio taladrado previamente en la jamba del cabezal, en el entrepaño del lado de la cerradura.

No apriete completamente el tornillo en este momento.



Coloque calzas directamente en el listón vertical del lado de la cerradura. Vuelva a revisar el listón vertical del lado de la cerradura para asegurarse de que los burletes estén en contacto de forma pareja desde la parte superior a la parte inferior. Termine de apretar el tornillo.

Paso 7: Ajuste y asegure las jambas laterales.

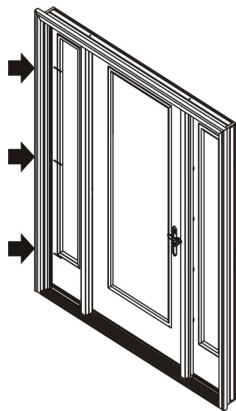

Ajuste la jamba de la bisagra de la vidriera lateral en el lado del listón con bisagras del módulo para que los burletes hagan contacto de forma pareja desde la parte superior a la parte inferior del lado de la cerradura de la vidriera lateral. Pase un tornillo a través de la jamba del lado con bisagras hasta el montante, en cada ubicación de las bisagras restantes.

No apriete completamente los tornillos en este momento.

Coloque calzas sobre los tornillos detrás de cada ubicación de las bisagras entre la abertura y la jamba, y realice ajustes de manera que el margen entre la vidriera lateral y el listón queden parejos desde la parte superior a la parte inferior. Este margen debe ser ligeramente más grande que el margen de la puerta. Vuelva a revisar la jamba de las bisagras de la vidriera lateral para asegurarse de que los burletes hagan contacto de manera pareja desde la parte superior a la parte inferior. Termine de apretar los tornillos.

Repita el paso anterior en la jamba de las bisagras de la vidriera lateral en el listón del lado de la cerradura del módulo.

Paso 8: (Puerta estilo francés) Calza temporal en la jamba del cabezal.

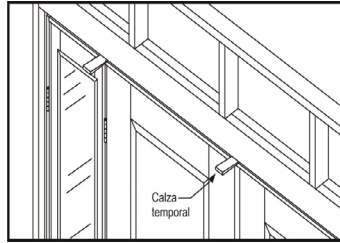

Cuando instale una puerta estilo francés con vidrieras laterales activas, coloque calzas temporales sobre el centro del marco del cabezal donde se unen las puertas. Taladre previamente e inserte un tornillo a través del marco en el dintel y luego retire las calzas temporales.

Paso 9: Retire el sujetador para transporte y abra la puerta.

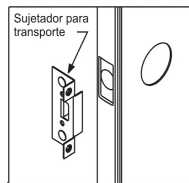

Retire los sujetadores para transporte. Verifique que la puerta y las vidrieras laterales funcionen correctamente.

Haga los ajustes necesarios.

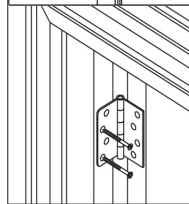

Con las vidrieras laterales abiertas, taladre orificios guía de 0,32 cm de diámetro e instale los tornillos para bisagra largos en las ubicaciones de las bisagras más cercanas al burlete. Realice el mismo procedimiento con todas las bisagras.

Paso 10: Ajuste el alféizar.

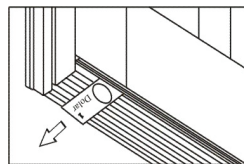

Su módulo para puerta tiene cubiertas para umbral ajustables. Cuando se ajustan correctamente, deben quedar apretadas y debe ser ligeramente difícil jalar un billete de un dólar por debajo de la puerta y las vidrieras laterales cuando están bien cerradas. Se debe poder retirar el billete de un dólar sin rasgarlo.

Esta verificación se debe realizar en todas las ubicaciones de tornillos ajustables de cada cubierta para umbral activo.

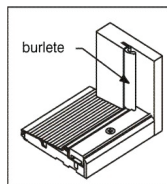

Después de ajustar la cubierta para umbral, asegúrese de que el burlete está al ras con la parte superior de la cubierta para umbral. Corte si es necesario.

Paso 11: Instale las almohadillas de sellado para esquinas: Sólo para módulos de abertura hacia adentro.

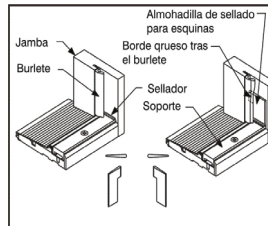

Aplique el sellador (elastomérico o de poliuretano) en la unión donde la cubierta para umbral se une con las jambas y los listones verticales.

Retire el papel autoadhesivo de las almohadillas de sellado para esquinas y aplíquelas en la jamba o en el listón vertical, alineando de forma pareja la parte inferior con la parte superior de la cubierta para umbral. Cuando la almohadilla se instala correctamente, la lengüeta se encontrará en la parte superior y la parte estrecha en la inferior.

La parte inferior de la almohadilla tiene el mismo ancho que la cubierta para umbral para facilitar la alineación durante la instalación. Las almohadillas de las esquinas se deben instalar en ambos lados de cada abertura activa.

Pre-Hung Venting Unit Installation

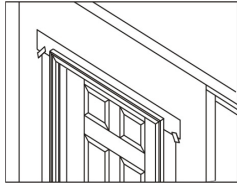
Paso 12: Impermeabilice, aplique un acabado y dé mantenimiento.

Proporcione y mantenga una cubierta de goteo o un tapajuntas de dintel instalados de forma adecuada para proteger la parte superior de las superficies del ingreso de agua y del daño. Coloque cinta adhesiva y selle de manera adecuada la parte superior de la lengüeta de la barrera resistente al agua (WRB) sobre el tapajuntas del dintel.

Calafatee alrededor de todo el lado expuesto al clima del módulo, sellando a lo largo de la moldura de ladrillo hasta el material de tapajuntas o los paneles de revestimiento y selle todas las uniones entre las jambas y las molduras.

Selle las uniones entre el reborde de los aditamentos exteriores y el frente de la puerta para evitar la infiltración de aire y agua.

Coloque y ajuste clavos galvanizados para acabado a través de la moldura de ladrillo, alrededor del perímetro. Use tornillos para exteriores si va a instalar una contrapuerta en la moldura de ladrillo. Avellane todos los sujetadores y cúbralos con masilla para exteriores.

Añada material aislante a la cavidad entre la abertura y el módulo, a fin de reducir la infiltración de aire y la transferencia de calor.

Se debe dar acabado a todas las puertas Therma-Tru® de fibra de vidrio dentro de 6 meses a partir de la instalación para una adecuada cobertura de la garantía.

Pinte o tiña de acuerdo con las instrucciones de acabado de Therma-Tru®. No pinte ni tiña el burlete, está ajustado para la fricción y se retira fácilmente para pintar o teñir.

Se debe dar acabado a los 6 lados de las puertas. Se deben inspeccionar y dar mantenimiento a todos los bordes de las puertas con la misma regularidad que a todas las demás superficies.

Se debe aplicar pintura base, pintura o tintes (una capa más una capa superior), a todas las superficies de madera desnudas, como el marco para puerta expuesto al clima, dentro de dos semanas a partir de la exposición para lograr un mejor rendimiento.

Dé mantenimiento o reemplace los selladores y acabados tan pronto cualquier deterioro sea evidente. En el caso de la pintura brillante o semibrillante y de las capas transparentes, hágalo cuando la superficie se vuelva opaca o áspera. Los climas y las exposiciones más rigurosos necesitarán un mantenimiento más frecuente.

Visite nuestro sitio Web www.thermatru.com para imprimir instrucciones de instalación además de las instrucciones para el acabado de teñido Same-Day®. También podrá ver nuestro video de solución de problemas para resolver problemas menores en la instalación y para realizar ajustes.

Instrucciones para el acabado:

Trabaje sólo cuando las temperaturas se encuentren entre 10 y 32,2°C y la humedad sea menor a un 85%. No aplique acabados bajo la luz solar directa. Trabaje sólo en áreas bien ventiladas.

Módulos para puerta Smooth-Star®:

Para pintar puertas: Primero limpie con un detergente suave y agua o use una solución de TSP (fosfato trisódico). Enjuague bien y deje secar completamente. Proteja los aditamentos, los vidrios y los burletes antes de pintar. Use pintura de látex acrílico de alta calidad para casas y siga las instrucciones del fabricante para su aplicación. Use acabados para exteriores para las superficies exteriores. Pinte los bordes y los extremos expuestos de la puerta.

Para pintar marcos de vidrieras para puertas: Primero retire cualquier exceso de sellador de vidrios rociando con un limpiador de ventanas o agua. Use una navaja de un solo filo para desprender el sellador a lo largo del borde del marco. Raspe el sellador del vidrio sosteniendo la cuchilla de la navaja en un ángulo de 45 grados. Retire el residuo restante con un limpiador de ventanas o aguarrás mineral. Limpie el marco del vidrio con un detergente suave y agua o use una solución de TSP. Enjuague bien y deje secar completamente. Proteja el vidrio. Aplique una pintura base de resina alquídica o acrílica en los marcos de los vidrios. Deje secar la pintura base antes de aplicar las capas de pintura de acabado. Use pintura de látex acrílico para casas de alta calidad y siga las instrucciones del fabricante para su aplicación. Use acabados para exteriores para las superficies exteriores.

Puertas Fiber-Classic®:
Para dar acabado a marcos de vidrieras para puertas y a accesorios para paneles:

Primero retire cualquier exceso de sellador de vidrios rociando con un limpiador de ventanas o agua. Use una navaja de un solo filo para desprender el sellador a lo largo del borde del marco. Raspe el sellador del vidrio sosteniendo la cuchilla de la navaja en un ángulo de 45°. Retire el residuo restante con un limpiador de ventanas o aguarrás mineral. Limpie el marco del vidrio con un detergente suave y agua o use una solución de TSP. Enjuague bien y deje secar completamente. Proteja el vidrio. Aplique una pintura base de resina alquídica o acrílica en los marcos de los vidrios. Deje secar la pintura base antes de aplicar las capas de pintura de acabado. Use pintura de látex acrílico de alta calidad para casas y siga las instrucciones del fabricante para su aplicación y tiempo de secado. Use acabados para exteriores para las superficies exteriores.

Para pintar puertas:

Primero limpie con un detergente suave y agua o use una solución de TSP (fosfato trisódico). Enjuague bien y deje secar completamente. Aplique una pintura base de resina alquídica o acrílica. Deje que la pintura base se seque completamente, luego, pinte con pintura látex de casas siguiendo las instrucciones del fabricante para su aplicación. Use una pintura base y una pintura que sean compatibles. Use acabados para exteriores para las superficies exteriores. Pinte los bordes y los extremos expuestos de la puerta.

Para teñir puertas:

Primero limpie con un paño limpio y aguarrás mineral y deje secar al aire o lave la puerta con un detergente suave y agua o una solución de TSP (fosfato trisódico). Enjuague bien y deje secar completamente. En el caso de las superficies teñidas, sólo recomendamos el uso de tintes y productos de capas transparentes que se encuentran en el kit para acabado Therma-Tru® Same-Day® Stain. Aplique el tinte con un paño. Mientras más tiempo se deje el tinte para "asentarse" antes de limpiarlo, más oscuro será el color. Use un paño limpio para limpiar el tinte hasta lograr el tono que desea. Retire cualquier exceso de tinte de las grietas del panel con la brocha de espuma que se incluye. Deje secar el tinte durante al menos 6 horas antes de aplicar una capa superior. Consulte las instrucciones del kit para acabado Therma-Tru® Same-Day® Stain para obtener información detallada.

Pre-hung Rustic Arch/Radius Installation Instructions

1 CHECK AND PREPARE OPENING

- Is subfloor level and solid? Provide a flat, level clean bearing surface so the sill may be caulked and sealed to the opening. Scrape, sand, or fill as required.
- Shim subfloor for floor covering clearance if required. If shimming, caulk under shims.
- Is opening square? Check all corners with a framing square. Double-check by comparing diagonal measurements. Fix any problems now.
- Are framing and walls plumb? Use a 6-foot level and check both sides of opening, both ways. Fix any problems now.
- Are the wall surfaces around the opening on the same plane? There must be no “warps” or “jogs”. Fix any problems now.
- Is opening correct size? Check it against door frame size now before installation. Opening should be frame height plus 1/2” and frame width plus 1/2” to 1”.

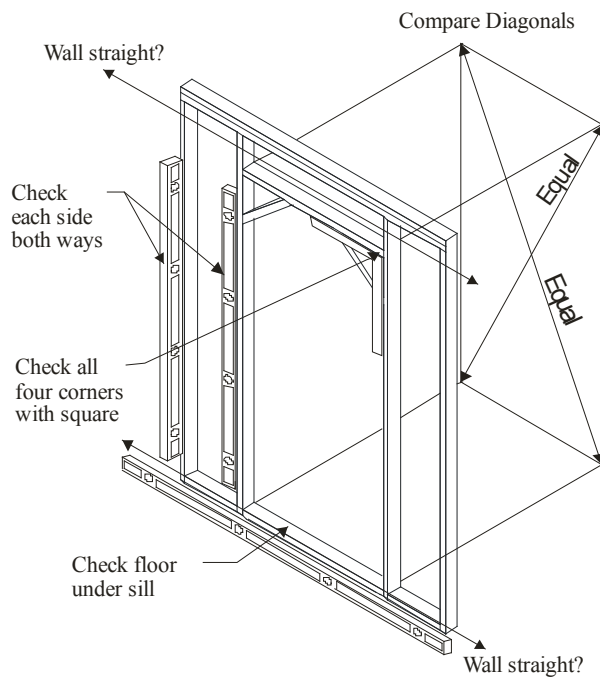

2 SUPPORT FRAME CONSTRUCTION

Build support framing at top for radius/arched top head jamb as shown below

Radius Top Head Jamb

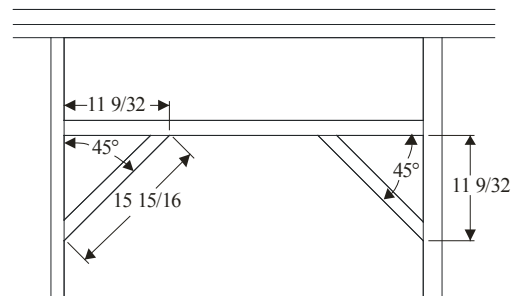

Arch Top Head Jamb

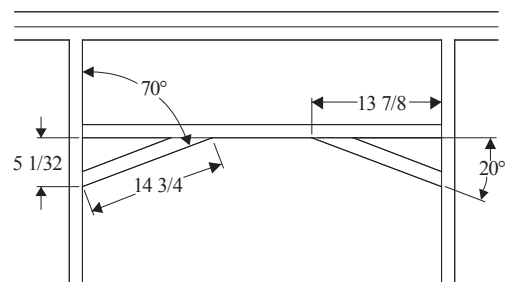

Refer to MSDRIST for all other Pre-Hanging Instructions

Pre-hung Rustic Arch/Radius Installation Instructions

3 SHIM BEHIND JAMBS, THEN ADJUST THE REST OF THE FRAME

- Go through another opening to work on swing side of door
- Leave door fastened closed with transport clip
- Shim at the indicated areas in the figure; Shim behind each hinge, shim at the angled framing members at the top, and shim side areas as shown
- Recheck hinge jamb with a 6-foot level to ensure it is plumb and straight
- Adjust frame so the frame face is flush with door face all around
- Secure hinge jamb from the other side of the door. Set nails or finish driving screws directly below shims
- Due to varying dimensions of mouldings, there may be a gap at the miter of the brick moulding where the radius/arch piece of the head meets the straight leg of the side. This is expected and should be caulked prior to painting.

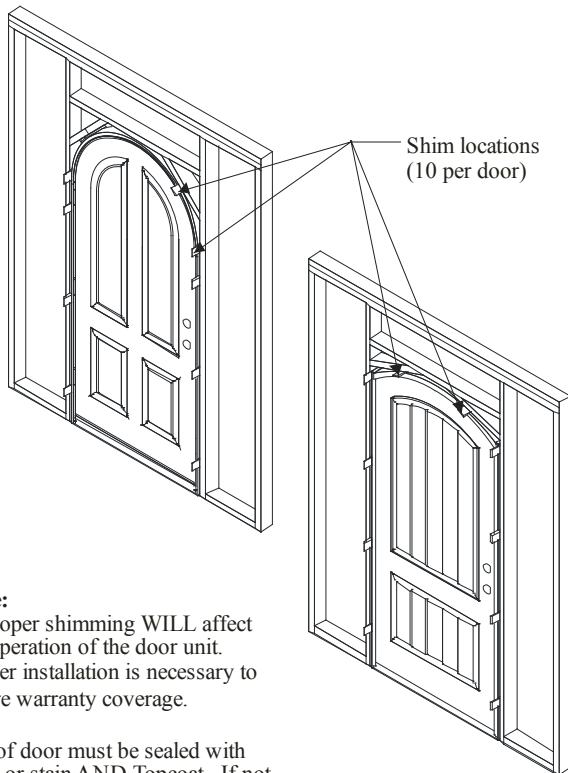

Note:
Improper shimming WILL affect the operation of the door unit. Proper installation is necessary to insure warranty coverage.

Top of door must be sealed with paint or stain AND Topcoat. If not finished the door warranty is VOID!

4 SCREW INSTALLATION

Special Instructions For Radius Top Head Jambs:

- Use #10 x 2" wood screws
- Install screws in the order shown below.
- Shims are required at all screw locations to control the final shape of the radius and to allow for the correct margins around the door.

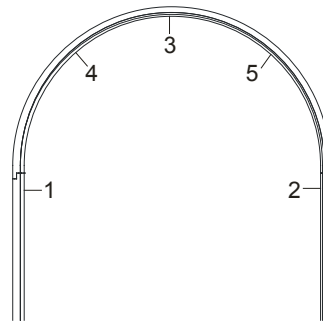

For Both Radius Top Head Jambs:

- Use #10 x 2" wood screws
- Position all screws in the location shown below. The screws must be positioned such that the weather-strip hides the screw heads.

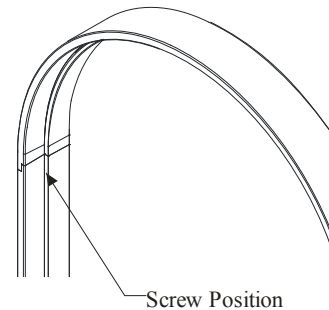

Warning :
Modification or machining of this product can release wood dust, a substance know to the State of California to cause cancer.

Refer to MSDRIST for all other Pre-Hanging Instructions

Part#: MSDRARRADIST65 REV. B

© Copyright 2011 Therma-Tru Corporation.

Therma-Tru Doors is an operating company of Fortune Brands, Inc. 3/20

Swing Door Handle Set Installation Instructions

A Phillips screwdriver is required.

A Hex wrench for set screws is provided in the hardware package

To prevent damage to the handle set while in the construction phase, use the enclosed construction handle to operate the door. Lift to engage multipoint to close door. Push down to open the door.

Use water to clean. Do not use brass cleaner as it will remove the protective coating. Brass Strike Plates are Solid Brass and can be polished as needed.

Note: Handles and backplates vary by style but application is the same.

1. Apply the backplate gasket to the inside of the exterior backplate. Push gaskets firmly into place to ensure a tight seal. Attach interior and exterior backplates to the door and fasten loosely with the screws provided. Note: The screw heads must be on the interior side of the door.
2. Mount nylon bushings to door gear handle hole on interior and exterior backplates.
3. Insert the two piece handle shaft into one handle. Be sure to orient the shaft as shown below. Screw the set screw until flush with handle using the allen wrench provided. Insert the handle with the shaft through the backplate and door gear handle hole until extending out opposite side of door.
4. Install remaining handle onto shaft, pressing tightly to the backplates. Tighten the handle set screw with the allen wrench. Screw until flush with handle.
5. Attach thumbturn to cylinder.
6. Insert the keyed cylinder from the interior side of the door until it is flush with the exterior backplate. Install the cylinder screw in the screw hole below the deadbolt in the edge of the door. If passive deadbolt will not turn, it is installed incorrectly. See Installation Instructions for active & passive 90-Degree Cylinder.
7. Tighten the backplate screws.

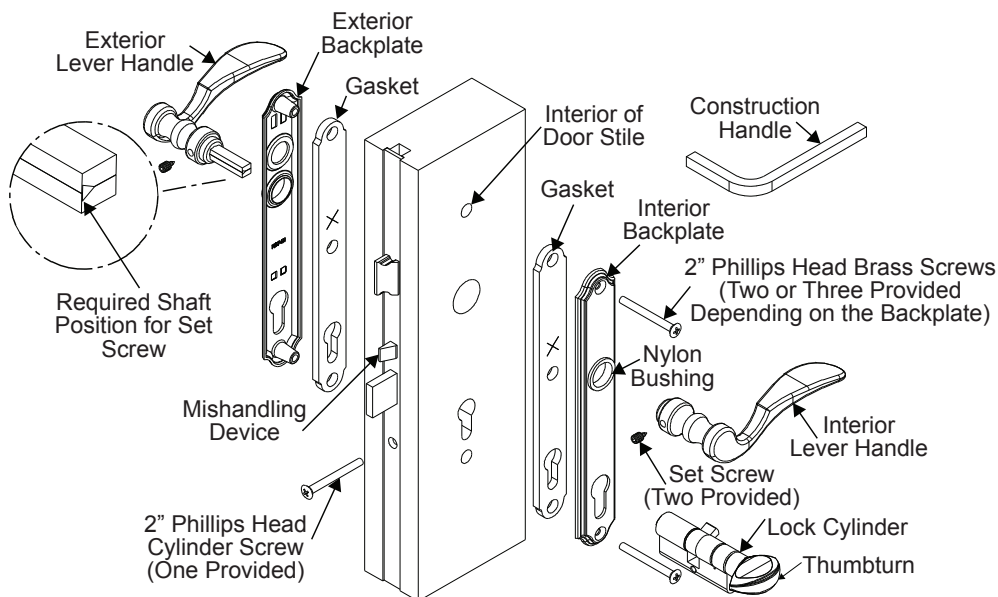

Multi-Point Lock

Quick Tip Sheet & Instructions

Swing Door Handle Operation Instructions

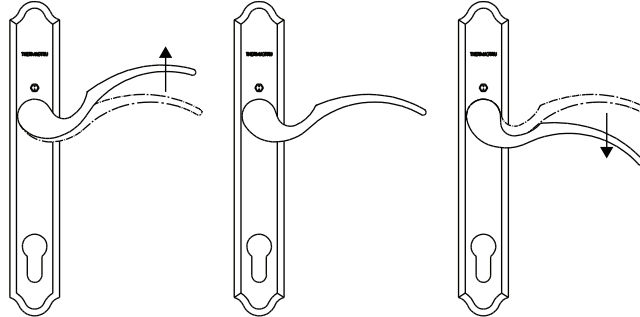

To lock system.
Lift handle to engage
multipoints prior to
engaging deadbolt.

Handle will
automatically
return to center
position.

To open door, disengage
deadbolt with key or
thumbturn, push handle
down to stop and
then open door.

Use key or thumbturn to
engage deadbolt.

TROUBLESHOOTING GUIDE

Note: To lock door, shootbolts, locking point tongues and deadbolt must all fully extend. Be certain door is square in frame before adjusting other hardware. With the door in the open position, engage system by lifting handle and letting handle return to its center position. Extend deadbolt by turning thumb turn. If the tongues or shootbolts extend and the deadbolt operates, the handle system is fully functional.

1. SYSTEM WILL NOT OPERATE WHEN YOU LIFT THE HANDLE

Probable Cause: Improper installation of handle set.

Solution: Remove handle and reinstall.
See Handle Set Installation Instructions.

2. SYSTEM OPERATES IN THE OPEN POSITION WHEN YOU LIFT HANDLE BUT NOT IN THE CLOSED POSITION WITH THE DOOR SHUT

Probable Cause: Relationship of door in the frame.

Solution: Check to make sure door is square in the frame.

3. LOCKING POINTS DO NOT EXTEND

Probable Cause: Deadbolt is not fully extending.

Solution: Clear away anything blocking travel of deadbolt (insulation, wood, etc.).

4. DEADBOLT WILL NOT FULLY ENGAGE

Probable Cause: Locking points are not fully engaged. System design does not permit deadbolt operation unless locking points are fully engaged.

Solution: Check system for binding problems. Confirm deadbolt extends fully into strike. Check to confirm locking points are correctly engaging strikes on the frame.

5. THUMBTURN OR KEY WILL NOT TURN

Probable Cause: Backplates may not be on straight

Solution: Confirm that inside and outside holes line up with lockcase. Loosen backplate screws 1/2 turn.

6. SET SCREWS WILL NOT GO INTO HANDLE COMPLETELY

Probable Cause: Shaft is not assembled properly.

Solution: Remove handle to see how shaft is assembled. See Handle Set Installation Instructions for proper assembly and position of shaft.

7. BOTTOM LOCKING POINT MOVES BUT TOP LOCKING POINT DOES NOT

Probable Cause: Top extension drive rail is not connected to the lock gear.

Solution: Remove screws used to attach top extension to the door and the machine screw that attaches it to the lock gear, and remove top extension. Place the end of the drive rail (the "L" shape in the lockcase above the latchbolt, as you slide the top extension into the door. Fasten with a screw at the lockcase and one up higher. Operate the gear to make sure it works. Finish installing the remainder of the screws.

8. KEY DOES NOT WORK IN CYLINDER

Probable Cause: Cylinder was rekeyed incorrectly.

Solution: Check with Builder or Installer to see if cylinder was rekeyed to match other doors in the house. If so, return to locksmith to rekey properly.

**INSTALLATION INSTRUCTIONS FOR
ACTIVE AND PASSIVE 90-DEGREE CYLINDERS**

1. The drive tab (A) must be aligned with the cylinder (B) to install the cylinder into the lock mechanism. If the tab cannot be rotated to this position, push the pin (C) down with the ring wrench (D) by inserting into the top of the slot (C), pushing inward and then pulling downward to disengage the stops. Turn the knob (E) until the drive tab (A) is aligned with the cylinder (B).
2. Holding in this position, insert the cylinder body into door so the tab (A) on the cylinder is inside of the lock.
3. Rotate the knob (E) towards the edge of the door so that the tab (A) moves inward toward the door center, the tab (A) will seat properly and allow the deadbolt to extend. On the passive door, if the knob is rotated in the wrong direction, it will rotate approximately 120 degrees and lock up the system. If this happens, push the pin (C) down with the ring wrench (D) to disengage the stops and turn the knob (E) in the opposite direction until the deadbolt extends.
4. NOTE: The passive door cylinder is shorter, has no key on the outside and no deadbolt to extend. If it is properly locked, the handles do not operate.
5. Install cylinder screw into hole in edge of door.
6. If the set screw (F) is at the top of the knob, remove the set screw, reverse the knob 180 degrees and reinstall so the set screw is at the bottom of the knob.
7. To remove cylinder, loosen and remove cylinder screw and repeat step 1 and slide cylinder from door.

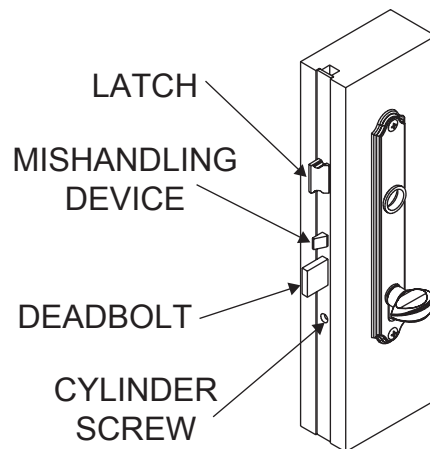
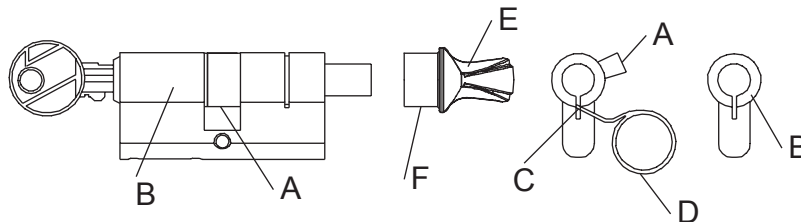

1994-2009 Therma-Tru Corp. All rights reserved. Therma-Tru is an operating company of Fortune Brands, Inc.

Multi-Point Lock

Quick Tip Sheet & Instructions

THERMA TRU
DOORS

HARDWARE MODIFICATION INSTRUCTION SHEET

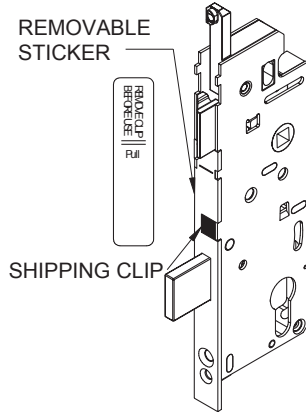

SHIPPING CLIP FOR MISHANDLING DEVICE

1. Remove sticker.
2. Remove shipping clip.
3. Make sure mishandling device is sloped to engage strike plate.
4. If not, pull out and spin 180 degrees.

REVERSING LATCH IS LATCH IS BACKWARDS.

1. Pull out latch until latch clears lockcase.
2. Rotate latch 180 degrees and release back into lockcase.

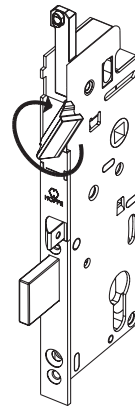

CAUTION:

Do not remove torx screws under any circumstances. They are not a field serviceable item.

SOCKET STRIKE INSTALLATION

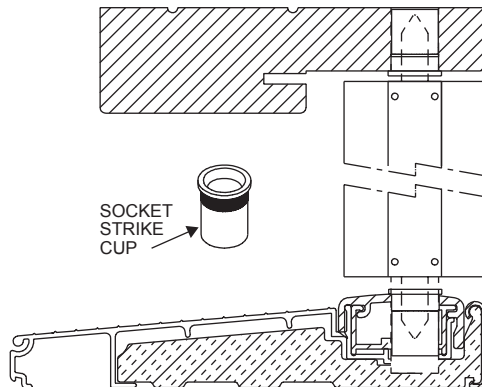

1. Mark hole location using tip of shootbolts as guides.
2. Drill 9/16" hole at marks through jamb and sill.
3. Insert Socket Strike Cup into 9/16" holes at head jamb and sill.

NOTE: Door WILL NOT lock unless bolts are fully extended.

June 2009 Part# BMTTmplQT

Instrucciones para el juego de manijas de puerta batiente

Necesita un destornillador Phillips

En el paquete de accesorios se suministra una llave hexagonal para tornillos de fijación.

Para evitar el daño al juego de manijas durante la fase de construcción, utilice la manija de construcción que se suministra para hacer funcionar la puerta. Levante para enganchar la cerradura multipunto para cerrar la puerta. Presione hacia abajo para abrir la puerta.

Utilice agua para limpiar. No utilice limpiador de latón porque retirará el revestimiento protector. Las placas de la cerradura son de latón sólido y pueden pulirse según sea necesario.

Nota: Las manijas y las placas posteriores pueden variar de estilo pero la aplicación es la misma.

1. Aplique la guarnición de la placa posterior a la parte interior de la placa posterior externa. Presione las guarniciones firmemente en su lugar para lograr un ajuste adecuado. Fije las placas posteriores internas y externas a la puerta y ajuste sin apretar con los tornillos que se suministran. Nota: Las cabezas de los tornillos deberán estar en el lado interno de la puerta.

2. Monte los cojinetes de nailon en el agujero del mecanismo de la manija de la puerta en las placas posteriores internas y externas.

3. Inserte el eje de la manija de dos piezas en una manija. Cerciórese de orientar el eje como se ilustra. Atornille el tornillo de fijación hasta que quede a ras con la manija utilizando la llave Allen que se suministra. Inserte la manija con el eje a través de la placa posterior y del agujero del mecanismo de la manija de la puerta hasta que salga por el lado opuesto de la puerta.

4. Instale la manija restante en el eje, presionando firmemente en las placas posteriores. Apriete el tornillo de fijación de la manija con la llave Allen. Atornille hasta que quede a ras con la manija.

5. Fije el cerrojo manual al cilindro.

6. Inserte el cilindro programado desde el lado interior de la puerta hasta que quede a ras con la placa posterior externa. Coloque el tornillo del cilindro en el agujero del tornillo debajo de la cerradura de doble seguridad en el borde de la puerta. Si la cerradura de doble seguridad pasiva no gira, está instalada incorrectamente. Refiérase a las instrucciones de instalación para cilindros activos y pasivos de 90 grados.

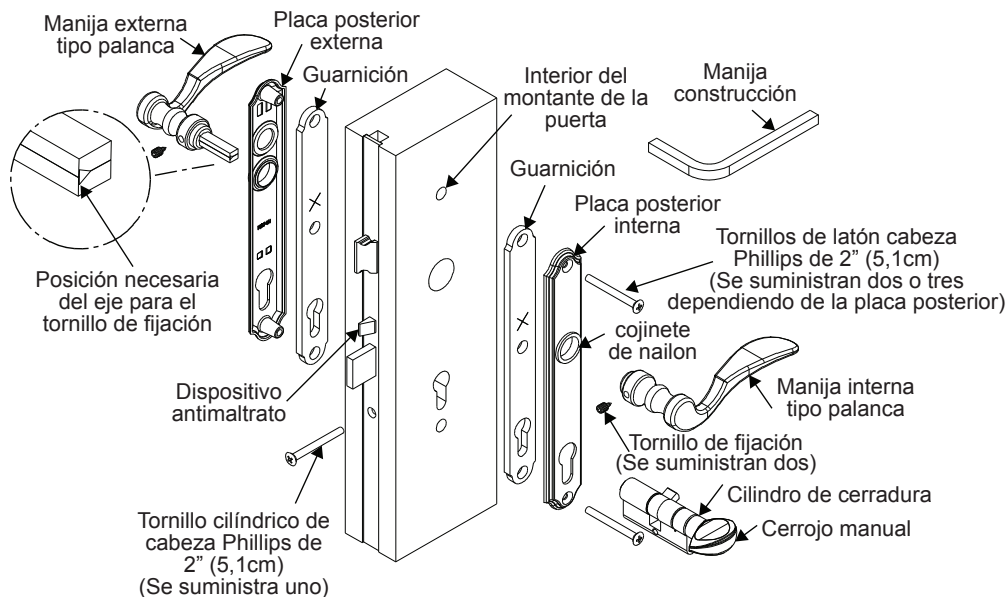

Multi-Point Lock

Quick Tip Sheet & Instructions

THERMA TRU
DOORS

Instrucciones de funcionamiento para la manija de puerta batiente

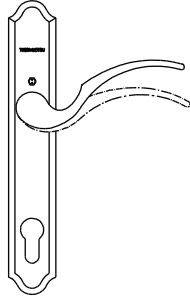

Para trancar el sistema. Levante la manija para enganchar los multipuntos antes de enganchar la cerradura de doble seguridad.

Utilice la llave o el cerrojo manual para enganchar la cerradura de doble seguridad.

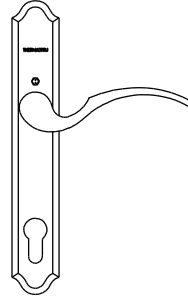

La manija regresará automáticamente a la posición central.

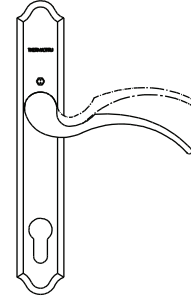

Para abrir la puerta, desenganche la cerradura de doble seguridad con la llave o el cerrojo manual, empuje la manija hacia abajo para parar y luego abra la puerta.

HOJA DE INSTRUCCIONES DE MODIFICACIÓN DE LOS ACCESORIOS METÁLICOS

ETIQUETA ENGOMADA DESPRENDIBLE

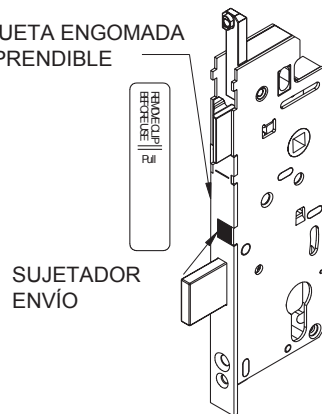

SUJETADOR ENVÍO

SUJETADOR DE ENVÍO PARA DISPOSITIVO ANTIMALTRATO

1. Retire la etiqueta engomada.
2. Retire el sujetador de envío.
3. Compruebe que el dispositivo antimaltrato esté inclinado para que enganche en la placa de la cerradura.
4. Si no, saque y gire 180 grados.

CÓMO INVERTIR EL PICAPORTE SI ESTÁ HACIA ATRÁS

1. Hale el picaporte hasta que salga de la caja de la cerradura.
2. Rote el picaporte 180 grados y deje que regrese a la caja la cerradura.

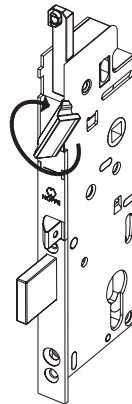

**INSTRUCCIONES DE INSTALACIÓN PARA
CILINDROS ACTIVOS Y PASIVOS DE 90 GRADOS**

1. La lengüeta impulsora (A) deberá estar alineada con el cilindro (B) para instalar el cilindro en el mecanismo de tranca. Si la lengüeta no puede rotarse a esta posición, presione la clavija (C) hacia abajo con la llave de aro (D) insertando en la parte superior de la ranura (C), presionando hacia adentro y luego halando hacia abajo para desenganchar los topes. Gire la perilla (E) hasta que la lengüeta impulsora (A) esté alineada con el cilindro (B).
2. Sosteniéndola en esta posición inserte el cuerpo del cilindro en la puerta de modo que la lengüeta (A) del cilindro esté dentro de la cerradura.
3. Gire la perilla (E) hacia el borde de la puerta de modo que la lengüeta (A) se mueva hacia dentro hacia el centro de la puerta, la lengüeta (A) se asentará adecuadamente y permitirá que la cerradura de doble seguridad se extienda. En la puerta pasiva, si la perilla se ha rotado en la dirección incorrecta, rotará aproximadamente 120 grados y trancará el sistema. Si esto ocurre, presione el pasador (C) hacia abajo con la llave de aro (D) para desenganchar los topes y gire la perilla (E) en la dirección opuesta hasta que la cerradura de seguridad se extienda.
4. NOTA: El cilindro de la puerta pasiva es más corto, no tiene llave en la parte externa y no tiene cerradura de seguridad que se extienda. Si está adecuadamente cerrada, las manijas no funcionan.
5. Coloque el tornillo del cilindro en el agujero en el borde de la puerta.
6. Si el tornillo de fijación (F) está en la parte superior de la perilla, retire el tornillo de fijación, reverse la perilla 180 grados y vuelva a instalar de modo que el tornillo de fijación esté en la parte inferior de la perilla.
7. Para retirar el cilindro, afloje y retire el tornillo del cilindro, repita el paso 1 y saque el

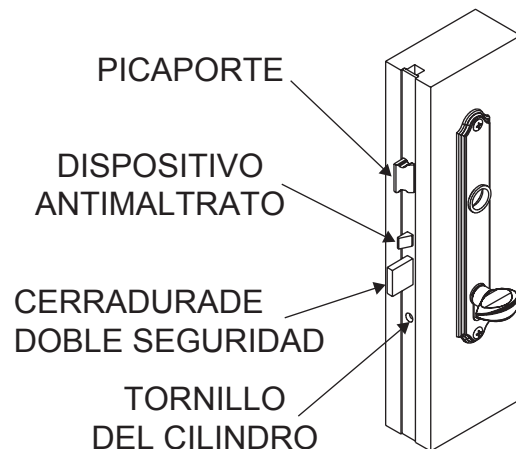
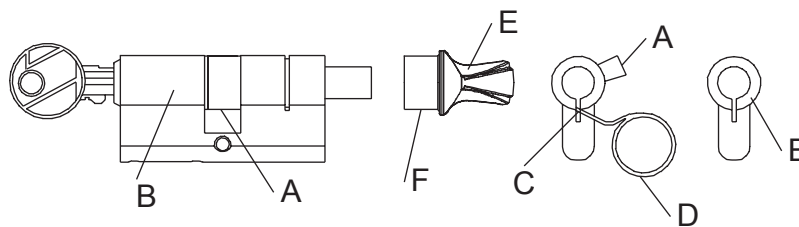

1994-2009 Therma-Tru Corp. Todos los derechos reservados. Therma-Tru Doors es una operación de Fortune Brands, Inc.

Multi-Point Lock

Quick Tip Sheet & Instructions

THERMA TRU
DOORS

GUÍA PARA LA LOCALIZACIÓN Y SOLUCIÓN DE PROBLEMAS

Nota: Para trancar la puerta, los pernos deslizantes, las lengüetas con punto de tranca y la cerradura de doble seguridad deberán estar totalmente extendidos. Cerciérese de que la puerta esté a escuadra con el marco antes de ajustar los accesorios metálicos. Con la puerta en la posición abierta, enganche el sistema levantando la manija y dejando que regrese a su posición central. Extienda la cerradura de doble seguridad girando el cerrojo manual. Si las lengüetas o los pernos deslizantes se extienden y la cerradura de doble seguridad funciona, el sistema de manijas está totalmente funcional.

1. EL SISTEMA NO FUNCIONA CUANDO LEVANTA LA MANIJA

Causa probable: Instalación inadecuada del juego de manijas.

Solución: Retire la manija y vuelva a instalar. Refiérase a las instrucciones de instalación del juego de manijas.

2. EL SISTEMA FUNCIONA EN LA POSICIÓN ABIERTA CUANDO LEVANTA LA MANIJA PERO NO EN LA POSICIÓN CERRADA CON LA PUERTA TRANCADA

Causa probable: La relación de la puerta con el marco.

Solución: Verifique para comprobar que la puerta esté a escuadra con el marco.

3. LOS PUNTOS DE TRANCA NO SE EXTIENDEN

Causa probable: la cerradura de doble seguridad no se extiende totalmente.

Solución: Despeje cualquier obstáculo que esté en el camino de la cerradura de doble seguridad (aislante, madera, etc.).

4. LA CERRADURA DE DOBLE SEGURIDAD NO ENGANCHAN COMPLETAMENTE

Causa probable: Los puntos de tranca no están completamente enganchados. El diseño del sistema no permite el funcionamiento de la cerradura de doble seguridad a menos que los puntos de tranca estén completamente enganchados.

Solución: Revise el sistema en busca de problemas de desplazamiento. Confirme que la cerradura de doble seguridad se inserta completamente en la hembra de la cerradura. Revise para confirmar si los puntos de tranca están enganchando correctamente en el marco.

5. EL CERROJO MANUAL O LA LLAVE NO GIRAN

Causa probable: Las placas posteriores puede que no estén derechas

Solución: Confirme que los agujeros internos y externos estén alineados con la caja de la cerradura. Afloje ½ vuelta los tornillos de la placa posterior.

6. LOS TORNILLOS DE FIJACIÓN NO PENETRAN EN LA MANIJA COMPLETAMENTE

Causa probable: El eje no está ensamblado adecuadamente.

Solución: Retire la manija para ver como está ensamblado el eje. Refiérase a las instrucciones de instalación del juego de manijas para el ensamblaje adecuado y la posición del eje.

7. EL PUNTO DE TRANCA INFERIOR SE MUEVE PERO EL PUNTO SUPERIOR DE TRANCA NO

Causa probable: La barra impulsora de extensión superior no está conectada al mecanismo de la cerradura.

Solución: Retire los tornillos utilizados para fijar la extensión superior a la puerta y el tornillo para metáls que la fija al mecanismo de la cerradura, y retire la extensión superior. Coloque el extremo de la barra impulsora (la forma "L" de la caja de la cerradura sobre el picaporte de resbalón, a medida que desliza la extensión superior en la puerta. Asegure con un tornillo en la caja de la cerradura y otro más alto. Haga funcionar el mecanismo para confirmar que trabaja bien. Termine de colocar el resto de los tornillos.

8. LA LLAVE NO FUNCIONA EN EL CILINDRO

Causa probable: El cilindro fue reprogramado incorrectamente.

Solución: Revise con un constructor o instalador para comprobar si el cilindro fue reprogramado igual que las otras puertas de la casa. Si es así, regrese a la cerrajería para que se lo reprogramen adecuadamente.

INSTALACIÓN DE LA HEMBRA DEL CASQUILLO

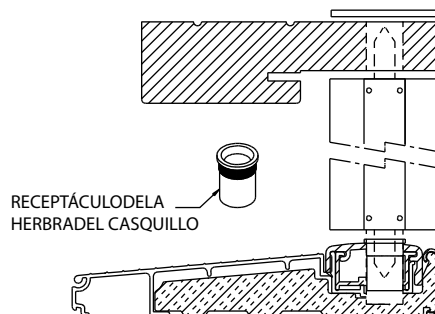

1. Marque la ubicación del agujero utilizando la punta del perno deslizante como guía.
2. Taladre agujeros de 9/16" (1,4 cm) en las marcas a través de la jamba y la solera.
3. Inserte el receptáculo de la hembra del casquillo en los agujeros de 9/16" (1,4 cm) en la jamba superior y la solera.

NOTA: la puerta NO trancará a menos que ambos pernos estén totalmente extendidos.

Junio 2009 Numero de parte de BMTTMPLQT

<p>SINGLE PIECE CENTER SECTION (Openings less than 52 1/2")</p> <p>Dry fit the pan in the rough opening making sure you have at least 2" of overlap at each joint. Check the center section(s) for proper length and trim as needed. On the sub-floor, where the sill pan will be positioned, apply 3 very large beads of Elastomeric or Polyurethane sealant across the entire width of the opening. Place end pieces tightly against the sides of the rough opening. Liberally coat the underside of the center section where it overlaps the end pieces and the recessed areas of the end pieces with the provided PVC CEMENT ONLY. Hold pieces together long enough to ensure a good bond. Keep in mind that the colder temperatures require longer bonding times. To prevent air infiltration, run a small bead of sealant along the lower interior edge of the pan. Do not apply sealant to the bottom of sill when using a sill pan. Install door unit into sill pan.</p>	<p>MULTIPLE PIECE CENTER SECTION</p> <p>For large rough openings, the center section may be in multiple pieces which overlap to form a continuous pan. Dry fit the pan in the rough opening making sure you have at least 2" of overlap at each joint. Check the center section(s) for proper length and trim as needed. On the sub-floor, where the sill pan will be positioned, apply 3 very large beads of Elastomeric or Polyurethane sealant across the entire width of the opening. Place end pieces tightly against the sides of the rough opening. Liberally coat the underside of the center section where it overlaps the end pieces and the recessed areas of the end pieces with the provided PVC CEMENT ONLY. Hold pieces together long enough to ensure a good bond. Keep in mind that colder temperatures require longer bonding times. To prevent air infiltration, run a small bead of sealant along the lower interior edge of the pan. Do not apply sealant to the bottom of sill when using a sill pan. Install door unit into sill pan.</p>	<p>SECCIÓN CENTRAL DE UNA PIEZA (Aberturas de menos de 133,35 cm)</p> <p>Ajuste el revestimiento en seco en la abertura sin terminar, asegurándose de dejar al menos 5,07 cm de superposición en cada unión. Compruebe que la o las secciones centrales tengan el largo adecuado y, de ser necesario, córtelas. En el subsuelo, en el lugar en donde se colocará el revestimiento, aplique 3 cordones muy anchos de sellador elastomérico o de poliuretano a lo largo de todo el ancho de la abertura. Coloque las piezas de los extremos muy pegados contra los lados de la abertura sin terminar. Cubra generosamente y SOLO con el CEMENTO PARA PVC incluido al lado inferior de la pieza central, en lugar en donde se superponen las piezas de las secciones centrales. Mantenga juntas las piezas el tiempo suficiente para asegurar la formación de una buena adhesión. Recuerde que las temperaturas bajas requieren mayores tiempos de adhesión. Para evitar la filtración de aire, extienda un cordón de masilla de calafateo pequeño a lo largo del borde interior del revestimiento. No calafatee la parte inferior del alféizar si utiliza este revestimiento para alféizar.</p>	<p>SECCIÓN CENTRAL DE VARIAS PIEZAS</p> <p>Para aberturas sin terminar grandes, la sección central puede formarse de varias piezas que se superponen para formar un revestimiento continuo. Ajuste el revestimiento en seco en la abertura sin terminar, asegurándose de dejar al menos 5,08 cm de superposición en cada unión. Compruebe que la o las secciones centrales tengan el largo adecuado y, de ser necesario, córtelas. En el subsuelo, en el lugar en donde se colocará el revestimiento, aplique 3 cordones muy anchos de sellador elastomérico o de poliuretano a lo largo de todo el ancho de la abertura. Coloque las piezas de los extremos muy pegados contra los lados de la abertura sin terminar. Cubra generosamente las áreas superpuestas y las áreas con ranuras de las piezas de los extremos SOLO con el CEMENTO PARA PVC incluido. Mantenga juntas las piezas el tiempo suficiente para asegurar la formación de una buena adhesión. Para evitar la filtración de aire, extienda un cordón de masilla de calafateo pequeño a lo largo del borde interior del revestimiento. No calafatee la parte inferior del alféizar si utiliza este revestimiento para alféizar.</p>
------------------------------------------------------------------------------------------------------------------------------------------------------------------------------------------------------------------------------------------------------------------------------------------------------------------------------------------------------------------------------------------------------------------------------------------------------------------------------------------------------------------------------------------------------------------------------------------------------------------------------------------------------------------------------------------------------------------------------------------------------------------------------------------------------------------------------------------------------------------------------------------------------------------------------------------------------------------------------------------------------------------	----------------------------------------------------------------------------------------------------------------------------------------------------------------------------------------------------------------------------------------------------------------------------------------------------------------------------------------------------------------------------------------------------------------------------------------------------------------------------------------------------------------------------------------------------------------------------------------------------------------------------------------------------------------------------------------------------------------------------------------------------------------------------------------------------------------------------------------------------------------------------------------------------------------------------------------------------------------------------------------------------------------------------------------------------------------------------------------------	------------------------------------------------------------------------------------------------------------------------------------------------------------------------------------------------------------------------------------------------------------------------------------------------------------------------------------------------------------------------------------------------------------------------------------------------------------------------------------------------------------------------------------------------------------------------------------------------------------------------------------------------------------------------------------------------------------------------------------------------------------------------------------------------------------------------------------------------------------------------------------------------------------------------------------------------------------------------------------------------------------------------------------------------------------------------------------------------------------------------------------------------------------------------------------------------------------------------	---------------------------------------------------------------------------------------------------------------------------------------------------------------------------------------------------------------------------------------------------------------------------------------------------------------------------------------------------------------------------------------------------------------------------------------------------------------------------------------------------------------------------------------------------------------------------------------------------------------------------------------------------------------------------------------------------------------------------------------------------------------------------------------------------------------------------------------------------------------------------------------------------------------------------------------------------------------------------------------------------------------------------------------------------------------------------------------------------------------------------------------------------------------------------------------------------------------------------

Label enlarged for clarity.

SINGLE PIECE CENTER SECTION
(Openings less than 52 1/2")

Dry fit the pan in the rough opening making sure you have at least 2" of overlap at each joint. Check the center section(s) for proper length and trim as needed. On the sub-floor, where the sill pan will be positioned, apply 3 very large beads of Elastomeric or Polyurethane sealant across the entire width of the opening. Place end pieces tightly against the sides of the rough opening. Liberally coat the underside of the center section where it overlaps the end pieces and the recessed areas of the end pieces with the provided **PVC CEMENT ONLY**. Hold pieces together long enough to ensure a good bond. **Keep in mind that the colder temperatures require longer bonding times.** To prevent air infiltration, run a small bead of sealant along the lower interior edge of the pan. **Do not apply sealant to the bottom of sill when using a sill pan.** Install door unit into sill pan.

MULTIPLE PIECE CENTER SECTION

For large rough openings, the center section may be in multiple pieces which overlap to form a continuous pan. Dry fit the pan in the rough opening making sure you have at least 2" of overlap at each joint. Check the center section(s) for proper length and trim as needed. On the sub-floor, where the sill pan will be positioned, apply 3 very large beads of Elastomeric or Polyurethane sealant across the entire width of the opening. Place end pieces tightly against the sides of the rough opening. Liberally coat the overlapped areas and the recessed areas of the end pieces with the provided **PVC CEMENT ONLY**. Hold pieces together long enough to ensure a good bond. **Keep in mind that colder temperatures require longer bonding times.** To prevent air infiltration, run a small bead of sealant along the lower interior edge of the pan. **Do not apply sealant to the bottom of sill when using a sill pan.** Install door unit into sill pan.

SECCIÓN CENTRAL DE UNA PIEZA
(Aberturas de menos de 133,35 cm)

Ajuste el revestimiento en seco en la abertura sin terminar, asegurándose de dejar al menos 5,07 cm de superposición en cada unión. Compruebe que la o las secciones centrales tengan el largo adecuado y, de ser necesario, córtelas. En el subsuelo, en el lugar en donde se colocará el revestimiento, aplique 3 cordones muy anchos de sellador elastomérico o de poliuretano a lo largo de todo el ancho de la abertura. Coloque las piezas extremas muy pegados contra los lados de la abertura sin terminar. Cubra generosamente y **SOLO** con el **CEMENTO PARA PVC** incluido al lado inferior de la pieza central, en lugar en donde se superponen las piezas de los extremos y las áreas de ranuras de las piezas extremas. Mantenga juntas las piezas el tiempo suficiente para asegurar la formación de una buena adhesión. Recuerde que las temperaturas bajas requieren mayores tiempos de adhesión. Para evitar la filtración de aire, extienda un cordón de masilla de calafateo pequeño a lo largo del borde interior del revestimiento. Instale la puerta en el revestimiento. No calafatee la parte inferior del alféizar si utiliza este revestimiento para alféizar.

SECCIÓN CENTRAL DE VARIAS PIEZAS

Para aberturas sin terminar grandes, la sección central puede formarse de varias piezas que se superponen para formar un revestimiento continuo. Ajuste el revestimiento en seco en la abertura sin terminar, asegurándose de dejar al menos 5,08 cm de superposición en cada unión. Compruebe que la o las secciones centrales tengan el largo adecuado y, de ser necesario, córtelas. En el subsuelo, en el lugar en donde se colocará el revestimiento, aplique 3 cordones muy anchos de sellador elastomérico o de poliuretano a lo largo de todo el ancho de la abertura. Coloque las piezas de los extremos muy pegados contra los lados de la abertura sin terminar. Cubra generosamente las áreas superpuestas y las áreas con ranuras de las piezas de los extremos **SOLO** con el **CEMENTO PARA PVC** incluido. Mantenga juntas las piezas el tiempo suficiente para asegurar la formación de una buena adhesión. Para evitar la filtración de aire, extienda un cordón de masilla de calafateo pequeño a lo largo del borde interior del revestimiento. No calafatee la parte inferior del alféizar si utiliza este revestimiento para alféizar.

100-204188

Site Installation Instructions for Aluminum Astragal

The following instructions are for steps which can be completed in the shop or at the site after unit installation.

If the following steps are to be done at the site, the Astragal Site Pack along with these instructions should be attached to the pre-hung unit.

If the following steps are done in the shop, attach this instruction sheet along with the (8) long hinge screws to the pre-hung unit.

Read all instructions before starting.

THERMA-TRU®

The Most Preferred Brand in the Business

Stock# 5134141

Astragal Site Pack Contents



Fill Plug

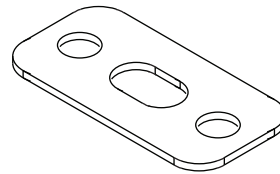

Keeper Plate

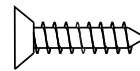

(2) #6 x 1"
Phillips Flat Head

Keeper Plate Screws

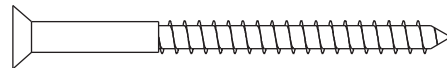

(8) #10 x 2-1/2"
Phillips Flat Head

Hinge Screws - Jamb Leaf

THERMA-TRU®

The Most Preferred Brand in the Business

1750 Indian Wood Circle
Maumee, Ohio 43537
419-891-7400

©1994-2004 Therma-Tru Corp. All rights reserved.

Therma-Tru Doors is an operating company of Fortune Brands, Inc.

1 APPLY SEALANT AND MARK SLIDE BOLT ENDS.

Extend slide bolts and place sealant on each tip. Sealant will be used to mark hole locations.

Retract bolt.

With inactive door held in closed position, and door flush with frame, extend slide bolts to mark head and sill.

Retract bolts.

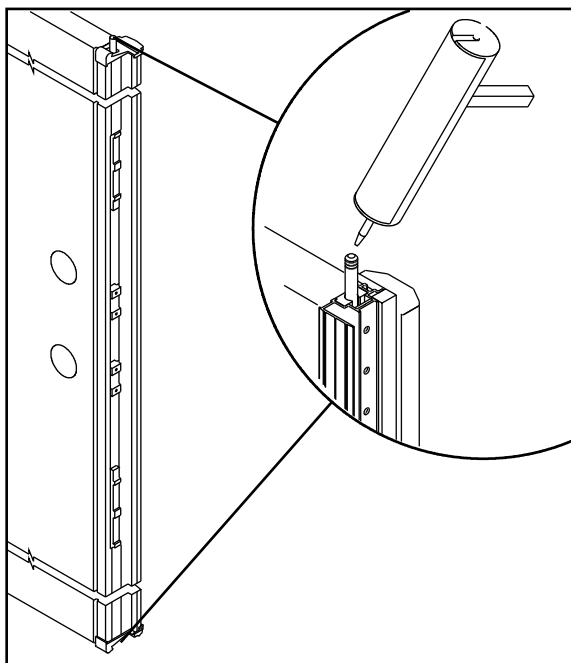

2 DRILL HEAD AND SILL BOLT HOLES.

Open door and drill 3/8" diameter hole at overhead in wood frame.

Drill 7/16" diameter hole through threshold.

Fill threshold hole with sealant.

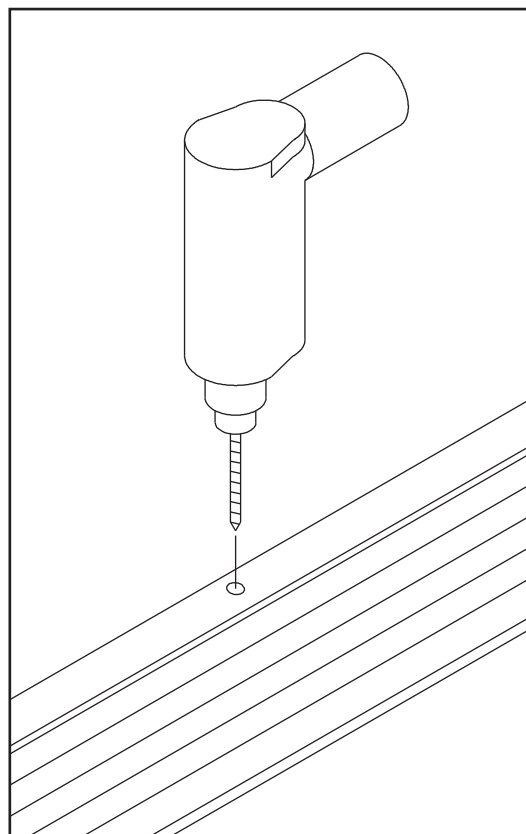

Rev. 11/19/02

3 INSERT ASTRAGAL FILL PLUG INTO THRESHOLD.

Fit should be tight, sealant will act as adhesive.

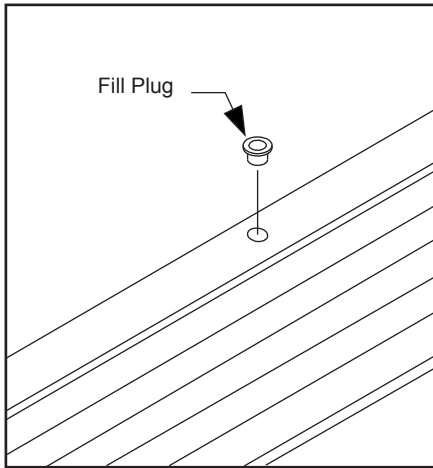

4 INSTALL KEEPER PLATE.

Position brass keeper plate as shown at overhead hole.

Fasten plate with (2) #6 x 1" screws.

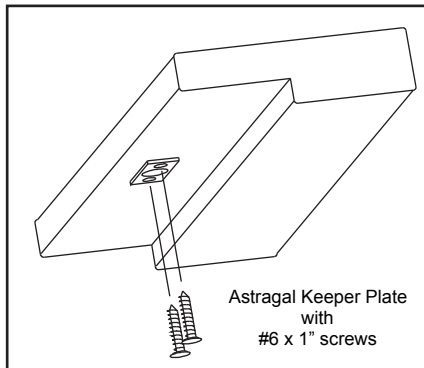

5 INSTALL LONG HINGE SCREWS (SITE ONLY).

With door open, at hinges where labels indicate, drill 1/8" dia. pilot holes and drive #10 x 2-1/2" screws through hinges to anchor door frame and prevent sagging.

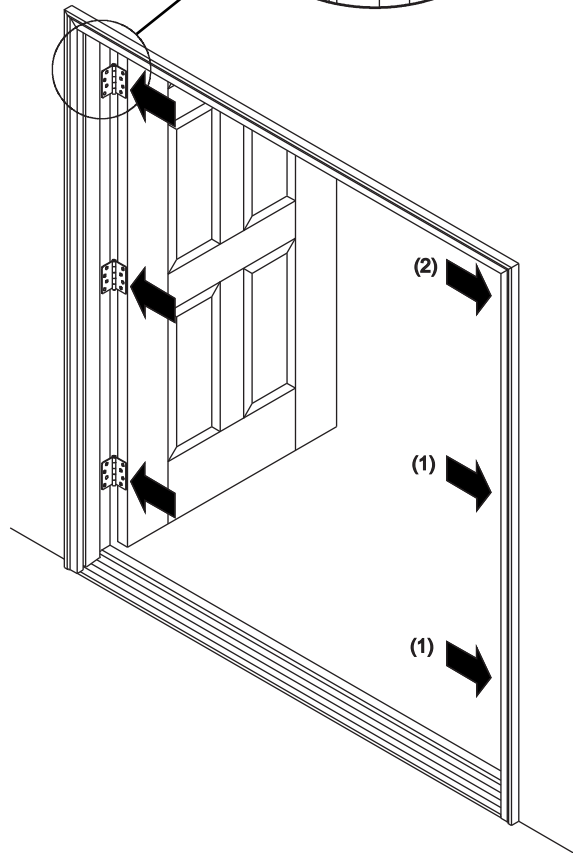
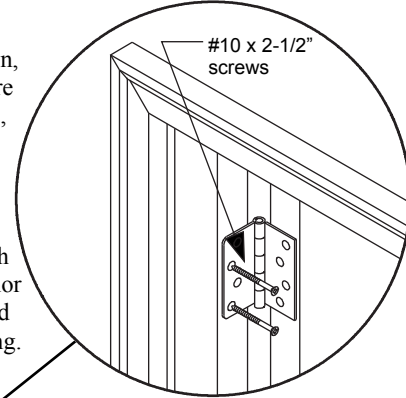

100-204195

Multi-Point Shootbolt Astragal Assembly & Installation Instructions

The following instructions are for steps which can be completed in the shop or at the site after unit installation for Double Door units with Multi-Point Locks

Read all instructions before starting.

THERMA TRU
The Most Preferred Brand in the Business

Rev.D 8/17/04

Stock# 5134143

Multi-Point Astragal Pack Contents

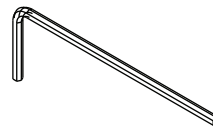

Hex Key

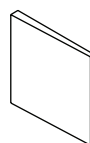

Corner Seal Pad

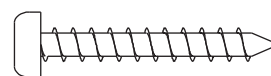

(9) #10 x 1 1/2"
Phillips Pan Head

Astragal Mounting
Screws

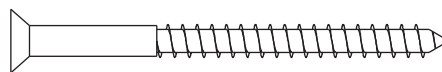

(8) #10 x 2-1/2"
Phillips Flat Head

Hinge Screws - Jamb Leaf

Strike Plates and Strike Plate Fasteners do not come with the astragals. They are purchased separately. Contact your Therma-Tru Customer Relations Representative for the correct strike plate package.

THERMA TRU

The Most Preferred Brand in the Business

1750 Indian Wood Circle
Maumee, Ohio 43537
419-891-7400

©1994-2004 Therma-Tru Corp. All rights reserved.

Therma-Tru Doors is an operating company of Fortune Brands, Inc.

Multi-Point Shootbolt Paintable & Stainable Astragal Installation Instructions

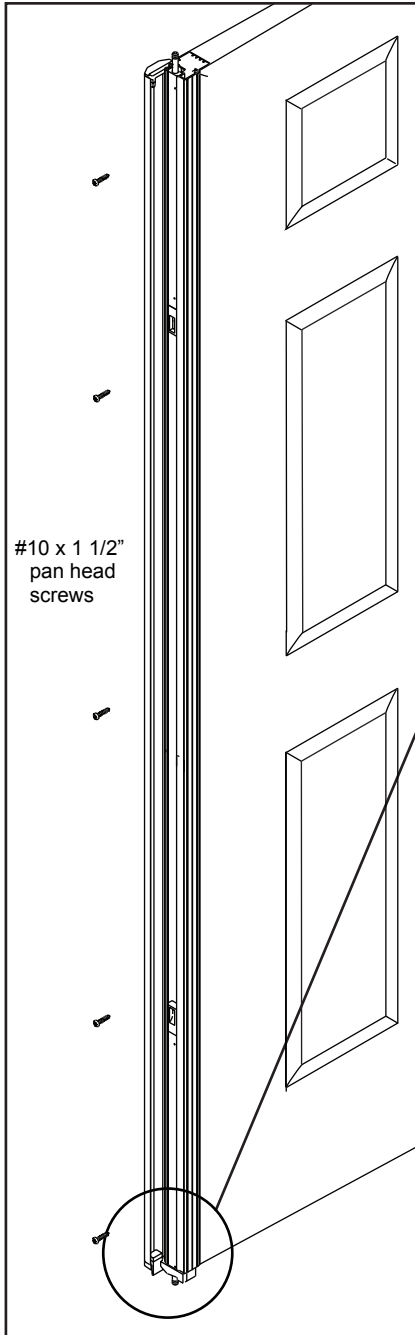

#10 x 1 1/2"
pan head
screws

1 SET ASTRAGAL ON DOOR.

NOTE: If deadbolt is **NOT** used, deadbolt strike boss should be removed. Press thru back of astragal or slide to latch position and remove.

Align astragal to slab which is to be "fixed".

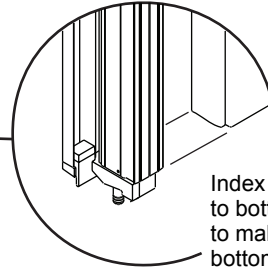

Index end of aluminum
to bottom edge of slab
to make flush with
bottom of door.

2 DRILL AND SECURE ASTRAGAL.

Pre-drill for mounting thru the astragal mounting holes into the fixed door using 1/8" dia. bit.

For astragal with 17" slide bolts, once the top and bottom holes have been pre-drilled, install #10 x 1-1/2" mounting screws. Then loosen the set screws in the retainers, place flush with the ends, and re-tighten set screws. Pre-drill remaining holes and install remaining #10 x 1-1/2" mounting screws.

(Note: upper and lower mounting screws also secure the bolt spring clip.)

#10x1-1/2"

Pan Head Screw

Retainer

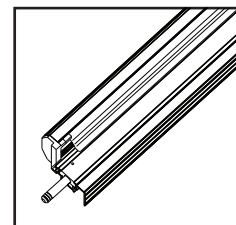
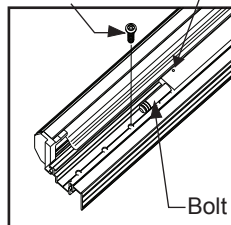

Bolt

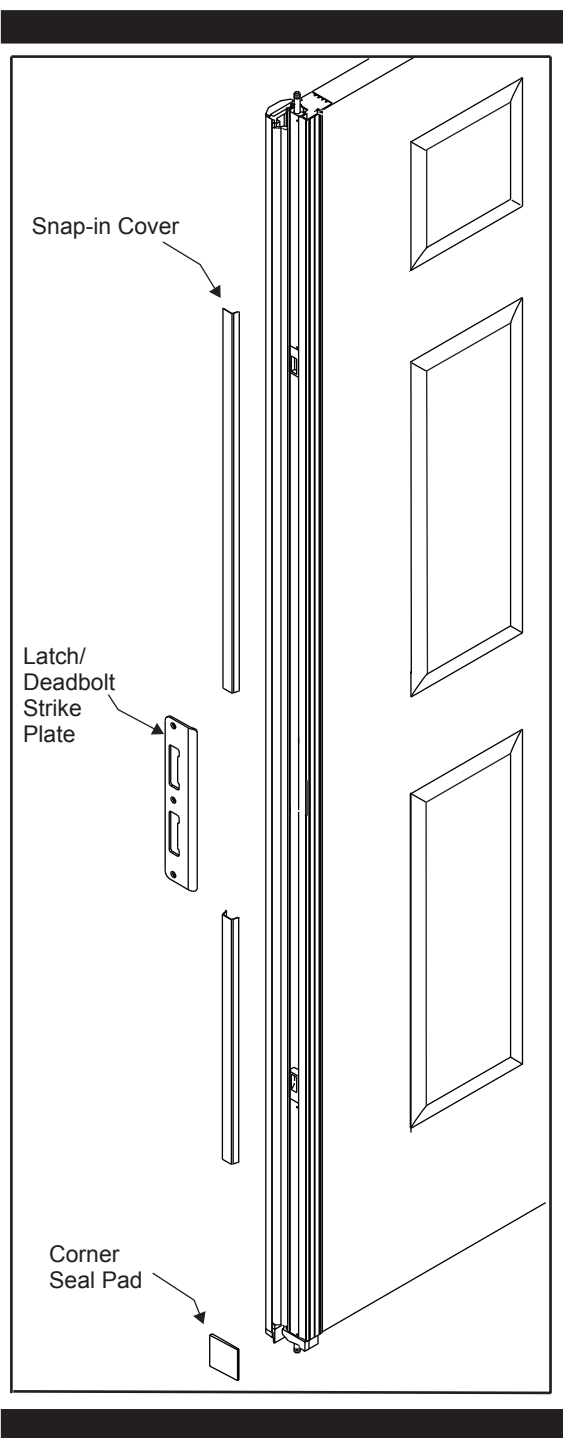

3 FASTEN STRIKE PLATE ASSEMBLY.
(Sold Separately)

Position latch/deadbolt strike plate in mortised pocket on astragal using screws provided in Multi-Point Strike Plate Package

4 APPLY SNAP-IN COVER.

Align longer snap-in cover with top of strike plate and snap into place. Trim to length of astragal.

Align shorter snap-in cover with bottom of strike plate and snap into place. Trim to length of astragal.

5 APPLY CORNER SEAL PAD.



CAUTION:
Corner seal pads are only used with inswing units.

Apply corner seal pad against weatherstrip with bottom edge in line with bottom edge of seal.

6 INSTALL LONG HINGE SCREWS (SITE ONLY).

With door open, at hinges where labels indicate, drill 1/8" dia. Pilot holes and drive #10 x 2-1/2" (2-top, 1-middle, 1-bottom) screws through hinges to anchor door frame and prevent sagging.

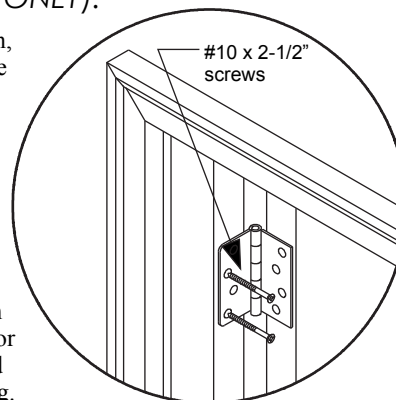

Site Installation Instructions for Coastal Astragal 2

The following instructions should be completed at the unit installation site.

The hardware pack contains all the necessary hardware and fasteners needed to complete this installation.

Read all instructions before starting.

THERMA TRU®
The Most Preferred Brand in the Business

Rev. A 3/8/06

P/N: CA2STIS

1 APPLY SEALANT AND MARK SLIDE BOLT ENDS.

Extend slide bolts and place sealant on each tip. Sealant will be used to mark hole locations.

Retract bolt.

With inactive door held in closed position, and door flush with frame, extend slide bolts to mark head and sill.

Retract bolts.

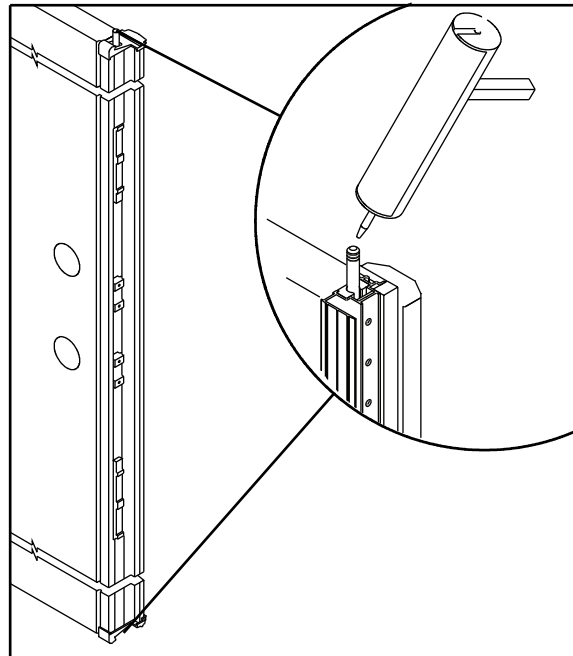

2 DRILL HEAD AND SILL BOLT HOLES.

Open door and drill 3/8" diameter hole at overhead in wood frame 2" deep.

Drill 1/2" diameter hole through threshold 2-1/4" deep. If sub-floor material is masonry, a 1/2" diameter masonry drill bit will be needed to complete hole.

Apply significant amount of sealant to threshold hole to seal sub-floor interface area.

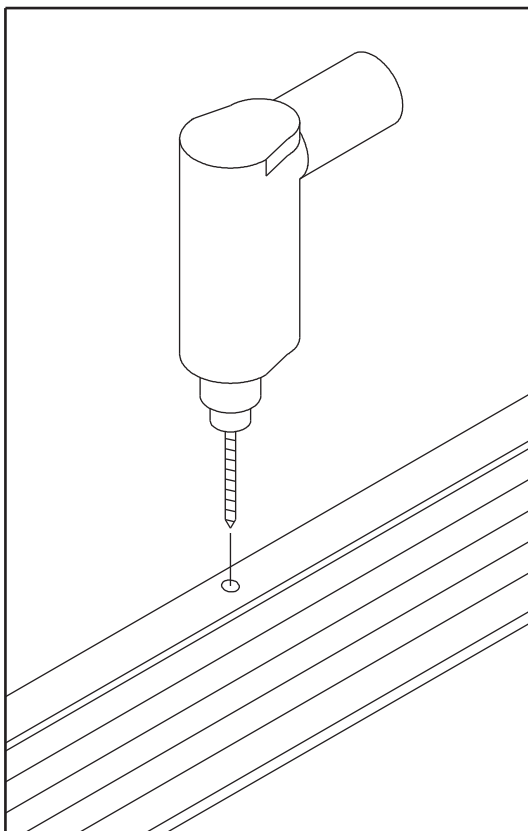

Rev. 12/20/02

3 INSERT ASTRAGAL FILL PLUG INTO THRESHOLD.

Apply additional sealant to underside of lip of sill plug.

Fit should be tight, sealant will act as adhesive.

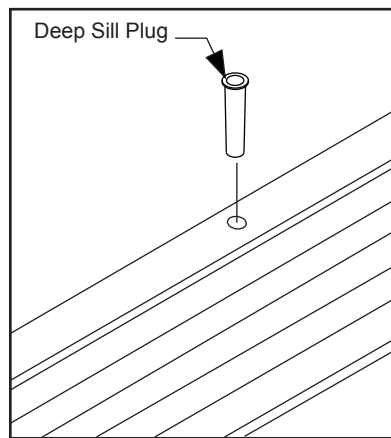

4 INSTALL KEEPER PLATES.

Position keeper plates as shown at overhead and sill holes.

Fasten plates with (2) #8 x 2-1/2" screws.

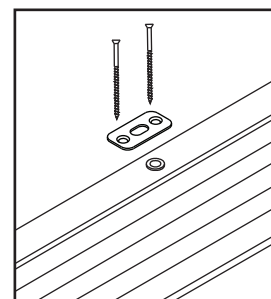
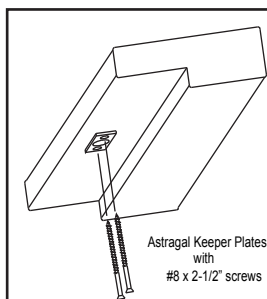

Coastal Astragal 2 Installation Instructions

5 INSTALL LONG HINGE SCREWS.

With door open, at hinges where labels indicate, drill 1/8" dia. pilot holes and drive #10 x 2-1/2" screws through hinges to anchor door frame and prevent sagging.

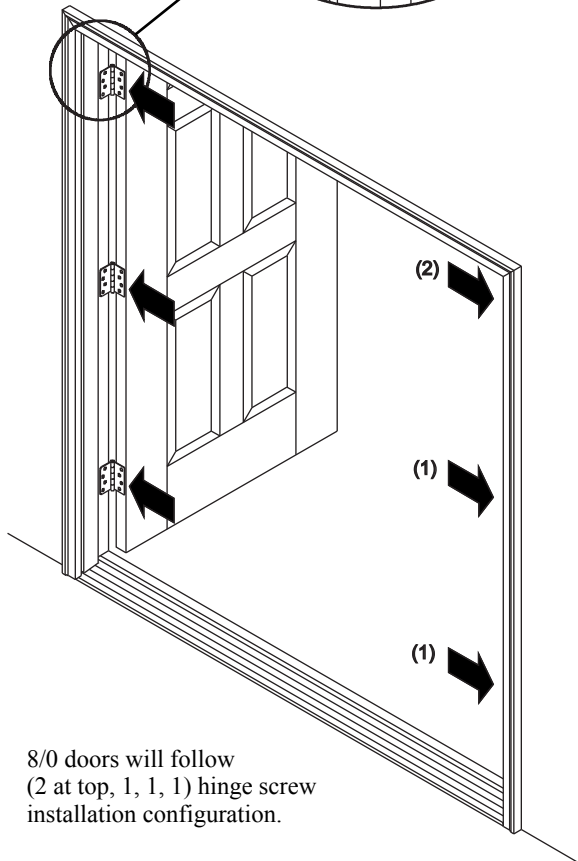
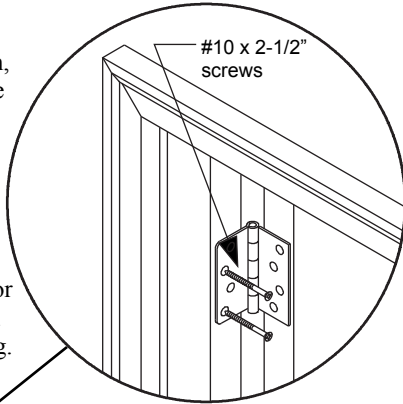

8/0 doors will follow (2 at top, 1, 1, 1) hinge screw installation configuration.

Coastal Astragal 2 Site Pack Contents

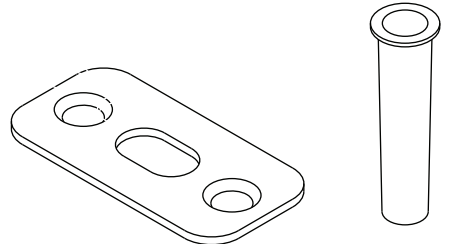

(2) Keeper Plate

Deep Sill Plug



(4) #8 x 2-1/2" Phillips Flat Head

Keeper Plate Screws

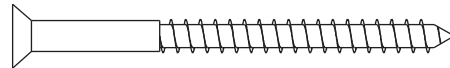

(10) #10 x 2-1/2" Phillips Flat Head

Hinge Screws - Jamb Leaf

THERMA TRU[®]

The Most Preferred Brand in the Business

1750 Indian Wood Circle
Maumee, Ohio 43537
419-891-7400

Therma-Tru is a registered trademark of Therma-Tru Corp.
© 2006 Therma-Tru Corp.

Site Installation Instructions for Multi-Point Shootbolt Coastal Astragal 2

The following instructions should be completed at the unit installation site.

The hardware pack contains all the necessary hardware and fasteners needed to complete the installation of the astragal unit.

Read all instructions before starting.

THERMA TRU®
The Most Preferred Brand in the Business

Rev. A 3/8/06

P/N: CA2MPLSSITE

1 APPLY SEALANT AND MARK SLIDE BOLT ENDS.

Extend slide bolts and place sealant on each tip. Sealant will be used to mark hole locations.

Retract bolt.

With inactive door held in closed position, and door flush with frame, extend slide bolts to mark head and sill.

Retract bolts.

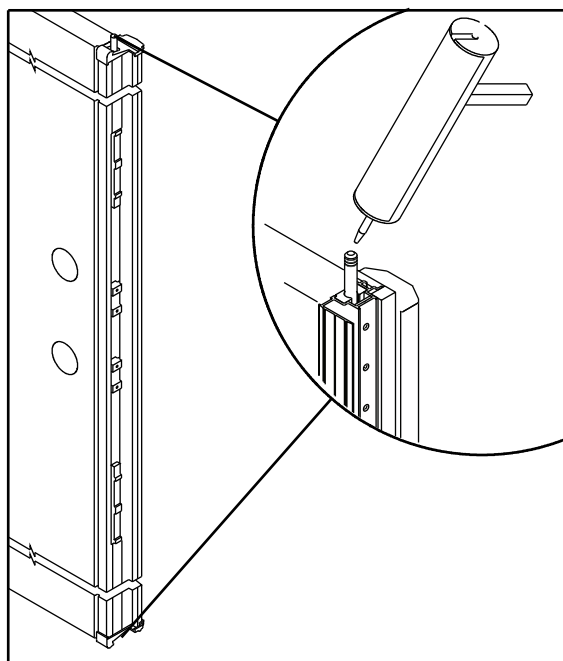

Multi-Point Shootbolt Coastal Astragal 2 Installation Instructions

THERMA TRU®
DOORS

2 DRILL HEAD AND SILL BOLT HOLES.

Open door and drill 3/8" diameter hole at overhead in wood frame 2" deep.

Drill 1/2" diameter hole through threshold 2-1/4" deep. If sub-floor material is masonry, a 1/2" diameter masonry drill bit will be needed to complete hole.

Apply significant amount of sealant to threshold hole to seal sub-floor interface area.

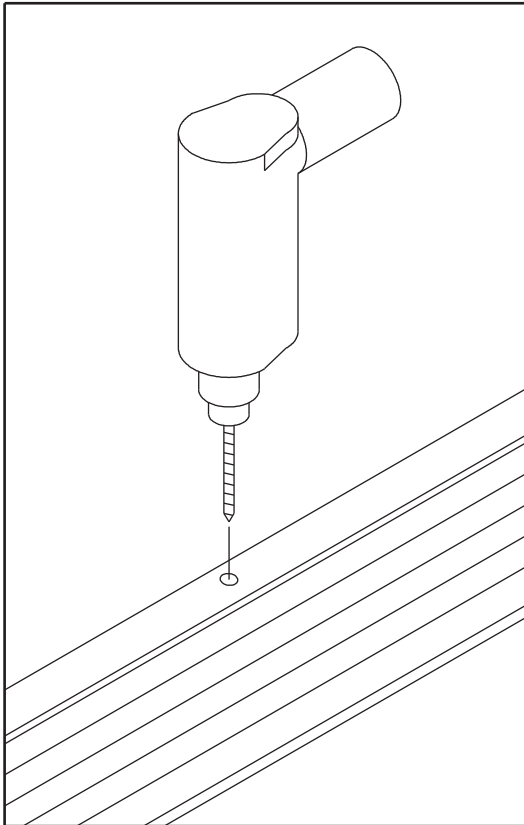

Rev. 12/20/02

3 INSERT ASTRAGAL FILL PLUG INTO THRESHOLD.

Apply additional sealant to underside of lip of sill plug.

Fit should be tight, sealant will act as adhesive.

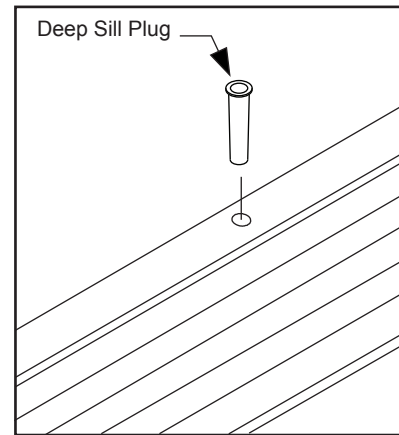

4 INSTALL KEEPER PLATES.

Position keeper plates as shown at overhead and sill holes.

Fasten plates with (2) #8 x 2-1/2" screws.

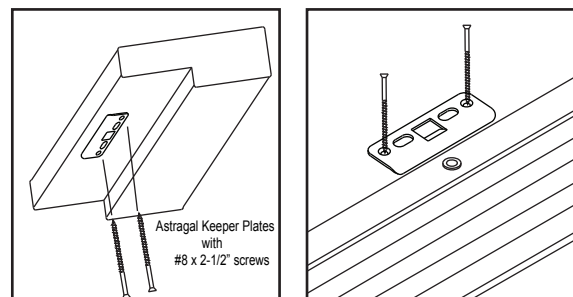

5 INSTALL LONG HINGE SCREWS.

With door open, at hinges where labels indicate, drill 1/8" dia. pilot holes and drive #10 x 2-1/2" screws through hinges to anchor door frame and prevent sagging.

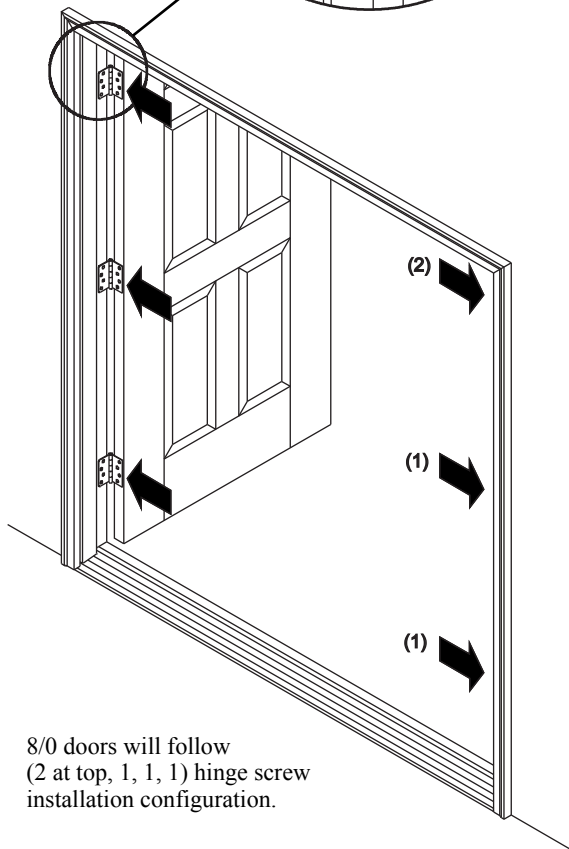
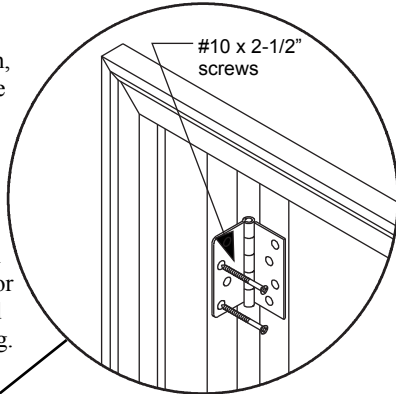

8/0 doors will follow (2 at top, 1, 1, 1) hinge screw installation configuration.

Coastal Astragal 2 Site Pack Contents

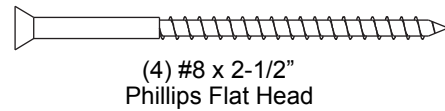
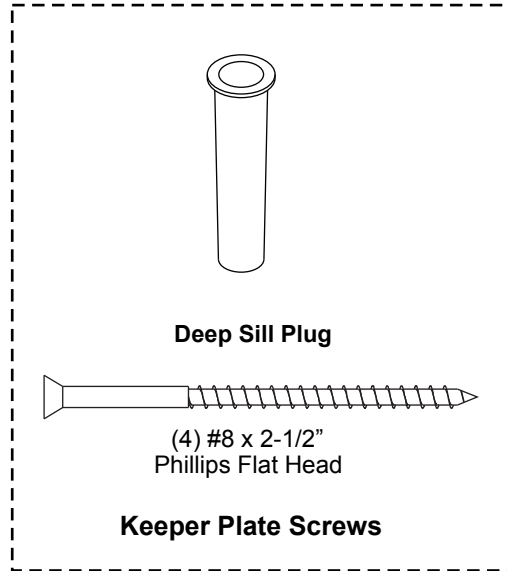

Keeper Plate Screws

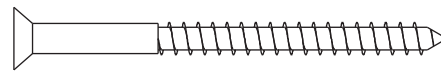

Hinge Screws - Jamb Leaf

Strike Plates and Strike Plate Fasteners do not come with the astragals. They are purchased separately. Contact your Therma-Tru Customer Relations Representative for the correct strike plate package.



The Most Preferred in the Business

1750 Indian Wood Circle
Maumee, Ohio 43537
419-891-7400

Therma-Tru is a registered trademark of Therma-Tru Corp.
© 2006 Therma-Tru Corp.

French Door System Outswing Astragal Security Cover Installation

Attach Outswing Astragal Security Cover (Optional)
(Not available for Coastal Astragal applications.)

7/8" Aluminum Outswing Astragal Security Cover (Optional)

Fasten with (9) #8 x 5/8" Phillips pan head stainless steel screws.

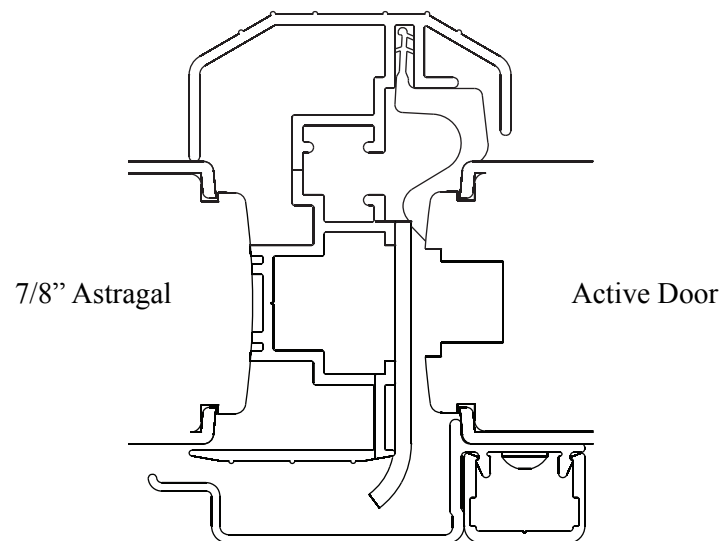

Installation Instructions for Transom Units



Single Door

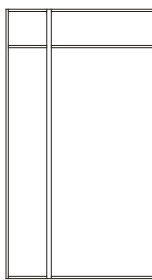

Mulled Sidelite

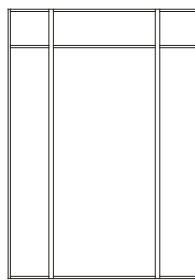

Mulled Sidelites
Separated Sills

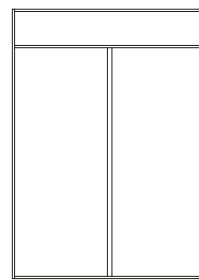

Patio

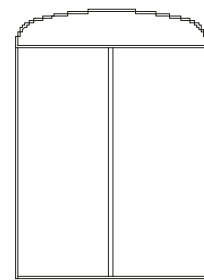

Patio

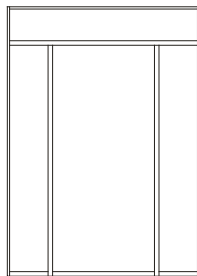

Mulled Sidelites
Separated Sills

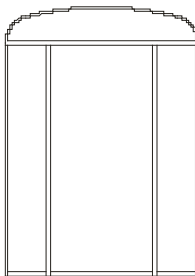

Mulled Sidelites
Separated Sills

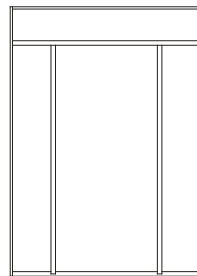

Continuous Head/Sill
and Mullions

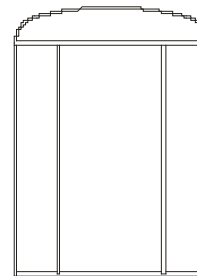

Continuous Head/Sill
and Mullions

Read all instructions before starting.

THERMA TRU
DOORS

Transom Installation Instructions

1 ASSEMBLE JAMB EXTENDERS IF USING 6-5/8" JAMBS.

Measure transom frame width and height.

The following are recommended height and width dimensions. Use actual measurements to construct jamb extender frame.

Height: 13-15/32"

Door/Sidelite Slab	Width
14" Sidelite	14"
12" Sidelite	12"
3/0	36-5/32"
5/0 Patio	64-5/16"
5/4 Patio	68-5/16"
5/8 Patio	72-5/16"
6/0 Patio	76-5/16"
3/0 w/12" S/L, Mulled	62-5/32"
3/0 w/12" S/L, Boxed.	63-5/32"
3/0 w/14" S/L, Mulled	66-5/32"
3/0 w/14" S/L, Boxed	67-5/32"

Cut extender components to match transom dimensions.

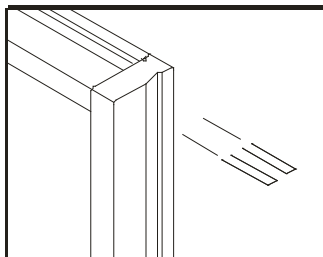
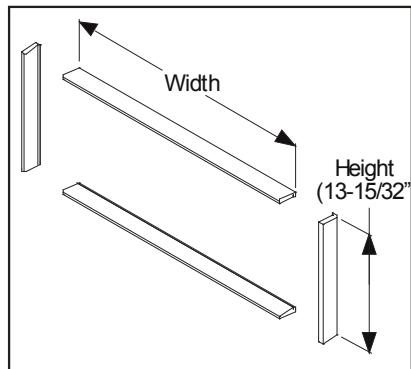

Butt corners together and fasten with 2 staples or nails.

2 APPLY JAMB EXTENDERS IF APPLICABLE.

Align extender with transom. Orient so V-groove for fastening is closer to transom frame.

Fasten entire perimeter, as shown, through V-groove. Use 1" brads on 6" centers.

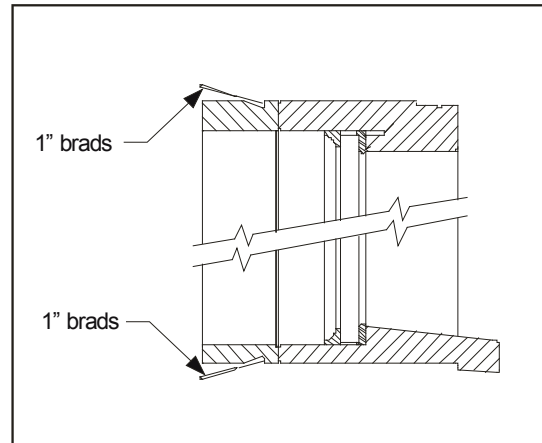

Align extension jamb with transom jamb so inside surface of extension jamb is flush with inside surface of transom jamb, and relief notch is against transom jamb.

Nail and countersink extension jamb to transom jamb with #8 finishing nails in pre-drilled holes.

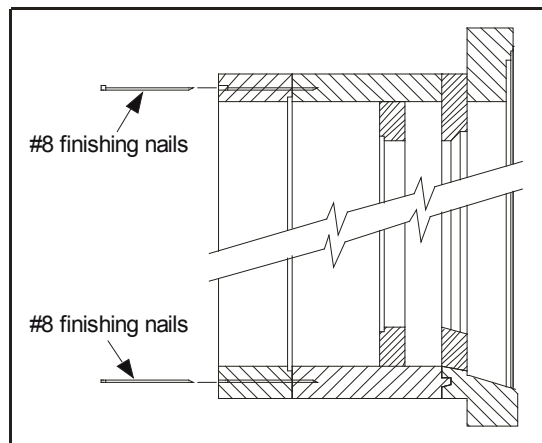

3 WIDTH-MATCH MULLED UNITS.

When jamb-stitched ("mulled") and then stacked with transoms, units require special attention. Width and thickness tolerances can work against the assembler. Width checking is required and shimming may be necessary.

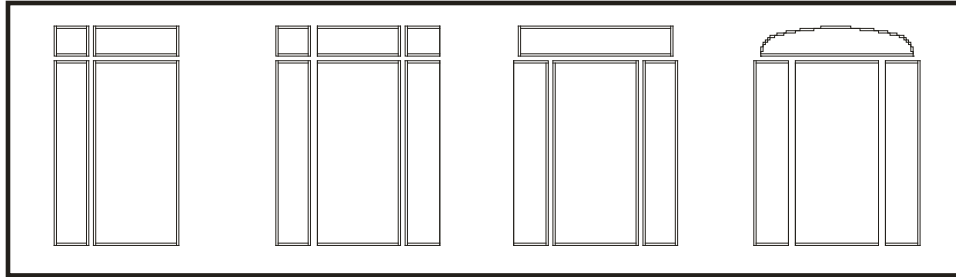

Place Units Together To Check Fit

Apply a 1/4" bead of sealant (Elastomeric or Polyurethane) entire length between units as shown.

Lay door, sidelite and transom units on a flat surface with exterior sides facing up.

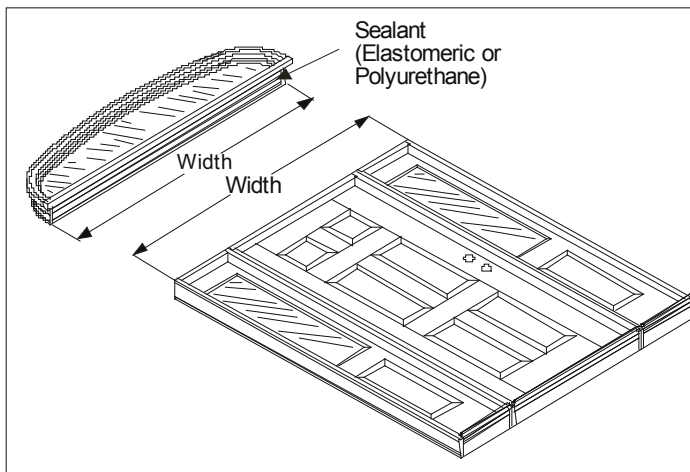
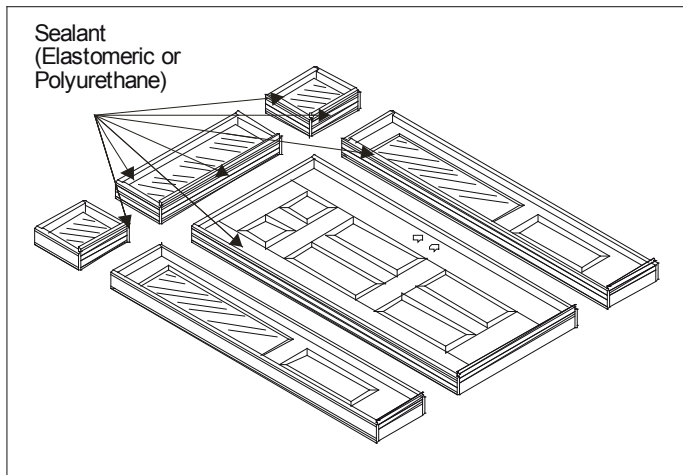

Measure widths and compare.

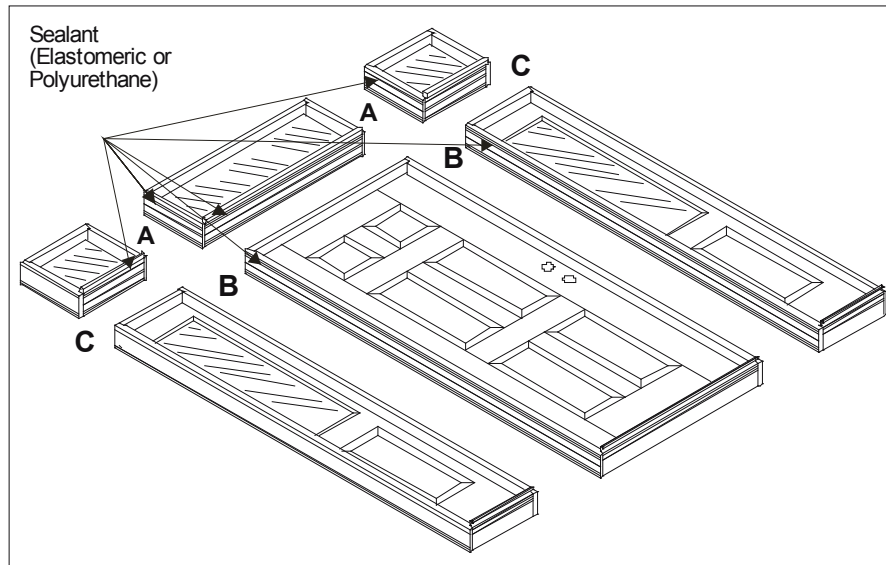
3 WIDTH-MATCH MULLED UNITS. (CONT.)**Shim or Remove Material Where Required To Match Widths**

Shim between jambs at A or B so widths match at C.

If material needs to be removed, use a power planer or belt sander on back side of jamb where required.

Apply a 1/4" bead of sealant (Elastomeric or Polyurethane) entire length between units as shown.

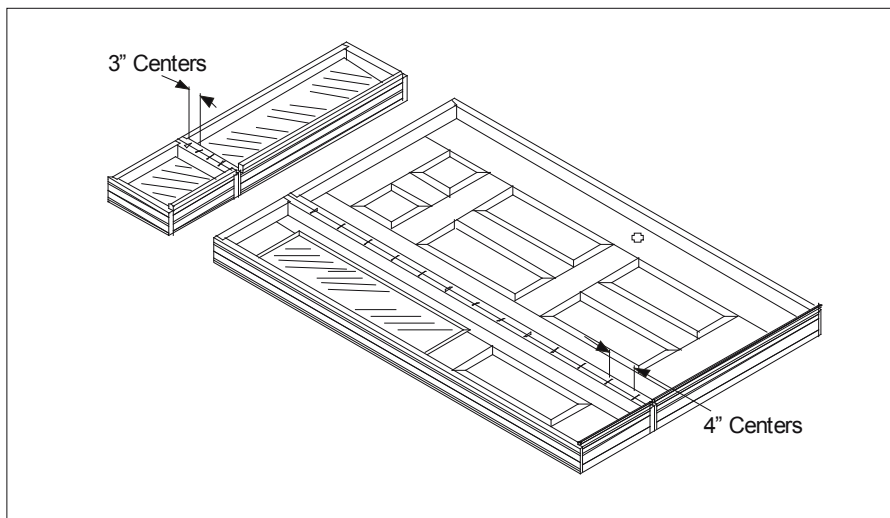
**Stitch-Fasten Jambs**

Draw jambs together and stitch fasten at interior side across joint with 1" corrugated fasteners.

Fasten door unit at 4" centers.

Fasten transom unit at 3" centers.

4 ATTACH TRANSOM TO DOOR UNIT.

Draw units together tightly.

Fasten with 1" corrugated fasteners or gusset plate.

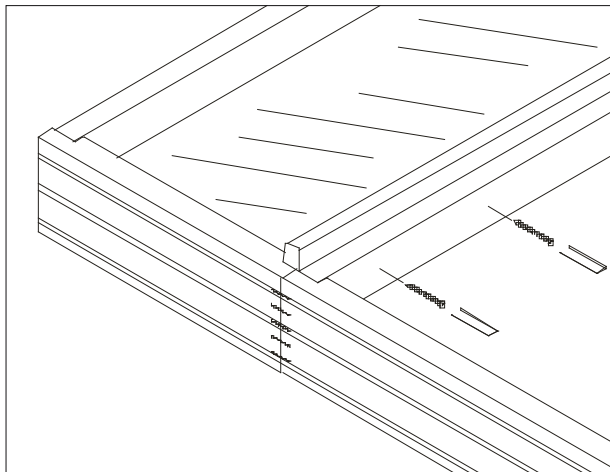
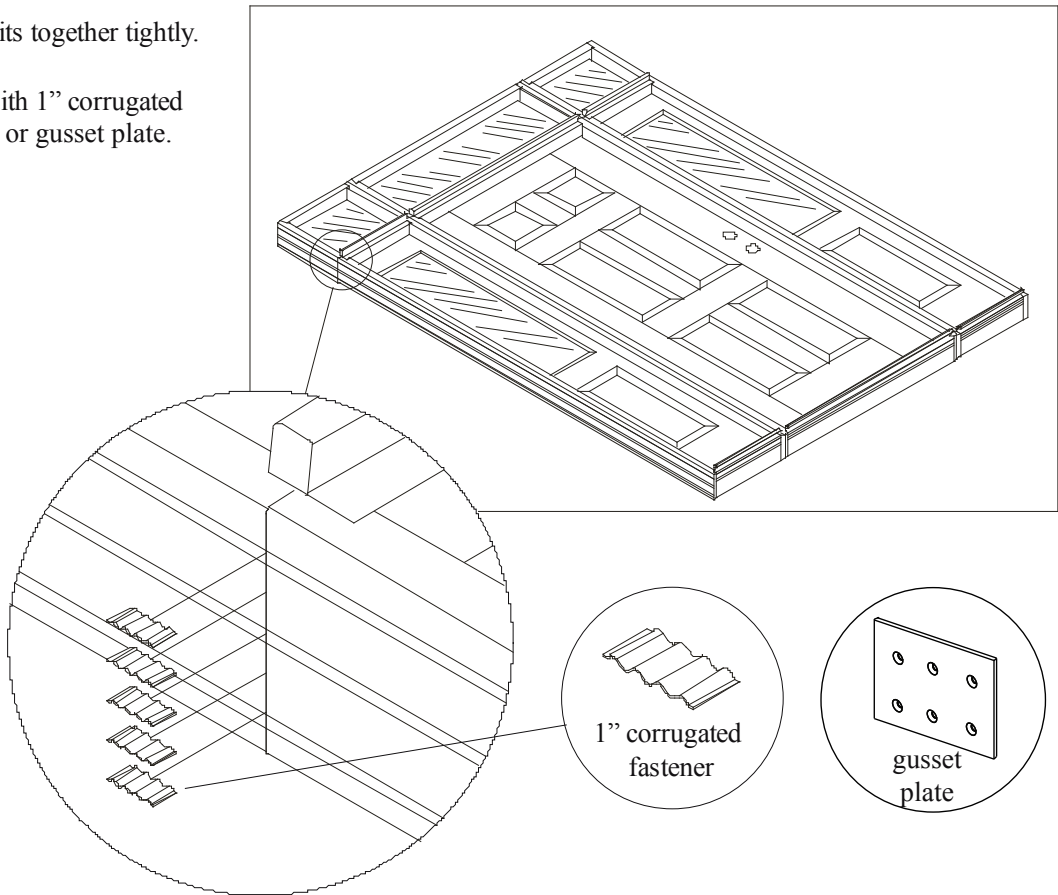

Draw head to transom sill and clamp if required.

Using 2" screws or staples spaced on 6" centers, fasten through door/sidelite frame heads into transom sill.

Transom Installation Instructions

5 CUT BRICKMOULD TO SIZE. (RECTANGULAR TRANSOM)



CAUTION:

The following four steps apply only to units with rectangular transoms.
For units with elliptical transoms proceed to step 9.

		LENGTH	
		DOOR HEIGHT	INSWING
BOOK	6/6	94-1/4"	93-5/32"
	6/8	96-3/4"	95-21/32"
	7/0	100-3/4"	99-21/32"
	8/0	112-3/4"	111-21/32"
U1	6/6	92-7/32"	91-5/8"
	6/8	94-9/16"	93-31/32"
	7/0	98-9/16"	97-31/32"
	8/0	110-9/16"	109-31/32"
U1REV	6/8	94-3/8"	93-31/32"
	8/0	110-3/8"	109-31/32"

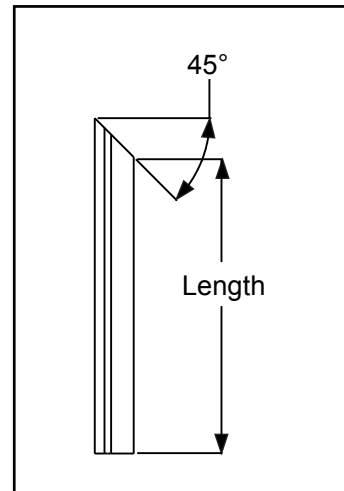

JAMB BRICKMOULD

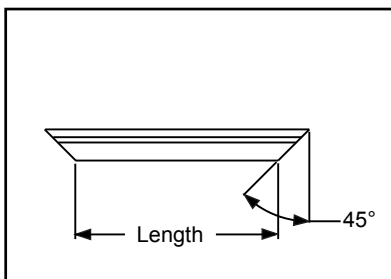

HEAD BRICKMOULD

	Unit Size	Head Length Inswing	Head Length Outswing
Single Units	3/0	34-5/32"	34-21/32"
Continuous Sill Units	3/0 - (2) 12"	62-5/32"	————
	3/0 - (2) 14"	66-5/32"	————
Mulled Units	3/0 - (2) 12"	59-5/32"	59-21/32"
	3/0 - (2) 14"	67-5/32"	67-21/32"
Patio Units	5/0	61-5/16"	61-13/16"
	5/4	65-5/16"	65-13/16"
	5/8	69-5/16"	69-13/16"
	6/0	73-5/16"	73-13/16"

6 FASTEN BRICKMOULD TO SIDE JAMBS.

Locate and attach brickmould jamb pieces.

Fasten brickmould with 2-1/2" staples or finish nails starting 1/2" in from end and spaced approximately 8" apart.

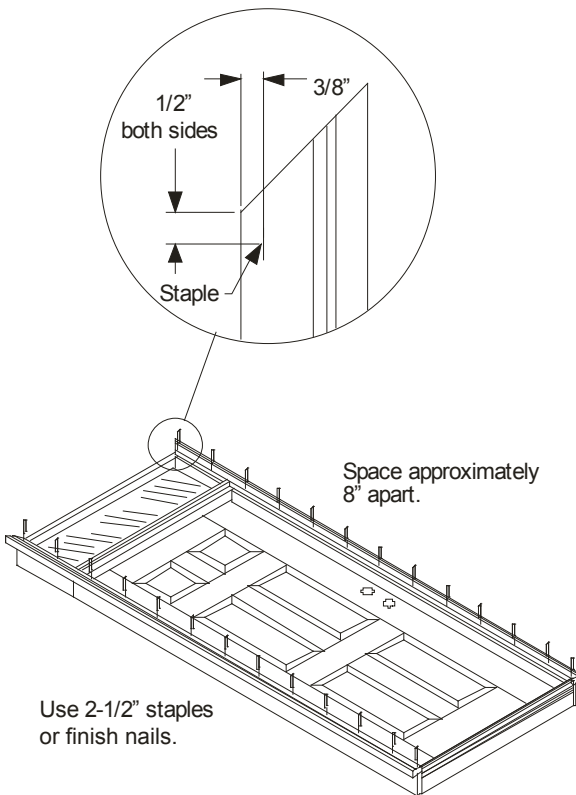
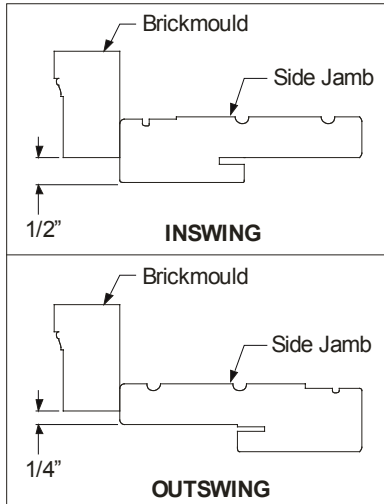

7 FASTEN BRICKMOULD TO FRAME HEAD.

Align brickmould head at corner miters.

Fasten near ends to jambs with 2-1/2" staples or finish nails.

Hold proper 1/2" or 1/4" reveal and staple to jamb across length at approximately 8" spacing.

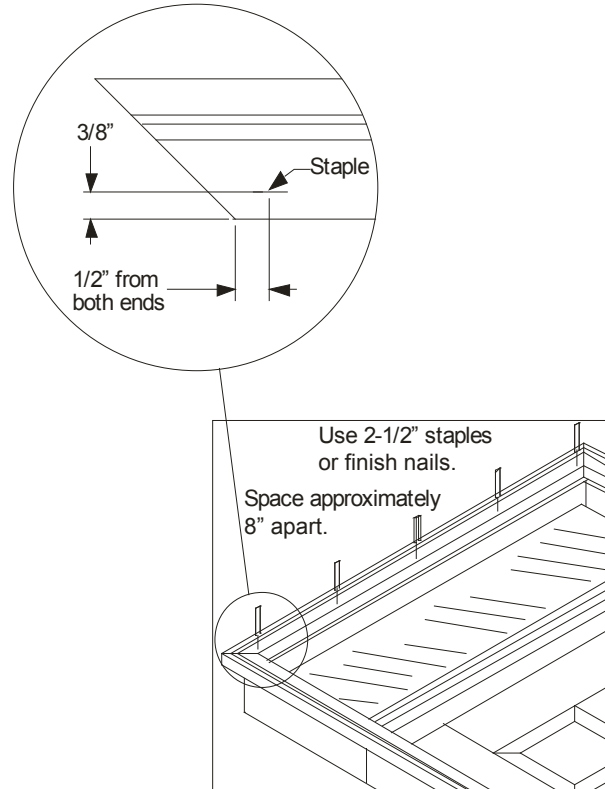
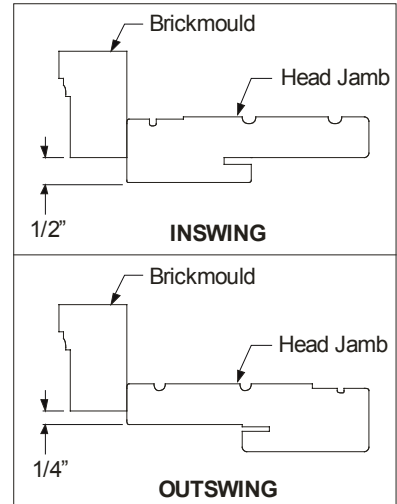

Transom Installation Instructions

8 SECURE CORNERS AND CAULK REMAINING GAPS.

Secure each corner with (2) 2-1/2" staples, one applied through head piece and one applied through jamb length.

Caulk remaining gaps and remove excess.

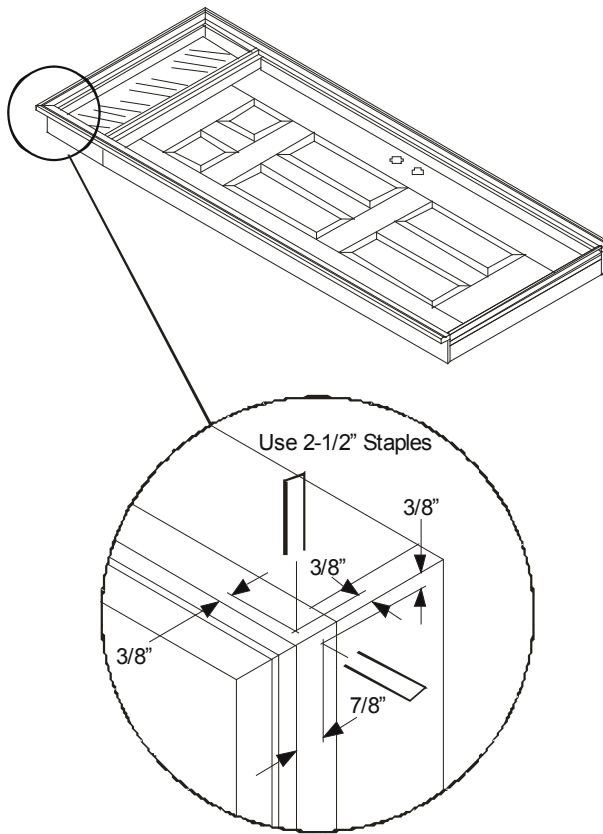

9 CUT BRICKMOULD TO SIZE. (ELLIPTICAL TRANSOM)



CAUTION:

The following two steps apply only to units with elliptical transoms.

		LENGTH	
		DOOR HEIGHT	
BOOK		6/6	94-1/4" 93-5/32"
		6/8	96-3/4" 95-21/32"
		7/0	100-3/4" 99-21/32"
		8/0	112-3/4" 111-21/32"
U1		6/6	92-7/32" 91-5/8"
		6/8	94-9/16" 93-31/32"
		7/0	98-9/16" 97-31/32"
		8/0	110-9/16" 109-31/32"
U1REV		6/8	94-3/8" 93-31/32"
		8/0	110-3/8" 109-31/32"

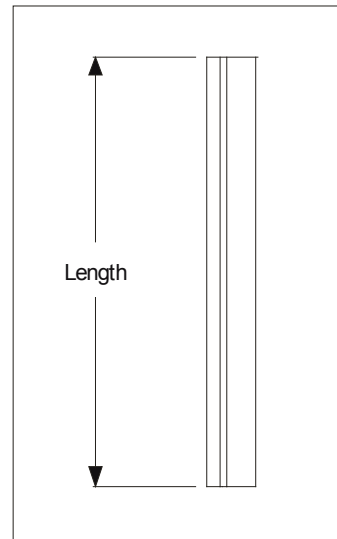

JAMB BRICKMOULD

10 FASTEN BRICKMOULD TO SIDE JAMBS.

Locate and attach brickmould jamb pieces.

Fasten brickmould with 2-1/2" staples starting 1/2" in from end and spaced approximately 8" apart.

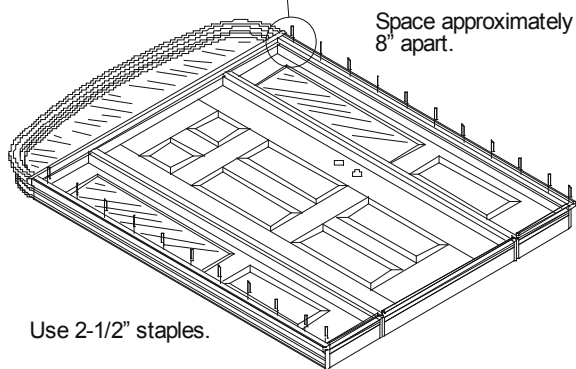
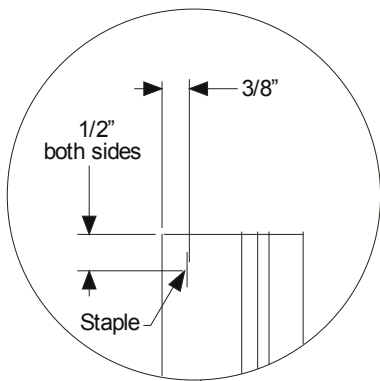
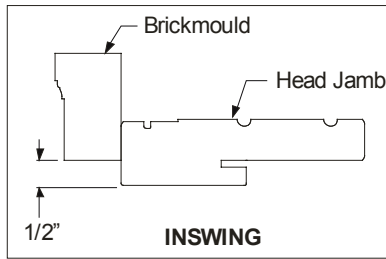

11 CUT MULL CASING TO PROPER LENGTH AND APPLY.

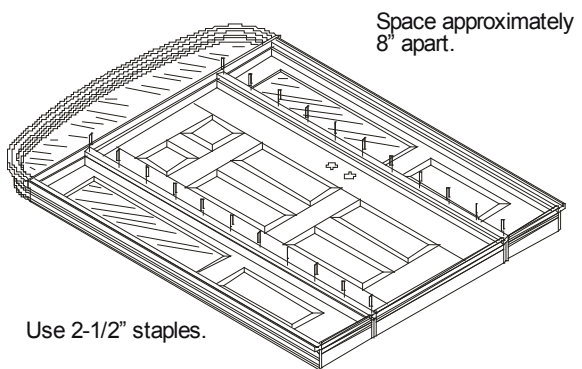
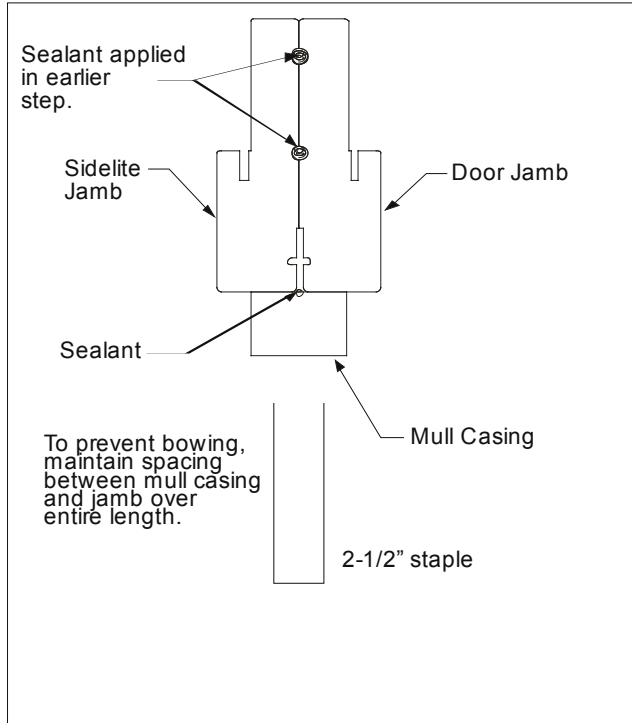

12 FINAL TRANSOM ATTACHMENT TO DOOR.

Turn entire unit over.

Stitch-fasten at exterior side across joint with 1" corrugated fasteners.

Fasten door unit at 4" centers.

Fasten transom unit at 3" centers.

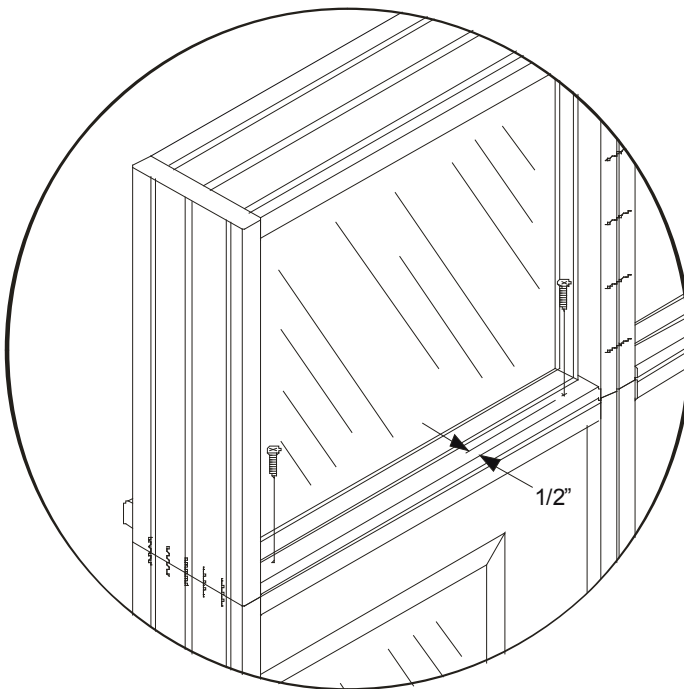
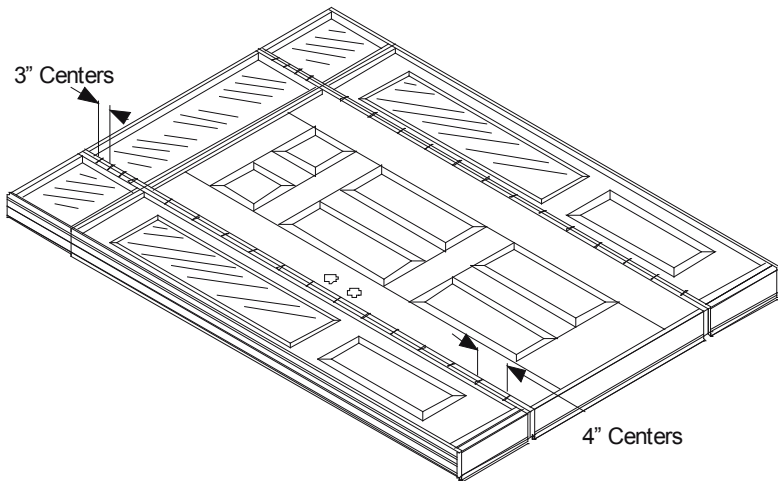

Draw head/sill joint together and clamp if required.

Screw or staple down through transom sill into door/sidelite frame heads.

Fasten along a line approximately 1/2" in from edge as shown.

Space on 6" centers.

Rectangular transoms require 1" fasteners. Elliptical transoms require 1-1/2" fasteners.

13 **INSTALL TRANSOM GRILLE (OPTIONAL)**

Use table below for location of grille bars.

Measure from inside edge of transom jamb and place a mark on the sill approximately 3/4" from inside edge of sill.

Mark transom head in same manner.

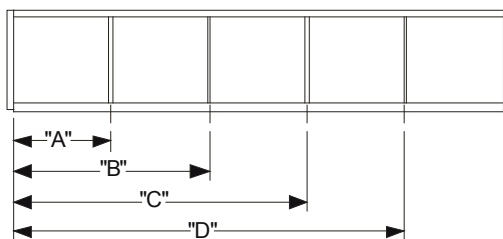

GRILLE BAR LOCATIONS, 5-PANE TRANSOM

UNIT SIZE	"A"	"B"	"C"	"D"
6/0	14-23/32"	29-11/32"	43-31/32"	58-19/32"
5/8	13-29/32"	27-3/4"	41-9/16"	55-25/64"
5/4	13-7/64"	26-9/64"	39-11/64"	52-13/64"
5/0	12-5/16"	24-35/64"	36-49/64"	49"

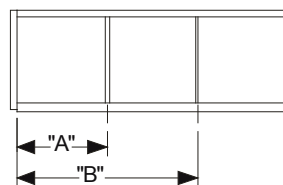

GRILLE BAR LOCATIONS, 3-PANE TRANSOM

UNIT SIZE	"A"	"B"
3/0	12-5/64"	24-3/64"

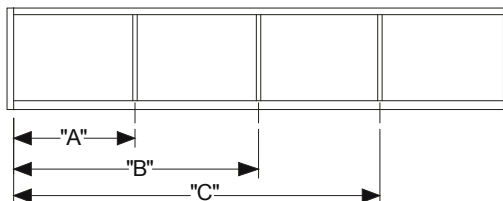

GRILLE BAR LOCATIONS, 4-PANE TRANSOM

UNIT SIZE	"A"	"B"	"C"
6/0	18-3/8"	36-21/32"	54-15/16"
5/8	17-3/8"	34-21/32"	51-15/16"
5/4	16-3/8"	32-21/32"	48-15/16"
5/0	15-3/8"	30-21/32"	45-15/16"

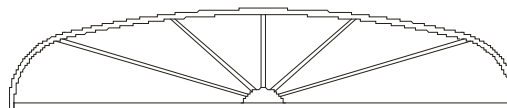

Removable/replaceable grille is standard in elliptical (clear) transoms and is factory installed.

Transom Installation Instructions

14 **INSTALL GRILLE BARS ON RECTANGULAR TRANSOMS.**

Plastic Slide and Nail Installation

Locate each grille to align nail of each plastic slide with mark.

Using the plastic slides, press attached nail at each end of grille firmly into sill and transom head.

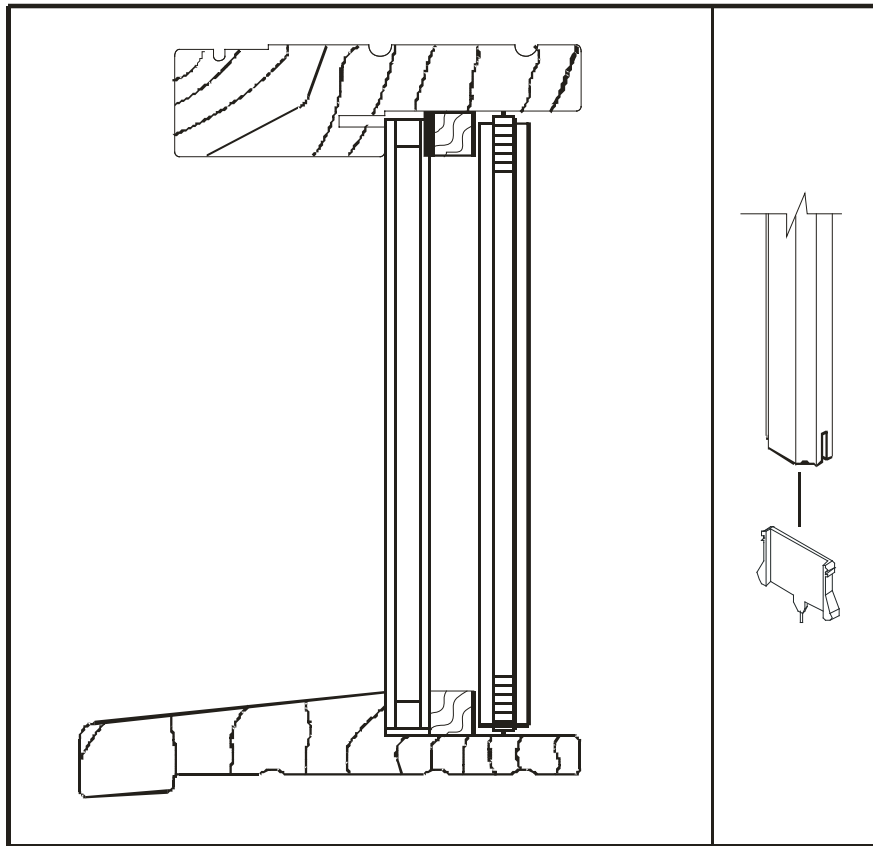

Warning : Modification or machining of this product can release wood dust, a substance know to the State of California to cause cancer.





Elliptical Transom Casing Installation Instructions



The curvature and fit of the casing may not appear to match the transom frame shape, if the two are compared before installation. Do not be concerned. The casing will flex and is fit to the frame at installation time.

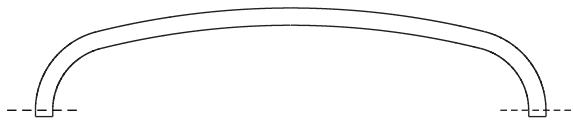

Complete installation of this elliptical casing before doing the straight vertical sides.

Casing is furnished with a small amount of extra length at each end. This will need to be trimmed at installation time.

1. TEMPORARILY ATTACH CASING

Before installing, mark casing for finish nail locations. Mark for outer and inner nails.

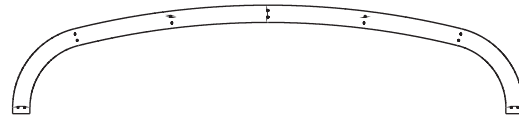

With transom installed in wall, place casing against transom frame. Position casing at center for desired reveal from frame edge. Tack in place at the top two center finish nail locations only. Do not drive nails fully. They will be pulled back out in Step 2.

Work from center out. Adjust casing so reveal margin is the same at each nailing point. Tack at each inner nail location.

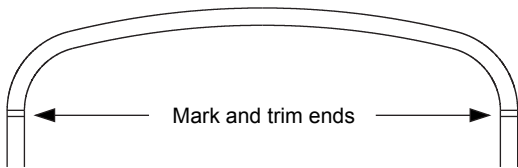
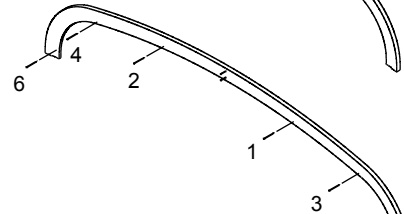
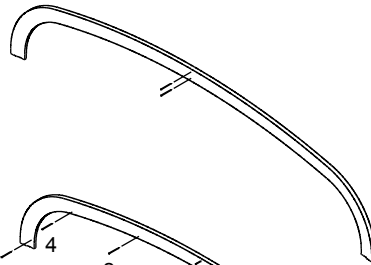

2. MARK AND TRIM ENDS

Attach ends of transom casing. Use square cut pieces of straight jamb casing and mark ends of elliptical casing for trim cuts.

Pull nails carefully. Remove casing from wall and trim ends.

3. REMOUNT CASING AND ATTACH PERMANENTLY

Work from center toward outside ends as in Step 1. Drive and set all nails.

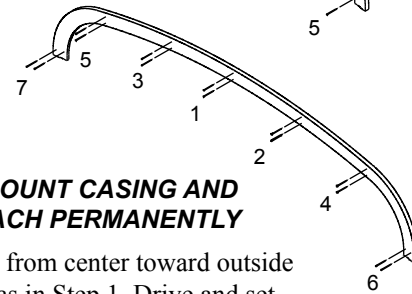

THERMA-TRU®
DOORS

Site Installation Instructions for Adjusta-Fit® 2

Read *all* instructions carefully before installing your new Therma-Tru Adjusta-Fit® 2 system.

Please note there are separate “Prehanging Instructions” to be reviewed and followed prior to completing the installation.

CODES

Building codes may vary from area to area. If a fire rating is required of the door and opening being framed, the installer must use installation materials and methods to satisfy the authority having jurisdiction. Therma-Tru provides labeled products, but bears no responsibility for installation.

Therma-Tru Positive Pressure (NFPA-252/UL-10C/CAN4-S104) Labeled Systems

This Therma-Tru door system has been labeled in compliance with NFPA-252/UL-10C/CAN4-S104 Positive Pressure Smoke and Draft control rating and requires a listed Category “H” gasket and the application of an additional Category “G” edge sealing system. To maintain the validity of this certification, the door installer must follow these instructions. They should be kept on file on the building premises for verification by the authority having jurisdiction.

- Verify that the frame is compatible with the door and properly installed.
- Install hardware per the hardware manufacturer's instructions.
- For Positive Pressure Rating, a listed and labeled category “G” edge seal shall be installed into the opening.
- For smoke rating, a listed and labeled category “H” Smoke and Draft control gasket (included) shall be installed into the opening.
- Installation must comply with requirements of NFPA 80 “Standard for Fire Doors and Fire Windows”.
- Surface mounted hardware must be attached with through bolts unless interior

THERMA-TRU®
DOORS

1750 Indian Wood Circle Maumee, Ohio 43537
1-800-THERMA-TRU (843-7628)
www.thermatru.com

© Copyright 2009 Therma-Tru Corp. All rights reserved. Therma-Tru Corp. is an operating company of Fortune Brands, Inc. All trademarks are property of their respective owners. 3/2009 Part # MSLCMFIST

Adjusta-Fit® 2
Parts List and Description

JOB SITE COMPONENTS

TRIM (3 Pieces)

Hinge, Lock and
Head Trim



SILL EXTENDER

(included in inswing package only)

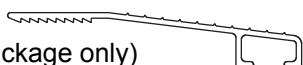

**FULL LIP STRIKE
CONVERTER PLATE**

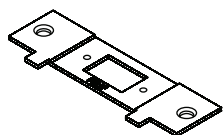

**DEADBOLT
LOCK PLATE**

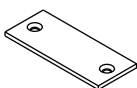

**DEADBOLT COVER
PLATE (door)**

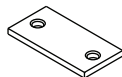

**(2) DEADBOLT
FILLER (door)**

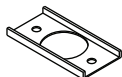

HARDWARE



(2) #8-32 x 3/8" Phillips
Undercut Flat Head
Type F Self-tapping
Machine Screw

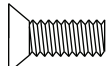

(2) #12-24 x 1/2" Phillips
Undercut Flat Head
Type A Machine Screw

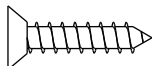

(2) #8 x 3/4" Phillips Flat Head Wood Screw

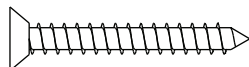

(2) #8 x 1 1/4" Phillips Flat Head Wood Screw

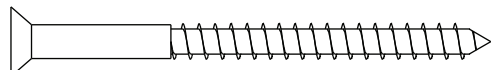

(6) #10 x 2 1/2" Phillips Flat Head Wood Screw

**(2) CORNER
SEAL PAD**

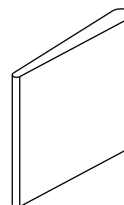

INSTALLATION INSTRUCTIONS

TOOLS REQUIRED

- Drill with #2 Phillips Driver Bit
- Shims
- Caulk Gun and Exterior Grade Sealant
- Utility knife or Scissors

PURCHASED SEPARATELY

- Category "G" Edge Seal
- Face attachment screws
- #8 x 1 1/4" flat head masonry screws for masonry installations

PAINTING FRAME AND DOOR

- DOOR PREP: Brush or sponge off dirt. Wipe dry.
- FRAME PREP: Wet-clean with mild abrasive cleaner. Rinse completely and wipe dry.
- Paint the door in an open position.
- Use a high quality exterior house paint to finish the frame and door when the temperature is above 50°F and humidity is below 90%.
- DO NOT paint weatherstrip. (It can be temporarily removed for painting.)
- DO NOT close door until the paint is completely dry.

**For information on where to purchase
Therma-Tru entry door systems,
call 1-800-THERMA-TRU (843-7628)
or visit www.thermatru.com**

Adjusta-Fit 2 Prehanging Instructions

1 CHECK ROUGH OPENING SIZE.

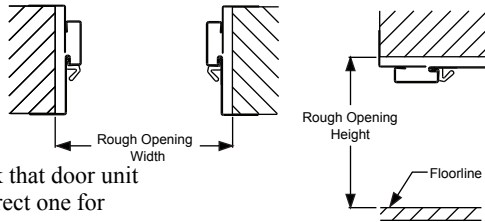

Check that door unit is correct one for opening.

Check rough opening width and height for the appropriate sill type. See table below.

If additional carpet clearance is required, the necessary full shim under the sill will change the rough opening height accordingly.

Door	Rough Opening Width	
	Standard	Undersize
2/0	25 1/16"	25"
2/4	29 1/16"	29"
2/6	31 1/16"	31"
2/8	33 1/16"	33"
2/10	35 1/16"	35"
3/0	37 1/16"	37"
3/6	43 1/16"	43"

Sill Type	Rough Opening Height			
	Standard		Undersize	
Inswing	6/8	7/0	6/8	7/0
Public Access	81"	85"	80 5/8"	84 5/8"
No Sill	80 1/2"	85 1/2"	80 1/8"	84 1/8"

2 CHECK ROUGH OPENING FOR ACCURACY.

WARNING: It is critical for proper fit and operation that the rough opening is correct

- Is subfloor level?
- Are walls plumb with jambs?
- Are studs or door bucks plumb?

3 UNITS WITH PUBLIC ACCESS SILLS, SEAL BOTTOM OF SILL

For public access sills, apply sealant along entire length of sill as shown.

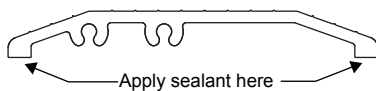

4 CENTER UNIT IN OPENING AND FASTEN FLANGES TO WALL.

Place unit on correct side of opening. Do not remove "L" bracket until door is in place, plumb and shimmed. Center unit in rough opening and set flanges flush and plumb against wall. Nail or screw flanges to wall through punched holes at perimeter.

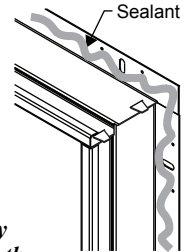

For jambs exposed to weather: apply sealant entire perimeter on underneath side of nailing flange.

5 LOCATE AND SECURE SHIMS BETWEEN WALL AND FRAME.

Keeping door closed, carefully shim between wall and frame. Shim hinge jamb behind hinges and the lock jamb as indicated in the figure below to plumb and level the door. Remove "L" bracket from door.

DO NOT allow shim force to twist frame. Insufficient shimming could cause jamb to bow at lock area allowing door to come open during a fire.

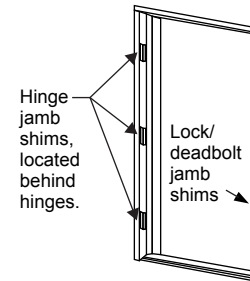

6 DRIVE SECURITY SCREWS INTO HINGE LEAVES.

With door open, at hinges where indicated, drill 7/64" diameter pilot holes and fasten #10 x 2 1/2" screws (provided) through holes in each hinge leaf.

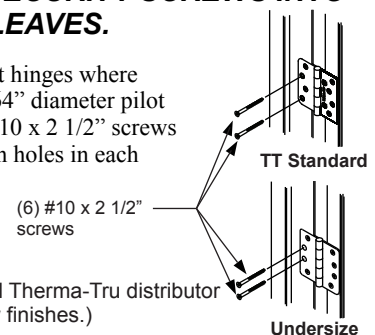

(Contact your local Therma-Tru distributor for alternate screw finishes.)

7 FASTEN LOCK JAMB TO WALL

Close the door and finish securing the face of the frame in the remaining holes.

8 FASTEN LOCK PLATES TO LOCK JAMB

Fasten converter plate with (2) #12-24 x 3/4" Phillips flat head machine screws and deadbolt plate with (2) #8-32 x 3/8" Phillips flat head Type F self-tapping machine screws provided.

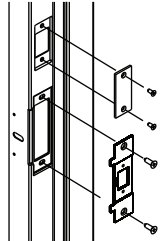

9 SEAL ALONG FRONT OF SILL BASE.

Prior to installing extender, apply a bead of sealant along front leg of riser.

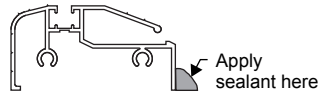

10 INSERT EXTENDER INTO RISER.

Seal feet of extender before sliding into base. Slide extender into sill base until it comes in contact with jamb stop.

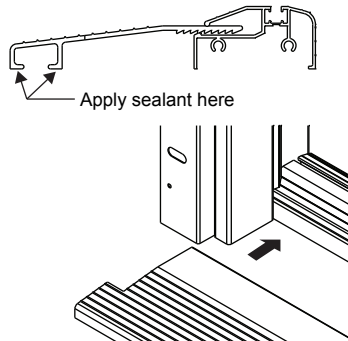

11 SLIDE TRIM ONTO JAMBS.

NOTE: If insulation is required between the frame and rough opening, insulate before sliding trim onto jamb.

Slide hinge and lock trim on first. Be sure that trim ends are resting on the sill or floor. Next apply head trim. Fasten to wall with nails or screws at hole locations.

For trim exposed to weather:
caulk entire perimeter on underneath side of nailing flange (refer to step 4 for illustration)

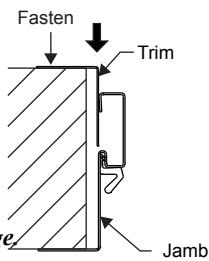

12 SEAL UNITS EXPOSED TO WEATHER.

Apply a bead of sealant at jamb/sill, trim/sill, jamb/trim and sill/floor joints.

Remove paper backing from self-adhesive corner seal pads and apply to jambs with the wide side pointing towards the weather-strip and bottom edge resting on the sill.

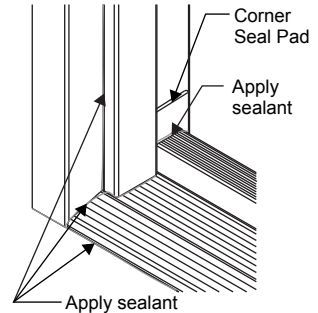

13 ANCHOR SILL TO FLOOR

Using #8 x 1 1/4" screws, provided, for wood frame installation, fasten aluminum extender to floor thru pre-fabricated holes.

When installing into masonry openings, use #8 flat head masonry screws following screw manufacturer's instructions.

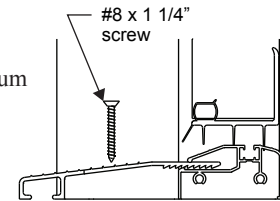

14 PAINT

See "PAINTING FRAME AND DOOR" on other side.

15 APPLY CATEGORY "G" EDGE SEAL (For Positive Pressure Rated System)

Cut head edge seal to fit between side (Weatherstrip removed from illustration for clarity.) jambs. Apply to head jamb locating it under and against weatherstrip. Measure and cut side edge seal to fit between head and sill. Cut to fit between hinges and strikes. Locate and apply to jambs as shown.

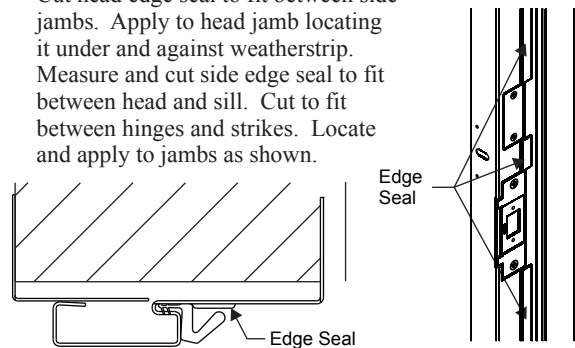

Fiber-Classic/Smooth-Star Corner Seal Pad Instructions

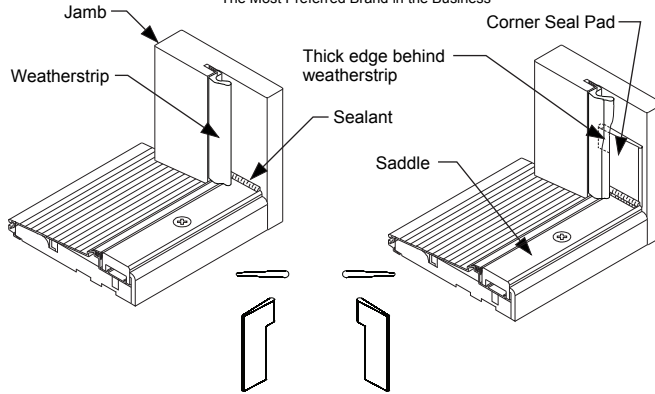

1. When saddle is adjustable, adjust saddle to desired height to ensure proper seal and door function.
2. Place a 1/4" bead of sealant at corners where saddle meets side jambs.

3. Remove paper backing from corner seal pad and position pad tight to the saddle and centered on the saddle. Tuck top of pad to the back of weatherstrip.

Note: If further adjustment is required, the following steps must be repeated on both jamb sides to prevent air, light and water infiltration.

PART #: TDSILLINST REV. A

Classic-Classic Corner Seal Pad Instructions

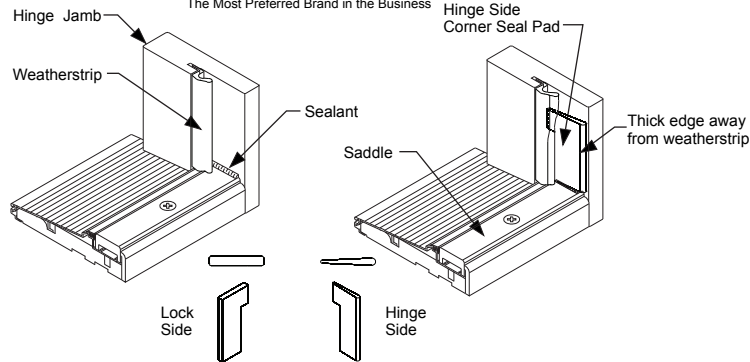

1. When saddle is adjustable, adjust saddle to desired height to ensure proper seal and door function.
2. Place a 1/4" bead of sealant at corners where saddle meets side jambs.

3. Remove paper backing from corner seal pad and position pad tight to the saddle and centered on the saddle. Tuck top of pad to the back of weatherstrip.

Note: Use correct corner pad for either lock or hinge side as shown above. If further adjustment of the saddle is required, the following steps must be repeated on both jamb sides to prevent air, light and water infiltration.

PART #: TDSILLINST REV. A

THERMA TRU
The Most Preferred Brand in the Business
Corner Seal Pad Instructions
Basic Fixed Sills

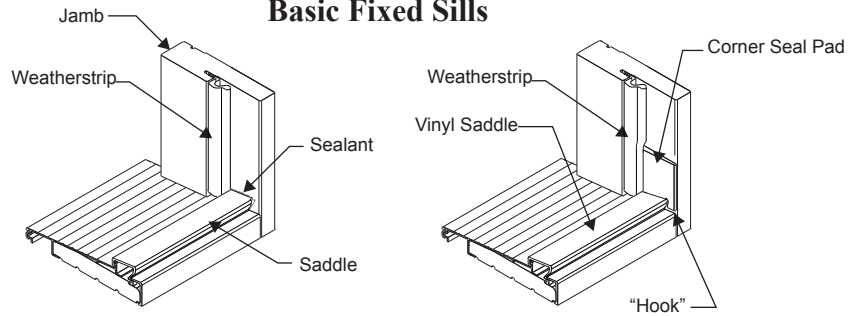

1. Place a 1/4" bead of (Elastomeric and Polyurethane) sealant at corners where saddle meets side jambs.

2. Remove paper backing from corner seal pad and position pad tight to the saddle, tucking behind weatherstrip and in line with edge of jamb. Place "hook" over inside edge as shown.

NOTE: Corner seal pads are handed.

MSCPSA

Adjustable Sill Cover Instructions

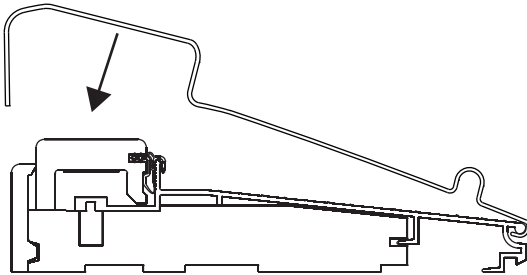

1. Position cover and hook onto sill.

NOTE: Be sure to remove sill cover before any type of floor covering is installed

Grille Installation Instructions

Grilles come complete with clips.

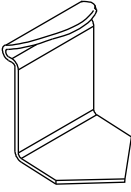
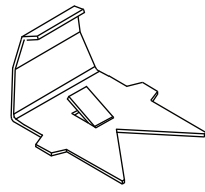
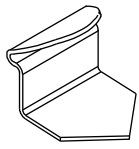
FRAMED	FLUSH GLAZED	CC
		
Part # RPWGM2	Part # RPFGGC	Part # RPCGC

SPRING STEEL CLIPS

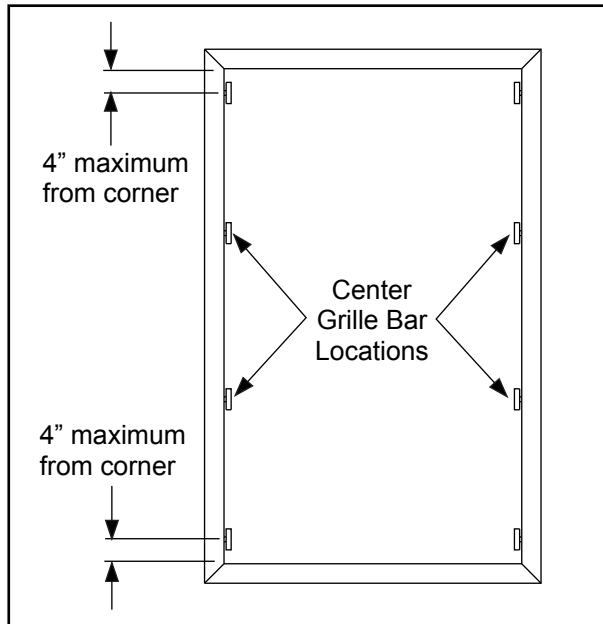

FRAMED LITES

Position Clips

Locate clips on vertical sides of frames
4" maximum from each corner and at
center grille bar locations.

Installation for Lite Frames

Install Clips

Loosen doorlite screws slightly.

Slide flat side of clips under
interior side of doorlite frame.

Retighten screws.

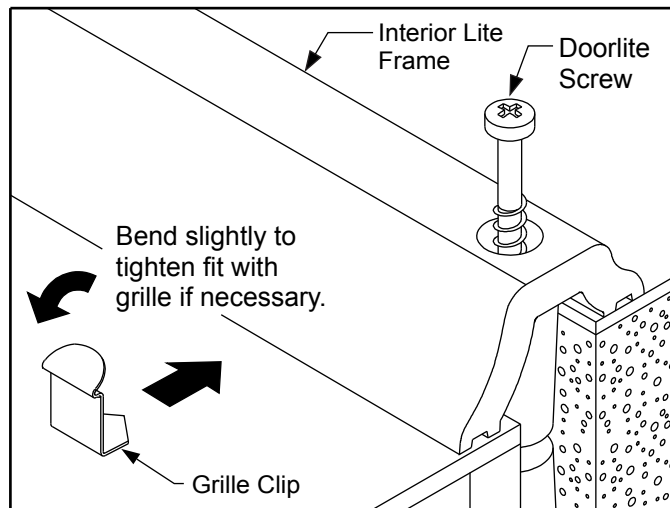

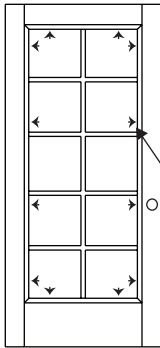

Installation for FC & SS Flush-Glazed Doors

To assure proper installation, carefully remove any excess sealant at glass edge before installing grille clips.

Insert steel spring clips between stop and glass at the locations shown. **AVOID PUTTING CLIPS IN LINE WITH MUNTINS HORIZONTAL AND VERTICAL GRILLE BARS.** (Note: number of clips may vary from shown due to grille size and door style.)

Use the installation tool as shown to push the clip completely into the locked position.

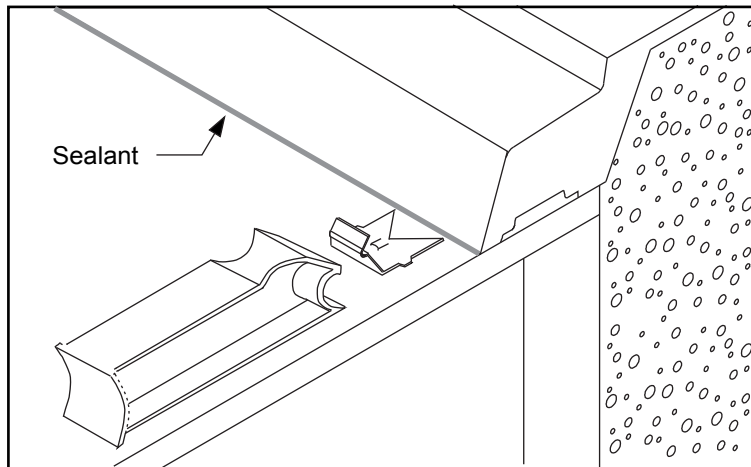

Section Cut for Clarity

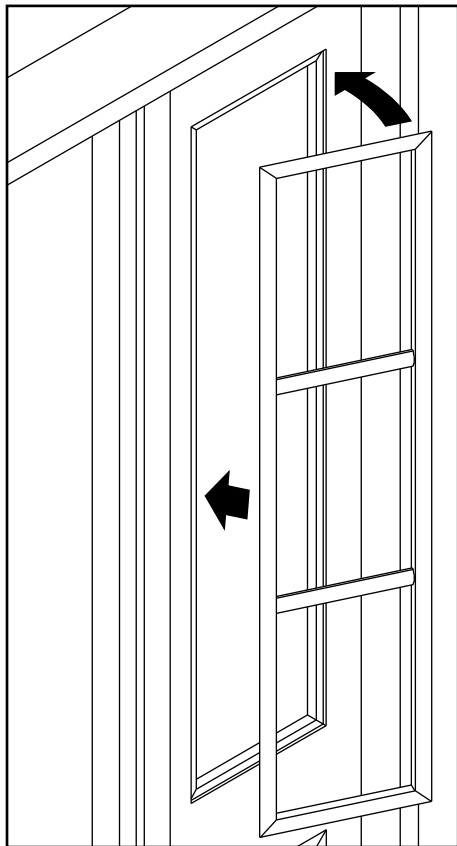

With all the clips installed, insert grille against clips on one side. Gently push opposite side of grille against glass, locking all clips into frame. Remember to gently press the top and bottom of the grille against the glass.

Clips will be hidden when grille is inserted.

To remove, gently pull away from the glass surface at one long side of the grille where the muntins meet the grille frame.

Grille Installation Instructions

Installation for Flush-Glazed Classic-Craft®

Locate grille clips under molding edges where molding meets glass.

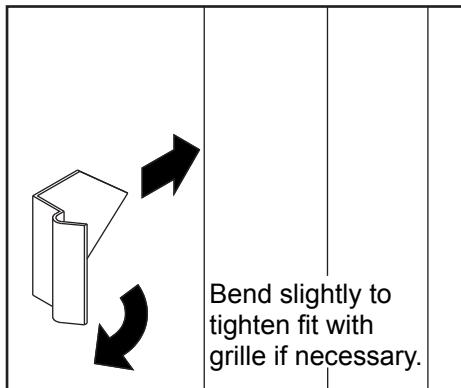
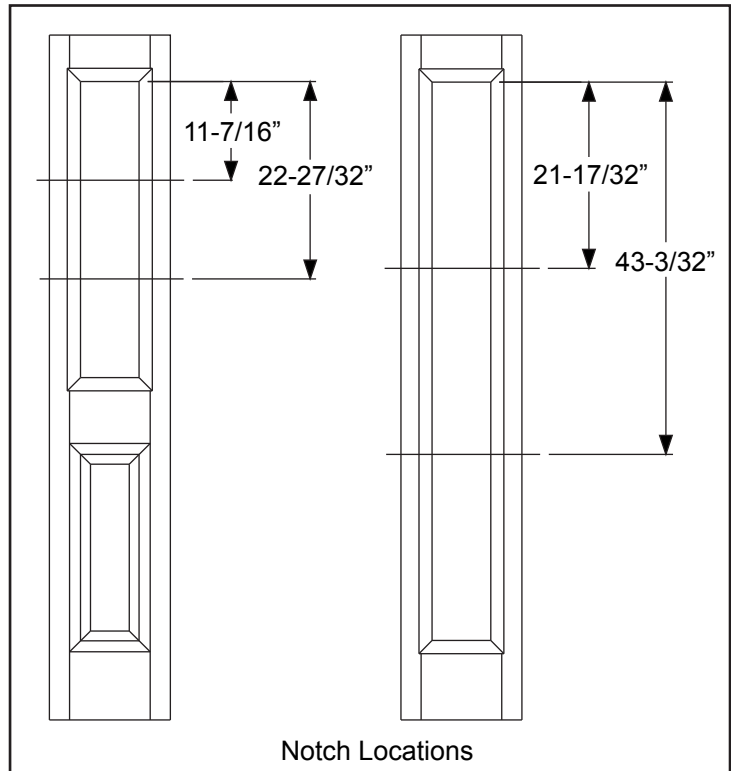

Insert grille clips by sliding in spade edge of clip under molding and press clip all the way in.

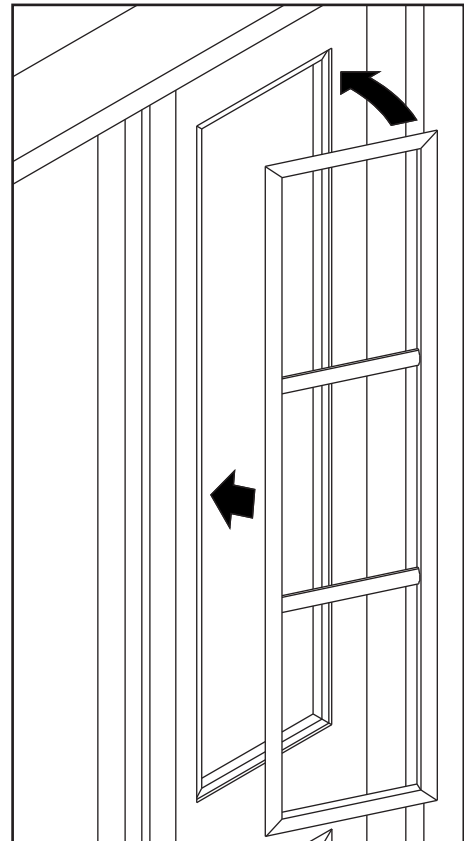

Insert grille into door, placing one long side against hardware.

Snap into place along all other sides.

NOTE: TEMPERATURE RANGE FOR OPTIMUM TAPE ADHESION IS 70° TO 100°F. MINIMUM APPLICATION TEMPERATURE IS 60°F. BOTH THE DOOR AND LITE DIVIDER ARE TO BE IN THIS TEMPERATURE RANGE. ADHESIVE IS NOT REPOSITIONABLE.

Materials Needed:

- 70% Isopropyl Alcohol or adhesion promoting solution
- Clean rags
- ½" Masking tape
- J-Roller
- Shim stock or business card
- Pencil
- Plastic zip ties or coffee stirrers
- Sanding materials

When installing over GBG's only use bronze flat bar patterns

SDL Preparation for Interlocking Bar Patterns:

1. Starting at the external glass side, take a horizontal divider and place it at the top of the glass. Center the bar in the opening and use the notch(es) on the divider to mark on the frame the top position of the vertical divider(s). Slide the bar to the bottom of the glass and repeat for the bottom position of the vertical dividers.
2. Take a vertical divider and center between the frame markings. Mark amount of bar to trim (if necessary). There should be 0.015" - 0.020" clearance (use a business card as a shim) on each side to allow for expansion or contraction. Repeat for each vertical divider. Be sure to mark each divider with its location (left/right).
3. Trim bars at appropriate angle (see below) to their correct size. Trimming may be done with a stationary belt sander, disc sander, or sanding block.

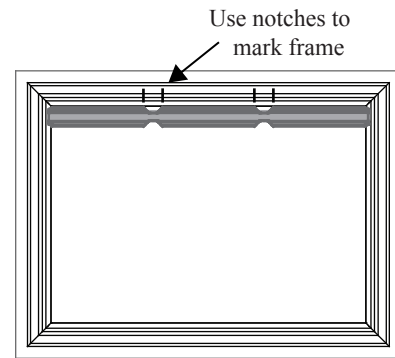

Framed Lites
(7x64, 21x15, 22x47, 22x64)



Framed Lites
(8x36, 8x47, 20x64, 22x36)

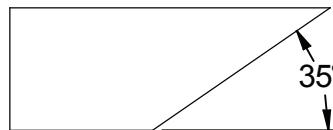

Flush Glazed
(all sizes)



4. Place a trimmed vertical bar to one side of the glass and use the notches on the dividers to mark on the frame the position of the horizontal dividers. Repeat on the other side of the glass.
5. Assemble the vertical and horizontal bars together and center the bars on the glass at the frame markings without removing the carrier backing tape. Mark amount of bar to trim (if necessary). There should be 0.015" - 0.020" clearance on each side. Repeat for each horizontal divider. Be sure to mark each divider with its location (top, bottom, center, etc).
6. Disassemble bars. Trim bars at appropriate angle to their correct size.

SDL Bar Installation Instructions (Smooth Star / Fiber Classic)

- Assemble the horizontal and vertical divider(s). Use masking tape to secure the divider bars together at the joints. Peel off the Carrier Backing from all of the divider pieces. Clean any trimming residue from tape using 70% Isopropyl Alcohol. Lightly place the tips of small zip ties or coffee stirrers roughly 1/8" onto the adhesive backs as shown. For each of the divider bars, position 1 tie at each end of the divider and each joint, and 1-2 ties in the middle. The ties will keep the adhesive backing off of the glass during final positioning.

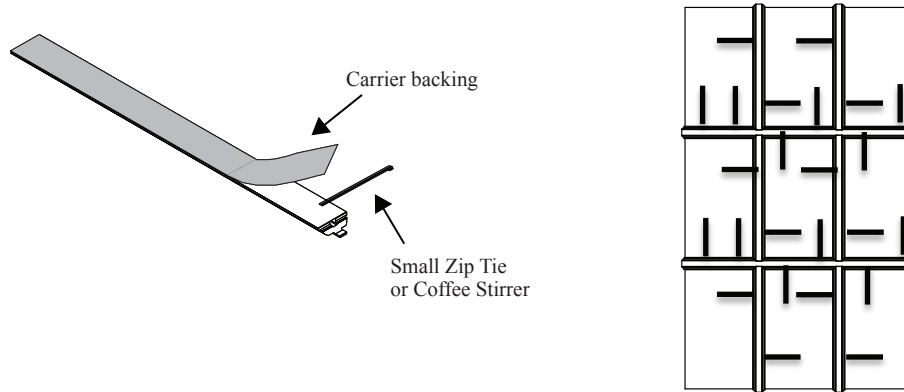

Glass Preparation:

Moisten a clean cloth with 70% Isopropyl Alcohol or use an adhesion promoting solution. Wipe the glass before attaching dividers. Allow to dry.

**FAILURE TO PREPARE THE GLASS PROPERLY WILL RESULT IN POOR TAPE ADHESION.
DO NOT USE A GLASS CLEANER TO PERPARE THE GLASS AS THIS WILL PREVENT PROPER ADHESION.**

SDL Installation:

- Position the divider grid back onto the glass using the frame position marks. Check to ensure that, for all of the frame to divider points, there is a 0.015" - 0.020" gap between the divider and the frame. Once in position, press down at all of the ends opposite the zip tie to lock the position, and then pull out that zip tie. Once all of the divider ends are attached, pull out the middle zip ties from the dividers. Using a J-Roller, roll firmly along the entire length of the horizontal and vertical dividers. Look through the interior side to confirm all dividers adhere to the glass, particularly around the perimeter and divider joints. Once attached, remove the masking tape.
- Repeat steps for interior frame side.

SDL Preparation for Non-Interlocking Bar Patterns:

1. Make template to the dimensions required for your lite pattern (see subsequent pages).
2. Beginning with the exterior, position each divider using the proper template and mark position on the frame. Center bar in opening. Mark amount of bar to be trimmed (if necessary). There should be 0.015" - 0.020" clearance (use a business card as a shim) on each side to allow for expansion or contraction. Repeat for each divider. Be sure to mark each divider with its location (top, middle, bottom, etc).
3. Trim bars at appropriate angle (see below) to their correct size. Trimming may be done with a stationary belt sander, disc sander, or sanding block.

Framed Lites
(7x64, 21x15, 22x47, 22x64)

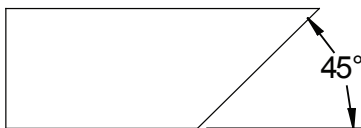

Framed Lites
(8x36, 8x47, 20x64, 22x36)

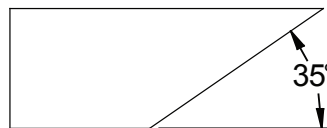

Flush Glazed
(all sizes)

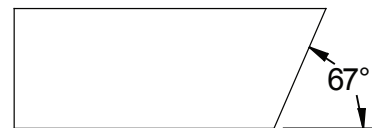

Glass Preparation:

Moisten a clean cloth with 70% Isopropyl Alcohol or use an adhesion promoting solution. Wipe the glass before attaching dividers. Allow to dry.

**FAILURE TO PREPARE THE GLASS PROPERLY WILL RESULT IN POOR TAPE ADHESION.
DO NOT USE A GLASS CLEANER TO PERPARE THE GLASS AS THIS WILL PREVENT PROPER ADHESION.**

SDL Installation:

1. Peel off the Carrier Backing from all of the divider pieces. Clean any trimming residue from tape using 70% Isopropyl Alcohol. Lightly place the tips of small zip ties or coffee stirrers roughly 1/8" onto the adhesive backs as shown. For each of the divider bars, position 1 tie at each end of the divider and 1-2 ties in the middle. The ties will keep the adhesive backing off of the glass during final positioning.

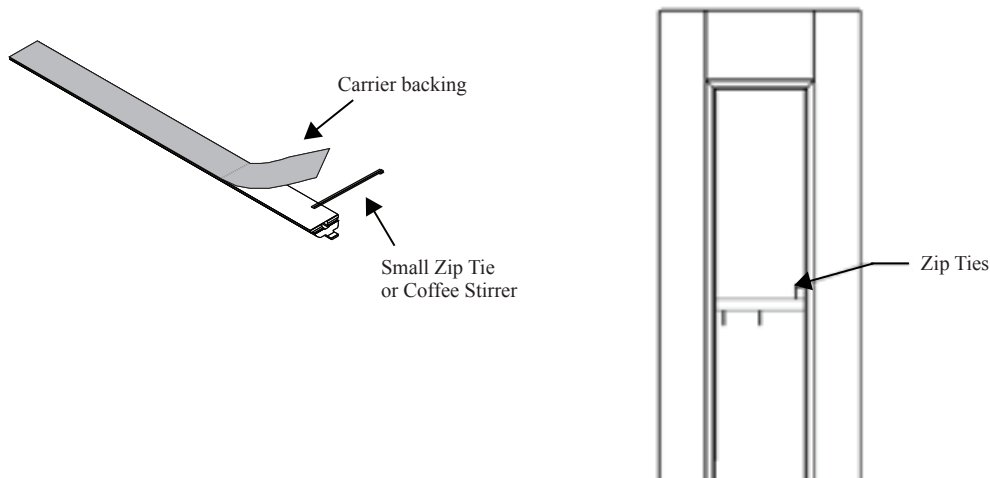

2. Position the dividers back onto the glass using the frame marks. Check that the dividers cover the internal GBGs (if present). Press down on each end of the divider to lock the position and remove the zip tie. Repeat for the other end. Remove the remaining zip tie(s). Using a J-Roller, roll firmly along the entire length of the dividers. Look through the interior side to confirm all dividers adhere to the glass, particularly around the perimeter.
3. Repeat steps for the interior dividers. Check the alignment of the interior dividers with the exterior dividers before attaching interior dividers.

SDL Bar Installation Instructions (Smooth Star / Fiber Classic)

21 X 15
2 LITE CRAFTSMAN

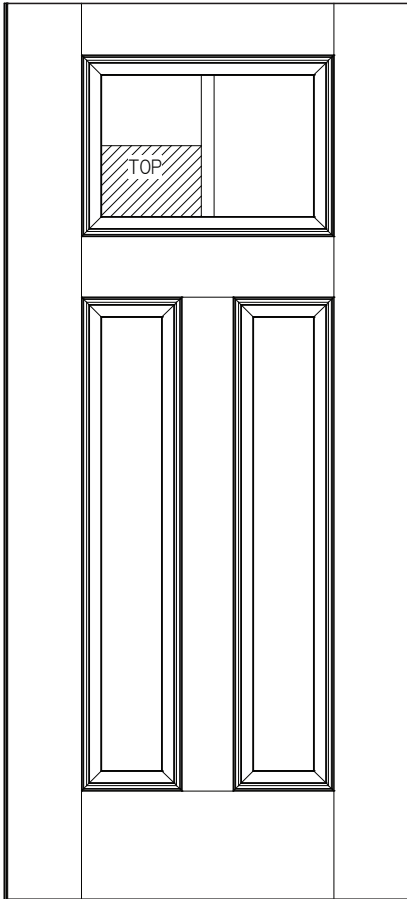
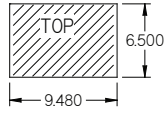

21 X 15
3 LITE CRAFTSMAN

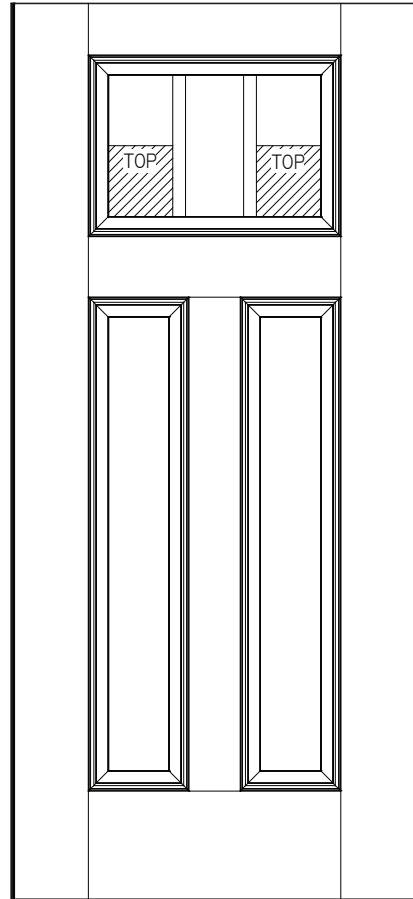
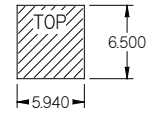

7 x 64
1 - Lite Craftsman

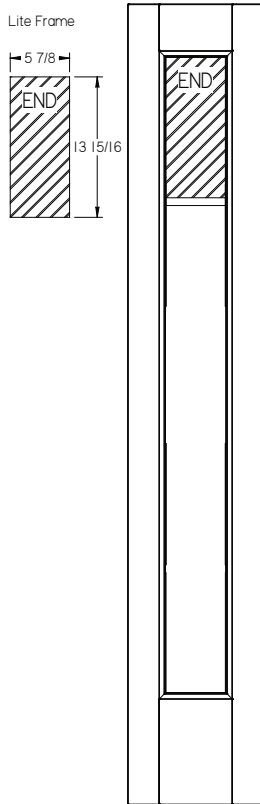

7 x 64
5 - Lite

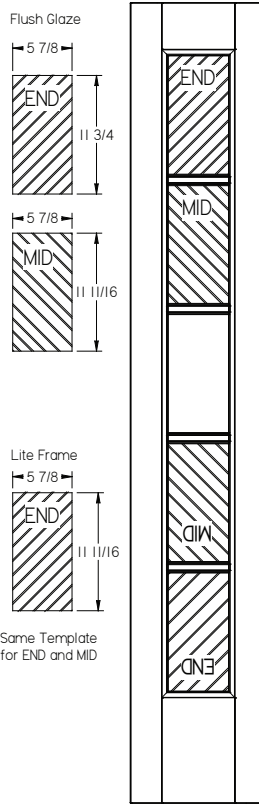

8 x 64
5 - Lite

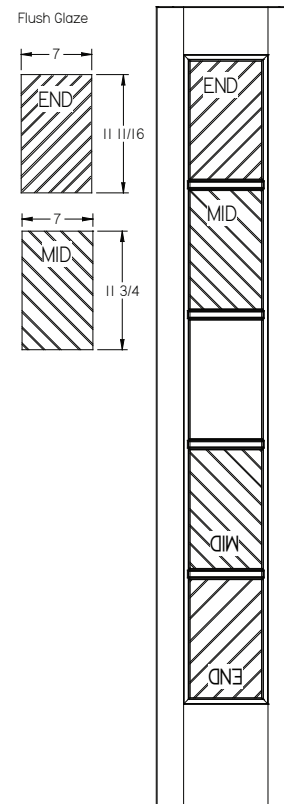

8 x 47
4 - Lite

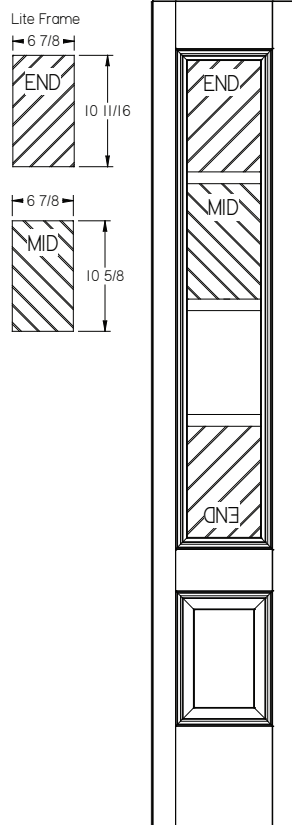

8 x 36
3 - Lite

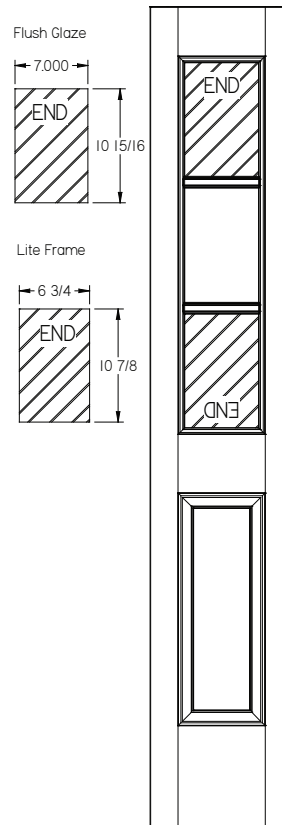

Spring Hinge Instructions

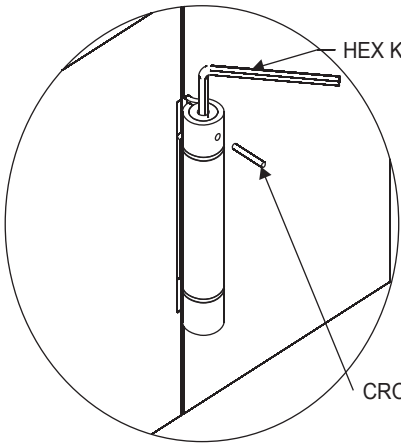

INSTRUCTIONS FOR THERMA-TRU ADJUSTABLE TENSION SPRING HINGE

Installation:
First mount the hinges by matching the hinge leaf (with the Therma-Tru logo) to the door, then match the other leaf (with the "UL" logo) to the jamb. Doing this may require having adjustment end down, depending on handing.

1. Place door in closed position. Insert allen wrench in hex adjustment hole as shown in left diagram.
2. If adjustment end is up, turn hex key clockwise to desired spring tension.
If adjustment end is down, turn key counterclockwise to desired spring tension. Observe caution notes.
3. Insert cross pin when holes in center stud and hinge knuckle line up. Slowly release pressure on the hex key.
4. Remove hex key and test closing action of door.
5. Repeat steps 1-4, if necessary, to increase spring tension.

To make tension adjustment tamperproof, snip off cross pin at break-away head. Do not remove head if future adjustment may be needed.

- Use 3-1/2" spring hinge for 1-3/8" thick doors, maximum 2'8" wide X 7' high.
- Use 4" or 4-1/2" spring hinge for 1-3/4" thick doors, maximum 3' wide X 7' high
- Doors over 5' high require three hinges. At least two of the three must be spring hinges.
- The maximum door size and number of spring hinges required are based on limits set forth in NFPA 80. For maximum versatility, use all spring hinges.

NOTE:
Adjust spring hinge to minimum tension required to close and latch the door. Overtensioning will reduce the spring life.

Caution: Do not exceed three holes of tension for doors opening 180 degrees. Do not exceed four holes of tension for doors opening 90 degrees.

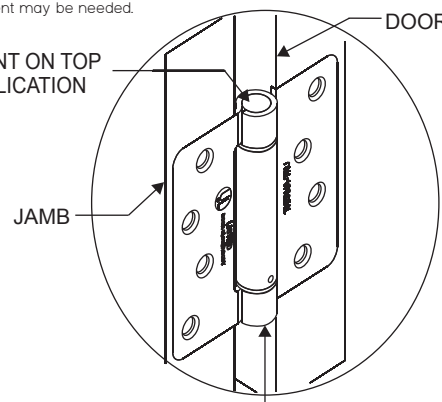

THERMA-TRU “Wide Profile” Screen Installation - Hinged Patio

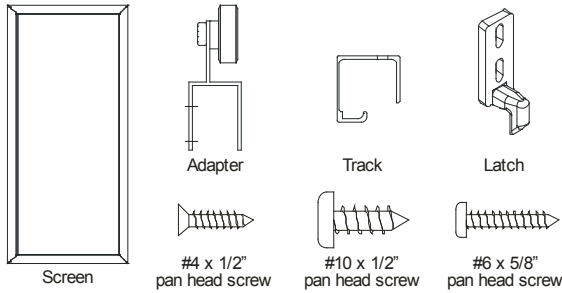

1 Remove existing screen track.

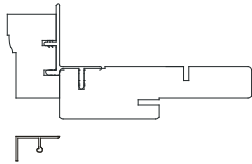

2 Insert wheels of top hung adapter into top hung track as shown.

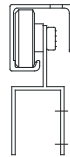

3 Position track up into screen channel. Drill 1/16 inch pilot holes thru holes in track into head jamb approximately 1/4 inch deep.

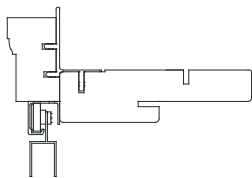

4 Fasten track to head jamb with #4 x 1/2 inch flat head screws.



5 Insert screen into adapter channel and rotate down engaging wheels in bottom of screen with track on sill.

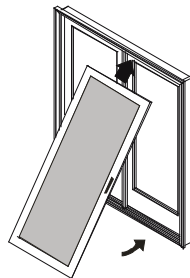

6 Align adapter with edge of screen.



7 Drill 1/8 inch holes thru hole locations in adapter into screen from interior of unit. Fasten with #10 x 1/2 inch screws.

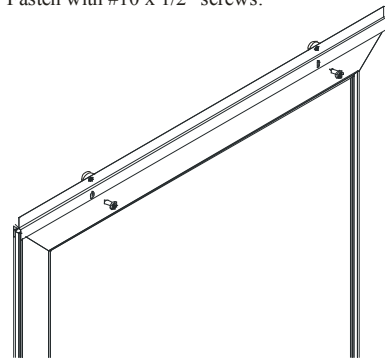

8 Close screen door and locate position of latch. Mark hole locations for latch. Drill 1/16 inch pilot holes into side jamb. Fasten with (2) #6 x 5/8 inch pan head screws.

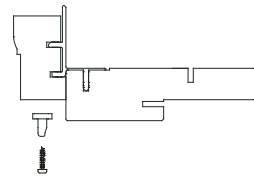

1750 Indian Wood Circle Maumee, OH 43537
1-800-THERMATRU (843-7628)
www.thermatru.com

© 2005 Therma-Tru Corp.
Therma-Tru Doors is an operating company of Fortune Brands, Inc. 4/1/05
Part # THSINSTALL

Screen Installation

THERMA TRU® “Wide Profile” Screen Installation - Sliding Patio

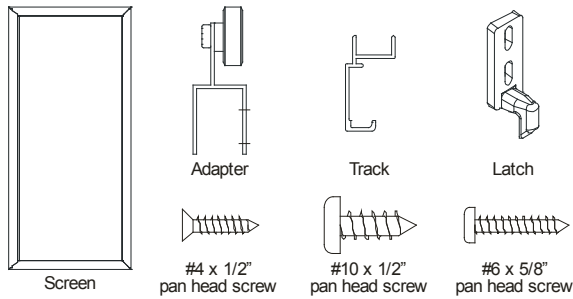

1 Remove existing screen track by rotating the back edge down as you pry it out.

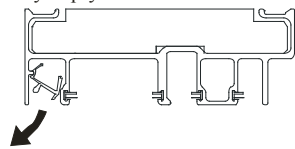

2 Insert wheels of top hung adapter into top hung track as shown.

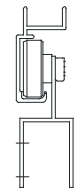

3 Position track up into screen channel. Drill 1/16” pilot holes or punch with an awl, thru holes in track into head jamb approximately 1/4” deep.

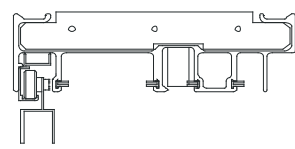

4 Fasten track to head jamb with #4 x 1/2” flat head screws.

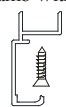

5 Insert screen into adapter channel and rotate down engaging wheels in bottom of screen with track on sill.

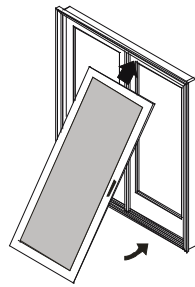

6 Align adapter with edge of screen.

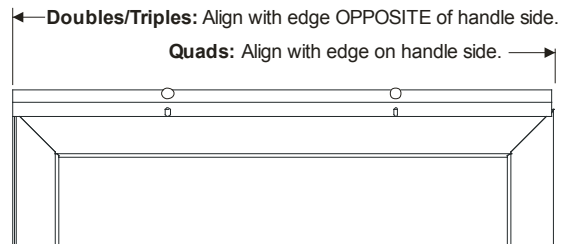

7 Drill 1/8” holes thru hole locations in adapter into screen from exterior of unit. Fasten with #10 x 1/2” screws.

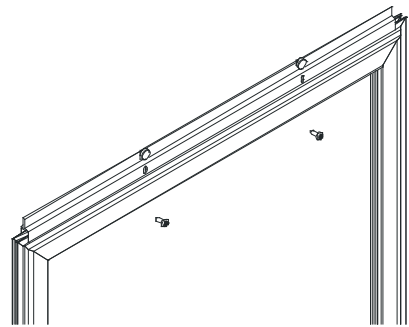

8 Close screen door and locate position of latch on side jamb. Mark hole locations for latch. Drill 1/16” pilot holes. Fasten with (2) #6 x 5/8” pan head screws.

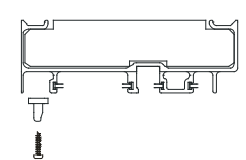

9 Quad Systems Only

Position screen astragal on passive screen so it does not interfere with head and sill tracks. Pre-drill (4) equally spaced 1/8” pilot holes. Fasten astragal to screen with (4) #8 x 1” pan head screws.

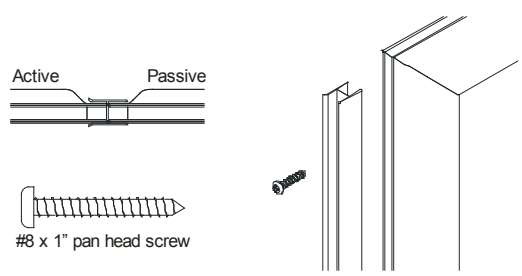

THERMATRU

French Door Hinged Screen Installation

French Door Hinged Screen Materials Supplied

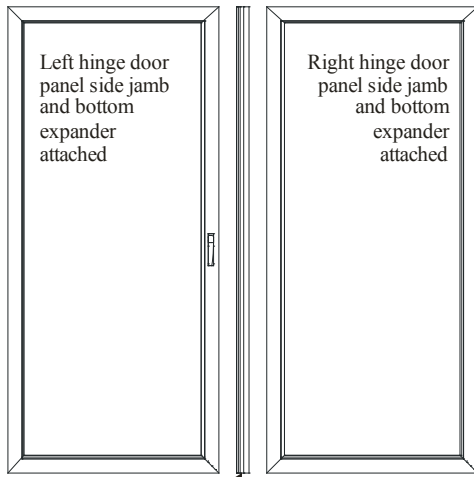

- Head Channel
- Door Handle Package
- Spring Latch (2)
- 20 - 1" Stainless Steel Screws
- 4 - 3/4" Stainless Steel Screws

1 Place head channel at the top of the door opening on the exterior side, centering it between the right and left side jambs. Using a 1/8" drill bit, pre-drill a hole in the head brickmould using the pre-punched holes in the aluminum channel as a guide. Fasten head channel to head brickmould using #8 x 1" stainless steel screws.

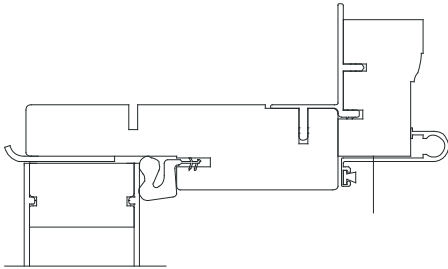

THERMATRU

1750 Indian Wood Circle Maumee, OH 43537
1-800-THERMATRU (843-7628)
www.thermatru.com

© 2005 Therma-Tru Corp.
Therma-Tru Doors is an operating company of Fortune Brands, Inc.
Part # DDSINSTALL

1/1/05

2 Position the right or left door panel into the frame. Be sure the side hinged channel aligns properly with the head jamb miter. Using a 1/8" drill bit, pre-drill a hole into the side brickmould using the pre-punched hole in the aluminum channel as a guide. Fasten side jamb channel to side brickmould using #8 x 1" stainless steel screws and check for proper alignment. Repeat for remaining door panel.

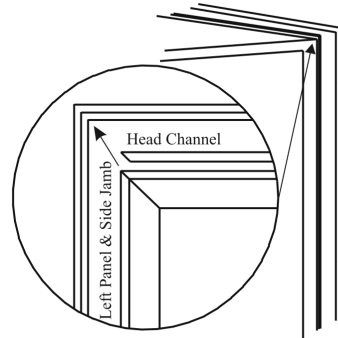

3 Trim the black rubber door sweep even with the adjustable bottom expander. Crimp the ends of the slot with pliers to prevent the sweep from sliding out.

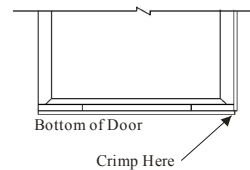

4 Install the handle hardware on the active door .

CAUTION: BE SURE TO POSITION THE SCREEN DOOR HANDLE SO THAT IT DOES NOT INTERFERE WITH THE OPERATION OF THE HANDLE SET ON THE PRIMARY DOOR.

At desired height, fold self-adhesive template to door.

Mark center of the three holes on both sides

Using a 5/16" drill bit, bore the three holes 1/2 way through on both sides.

Note: Ream out center hole by inserting drill and rotating with a slight wobbling action to clear hole and allow complete freedom of action for spindle.

SPINDLE MUST BE FREE.

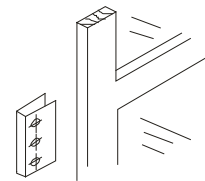

Screen Installation

THERMA TRU

French Door Hinged Screen Installation

5 Assemble outside handle with button, spindle and spring. Push this assembly through installation holes from outside of door as shown.

Depress button to extend spindle. Position latch mechanism over holes on inside of door, guiding spindle into rectangular slot in center of mechanism. Insert (2) machine screws into threaded sleeves and screw each down to snug position.

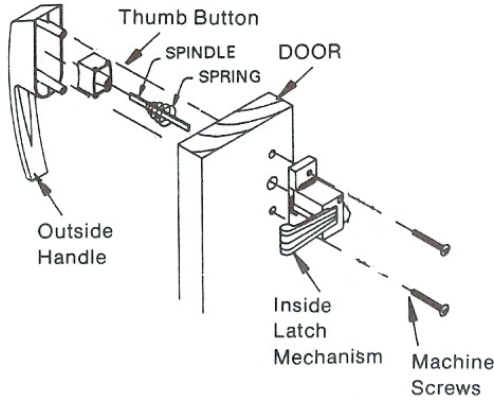

7 Install the spring latches to the passive door at the head using the spacer and screws provided. Base of the latch should be 1/4" down from the head channel.

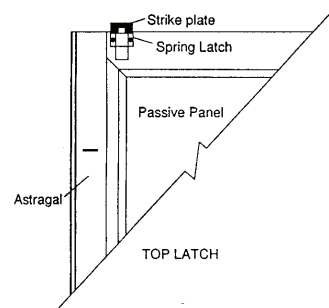

8 Close both panels and recheck for proper clearance between astragal and active panel (1/8"). Check for proper latch engagement. Secure the astragal to the passive panel by pre-drilling 4 holes with a 1/8" drill bit and using 4-3/4" screws. Adjust the bottom expander to the desired position.

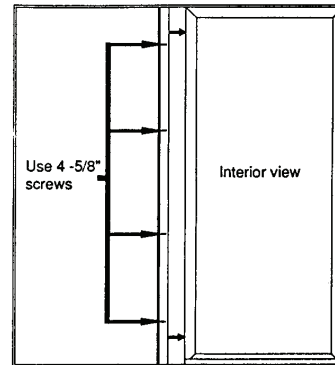

6 Place the astragal on the passive panel (See Inset) allowing an 1/8" gap. Top of astragal should be even with top of door. Fasten through the center of the slot. Close active panel and adjust astragal for even gap.

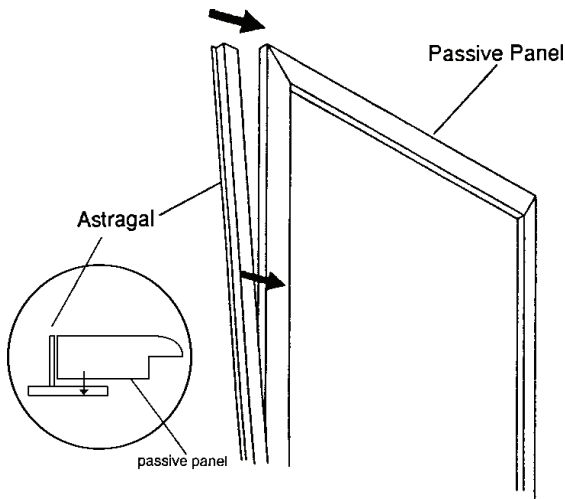

9 Position the remaining spring latch to expander and the strike plate (lip to the outside) to sill. Once proper location has been determined so that the door is aligned with frame, fasten with enclosed screws.

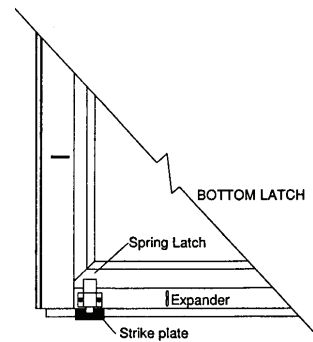

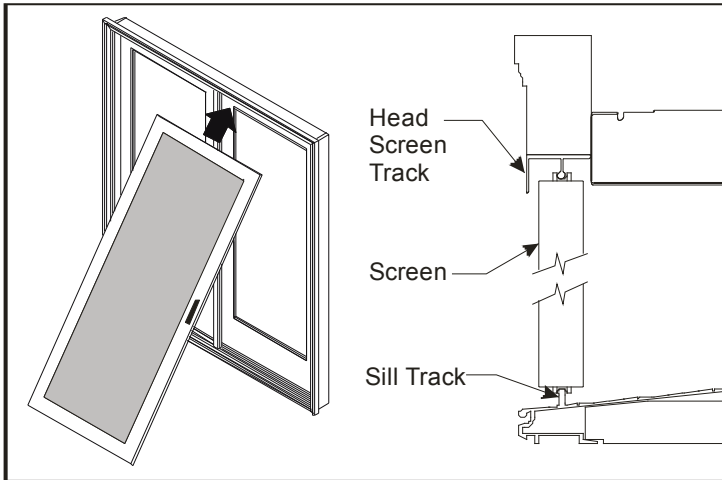

Install Screen Door

Install screen door by inserting top guide wheels on head track.

Lift bottom wheels up and engage with lower sill track.

Screen Installation

Venting Sidelite Screen Materials Supplied

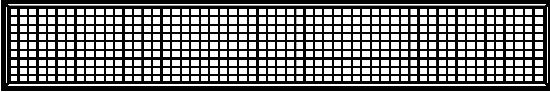

Screen

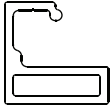

Side Screen tracks (2)

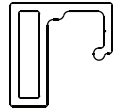

Top Screen Track



#6 x 3/4"
PFH Screws

1 Install Top Screen Track

Remove weatherstrip prior to installation.

From the interior, position top screen track 1/2" back from the head jamb stop, making sure to center between the side jamb and the mullion.

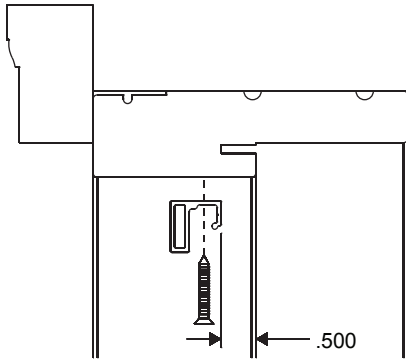

Using a 3/32" drill bit, drill two holes approximately 3/4" deep into the head jamb using the pre-punched holes in the top screen track as a guide.

Fasten top screen track to head jamb using two #6 x 3/4" screws.

2 Install Side Screen Tracks

Assemble the left and right screen tracks following the same steps as installing the head screen track, positioning as shown below.

Make sure to position flush with the top screen track, and that both sides are completely straight.

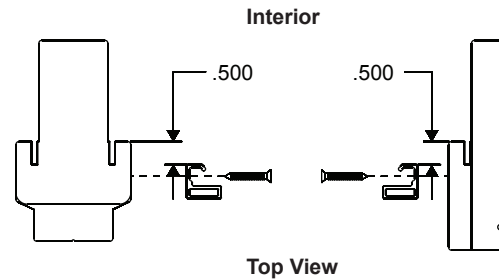

3 Install Screen

Note: Make sure that all thumb clips are pulled in before installing the screen.

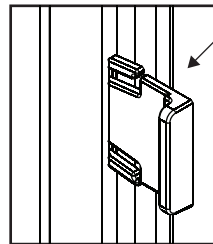

Interior

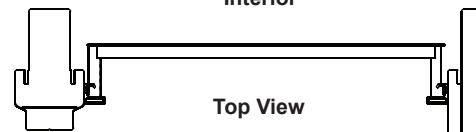

Starting at the bottom, insert the screen then roll in towards the top. Gently yet firmly press screen into place. Push the thumb clips back in until they snap back into the screen track.

Re-insert weatherstrip.