



**ARCHITECTURAL
AUTHENTICITY
WITH UNPARALLELED
PERFORMANCE.**

CONTENTS

Innovation & Performance	2-3
Design	4-5
Window & Door Types	7
Exteriors & Interiors	8-9
Window Hardware	11
Patio Door Hardware	12-13
Glass	14-15
Art Glass & Insect Screens	16-17
Grilles	19
Easy Connect Joining System	20

A-SERIES WINDOWS

Windows	21
Casement Windows	26
Awning Windows	32
Double-Hung Windows	38
Picture Windows	44
Transom Windows	52
Specialty Windows	67
Complementary Casement Windows	113

A-SERIES PATIO DOORS

Patio Doors	119
Gliding Patio Doors	126
Hinged Inswing Patio Doors	134
Hinged Outswing Patio Doors	150
Patio Door Sidelights & Transoms	156
Complementary Curved Top Patio Doors	177

Exterior Trim	189
---------------------	-----

Combination Designs	196
Product Performance	206
Installation Accessories & Information	226
Sustainability	228

For warranty information, visit andersenwindows.com/warranty.



Andersen Corporation, including its subsidiaries, has been named a 2022 ENERGY STAR® Partner of the Year – Sustained Excellence Award winner, the highest honor given by ENERGY STAR, for continued leadership in protecting the environment through superior energy efficiency achievements.



"ENERGY STAR" is a registered trademark of the U.S. Environmental Protection Agency.



AMERICA'S MOST LOVED BRAND OF WINDOWS & DOORS.*

You want to give your customers a home they love, and we're here to make that easy for you. That's why we're proud to offer you products that rate #1 in quality and performance,** and to be the #1 trusted and recommended window and door brand:

A-SERIES PRODUCTS

Designed in collaboration with architects, A-Series products are our most fine-tuned windows and doors. Their matching sight lines, matching glass setbacks and size options will help you bring any architectural style to life down to the smallest detail. And with numerous glass options and composite exteriors, they're our best performing and most energy-efficient products capable of withstanding the toughest conditions.

*2022 Andersen brand surveys of U.S. realtors, contractors, builders and homeowners.

**2022 Andersen brand surveys of U.S. contractors, builders and architects.

UNPARALLELED INNOVATION & PERFORMANCE

The beauty of A-Series products goes beyond their architecturally detailed designs. They're also the best-performing, most energy-efficient windows and patio doors we've ever engineered. With environmental and impact certifications,* they can help you achieve almost anything.

BUILT STRONG

We use solid wood in interior door panels and window sash and frames plus fiberglass on outer door frames and window sash exteriors to provide an unmatched combination of strength, insulation, versatility and beauty.

Additionally, our Fibrex® composite material used in window frames and trim components delivers twice the strength and rigidity of vinyl.



WATER MANAGEMENT THAT WORKS

These features work together to direct water away from buildings:

- Hermetically sealed corner keys keep frames tight
- Sloped sill on double-hung windows
- Sill on patio doors channels water away from the home
- Innovative trim attachment flange secures trim independent of the window or door's water management system

VIRTUALLY MAINTENANCE-FREE EXTERIORS

Exteriors of A-Series products never need painting. They won't flake, rot, blister, peel, pit or corrode.** Plus they're warranted against corrosion for the life of the products† with no washing or waxing required.**



QUALITY SO SOLID, THE WARRANTY IS TRANSFERABLE**†

Our renowned Owner-2-Owner® limited warranty is fully transferable and not prorated, making it one of the best coverage plans available — which means it can add resale value for your customers. It's also supported by the industry's largest service network.

OWNER2OWNER®
LIMITED WARRANTY

ARCHITECTURAL AUTHENTICITY

A-Series products and their detailed design options make architectural authenticity not only possible but also easy to achieve. To find A-Series windows, doors, hardware, exterior trim and color palettes that are authentic to a particular home's architectural style, see our style library at andersenwindows.com/stylelibrary.

ENERGY-SAVING GLASS AND DESIGN

Andersen makes windows and doors with options that make them ENERGY STAR® v. 6.0 certified throughout the United States.

Visit andersenwindows.com/energystar for more information and contact your dealer to verify that the product with your glass option is ENERGY STAR certified in your area.



PHIUS CERTIFICATION **NEW!**

A-Series casement, awning and fixed transom windows are Phius (Passive House Institute US) certified, helping you work your designs toward a zero-carbon footprint.



*Available on select A-Series products.

**Visit andersenwindows.com/warranty for details.

†Hardware excluded.

All logos and marks are trademarks of their respective owners.

RIGOROUSLY TESTED

A-Series products have withstood testing that has taken them from temperatures as cold as Alaskan winters to the heat of Death Valley summers. They've stood up to hurricane-force winds and prolonged exposure to sea air.* A-Series standard products feature the following ratings:†

Windows	PG50 (DP50)
Gliding Patio Doors	PG50 (DP50)**
Hinged Patio Doors	PG45 (DP45)

PG50†

ADH4080 +50/-50
(AAMA/WDMA/CSA 101/1.5.2/A440-11)

Ratings vary by product performance and unit size. See the performance section in this guide for specific unit performance. Visit andersenwindows.com for up-to-date performance values.

SEALS OUT THE WEATHER

Weather-resistant seals stand up to eight inches of rain per hour and hurricane-force winds.† Double-hung windows feature a dual-bulb seal, and casement windows use refrigerator-type gaskets to help keep air and water out.

PERFORMANCE GRADE **NEW!** (PG) UPGRADES

PG upgrades are now available for A-Series windows, in addition to A-Series patio doors. Products with PG upgrades achieve higher air, water and structural ratings as opposed to standard performance products. Availability is based on product type and size.

PG70††

ADH4080 PGUP +70/-70
(AAMA/WDMA/CSA 101/1.5.2/A440-11)

OPTIONS FOR THE HARSHTEST WEATHER

A-Series products are available with Stormwatch® Protection to achieve higher air, water and structural ratings. They also include impact-resistant glass for wind-borne debris protection to maintain the structural integrity of the unit after impact. Visit andersenwindows.com/coastal or refer to the Andersen® A-Series Coastal Product Guide for more information. See your local building code official for specific requirements.

PG70†+

ADH4080 SW Impact +70/-70
(AAMA/WDMA/CSA 101/1.5.2/A440-11)

StormWATCH
PROTECTION

*Tested to AAMA/WDMA/CSA 101/1.5.2/A440-08 & -11 PG50.

**Rating applies to all gliding patio doors except two-panel 10' tall doors (PG45) and three- and four-panel 8' and 10' tall doors (PG40).

†ADH4080 +50/-50 (AAMA/WDMA/CSA 101/1.5.2/A440-11). For more information, visit andersenwindows.com/a-series.

††ADH4080 PGUP +70/-70 (AAMA/WDMA/CSA 101/1.5.2/A440-11). For more information, visit andersenwindows.com/a-series.

‡ADH4080 SW Impact +70/-70 (AAMA/WDMA/CSA 101/1.5.2/A440-11). For more information, visit andersenwindows.com/coastal.





ARCHITECTURALLY DETAILED DESIGN

COMMON SIZE GRID

Common sizes in 4" (102) increments are based on the rough opening to simplify framing and specifying. Even-inch sizes eliminate fractions and reduce job site errors. A 3/4" (19) gap horizontally and vertically leaves room for shims, insulation and sill flashing.

CUSTOM SIZING

All A-Series windows and patio doors can be ordered in 1/8" (3) increments, providing flexibility for replacement, remodeling, new construction and light commercial projects.

COMMON GLASS SETBACK

A common glass setback on A-Series windows and patio doors delivers noticeably clean shadow lines both inside and out.

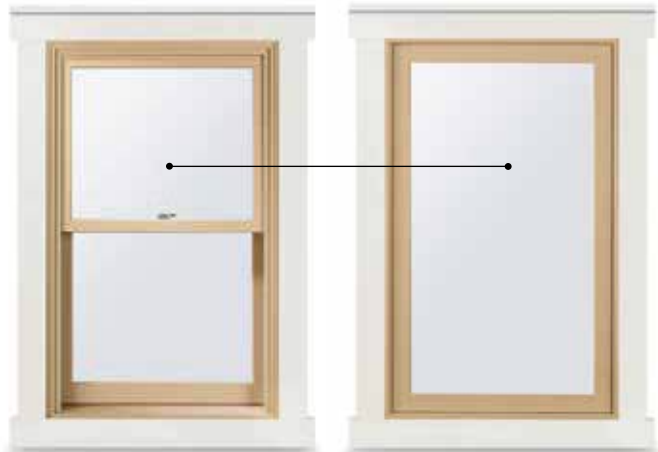

The upper sash of double-hung windows aligns perfectly with casement windows, awning windows, picture windows, patio doors and transoms.

Dimensions in parentheses are in millimeters.

COMPLETE ALIGNMENT

Common sight lines allow you to specify any combination of window styles and still have them match and align perfectly.



Windows share the same sash design, grille profiles and frame depth for consistent beauty with classic appeal.



EASY MATH

The A-Series window system simplifies selection and installation of multiple windows within a single rough opening. 3/4" (19) horizontal and vertical joints keep sizing consistent no matter how many or what size windows you combine.

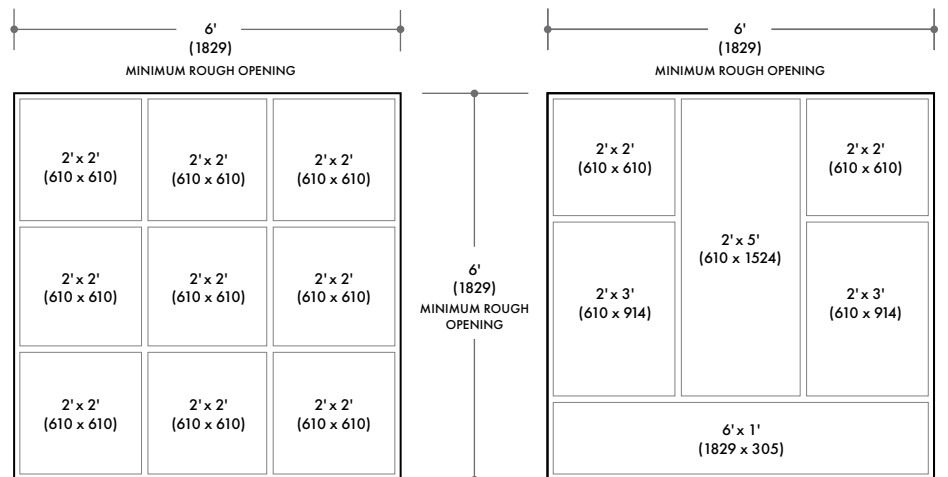

The spacing in these illustrations is exaggerated for demonstration purposes.



ANDERSEN® PRODUCTS
**RATE #1 IN
QUALITY AND
PERFORMANCE.***

*2022 Andersen brand surveys of U.S. contractors, builders and architects.

WINDOW & DOOR TYPES

A-SERIES WINDOWS

The A-Series window lineup consists of casement, awning, double-hung, picture, transom (fixed or venting) and specialty shape windows. Every type is meticulously designed to fit a variety of different architectural styles. And with common sight lines they're designed to align perfectly no matter how you combine them.

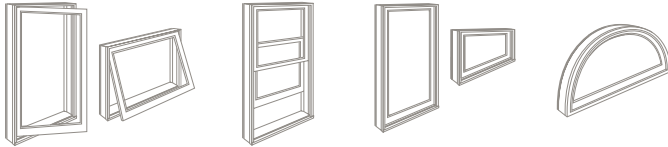

Casement/Awning Double-Hung Picture & Transom Specialty



A-SERIES PATIO DOORS

The A-Series door lineup consists of gliding and hinged patio doors (inswing and outswing) with options to add sidelights and transoms for an even stronger connection to the outdoors.

Contemporary Panels **NEW!**

The new A-Series contemporary panels have a 6 1/4" (159) bottom rail as opposed to traditional panels with a 10 1/2" (267) bottom rail. Matching patio door sidelights and transoms are available.

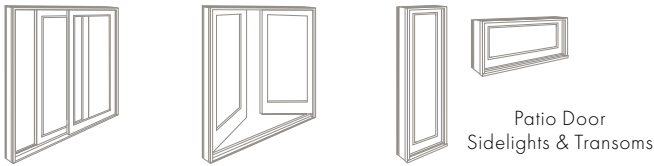

Gliding Hinged Patio Door Sidelights & Transoms



COMPLEMENTARY CASEMENT WINDOWS

Our complementary casement windows offer easy operation along with old-world style. They include French casements — twin sash inside one frame with no mullion post between them like ordinary casements — that give you a totally unobstructed view. Complementary casement windows are available in rectangles, trapezoids and a variety of arched shapes.



COMPLEMENTARY CURVED TOP PATIO DOORS

With features like Romanesque arches and sweeping curves, nothing else quite matches the grandeur our complementary curved top inswing and outswing patio doors can bring to a home.



Dimensions in parentheses are in millimeters.

EXTERIORS

A-Series products are available in a wide range of exterior colors and exterior trim choices. Even in harsh conditions they're virtually maintenance free, hold their original vibrant colors, never need painting and won't flake, rot, blister, peel, pit or corrode.* Select any combination of colors shown here for your exterior frame, sash and trim.

EXTERIOR COLORS

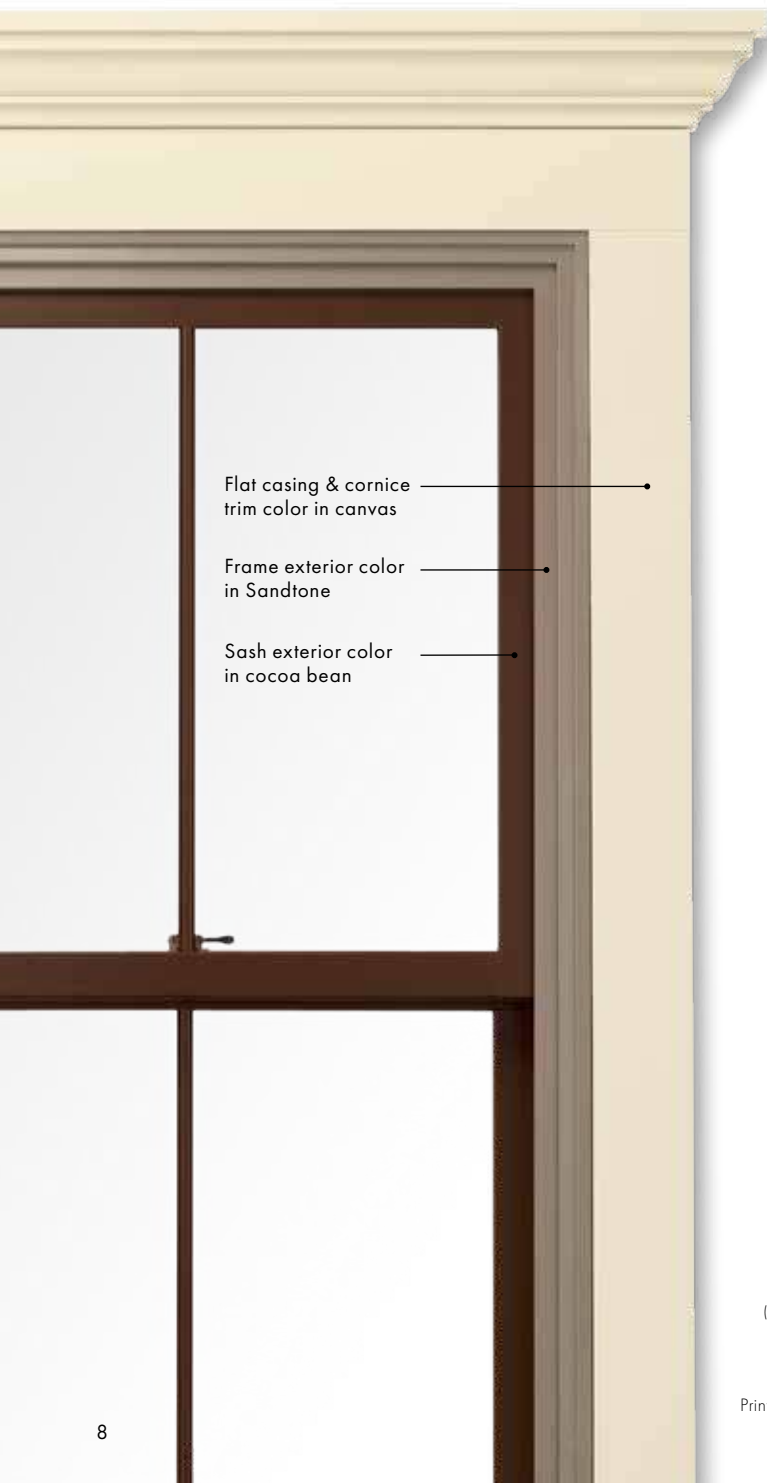

EXTERIOR TRIM SYSTEM

- Complements a wide range of architectural styles
- Low maintenance and never needs painting
- Order as pre-assembled surrounds, in precut kits or as individual components
- Innovative trim attachment flange on A-Series windows allows pre-assembled exterior trim surrounds to be installed in seconds
- Installed independent of the window's or door's water management system
- For more information, see the exterior trim section starting on page 191.

EXTERIOR TRIM STYLE OPTIONS



*Visit andersenwindows.com/warranty for details. Printing limitations prevent exact duplication of colors. See your Andersen supplier for actual color samples.

INTERIORS

With six natural wood species, six rich factory-finished stain options and a variety of painted interiors, A-Series products provide the flexibility to create interiors that please both you and your customers.

INTERIOR WOOD SPECIES



FACTORY-FINISHED INTERIORS

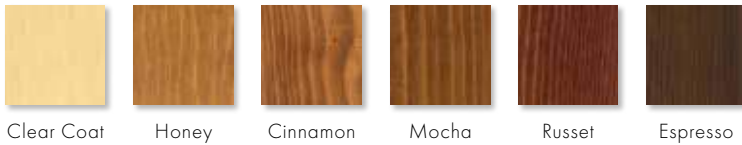

All wood interiors are unfinished unless a finish is specified. For windows, clear coat is now available on all wood species; all other factory finishes are available on pine, maple and oak. For doors, factory finishes are available on pine, maple and oak. Finishes shown above on pine. **NEW!**

INTERIOR PAINT COLORS

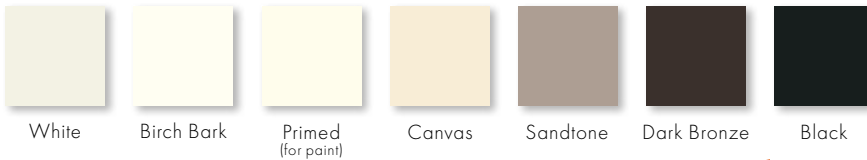

For windows, painted interiors are now available on maple in addition to pine. For doors, painted interiors are available on pine. Additional colors to match all 11 exterior colors are also available; see your Andersen supplier for details. **NEW!**

4-TONE INTERIORS **NEW!**

Mix and match up to four interior wood species, stains and/or colors for your window's frame, sash, grilles and extension jambs to achieve a look unique to your project.

*Actual wood species is either Sapele or Sipo, both non-endangered species grown in Africa, with color and characteristics similar to Central American mahoganies. Naturally occurring variations in grain, color and texture of wood make each window one of a kind. We cannot guarantee consistency in wood grain and/or color within a particular species, product or project. Printing limitations prevent exact duplication of colors. See your Andersen supplier for actual color samples.





ANDERSEN® IS THE
WINDOW & DOOR BRAND
HOMEOWNERS
RECOGNIZE
THE MOST.*

*2022 Andersen brand survey of U.S. homeowners.

WINDOW HARDWARE

The hardware* for our A-Series windows is created exclusively for Andersen and is made of forged metal for added strength. A range of available finishes makes it easy for customers to coordinate their window hardware with their cabinet hardware, faucets and other room décor.

Casement, Awning & Venting Transom



CONTEMPORARY FOLDING

Black | Bright Brass | Oil Rubbed Bronze
Satin Nickel | Stone | White



TRADITIONAL FOLDING

Antique Brass | Black | Bright Brass | Distressed Bronze
Distressed Nickel | Oil Rubbed Bronze | Satin Nickel
Stone | White

Folding handles avoid interference with window treatments.
Bold name denotes finish shown.

Double-Hung



Lock & Keeper

Antique Brass | Black | Bright Brass | Distressed Bronze | Distressed Nickel
Oil Rubbed Bronze | **Satin Nickel** | Stone | White



Optional Bar Lift



Optional Hand Lift



Optional Finger Lift

Antique Brass | Black | Bright Brass | Distressed Bronze | Distressed Nickel
Oil Rubbed Bronze | **Satin Nickel** | Stone | White

Bold name denotes finish shown.

HARDWARE FINISHES



Antique Brass | Black | Bright Brass | Distressed Bronze | Distressed Nickel | Oil Rubbed Bronze | Satin Nickel | Stone | White



EASY TILT-TO-CLEAN

A-Series double-hung windows include a tilt-to-clean feature, with one hand operation, for easy exterior glass cleaning of both sash.

*Hardware sold separately except double-hung lock and keeper. Distressed bronze and oil rubbed bronze are "living" finishes that will change with time and use. Printing limitations prevent exact replication of finishes. See your Andersen supplier for actual finish samples.

PATIO DOOR HARDWARE

Patio door hardware* is available in a variety of designs to match virtually any style. Yuma®, Encino®, Newbury® and Anvers® hardware options each feature solid drop-forged brass for added strength, while Albany and Tribeca® hardware options are made of zinc die-cast with durable powder-coated finishes. Additional hardware options such as exterior keyed locks, matching hinge finishes and more are also available.



Bold name denotes finish shown.

HARDWARE FINISHES

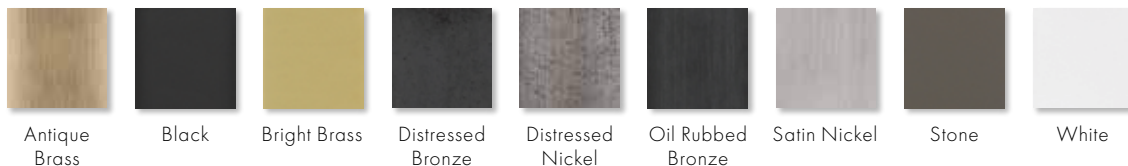

*Hardware sold separately.

Bright brass and satin nickel finishes on patio door hardware feature a 10-year limited warranty.

Matching hinges available in most finishes for inswing patio doors. Distressed bronze and oil rubbed bronze are "living" finishes that will change with time and use. Printing limitations prevent exact replication of finishes. See your Andersen supplier for actual finish samples.

FSB® HARDWARE FOR HINGED PATIO DOORS

Durable FSB hinged door hardware* features clean lines and a sleek satin finish for a thoroughly modern look.

Choose from four styles.

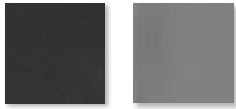

Black
Anodized
Aluminum

Satin
Stainless
Steel

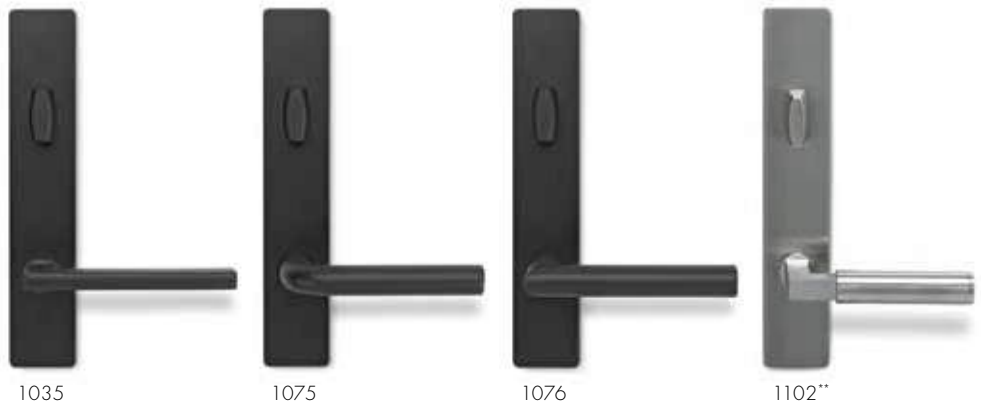

1035

1075

1076

1102**

YALE® ASSURE LOCK® FOR HINGED PATIO DOORS†

The sleek key-free lock* includes Bluetooth® technology for keyless unlocking. Available with Anvers® hardware* in black, satin nickel and white. Compatible with touchscreen, touchscreen + Z-Wave® and touchscreen + Bluetooth + WiFi® kit.

One-Touch Locking – Lock up without the hassle of keys by simply tapping the keypad.

Key Free – No cylinder means no lost keys, and no pick and bump break-ins.

Battery Backup – Never lose power; the lock can be energized with a 9V battery.

Remote Access – Monitor, lock and unlock from anywhere.††



Black

Satin Nickel

White



FLUSH HARDWARE FOR GLIDING PATIO DOORS **NEW!**



Sleek, low profile hardware* for gliding patio doors is available in keyed and non-keyed options for both traditional and contemporary door panels. Shown in satin nickel.

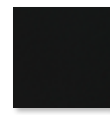

Black



Oil Rubbed
Bronze



Satin Nickel



White



*Hardware sold separately.

**FSB style 1102 is not available in black anodized aluminum.

†Available on select Andersen® hinged patio doors; see your Andersen supplier for details.

††When properly configured and maintained with a professionally installed security system and/or self-monitoring system compatible with Honeywell® 5800 controls. See your Andersen supplier for more information.

Distressed bronze and oil rubbed bronze are "living" finishes that will change with time and use. Printing limitations prevent exact replication of finishes. See your Andersen supplier for actual finish samples.

All marks are trademarks of their respective owners.

GLASS

Choose from a variety of high-performance glass options, including triple-pane glass and HeatLock® technology for even greater energy efficiency.



Low-E4® SmartSun™ Glass

Helps shield your home from the sun's heat, filtering out 95% of harmful UV rays while letting sunlight shine through, plus it provides all the benefits of Low-E4 glass.



Low-E4 Glass

Outstanding thermal performance for climates where both heating and cooling costs are a concern. It comes standard on all A-Series products and is up to 57% more energy efficient than ordinary dual-pane glass.*



Low-E4 Sun Glass

Outstanding thermal performance in southern climates where less solar heat gain is desired. It's tinted for maximum protection from the effects of intense sunlight while providing all the benefits of Low-E4 glass.

Triple-Pane Glass

Three panes of glass are combined with either argon gas blend or air and Low-E coatings to provide enhanced energy performance. Adding triple-pane glass to one of our windows or doors results in a lower U-Factor value than using regular dual-pane glass.

HeatLock Technology

Our HeatLock coating can increase the energy efficiency of any A-Series window or door with Low-E4 or SmartSun glass. Applied to the room-side glass surface, it reflects heat back into the home for improved performance.

GLASS	ENERGY		LIGHT	
	U-Factor <small>How well a product prevents heat from escaping.</small>	Solar Heat Gain Coefficient <small>How well a product blocks heat caused by sunlight.</small>	Visible Light Transmittance <small>How much visible light comes through a product.</small>	UV Protection <small>How well a product blocks ultraviolet rays.</small>
SmartSun	● ● ● ○	● ● ● ●	● ● ● ○	● ● ● ●
SmartSun with HeatLock Coating	● ● ● ●	● ● ● ●	● ● ○ ○	● ● ● ●
Low-E4	● ● ● ○	● ● ● ○	● ● ● ○	● ● ● ○
Low-E4 with HeatLock Coating	● ● ● ●	● ● ● ○	● ● ● ○	● ● ● ○
Sun	● ● ● ○	● ● ● ●	● ○ ○ ○	● ● ● ○
PassiveSun®	● ● ● ○	● ○ ○ ○	● ● ● ○	● ● ● ○
PassiveSun with HeatLock Coating	● ● ● ○	● ○ ○ ○	● ● ● ○	● ● ● ○
Triple-Pane with Low-E Coating on two surfaces	● ● ● ●	● ● ● ○	● ● ○ ○	● ● ● ●
Clear Dual-Pane	● ○ ○ ○	○ ○ ○ ○	● ● ● ●	○ ○ ○ ○

Center of glass performance only. Ratings based on glass options as of August 2022. Visit andersenwindows.com/energystar for ENERGY STAR® map and NFRC total unit performance data or contact your Andersen supplier for product specific performance data.

*Summer values are based on comparison of Andersen® A-Series double-hung window SHGC to the SHGC for clear dual-pane glass non-metal frame default values from the 2006, 2009, 2012, 2015 and 2018 International Energy Conservation Code "Glazed Fenestration" Default Tables.

See your Andersen supplier for actual glass samples.

"ENERGY STAR" is a registered trademark of the U.S. Environmental Protection Agency.

STORMWATCH® PROTECTION

A-Series products are available with impact-resistant glass in addition to structural upgrades to meet the tough building codes of hurricane-prone coastal areas. See your local code official for specific requirements.



ADDITIONAL GLASS OPTIONS

Tempered safety glass is standard on patio doors and required by code for larger window sizes.*

Laminated glass is available for added strength, enhanced security and sound control.

Patterned glass lets in light while obscuring vision and adds a unique, decorative touch.

Cascade and Reed patterns can be ordered with either a vertical or horizontal orientation.



TIME-SAVING FILM

We protect our products during delivery and construction with translucent film on the glass that peels away for a virtually spotless window.

Visit andersenwindows.com/glass for more details on our glass options.



*See your local code official for code requirements in your area.

**Visit andersenwindows.com for warranty details.

Printing limitations prevent exact color duplication. See your Andersen supplier for details. "ENERGY STAR" is a registered trademark of the U.S. Environmental Protection Agency.

GLASS SPACER OPTIONS



Black or white glass spacers are available as a standard offering on A-Series products, in addition to stainless steel glass spacers, to provide more ways to customize project designs and achieve a contemporary style. Colored glass spacers blend in with the color of the window or door for a sleek design, or serve as a shadow line.

Add full divided light grilles, and the grille spacer bar between the glass will match the selected glass spacer color.

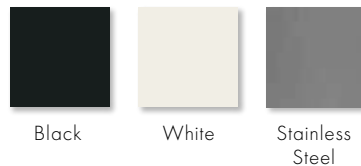

BETWEEN-THE-GLASS ART GLASS

With our between-the-glass art glass you can add interest, create focal points and make your work stand out. See page 16 or visit andersenwindows.com/artglass for more information.

BLINDS-BETWEEN-THE-GLASS FOR PATIO DOORS



Conveniently located between the panes of insulated glass, and protected from dust and damage for long-lasting protection, blinds-between-the-glass are available on select sizes of A-Series patio doors. The cordless design easily raises, lowers or tilts the blinds for control of light and privacy. Available in slate gray or white, and can be ordered with any interior or exterior door finish. Blinds are covered by a 10-year limited warranty.**

BETWEEN-THE-GLASS ART GLASS

A-Series between-the-glass art glass places the decorative panel between the glass panes, providing superior protection for the art glass and making it easy to keep clean. Historic patterns and Classic Series designs, representing major architectural themes from the late 1800s through the 1930s, are available in standard color palettes or custom color combinations.*

HISTORIC

Diamond Grid

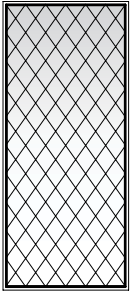

Queen Anne

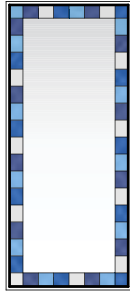
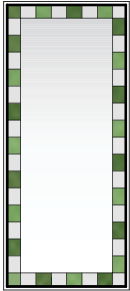

Olive green, clear waterglass, moss green and clear
Pale blue, navy blue, clear waterglass, dark blue and clear

Arts & Crafts

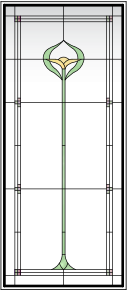

Olive green, pale amber, clear waterglass, avocado glimmer and tangerine glimmer

Rectangular Grid

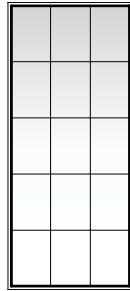

Amber

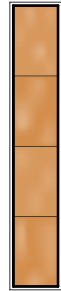

CLASSIC SERIES**

Lotus

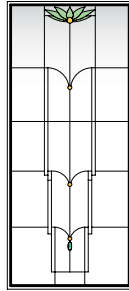

Light green with amber and green jewels
Sand with pink jewels

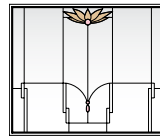

Regency

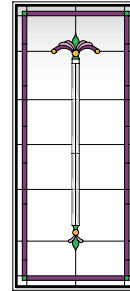

Deep rose, deep green and rose with opal amber jewels
Sand, deep teal, topaz and copper with smoke jewels

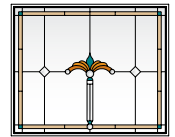

Victoria

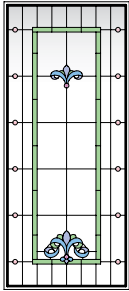

Light green, lilac and light blue with pink and lilac jewels
Violet, deep rose and deep green with amber jewels

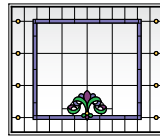

Diamond Lights



Clear fan-shaped bevels

ART GLASS COLORS

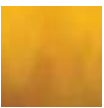

Amber

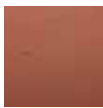

Copper



Dark Blue



Deep Green



Deep Rose



Deep Teal



Golden Green



Kelly Green



Light Blue



Light Green

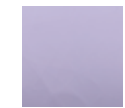

Lilac



Moss Green

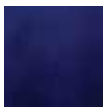

Navy Blue



Olive Green



Pale Amber

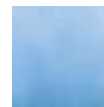

Pale Blue

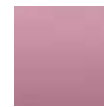

Rose



Sand



Topaz



Umber



Violet

Iridescent Accents



Avocado Glimmer



Kiwi Glimmer



Tamarind Glimmer



Tangerine Glimmer

Jewel Accents



Amber



Clear



Green



Lilac



Opal Amber



Pink



Smoke

Clear, clear antique, clear waterglass, along with textured semi-privacy (double glue chip) and light restoration glass are also available. For custom capabilities, contact your Andersen supplier.

*Color palettes and jewel accents for custom combinations are predetermined by style of art glass. For custom capabilities, see your Andersen supplier.

**Classic Series patterns are also available with semi-privacy glass or clear antique glass in place of colored glass. Additional color palettes are available. Patterns vary based on window or panel size and shape. Illustrations (except Amber) depict patterns for 6068 patio door panel. See your Andersen supplier for pattern availability.

Art glass changes appearance greatly based on lighting in its environment, making it beautiful to look at yet difficult to represent accurately in print. Printing limitations prevent exact color duplication. Colors in the Historic patterns and Classic Series designs may also vary. See your Andersen supplier for actual color samples.

INSECT SCREENS

Our TruScene® insect screens provide more than 50% greater clarity than our conventional insect screens for a beautifully unobstructed view. They let in 25% more fresh air* all while keeping out unwanted small insects.

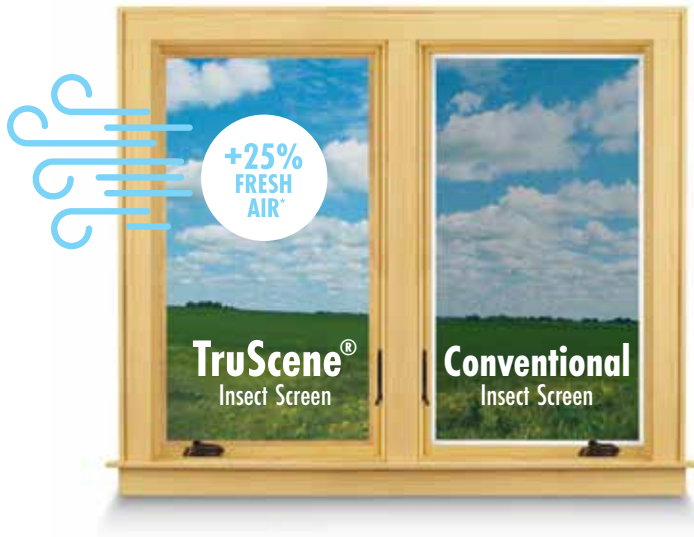

TRUSCENE INSECT SCREENS

TruScene insect screens are available for all venting windows. Insect screen frames for casement, awning and venting transom windows are available in white, gold dust and stone as well as prefinished in six wood veneers, six stains and all interior paint colors. Frames for double-hung windows match the product's exterior color.



Interior TruScene insect screen with a pine frame and clear coat finish.

CONVENTIONAL INSECT SCREENS

Conventional insect screens are available for venting windows and doors. Insect screen frames for casement, awning and venting transom window are available in interior paint options, as well as gold dust and stone. Frames for outswing patio doors are available in white, gold dust, pine, maple and oak finishes and in six stain options to match the door's interior. Frames for gliding and inswing patio doors and double-hung windows match the product's exterior color.



White



Gold Dust



Stone

Interior conventional insect screen frames for casement, awning and venting transom windows shown in three of the color options.

INSECT SCREEN CONFIGURATIONS

Windows

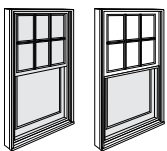

Full insect screen for venting windows.
Half insect screen for the lower sash of double-hung windows.

Gliding Patio Doors

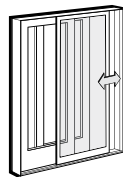

Premium top-hung or conventional gliding insect screen for two- and four-panel gliding doors.



Retractable insect screen for two-panel gliding doors. Installed on the exterior, it neatly retracts into a small canister.

Hinged Patio Doors



Single- or double-hinged insect screen for inswing single- and two-panel doors.

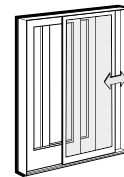

Premium top-hung or conventional gliding insect screen for two- and three-panel inswing doors.

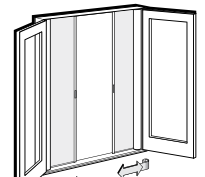

Retractable insect screen for two-panel outswing doors. Installed on the interior, it neatly retracts into a small canister.

*TruScene insect screens let in over 25% more fresh air than standard Andersen fiberglass insect screens.

REALTORS AGREE THAT
ANDERSEN® PRODUCTS
**INCREASE THE
VALUE OF A
HOME BY AT
LEAST 15%.***



*2022 Andersen brand survey of U.S. realtors and their experience for the homes they sell.

GRILLES

A-Series windows and patio doors offer a variety of architecturally authentic grille types and standard patterns. We'll also work with you to provide your customers with custom grille designs for a signature look.

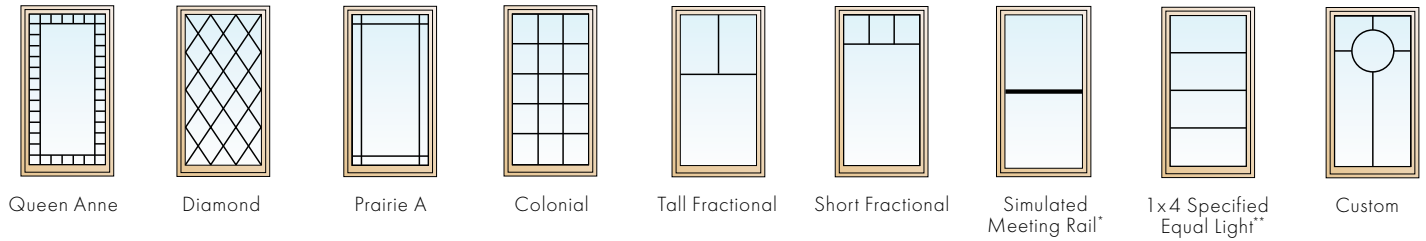

FULL DIVIDED LIGHT

Permanently applied to the interior and exterior of the window, with a spacer between the glass.

Full Divided Light with Energy Spacer

Full divided light with a narrow spacer bar that provides a 3 mm gap around the spacer to minimize transfer of heat and cold to the interior glass surface, improving overall thermal performance.

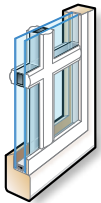

Permanent exterior and permanent interior with spacer



Permanent exterior and permanent interior with energy spacer

SIMULATED DIVIDED LIGHT

Permanent grilles on the exterior and interior, with no spacer between the glass. We also offer permanent exterior grilles with removable interior grilles available in natural wood or prefinished white.



Permanent exterior and permanent interior

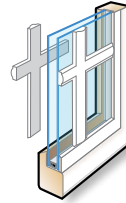

Permanent exterior and removable interior

CONVENIENT CLEANING

Removable interior grilles come off for easy cleaning. Finelight™ grilles-between-the-glass are installed between the glass panes, and feature a contoured 1" (25) or 3/4" (19) profile.

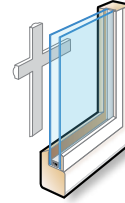

Removable interior

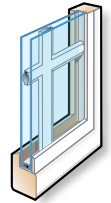

Finelight grilles-between-the-glass†

GRILLE BAR WIDTHS

Traditional



3/4" (19)

7/8" (22)

1 1/8" (29)

2 1/4" (57)

Contemporary for Patio Doors **NEW!**



5/8" (16)

3/4" (19)

2 1/4" (57)

3 1/2" (89)

Wide traditional grilles can be positioned horizontally across the center of a casement window to simulate the look of a double-hung window.* New contemporary grilles can be used for door products with contemporary options. Actual size shown.

* Simulated meeting rails are available in 7/8" (22), 1 1/8" (29) and 2 1/4" (57) widths.

** Specify number of same-size rectangles wide or high. Some restrictions may apply.

† 7/8" (22), 1 1/8" (29), 2 1/4" (57) and 3 1/2" (89) widths are not available in Finelight grilles-between-the-glass.

For standard grille patterns, refer to the detailed product sections in this guide or contact your Andersen supplier. Some grille patterns are not available in all configurations or products. Dimensions in parentheses are in millimeters.

EASY CONNECT JOINING SYSTEM

Our Easy Connect Joining System* provides enhanced performance, design flexibility, and job site conveniences. Choose from three options — partially assembled factory-prepped combinations, fully assembled factory-joined combinations or on-site joining kits — to achieve monumental window combinations. These joining options utilize the strength and durability of fiberglass construction, and offer the design flexibility of achieving both one-way and two-way combinations.

Visit andersenwindows.com/joining for more information.

Innovative patented joining system utilizes 5 3/4" (146) interlocking fiberglass joining plates for 4 9/16" (116) base jamb depths. 7 3/4" (197) interlocking fiberglass joining plates are available for higher performance and are required for hinged inswing patio doors with 6 9/16" (167) base jamb depths. They are available in 14' (4267) lengths, and are field cut and applied.



Factory-Prepped Combinations

Receive lighter, easier-to-handle, pre-assembled smaller combinations that join as you install them into the rough opening, making it easier to install large combinations. In fact, most contractors surveyed said they could reduce the number of installers by 50% using the Andersen® Easy Connect Joining System.**

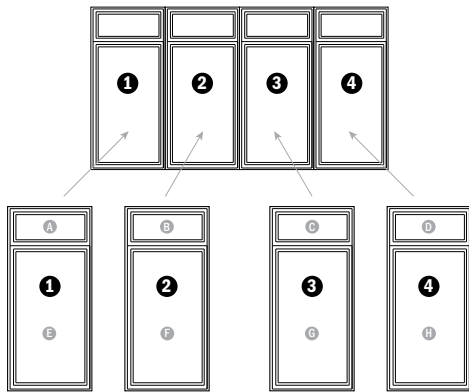

Factory-Joined Combinations

Eliminate the need for job site assembly and receive fully joined, factory-assembled window combinations to fit rough openings up to 12' (3658) x 8' (2438) or 8' (2438) x 12' (3658).

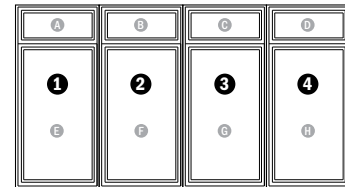

	ASSEMBLY	READY TO INSTALL	NUMBER OF INSTALLERS**	HALLMARK CERTIFIED†	TESTED TO AAMA 450	PERFORMANCE	COMBINATION SIZE LIMITATIONS
FACTORY-PREPARED COMBINATIONS	IN THE OPENING	●	FEWER	●	●	Extensive unit combination size options available certified to PG70† High Velocity Hurricane Zone (HVHZ) approved	ROUGH OPENING MAX: 12' (3658) in one direction with no maximum in the other direction
FACTORY-JOINED COMBINATIONS	FACTORY	●	MORE	●	●	Extensive unit combination size options available certified to PG70† High Velocity Hurricane Zone (HVHZ) approved	ROUGH OPENING MAX: 12' x 8' or 8' x 12' (3658 x 2438 or 2438 x 3658)
JOINING KITS	JOB SITE		MORE	●	●	Extensive unit combination size options available certified to PG70† High Velocity Hurricane Zone (HVHZ) approved	ROUGH OPENING MAX: 12' (3658) in one direction with no maximum in the other direction

*Available on select windows, see your Andersen supplier for details.

**69% of 156 builders/general contractors in a 2018 survey said they could reduce the number of installers by half using the Easy Connect Joining System when comparing the installation of a 12' (3658) wide x 8' (2438) high pre-assembled window combination unit with four 3' (914) wide x 8' (2438) high window combination units.

†Easy Connect and other fiberglass joins are certified up to PG70 when installed according to Andersen installation instructions.

Structural performance of any combination is only as high as the lowest structural performance of any individual unit or joining material in the combination.

Dimensions in parentheses are in millimeters.

WINDOWS

Casement

Table of Sizes 26-27
 Specifications 28-31
 Grille Patterns 37
 Window Details 31

Awning

Table of Sizes 32-33
 Specifications 34-36
 Grille Patterns 37
 Window Details 37

Double-Hung

Table of Sizes 38-39
 Specifications 40-42
 Grille Patterns 43
 Window Details 43

Picture

Table of Sizes 44-48
 Specifications 49-51
 Grille Patterns 46
 Window Details 51

Fixed & Venting Transom

Table of Sizes 52-56
 Specifications 54-58
 Grille Patterns 58
 Window Details 59

Joining Details 60-62
 Custom Sizes 63-65
 Combination Designs 196
 Product Performance 206

CUSTOM SIZING
 in 1/8" (3) increments 
CUSTOM SIZES

Dimensions in parentheses are in millimeters.



FEATURES

CASEMENT & AWNING

FRAME

A The frame is constructed with wood and Fibrex® composite material exterior. This construction produces a rigid frame and a low-maintenance, durable exterior.

B Wood members are treated with a water-repellent preservative for long-lasting* protection and performance.

C The weatherstrip system combines an exterior watershed design and a foam weatherstrip seal between the sash and frame, providing a long-lasting, energy-efficient barrier against wind, water and dust.

D A factory-applied rigid vinyl installation flange helps seal the unit to the structure. Available in a standard design or with an exterior trim installation flange (shown). The exterior trim installation flange allows for Andersen® exterior trim surrounds to be applied in seconds after window installation.

SASH

E Fiberglass construction provides durable, strong and long-lasting** performance. The Fiberglass is finished with a Flexacron® paint system. This stabilized polyester paint is electrostatically applied for maximum protection and a lustrous, low-maintenance finish.

Traditional architectural style:

- Classic chamfer detailing
- The look of mortise-and-tenon joinery
- A tall bottom rail on casement and awning windows aligns with double-hung and picture windows for common sight lines

F Natural wood interiors are treated with a water-repellent preservative for long-lasting* protection and performance. Interior stops are fastened using a compression fit system so there are no nail holes to fill.



G GLASS

See Common Features on page 23 for details.

HARDWARE

Smooth Control Hardware System

Smooth operation is provided by a worm gear drive design that makes opening and closing almost effortless, regardless of the unit size. Hinges allow for a wash mode or widest clear opening depending on the window size. Hardware is sold separately. Hardware option and finish must be specified.

Single-Action Casement Lock



A single-action lock easily releases all locking points on the casement sash, while the reach-out action eliminates binding when closing. The lock is offered in finishes that coordinate with your specified hardware option.

Awning Sash Locks

Awning windows feature dual sash locks. Hardware style and finish options are compatible with casement windows to ensure consistency in appearance when used in combination designs.

PERFORMANCE OPTIONS

See Common Features on page 23 for details.

DOUBLE-HUNG

FRAME

A The frame is constructed with wood and Fibrex composite material exterior. This construction produces a rigid frame and a low-maintenance, durable exterior.

B Wood members are treated with a water-repellent preservative for long-lasting* protection and performance.

C The dual weatherstrip system utilizes a double foam-filled design that creates a pressure equalization chamber, knocking down driving rain and delivering a long-lasting, energy-efficient barrier against wind, water and dust.

D Traditional sloped sill design.

E For units with a white exterior, the exterior jamb liner is white. For all other exterior colors, the exterior jamb liner is Sandtone. All double-hung windows include lower jamb liner cover/inserts that match the product's exterior color.

F A factory-applied rigid vinyl installation flange helps seal the unit to the structure. Available in a standard design or with an exterior trim installation flange (shown). The exterior trim installation flange allows for Andersen exterior trim surrounds to be applied in seconds after window installation.

SASH

G Fiberglass construction provides durable, strong and long-lasting** performance. The Fiberglass is finished with a Flexacron paint system. This stabilized polyester paint is electrostatically applied for maximum protection and a lustrous, low-maintenance finish.

Traditional architectural style:

- Classic chamfer detailing
- The look of mortise-and-tenon joinery
- A tall bottom rail on double-hung windows aligns with casement, awning and picture windows for common sight lines

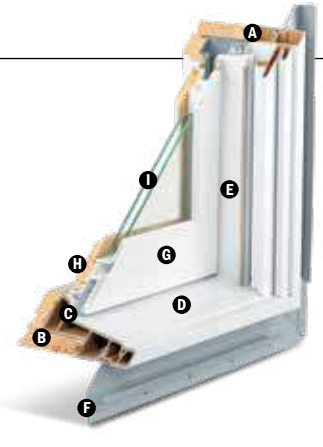

H Natural wood interiors are treated with a water-repellent preservative for long-lasting* protection and performance. Interior stops are fastened from behind so there are no nail holes to fill.

I GLASS

See Common Features on page 23 for details.

HARDWARE

Sash Lock



Traditional spoon lock design has an integrated tilt-to-clean feature, so both sash can be cleaned from the inside.

PERFORMANCE OPTIONS

See Common Features on page 23 for details.

SASH OPTIONS**



Cottage Style

Reverse Cottage Style

*Visit andersenwindows.com/warranty for details.

**Shown on 400 Series tilt-wash double-hung full-frame windows.

*Flexacron® is a registered trademark of PPG Industries, Inc.

PICTURE WINDOW & FIXED TRANSOM

FRAME

The frame is constructed with wood and fiberglass exterior. This construction produces a rigid frame and a low-maintenance, durable exterior.

Wood members are treated with a water-repellent preservative for long-lasting* protection and performance.

A factory-applied rigid vinyl installation flange helps seal the unit to the structure. Available in a standard design or with an exterior trim installation flange. The exterior trim installation flange allows for Andersen® exterior trim surrounds to be applied in seconds after window installation.

Fiberglass construction provides durable, strong and long-lasting* performance. The fiberglass is finished with a Flexacron® paint system. This stabilized polyester paint is electrostatically applied for maximum protection and a lustrous, low-maintenance finish.

Traditional architectural style:

- Classic chamfer detailing
- The look of mortise-and-tenon joinery
- A tall bottom rail on picture windows aligns with casement, awning and double-hung windows for common sight lines
- A shorter bottom rail on fixed transom windows provides an attractive sight line when joined above other A-Series windows or patio doors

Natural wood interiors are treated with a water-repellent preservative for long-lasting* protection and performance. Interior stops are fastened using a compression fit system so there are no nail holes to fill.

GLASS

See Common Features below.

PERFORMANCE OPTIONS

See Common Features below.

VENTING TRANSOM

FRAME

The frame is constructed with wood and Fibrex® composite material exterior. This construction produces a rigid frame and a low-maintenance, durable exterior.

Wood members are treated with a water-repellent preservative for long-lasting* protection and performance.

The weatherstrip system combines an exterior watershed design and a foam weatherstrip seal between the sash and frame, providing a long-lasting,* energy-efficient barrier against wind, water and dust.

A factory-applied rigid vinyl installation flange helps seal the unit to the structure. Available in a standard design or with an exterior trim installation flange. The exterior trim installation flange allows for Andersen exterior trim surrounds to be applied in seconds after window installation.

SASH

Fiberglass construction provides durable, strong and long-lasting* performance. The fiberglass is finished with a Flexacron paint system. This stabilized polyester paint is electrostatically applied for maximum protection and a lustrous, low-maintenance finish.

Traditional architectural style:

- Classic chamfer detailing
- The look of mortise-and-tenon joinery
- A shorter bottom rail provides an attractive sight line when joined above other A-Series windows or patio doors

Natural wood interiors are treated with a water-repellent preservative for long-lasting* protection and performance. Interior stops are fastened using a compression fit system so there are no nail holes to fill.

GLASS

See Common Features below.

HARDWARE

Smooth operation is provided by a worm gear drive design that makes opening and closing almost effortless, regardless of the unit size.

Sash Locks

Venting transoms feature dual sash locks. Hardware style and finish options are compatible with casement windows to ensure consistency in appearance when used in combination designs.

PERFORMANCE OPTIONS

See Common Features below.

COMMON FEATURES

GLASS

In addition to stainless steel glass spacers, black or white glass spacers are available to allow the spacer to blend in with the unit color.

¾" (19) dual-pane glass construction provides exceptional energy performance. High-Performance dual-pane glass options include:

- Low-E4® glass
- Low-E4 HeatLock® glass
- Low-E4 SmartSun™ glass
- Low-E4 SmartSun HeatLock glass
- Low-E4 Sun glass

For even greater energy performance, 1" (25) triple-pane glass is available in these options:

- Low-E4 glass
- Low-E4 Enhanced glass
- Low-E4 Enhanced HeatLock glass
- Low-E4 SmartSun glass
- Low-E4 SmartSun Enhanced glass
- Low-E4 SmartSun Enhanced HeatLock glass

Tempered and other glass options are available; contact your Andersen supplier.

A removable translucent film helps shield the glass from damage during delivery and construction, and simplifies finishing at the job site.

Patterned Glass

Patterned glass options are available. See page 15 for more details.

Between-the-Glass Art Glass

Available in a variety of original patterns. For details, see page 16 or visit andersenwindows.com/artglass.

PERFORMANCE OPTIONS

Performance Grade (PG) Upgrades

Performance Grade (PG) upgrades are now available for A-Series windows in most sizes of standard non-impact windows allowing these units to achieve higher performance ratings. PG upgrade ratings are more comprehensive than Design Pressure (DP) ratings for measuring product performance. For up-to-date performance information of individual products, visit andersenwindows.com.



A-Series windows available with Stormwatch® Protection include impact-resistant glass in addition to structural upgrades for coastal areas. For a copy of the A-Series Coastal Product Guide, visit andersenwindows.com/coastal.

*Visit andersenwindows.com/warranty for details.

“Flexacron” is a registered trademark of PPG Industries, Inc.

Dimensions in parentheses are in millimeters.

WINDOWS

EXTERIORS & INTERIORS

EXTERIOR COLORS



INTERIOR WOOD SPECIES



FACTORY-FINISHED INTERIORS



All wood interiors are unfinished unless a finish is specified. Clear coat available on all wood species; all other factory finishes on pine, maple and oak. Shown above on pine. Naturally occurring variations in grain, color and texture of wood make each window one of a kind.

INTERIOR PAINT COLORS

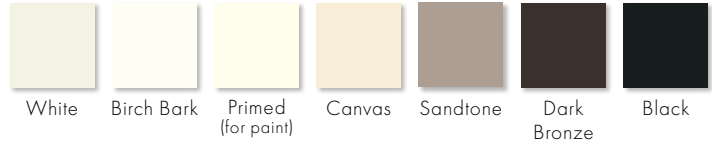

Also available in 11 exterior colors shown above; contact your Andersen supplier. Painted colors on pine or maple.

4-TONE INTERIORS

Mix and match up to four interior wood species, stains and/or colors for your window's frame, sash, grilles and extension jambs to achieve a look unique to your project.

HARDWARE**

Casement, Awning & Venting Transom



CONTEMPORARY FOLDING

Black | Bright Brass | Oil Rubbed Bronze
Satin Nickel | Stone | White



TRADITIONAL FOLDING

Antique Brass | Black | Bright Brass | Distressed Bronze
Distressed Nickel | Oil Rubbed Bronze | Satin Nickel
Stone | White

Folding handles avoid interference with window treatments.
Bold name denotes finish shown.

Double-Hung



Lock & Keeper

Antique Brass | Black | Bright Brass | Distressed Bronze | Distressed Nickel
Oil Rubbed Bronze | **Satin Nickel** | Stone | White



Optional Bar Lift



Optional Hand Lift



Optional Finger Lift

Antique Brass | Black | Bright Brass | Distressed Bronze | Distressed Nickel
Oil Rubbed Bronze | **Satin Nickel** | Stone | White

Bold name denotes finish shown.

HARDWARE FINISHES



*Actual wood species is either Sapele or Sipo, both non-endangered species grown in Africa, with color and characteristics similar to Central American mahoganies.

**Hardware sold separately except double-hung lock and keeper.

Distressed bronze and oil rubbed bronze are "living" finishes that will change with time and use.

Printing limitations prevent exact replication of colors and finishes. See your Andersen supplier for actual color and finish samples.

ACCESSORIES Sold Separately

FRAME

Extension Jamb



Extension jambs are available in pine, maple, vertical grain Douglas fir, oak, mahogany* and cherry, precut to fit the unit. Available in 1/16" (1.5) increments up to 7 1/8" (181) and can be prefinished in six stain colors as well as all interior paint options to match the interior of the unit. This option is also available factory applied.

Stools for Double-Hung Windows

Available in all six wood species and all prefinished options. Stools are available for 4 1/16" (116), 5 1/4" (133), 6 1/16" (167) and 7 1/8" (181) wall depths.

HARDWARE

Corrosion-Resistant Components



Corrosion-resistant hinge and operator arm hardware on casement, awning and venting transom windows is designed for applications in harsh and corrosive environments such as heavy industrial or coastal areas.** Shown on a 400 Series casement window.

Window Opening Control Device



A window opening control device is available for casement and double-hung windows, which limits sash travel to less than 4" (102) when the window is first opened. Available in factory applied, or as a field-applied kit in stone, white and black. Shown on a casement window.

Vent Limiter for Awning & Venting Transom Windows

Available for awning and venting transom windows, which prevents opening the sash more than 4" (102). Available factory applied or as a field-applied kit (part #9184908).

Power Operator for Awning & Venting Transom Windows



Awning windows can be ordered with an operator enhanced by PowerAssist™ technology that opens and closes the window with the touch of a button. Easy to install, the 24-volt system features a concealed window power driver, battery backup in case of a power outage, and a moisture sensor that automatically closes the window when it rains. A wireless remote control is available (sold separately).

The PowerAssist system is controlled by a wall-mounted console, which includes a power box, battery, touch pad and mounting bracket. Power operators are available as field-applied kits. Available for windows up to 5' (1524) wide. Not available for units with Stormwatch® Protection or PG upgrades.

INSECT SCREENS

Full or Half Window Insect Screens

Full insect screens are available for all venting windows. Andersen also offers half insect screens for the lower sash of double-hung windows.

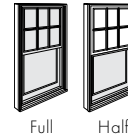

TruScene® Insect Screen



Our TruScene insect screens let in over 25% more fresh air† and provide 50% greater clarity than Andersen conventional insect screens, all while keeping out unwanted small insects. For casement, awning and venting transom windows, frames are available in white, gold dust and stone, as well as prefinished in six wood veneers, six stains and all interior paint options. Insect screens for double-hung windows are installed on the exterior of the window, and frames match the product's exterior color.

Conventional Insect Screens

Aluminum insect screens are available with frames finished in white, gold dust or stone, and in all interior paint options for casement, awning and venting transom windows. Insect screens for double-hung windows match the product's exterior color.

GRILLES

Grilles are available in a variety of configurations and widths. See page 19 for details.

EXTERIOR TRIM

Available with Andersen exterior trim. See the exterior trim section starting on page 189.

*Actual wood species is either Sapele or Sipo, both non-endangered species grown in Africa, with color and characteristics similar to Central American mahogonies.

**Visit andersenwindows.com/warranty for details.

†TruScene insect screens let in over 25% more fresh air than standard Andersen fiberglass insect screens.

Dimensions in parentheses are in millimeters.

CASEMENT WINDOWS

Table of Casement Window Sizes

Scale 1/8" (3) = 1'-0" (305) – 1:96

Window Dimension	1'-7 1/4" (489)	1'-11 1/4" (591)	2'-3 1/4" (692)	2'-5 1/4" (743)	2'-7 1/4" (794)	2'-9 1/4" (845)	2'-11 1/4" (895)	3'-1 1/4" (946)	3'-3 1/4" (997)	3'-5 1/4" (1048)	3'-7 1/4" (1099)	3'-9 1/4" (1149)	3'-11 1/4" (1200)
Minimum Rough Opening	1'-8" (508)	2'-0" (610)	2'-4" (711)	2'-6" (762)	2'-8" (813)	2'-10" (864)	3'-0" (914)	3'-2" (965)	3'-4" (1016)	3'-6" (1067)	3'-8" (1118)	3'-10" (1168)	4'-0" (1219)
Unobstructed Glass	12 5/8" (320)	16 5/8" (422)	20 5/8" (523)	22 5/8" (574)	24 5/8" (625)	26 5/8" (676)	28 5/8" (726)	30 5/8" (777)	32 5/8" (828)	34 5/8" (879)	36 5/8" (930)	38 5/8" (981)	40 5/8" (1032)

CUSTOM SIZES AVAILABLE

CUSTOM SIZES AVAILABLE

1'-11 1/4" (591)													
2'-3 1/4" (692)													
2'-7 1/4" (794)													
2'-11 1/4" (895)													
3'-3 1/4" (997)													
3'-7 1/4" (1099)													
3'-11 1/4" (1200)													
4'-3 1/4" (1302)													
4'-7 1/4" (1403)													
4'-11 1/4" (1505)													
5'-3 1/4" (1607)													

Custom-size windows are available in 1/8" (3) increments. See page 63 for custom sizes and specifications.

Left Right Stationary

Choose left, right or stationary as viewed from the exterior. Most sizes shown are available with PG upgrade.† Grille patterns shown on page 37. Details shown on page 31.

continued on next page

*"Window Dimension" always refers to outside frame-to-frame dimension.
 •"Minimum Rough Opening" dimensions may need to be increased to allow for use of building wraps, flashing, sill panning, brackets, fasteners or other items. See pages 226-227 for more details.
 †Dimensions in parentheses are in millimeters.
 ‡PG upgrade is not available for venting sizes shown with an underscore (i.e. **ACW3844**). PG upgrade is not available for stationary or venting sizes shown with a double underscore (i.e. **ACW2020**).
 †Meets or exceeds clear opening area of 5.7 sq. ft. or 0.53 m², clear opening width of 20" (508) and clear opening height of 24" (610). See tables on pages 28-31.
 †Meets or exceeds clear opening area of 5.7 sq. ft. or 0.53 m², clear opening width of 20" (508) and clear opening height of 24" (610) with a limited sash opening.
 *Hinged for widest clear opening (straight-arm operator). All other sizes have hinge with wash mode (split-arm operator).
 †Not available with triple-pane annealed glass.
 ††Not available with triple-pane annealed or tempered glass.

Table of Casement Window Sizes (continued)

Notes on the previous page also apply to this page.

Scale 1/8" (3) = 1'-0" (305) – 1:96

Window Dimension	1'-7 1/4" (489)	1'-11 1/4" (591)	2'-3 1/4" (692)	2'-5 1/4" (743)	2'-7 1/4" (794)	2'-9 1/4" (845)	2'-11 1/4" (895)	3'-1 1/4" (946)	3'-3 1/4" (997)	3'-5 1/4" (1048)	3'-7 1/4" (1099)	3'-9 1/4" (1149)	3'-11 1/4" (1200)
Minimum Rough Opening	1'-8" (508)	2'-0" (610)	2'-4" (711)	2'-6" (762)	2'-8" (813)	2'-10" (864)	3'-0" (914)	3'-2" (965)	3'-4" (1016)	3'-6" (1067)	3'-8" (1118)	3'-10" (1168)	4'-0" (1219)
Unobstructed Glass	12 5/8" (320)	16 5/8" (422)	20 5/8" (523)	22 5/8" (574)	24 5/8" (625)	26 5/8" (676)	28 5/8" (726)	30 5/8" (777)	32 5/8" (828)	34 5/8" (879)	36 5/8" (930)	38 5/8" (981)	40 5/8" (1032)

CUSTOM SIZES AVAILABLE													
5'-7 1/4" (1708)	ACW1858	ACW2058	ACW2458 ^{0*}	ACW2658 ^{0*}	ACW2858 ⁰	ACW21058 ⁰	ACW3058 ⁰	ACW3258 ^{0††}	ACW3458 ^{0††}	ACW3658 ^{0††}	ACW3858 ^{0††}	ACW31058 ^{0††}	ACW4058 ^{0††}
5'-11 1/4" (1810)	ACW1860	ACW2060	ACW2460 ^{0*}	ACW2660 ^{0*}	ACW2860 ^{0†}	ACW21060 ^{0†}	ACW3060 ^{0†}	ACW3260 ^{0††}	ACW3460 ^{0††}	ACW3660 ^{0††}	ACW3860 ^{0††}	ACW31060 ^{0††}	ACW4060 ^{0††}
6'-3 1/4" (1911)	ACW1864†	ACW2064†	ACW2464 ^{0††}	ACW2664 ^{0††}	ACW2864 ^{0††}	ACW21064 ^{0††}	ACW3064 ^{0††}	ACW3264 ^{0††}	ACW3464 ^{0††}	ACW3664 ^{0††}	ACW3864 ^{0††}	ACW31064 ^{0††}	ACW4064 ^{0††}
6'-7 1/4" (2013)	ACW1868†	ACW2068†	ACW2468 ^{0††}	ACW2668 ^{0††}	ACW2868 ^{0††}	ACW21068 ^{0††}	ACW3068 ^{0††}	ACW3268 ^{0††}	ACW3468 ^{0††}	ACW3668 ^{0††}	ACW3868 ^{0††}	ACW31068 ^{0††}	ACW4068 ^{0††}
6'-11 1/4" (2115)	ACW1870†	ACW2070†	ACW2470 ^{0††}	ACW2670 ^{0††}	ACW2870 ^{0††}	ACW21070 ^{0††}	ACW3070 ^{0††}	ACW3270 ^{0††}	ACW3470 ^{0††}	ACW3670 ^{0††}	ACW3870 ^{0††}	ACW31070 ^{0††}	ACW4070 ^{0††}
7'-3 1/4" (2216)	ACW1874††	ACW2074††	ACW2474 ^{0††}	ACW2674 ^{0††}	ACW2874 ^{0††}	ACW21074 ^{0††}	ACW3074 ^{0††}	ACW3274 ^{0††}	ACW3474 ^{0††}	ACW3674 ^{0††}	ACW3874 ^{0††}	ACW31074 ^{0††}	ACW4074 ^{0††}
7'-7 1/4" (2318)	ACW1878††	ACW2078††	ACW2478 ^{0††}	ACW2678 ^{0††}	ACW2878 ^{0††}	ACW21078 ^{0††}	ACW3078 ^{0††}	ACW3278 ^{0††}	ACW3478 ^{0††}	ACW3678 ^{0††}	ACW3878 ^{0††}	ACW31078 ^{0††}	ACW4078 ^{0††}
7'-11 1/4" (2419)	ACW1880††	ACW2080††	ACW2480 ^{0††}	ACW2680 ^{0††}	ACW2880 ^{0††}	ACW21080 ^{0††}	ACW3080 ^{0††}	ACW3280 ^{0††}	ACW3480 ^{0††}	ACW3680 ^{0††}	ACW3880 ^{0††}	ACW31080 ^{0††}	ACW4080 ^{0††}

A-Series Casement & Awning Windows

CASEMENT WINDOWS

Casement Window Opening and Area Specifications

Window Number	Clear Opening Area Sq. Ft./ (m ²)	Clear Opening in Full Open Position		Glass Area Sq. Ft./ (m ²)	Vent Area Sq. Ft./ (m ²)	Top of Subfloor to Top of Inside Sill Stop Inches/(mm)	Overall Window Area Sq. Ft./ (m ²)
		Width Inches/(mm)	Height Inches/(mm)				
ACW1820	1.20 (0.11)	9 13/16" (250)	17 5/8" (447)	1.38 (0.13)	1.55 (0.14)	62 1/16" (1576)	3.11 (0.29)
ACW1824	1.48 (0.14)	9 13/16" (250)	21 5/8" (549)	1.73 (0.16)	1.91 (0.18)	58 1/16" (1475)	3.64 (0.34)
ACW1828	1.75 (0.16)	9 13/16" (250)	25 5/8" (650)	2.08 (0.19)	2.26 (0.21)	54 1/16" (1373)	4.18 (0.39)
ACW1830	2.02 (0.19)	9 13/16" (250)	29 5/8" (752)	2.43 (0.23)	2.61 (0.24)	50 1/16" (1271)	4.71 (0.44)
ACW1834	2.29 (0.21)	9 13/16" (250)	33 5/8" (853)	2.78 (0.26)	2.97 (0.28)	46 1/16" (1170)	5.25 (0.49)
ACW1838	2.57 (0.24)	9 13/16" (250)	37 5/8" (955)	3.13 (0.29)	3.32 (0.31)	42 1/16" (1068)	5.78 (0.54)
ACW1840	2.84 (0.26)	9 13/16" (250)	41 5/8" (1057)	3.48 (0.32)	3.67 (0.34)	38 1/16" (967)	6.32 (0.59)
ACW1844	3.11 (0.29)	9 13/16" (250)	45 5/8" (1159)	3.83 (0.36)	4.03 (0.37)	34 1/16" (865)	6.85 (0.64)
ACW1848	3.39 (0.31)	9 13/16" (250)	49 5/8" (1260)	4.18 (0.39)	4.38 (0.41)	30 1/16" (763)	7.39 (0.69)
ACW1850	3.66 (0.34)	9 13/16" (250)	53 5/8" (1362)	4.53 (0.42)	4.73 (0.44)	26 1/16" (662)	7.92 (0.74)
ACW1854	3.93 (0.37)	9 13/16" (250)	57 5/8" (1464)	4.88 (0.45)	5.09 (0.47)	22 1/16" (560)	8.46 (0.79)
ACW1858	3.55 (0.33)	8 5/16" (211)	61 5/8" (1565)	5.23 (0.49)	5.44 (0.51)	18 1/16" (459)	8.99 (0.84)
ACW1860	3.78 (0.35)	8 5/16" (211)	65 5/8" (1667)	5.58 (0.52)	5.79 (0.54)	14 1/16" (357)	9.52 (0.88)
ACW1864 †	4.68 (0.43)	9 11/16" (246)	69 5/8" (1768)	5.93 (0.55)	6.15 (0.57)	10 1/16" (256)	10.06 (0.93)
ACW1868 †	4.95 (0.46)	9 11/16" (246)	73 5/8" (1870)	6.28 (0.58)	6.50 (0.60)	6 1/16" (154)	10.59 (0.98)
ACW1870 †	5.22 (0.48)	9 11/16" (246)	77 5/8" (1972)	6.63 (0.62)	6.85 (0.64)	15 9/16" (395)	11.13 (1.03)
ACW1874 ††	5.49 (0.51)	9 11/16" (246)	81 5/8" (2073)	6.98 (0.65)	7.20 (0.67)	11 9/16" (294)	11.66 (1.08)
ACW1878 ††	5.76 (0.54)	9 11/16" (246)	85 5/8" (2175)	7.33 (0.68)	7.56 (0.70)	7 9/16" (192)	12.20 (1.13)
ACW1880 ††	6.03 (0.56)	9 11/16" (246)	89 5/8" (2276)	7.68 (0.71)	7.91 (0.73)	3 9/16" (90)	12.73 (1.18)
ACW2020	1.69 (0.16)	13 13/16" (351)	17 5/8" (447)	1.82 (0.17)	2.04 (0.19)	62 1/16" (1576)	3.75 (0.35)
ACW2024	2.08 (0.19)	13 13/16" (351)	21 5/8" (549)	2.28 (0.21)	2.51 (0.23)	58 1/16" (1475)	4.40 (0.41)
ACW2028	2.46 (0.23)	13 13/16" (351)	25 5/8" (650)	2.74 (0.25)	2.97 (0.28)	54 1/16" (1373)	5.05 (0.47)
ACW2030	2.84 (0.26)	13 13/16" (351)	29 5/8" (752)	3.20 (0.30)	3.44 (0.32)	50 1/16" (1271)	5.69 (0.53)
ACW2034	3.23 (0.30)	13 13/16" (351)	33 5/8" (853)	3.67 (0.34)	3.90 (0.36)	46 1/16" (1170)	6.34 (0.59)
ACW2038	3.61 (0.34)	13 13/16" (351)	37 5/8" (955)	4.13 (0.38)	4.36 (0.41)	42 1/16" (1068)	6.98 (0.65)
ACW2040	4.00 (0.37)	13 13/16" (351)	41 5/8" (1057)	4.59 (0.43)	4.83 (0.45)	38 1/16" (967)	7.63 (0.71)
ACW2044	4.38 (0.41)	13 13/16" (351)	45 5/8" (1159)	5.05 (0.47)	5.29 (0.49)	34 1/16" (865)	8.27 (0.77)
ACW2048	4.24 (0.39)	12 5/16" (313)	49 5/8" (1260)	5.51 (0.51)	5.76 (0.54)	30 1/16" (763)	8.92 (0.83)
ACW2050	4.58 (0.43)	12 5/16" (313)	53 5/8" (1362)	5.97 (0.55)	6.22 (0.58)	26 1/16" (662)	9.57 (0.89)
ACW2054	4.92 (0.46)	12 5/16" (313)	57 5/8" (1464)	6.43 (0.60)	6.69 (0.62)	22 1/16" (560)	10.21 (0.95)
ACW2058	5.26 (0.49)	12 5/16" (313)	61 5/8" (1565)	6.89 (0.64)	7.15 (0.66)	18 1/16" (459)	10.86 (1.01)
ACW2060	5.61 (0.52)	12 5/16" (313)	65 5/8" (1667)	7.35 (0.68)	7.61 (0.71)	14 1/16" (357)	11.50 (1.07)
ACW2064 †	6.52 (0.61)	13 1/2" (343)	69 5/8" (1768)	7.82 (0.73)	8.08 (0.75)	10 1/16" (256)	12.15 (1.13)
ACW2068 †	6.89 (0.64)	13 1/2" (343)	73 5/8" (1870)	8.28 (0.77)	8.54 (0.79)	6 1/16" (154)	12.80 (1.19)
ACW2070 †	7.27 (0.68)	13 1/2" (343)	77 5/8" (1972)	8.74 (0.81)	9.01 (0.84)	15 9/16" (395)	13.44 (1.25)
ACW2074 ††	7.64 (0.71)	13 1/2" (343)	81 5/8" (2073)	9.20 (0.85)	9.47 (0.88)	11 9/16" (294)	14.09 (1.31)
ACW2078 ††	8.02 (0.75)	13 1/2" (343)	85 5/8" (2175)	9.66 (0.90)	9.94 (0.92)	7 9/16" (192)	14.73 (1.37)
ACW2080 ††	8.39 (0.78)	13 1/2" (343)	89 5/8" (2276)	10.12 (0.94)	10.40 (0.97)	3 9/16" (90)	15.38 (1.43)
ACW2420	1.99 (0.18)	16 5/16" (414)	17 5/8" (447)	2.26 (0.21)	2.53 (0.24)	62 1/16" (1576)	4.40 (0.41)
ACW2424	2.45 (0.23)	16 5/16" (414)	21 5/8" (549)	2.83 (0.26)	3.11 (0.29)	58 1/16" (1475)	5.16 (0.48)
ACW2428	2.90 (0.27)	16 5/16" (414)	25 5/8" (650)	3.40 (0.32)	3.68 (0.34)	54 1/16" (1373)	5.91 (0.55)
ACW2430	3.35 (0.31)	16 5/16" (414)	29 5/8" (752)	3.98 (0.37)	4.28 (0.40)	50 1/16" (1271)	6.67 (0.62)
ACW2434	3.80 (0.35)	16 5/16" (414)	33 5/8" (853)	4.55 (0.42)	4.83 (0.45)	46 1/16" (1170)	7.43 (0.69)
ACW2438	4.26 (0.40)	16 5/16" (414)	37 5/8" (955)	5.12 (0.48)	5.41 (0.50)	42 1/16" (1068)	8.18 (0.76)
ACW2440 ◊*	5.92 (0.55)	20 1/2" (521)	41 5/8" (1057)	5.69 (0.53)	5.98 (0.56)	38 1/16" (967)	8.94 (0.83)
ACW2444 ◊*	6.49 (0.60)	20 1/2" (521)	45 5/8" (1159)	6.27 (0.58)	6.56 (0.61)	34 1/16" (865)	9.70 (0.90)
ACW2448 ◊*	7.06 (0.66)	20 1/2" (521)	49 5/8" (1260)	6.84 (0.64)	7.13 (0.66)	30 1/16" (763)	10.46 (0.97)
ACW2450 ◊*	7.63 (0.71)	20 1/2" (521)	53 5/8" (1362)	7.41 (0.69)	7.71 (0.72)	26 1/16" (662)	11.21 (1.04)
ACW2454 ◊*	8.20 (0.76)	20 1/2" (521)	57 5/8" (1464)	7.98 (0.74)	8.29 (0.77)	22 1/16" (560)	11.97 (1.11)
ACW2458 ◊*	8.77 (0.81)	20 1/2" (521)	61 5/8" (1565)	8.55 (0.79)	8.86 (0.82)	18 1/16" (459)	12.73 (1.18)
ACW2460 ◊*	9.34 (0.87)	20 1/2" (521)	65 5/8" (1667)	9.13 (0.85)	9.44 (0.88)	14 1/16" (357)	13.48 (1.25)
ACW2464 ◊††	9.95 (0.92)	20 5/8" (524)	69 5/8" (1768)	9.70 (0.90)	10.01 (0.93)	10 1/16" (256)	14.24 (1.32)
ACW2468 ◊††	10.52 (0.98)	20 5/8" (524)	73 5/8" (1870)	10.27 (0.95)	10.59 (0.98)	6 1/16" (154)	15.00 (1.39)
ACW2470 ◊††	11.09 (1.03)	20 5/8" (524)	77 5/8" (1972)	10.84 (1.01)	11.16 (1.04)	15 9/16" (395)	15.75 (1.46)
ACW2474 ◊††	11.66 (1.08)	20 5/8" (524)	81 5/8" (2073)	11.42 (1.06)	11.74 (1.09)	11 9/16" (294)	16.51 (1.53)
ACW2478 ◊††	12.23 (1.14)	20 5/8" (524)	85 5/8" (2175)	11.99 (1.11)	12.31 (1.14)	7 9/16" (192)	17.27 (1.60)
ACW2480 ◊††	12.80 (1.19)	20 5/8" (524)	89 5/8" (2276)	12.56 (1.17)	12.89 (1.20)	3 9/16" (90)	18.02 (1.67)
ACW2624	2.75 (0.26)	18 5/16" (465)	21 5/8" (549)	3.11 (0.29)	3.41 (0.32)	58 1/16" (1475)	5.54 (0.51)
ACW2628	3.25 (0.30)	18 5/16" (465)	25 5/8" (650)	3.74 (0.35)	4.04 (0.38)	54 1/16" (1373)	6.35 (0.59)
ACW2630	3.76 (0.35)	18 5/16" (465)	29 5/8" (752)	4.36 (0.41)	4.67 (0.43)	50 1/16" (1271)	7.16 (0.67)
ACW2634	4.27 (0.40)	18 5/16" (465)	33 5/8" (853)	4.99 (0.46)	5.30 (0.49)	46 1/16" (1170)	7.97 (0.74)
ACW2638 ◊*	5.88 (0.55)	22 1/2" (572)	37 5/8" (955)	5.62 (0.52)	5.93 (0.55)	42 1/16" (1068)	8.79 (0.82)

*Top of Subfloor to Top of Inside Sill Stop is calculated based upon a structural header height of 6'-10 1/2" (2096).

*Dimensions in parentheses are in millimeters or square meters.

◊Meets or exceeds clear opening area of 5.7 sq. ft. or 0.53 m²; clear opening width of 20" (508) and clear opening height of 24" (610).

†Meets or exceeds clear opening area of 5.7 sq. ft. or 0.53 m²; clear opening width of 20" (508) and clear opening height of 24" (610) with a limited sash opening.

*Hinged for widest clear opening (straight-arm operator). All other sizes have hinge with wash mode (split-arm operator).

†Not available with triple-pane annealed or tempered glass.

continued on next page

Casement Window Opening and Area Specifications *(continued)*

Window Number	Clear Opening Area Sq. Ft./ (m ²)	Clear Opening in Full Open Position		Glass Area Sq. Ft./ (m ²)	Vent Area Sq. Ft./ (m ²)	Top of Subfloor to Top of Inside Sill Stop Inches/(mm)	Overall Window Area Sq. Ft./ (m ²)
		Width Inches/(mm)	Height Inches/(mm)				
ACW2640 ◊*	6.50 (0.60)	22 1/2" (572)	41 5/8" (1057)	6.25 (0.58)	6.56 (0.61)	38 1/16" (967)	9.60 (0.89)
ACW2644 ◊*	7.13 (0.66)	22 1/2" (572)	45 5/8" (1159)	6.87 (0.64)	7.19 (0.67)	34 1/16" (865)	10.41 (0.97)
ACW2648 ◊*	7.75 (0.72)	22 1/2" (572)	49 5/8" (1260)	7.50 (0.70)	7.82 (0.73)	30 1/16" (763)	11.22 (1.04)
ACW2650 ◊*	8.38 (0.78)	22 1/2" (572)	53 5/8" (1362)	8.13 (0.76)	8.45 (0.79)	26 1/16" (662)	12.04 (1.12)
ACW2654 ◊*	9.01 (0.84)	22 1/2" (572)	57 5/8" (1464)	8.76 (0.81)	9.09 (0.84)	22 1/16" (560)	12.85 (1.19)
ACW2658 ◊*	9.63 (0.89)	22 1/2" (572)	61 5/8" (1565)	9.39 (0.87)	9.72 (0.90)	18 1/16" (459)	13.66 (1.27)
ACW2660 ◊*	10.26 (0.95)	22 1/2" (572)	65 5/8" (1667)	10.01 (0.93)	10.35 (0.96)	14 1/16" (357)	14.47 (1.34)
ACW2664 ◊**	10.91 (1.01)	22 5/8" (575)	69 5/8" (1768)	10.64 (0.99)	10.98 (1.02)	10 1/16" (256)	15.29 (1.42)
ACW2668 ◊**	11.54 (1.07)	22 5/8" (575)	73 5/8" (1870)	11.27 (1.05)	11.61 (1.08)	6 1/16" (154)	16.10 (1.50)
ACW2670 ◊**	12.17 (1.13)	22 5/8" (575)	77 5/8" (1972)	11.90 (1.11)	12.24 (1.14)	15 9/16" (395)	16.91 (1.57)
ACW2674 ◊**†	12.79 (1.19)	22 5/8" (575)	81 5/8" (2073)	12.52 (1.16)	12.87 (1.20)	11 9/16" (294)	17.72 (1.65)
ACW2678 ◊**†	13.42 (1.25)	22 5/8" (575)	85 5/8" (2175)	13.15 (1.22)	13.50 (1.25)	7 9/16" (192)	18.54 (1.72)
ACW2680 ◊**†	14.05 (1.31)	22 5/8" (575)	89 5/8" (2276)	13.78 (1.28)	14.13 (1.31)	3 9/16" (90)	19.35 (1.80)
ACW2824	3.05 (0.28)	20 5/16" (516)	21 5/8" (549)	3.38 (0.31)	3.71 (0.34)	58 1/16" (1475)	5.91 (0.55)
ACW2828	3.61 (0.34)	20 5/16" (516)	25 5/8" (650)	4.07 (0.38)	4.39 (0.41)	54 1/16" (1373)	6.78 (0.63)
ACW2830	4.17 (0.39)	20 5/16" (516)	29 5/8" (752)	4.75 (0.44)	5.08 (0.47)	50 1/16" (1271)	7.65 (0.71)
ACW2834	4.74 (0.44)	20 5/16" (516)	33 5/8" (853)	5.43 (0.50)	5.77 (0.54)	46 1/16" (1170)	8.52 (0.79)
ACW2838 ◊*	6.40 (0.59)	24 1/2" (623)	37 5/8" (955)	6.12 (0.57)	6.45 (0.60)	42 1/16" (1068)	9.39 (0.87)
ACW2840 ◊	5.87 (0.55)	20 5/16" (516)	41 5/8" (1057)	6.80 (0.63)	7.14 (0.66)	38 1/16" (967)	10.25 (0.95)
ACW2844 ◊	6.43 (0.60)	20 5/16" (516)	45 5/8" (1159)	7.48 (0.69)	7.83 (0.73)	34 1/16" (865)	11.12 (1.03)
ACW2848 ◊	6.99 (0.65)	20 5/16" (516)	49 5/8" (1260)	8.17 (0.76)	8.51 (0.79)	30 1/16" (763)	11.99 (1.11)
ACW2850 ◊	7.56 (0.70)	20 5/16" (516)	53 5/8" (1362)	8.85 (0.82)	9.20 (0.85)	26 1/16" (662)	12.86 (1.19)
ACW2854 ◊	9.44 (0.88)	23 19/32" (599)	57 5/8" (1464)	9.53 (0.89)	9.89 (0.92)	22 1/16" (560)	13.73 (1.28)
ACW2858 ◊	10.09 (0.94)	23 19/32" (599)	61 5/8" (1565)	10.22 (0.95)	10.57 (0.98)	18 1/16" (459)	14.59 (1.36)
ACW2860 ◊†	10.75 (1.00)	23 19/32" (599)	65 5/8" (1667)	10.90 (1.01)	11.26 (1.05)	14 1/16" (357)	15.46 (1.44)
ACW2864 ◊**	9.95 (0.92)	20 9/16" (522)	69 5/8" (1768)	11.58 (1.08)	11.95 (1.11)	10 1/16" (256)	16.33 (1.52)
ACW2868 ◊**	10.52 (0.98)	20 9/16" (522)	73 5/8" (1870)	12.27 (1.14)	12.63 (1.17)	6 1/16" (154)	17.20 (1.60)
ACW2870 ◊**	11.09 (1.03)	20 9/16" (522)	77 5/8" (1972)	12.95 (1.20)	13.32 (1.24)	15 9/16" (395)	18.07 (1.68)
ACW2874 ◊**†	11.66 (1.08)	20 9/16" (522)	81 5/8" (2073)	13.63 (1.27)	14.00 (1.30)	11 9/16" (294)	18.93 (1.76)
ACW2878 ◊**†	12.23 (1.14)	20 9/16" (522)	85 5/8" (2175)	14.32 (1.33)	14.69 (1.36)	7 9/16" (192)	19.80 (1.84)
ACW2880 ◊**†	12.81 (1.19)	20 9/16" (522)	89 5/8" (2276)	15.00 (1.39)	15.38 (1.43)	3 9/16" (90)	20.67 (1.92)
ACW21028	3.97 (0.37)	22 5/16" (567)	25 5/8" (650)	4.40 (0.41)	4.75 (0.44)	54 1/16" (1373)	7.22 (0.67)
ACW21030	4.58 (0.43)	22 5/16" (567)	29 5/8" (752)	5.14 (0.48)	5.49 (0.51)	50 1/16" (1271)	8.14 (0.76)
ACW21034	5.20 (0.48)	22 5/16" (567)	33 5/8" (853)	5.87 (0.55)	6.23 (0.58)	46 1/16" (1170)	9.06 (0.84)
ACW21038 ◊	5.82 (0.54)	22 5/16" (567)	37 5/8" (955)	6.61 (0.61)	6.98 (0.65)	42 1/16" (1068)	9.99 (0.93)
ACW21040 ◊	6.44 (0.60)	22 5/16" (567)	41 5/8" (1057)	7.35 (0.68)	7.72 (0.72)	38 1/16" (967)	10.91 (1.01)
ACW21044 ◊	7.06 (0.66)	22 5/16" (567)	45 5/8" (1159)	8.09 (0.75)	8.46 (0.79)	34 1/16" (865)	11.83 (1.10)
ACW21048 ◊	8.78 (0.82)	25 1/2" (648)	49 5/8" (1260)	8.83 (0.82)	9.20 (0.85)	30 1/16" (763)	12.76 (1.19)
ACW21050 ◊	9.49 (0.88)	25 1/2" (648)	53 5/8" (1362)	9.57 (0.89)	9.94 (0.92)	26 1/16" (662)	13.68 (1.27)
ACW21054 ◊	10.20 (0.95)	25 1/2" (648)	57 5/8" (1464)	10.31 (0.96)	10.69 (0.99)	22 1/16" (560)	14.60 (1.36)
ACW21058 ◊	10.91 (1.01)	25 1/2" (648)	61 5/8" (1565)	11.05 (1.03)	11.43 (1.06)	18 1/16" (459)	15.53 (1.44)
ACW21060 ◊†	11.61 (1.08)	25 1/2" (648)	65 5/8" (1667)	11.79 (1.10)	12.17 (1.13)	14 1/16" (357)	16.45 (1.53)
ACW21064 ◊**†	10.71 (0.99)	22 1/8" (562)	69 5/8" (1768)	12.52 (1.16)	12.91 (1.20)	10 1/16" (256)	17.38 (1.61)
ACW21068 ◊**†	11.32 (1.05)	22 1/8" (562)	73 5/8" (1870)	13.26 (1.23)	13.65 (1.27)	6 1/16" (154)	18.30 (1.70)
ACW21070 ◊**†	11.94 (1.11)	22 1/8" (562)	77 5/8" (1972)	14.00 (1.30)	14.40 (1.34)	15 9/16" (395)	19.22 (1.79)
ACW21074 ◊**††	12.56 (1.17)	22 1/8" (562)	81 5/8" (2073)	14.74 (1.37)	15.14 (1.41)	11 9/16" (294)	20.15 (1.87)
ACW21078 ◊**††	13.17 (1.22)	22 1/8" (562)	85 5/8" (2175)	15.48 (1.44)	15.88 (1.48)	7 9/16" (192)	21.07 (1.96)
ACW21080 ◊**††	13.77 (1.28)	22 1/8" (562)	89 5/8" (2276)	16.22 (1.51)	16.62 (1.54)	3 9/16" (90)	21.99 (2.04)
ACW3028	4.32 (0.40)	24 5/16" (617)	25 5/8" (650)	4.73 (0.44)	5.10 (0.47)	54 1/16" (1373)	7.65 (0.71)
ACW3030	5.00 (0.46)	24 5/16" (617)	29 5/8" (752)	5.52 (0.51)	5.90 (0.55)	50 1/16" (1271)	8.63 (0.80)
ACW3034	5.67 (0.53)	24 5/16" (617)	33 5/8" (853)	6.32 (0.59)	6.70 (0.62)	46 1/16" (1170)	9.61 (0.89)
ACW3038 ◊	6.35 (0.59)	24 5/16" (617)	37 5/8" (955)	7.11 (0.66)	7.50 (0.70)	42 1/16" (1068)	10.59 (0.98)
ACW3040 ◊	7.91 (0.73)	27 1/16" (696)	41 5/8" (1057)	7.90 (0.73)	8.30 (0.77)	38 1/16" (967)	11.57 (1.07)
ACW3044 ◊	8.68 (0.81)	27 1/16" (696)	45 5/8" (1159)	8.70 (0.81)	9.09 (0.84)	34 1/16" (865)	12.55 (1.17)
ACW3048 ◊	9.44 (0.88)	27 1/16" (696)	49 5/8" (1260)	9.49 (0.88)	9.89 (0.92)	30 1/16" (763)	13.52 (1.26)
ACW3050 ◊	10.20 (0.95)	27 1/16" (696)	53 5/8" (1362)	10.29 (0.96)	10.69 (0.99)	26 1/16" (662)	14.50 (1.35)
ACW3054 ◊	10.96 (1.02)	27 1/16" (696)	57 5/8" (1464)	11.08 (1.03)	11.49 (1.07)	22 1/16" (560)	15.48 (1.44)
ACW3058 ◊	11.72 (1.09)	27 1/16" (696)	61 5/8" (1565)	11.88 (1.10)	12.28 (1.14)	18 1/16" (459)	16.46 (1.53)
ACW3060 ◊†	12.48 (1.16)	27 1/16" (696)	65 5/8" (1667)	12.67 (1.18)	13.08 (1.22)	14 1/16" (357)	17.44 (1.62)
ACW3064 ◊**†	10.77 (1.00)	22 1/4" (565)	69 5/8" (1768)	13.47 (1.25)	13.88 (1.29)	10 1/16" (256)	18.42 (1.71)
ACW3068 ◊**†	11.39 (1.06)	22 1/4" (565)	73 5/8" (1870)	14.26 (1.32)	14.68 (1.36)	6 1/16" (154)	19.40 (1.80)
ACW3070 ◊**†	12.01 (1.12)	22 1/4" (565)	77 5/8" (1972)	15.05 (1.40)	15.47 (1.44)	15 9/16" (395)	20.38 (1.89)

* "Top of Subfloor to Top of Inside Sill Stop" is calculated based upon a structural header height of 6'-10 1/2" (2096).
 † Dimensions in parentheses are in millimeters or square meters.
 ◊ Meets or exceeds clear opening area of 5.7 sq. ft. or 0.53 m², clear opening width of 20" (508) and clear opening height of 24" (610).
 † Meets or exceeds clear opening area of 5.7 sq. ft. or 0.53 m², clear opening width of 20" (508) and clear opening height of 24" (610) with a limited sash opening.
 * Hinged for widest clear opening (straight-arm operator). All other sizes have hinge with wash mode (split-arm operator).
 † Not available with triple-pane annealed glass.
 †† Not available with triple-pane annealed or tempered glass.

continued on next page

CASEMENT WINDOWS

Casement Window Opening and Area Specifications (continued)

Window Number	Clear Opening Area Sq. Ft./ (m ²)	Clear Opening in Full Open Position		Glass Area Sq. Ft./ (m ²)	Vent Area Sq. Ft./ (m ²)	Top of Subfloor to Top of Inside Sill Stop Inches/ (mm)	Overall Window Area Sq. Ft./ (m ²)
		Width Inches/ (mm)	Height Inches/ (mm)				
ACW3074 ♦♦††	12.63 (1.17)	22 1/4" (565)	81 5/8" (2073)	15.85 (1.47)	16.27 (1.51)	11 9/16" (294)	21.36 (1.98)
ACW3078 ♦♦††	13.25 (1.23)	22 1/4" (565)	85 5/8" (2175)	16.64 (1.55)	17.07 (1.59)	7 9/16" (192)	22.34 (2.08)
ACW3080 ♦♦††	13.87 (1.29)	22 1/4" (565)	89 5/8" (2276)	17.44 (1.62)	17.87 (1.66)	3 9/16" (90)	23.32 (2.17)
ACW3230*†	4.78 (0.44)	23 1/4" (591)	29 5/8" (752)	5.91 (0.55)	6.31 (0.59)	50 1/16" (1271)	9.12 (0.85)
ACW3234*†	5.43 (0.50)	23 1/4" (591)	33 5/8" (853)	6.76 (0.63)	7.17 (0.67)	46 1/16" (1170)	10.15 (0.94)
ACW3238 ♦♦†	6.07 (0.56)	23 1/4" (591)	37 5/8" (955)	7.61 (0.71)	8.02 (0.75)	42 1/16" (1068)	11.19 (1.04)
ACW3240 ♦♦†	6.72 (0.62)	23 1/4" (591)	41 5/8" (1057)	8.46 (0.79)	8.87 (0.82)	38 1/16" (967)	12.22 (1.14)
ACW3244 ♦♦†	7.36 (0.68)	23 1/4" (591)	45 5/8" (1159)	9.31 (0.86)	9.73 (0.90)	34 1/16" (865)	13.26 (1.23)
ACW3248 ♦♦†	8.01 (0.74)	23 1/4" (591)	49 5/8" (1260)	10.16 (0.94)	10.58 (0.98)	30 1/16" (763)	14.29 (1.33)
ACW3250 ♦♦†	8.65 (0.80)	23 1/4" (591)	53 5/8" (1362)	11.01 (1.02)	11.43 (1.06)	26 1/16" (662)	15.33 (1.42)
ACW3254 ♦♦†	9.30 (0.86)	23 1/4" (591)	57 5/8" (1464)	11.86 (1.10)	12.29 (1.14)	22 1/16" (560)	16.36 (1.52)
ACW3258 ♦♦†	9.95 (0.92)	23 1/4" (591)	61 5/8" (1565)	12.71 (1.18)	13.14 (1.22)	18 1/16" (459)	17.40 (1.62)
ACW3260 ♦♦†	10.59 (0.98)	23 1/4" (591)	65 5/8" (1667)	13.56 (1.26)	13.99 (1.30)	14 1/16" (357)	18.43 (1.71)
ACW3264 ♦♦†	11.24 (1.04)	23 1/4" (591)	69 5/8" (1768)	14.41 (1.34)	14.85 (1.38)	10 1/16" (256)	19.47 (1.81)
ACW3268 ♦♦†	11.88 (1.10)	23 1/4" (591)	73 5/8" (1870)	15.26 (1.42)	15.70 (1.46)	6 1/16" (154)	20.50 (1.90)
ACW3270 ♦♦†	12.53 (1.16)	23 1/4" (591)	77 5/8" (1972)	16.11 (1.50)	16.55 (1.54)	15 9/16" (395)	21.54 (2.00)
ACW3274 ♦♦††	13.18 (1.22)	23 1/4" (591)	81 5/8" (2073)	16.96 (1.58)	17.40 (1.62)	11 9/16" (294)	22.57 (2.10)
ACW3278 ♦♦††	13.82 (1.28)	23 1/4" (591)	85 5/8" (2175)	17.81 (1.65)	18.26 (1.70)	7 9/16" (192)	23.60 (2.19)
ACW3280 ♦♦††	14.47 (1.34)	23 1/4" (591)	89 5/8" (2276)	18.66 (1.73)	19.11 (1.78)	3 9/16" (90)	24.64 (2.29)
ACW3430*†	4.72 (0.44)	23" (584)	29 5/8" (752)	6.29 (0.58)	6.72 (0.62)	50 1/16" (1271)	9.61 (0.89)
ACW3434*†	5.36 (0.50)	23" (584)	33 5/8" (853)	7.20 (0.67)	7.63 (0.71)	46 1/16" (1170)	10.70 (0.99)
ACW3438 ♦♦†	6.00 (0.56)	23" (584)	37 5/8" (955)	8.10 (0.75)	8.54 (0.79)	42 1/16" (1068)	11.79 (1.10)
ACW3440 ♦♦†	6.64 (0.62)	23" (584)	41 5/8" (1057)	9.01 (0.84)	9.45 (0.88)	38 1/16" (967)	12.88 (1.20)
ACW3444 ♦♦†	7.27 (0.68)	23" (584)	45 5/8" (1159)	9.92 (0.92)	10.36 (0.96)	34 1/16" (865)	13.97 (1.30)
ACW3448 ♦♦†	7.91 (0.73)	23" (584)	49 5/8" (1260)	10.82 (1.01)	11.27 (1.05)	30 1/16" (763)	15.06 (1.40)
ACW3450 ♦♦†	8.55 (0.79)	23" (584)	53 5/8" (1362)	11.73 (1.09)	12.18 (1.13)	26 1/16" (662)	16.15 (1.50)
ACW3454 ♦♦†	9.19 (0.85)	23" (584)	57 5/8" (1464)	12.63 (1.17)	13.09 (1.22)	22 1/16" (560)	17.24 (1.60)
ACW3458 ♦♦†	9.83 (0.91)	23" (584)	61 5/8" (1565)	13.54 (1.26)	13.99 (1.30)	18 1/16" (459)	18.33 (1.70)
ACW3460 ♦♦†	10.46 (0.97)	23" (584)	65 5/8" (1667)	14.44 (1.34)	14.90 (1.38)	14 1/16" (357)	19.42 (1.80)
ACW3464 ♦♦†	11.10 (1.03)	23" (584)	69 5/8" (1768)	15.35 (1.43)	15.81 (1.47)	10 1/16" (256)	20.51 (1.91)
ACW3468 ♦♦†	11.74 (1.09)	23" (584)	73 5/8" (1870)	16.25 (1.51)	16.72 (1.55)	6 1/16" (154)	21.60 (2.01)
ACW3470 ♦♦†	12.38 (1.15)	23" (584)	77 5/8" (1972)	17.16 (1.59)	17.63 (1.64)	15 9/16" (395)	22.69 (2.11)
ACW3474 ♦♦††	13.02 (1.21)	23" (584)	81 5/8" (2073)	18.07 (1.68)	18.54 (1.72)	11 9/16" (294)	23.78 (2.21)
ACW3478 ♦♦††	13.66 (1.27)	23" (584)	85 5/8" (2175)	18.97 (1.76)	19.45 (1.81)	7 9/16" (192)	24.87 (2.31)
ACW3480 ♦♦††	14.29 (1.33)	23" (584)	89 5/8" (2276)	19.88 (1.85)	20.36 (1.89)	3 9/16" (90)	25.96 (2.41)
ACW3634*†	5.27 (0.49)	22 9/16" (573)	33 5/8" (853)	7.64 (0.71)	8.10 (0.75)	46 1/16" (1170)	11.24 (1.04)
ACW3638 ♦♦†	5.90 (0.55)	22 9/16" (573)	37 5/8" (955)	8.60 (0.80)	9.06 (0.84)	42 1/16" (1068)	12.39 (1.15)
ACW3640 ♦♦†	6.53 (0.61)	22 9/16" (573)	41 5/8" (1057)	9.56 (0.89)	10.03 (0.93)	38 1/16" (967)	13.54 (1.26)
ACW3644 ♦♦†	7.15 (0.66)	22 9/16" (573)	45 5/8" (1159)	10.52 (0.98)	10.99 (1.02)	34 1/16" (865)	14.68 (1.36)
ACW3648 ♦♦†	7.78 (0.72)	22 9/16" (573)	49 5/8" (1260)	11.49 (1.07)	11.96 (1.11)	30 1/16" (763)	15.83 (1.47)
ACW3650 ♦♦†	8.41 (0.78)	22 9/16" (573)	53 5/8" (1362)	12.45 (1.16)	12.92 (1.20)	26 1/16" (662)	16.97 (1.58)
ACW3654 ♦♦†	9.03 (0.84)	22 9/16" (573)	57 5/8" (1464)	13.41 (1.25)	13.89 (1.29)	22 1/16" (560)	18.12 (1.68)
ACW3658 ♦♦†	9.66 (0.90)	22 9/16" (573)	61 5/8" (1565)	14.37 (1.34)	14.85 (1.38)	18 1/16" (459)	19.26 (1.79)
ACW3660 ♦♦†	10.29 (0.96)	22 9/16" (573)	65 5/8" (1667)	15.33 (1.42)	15.81 (1.47)	14 1/16" (357)	20.41 (1.90)
ACW3664 ♦♦†	10.92 (1.01)	22 9/16" (573)	69 5/8" (1768)	16.29 (1.51)	16.78 (1.56)	10 1/16" (256)	21.56 (2.00)
ACW3668 ♦♦†	11.54 (1.07)	22 9/16" (573)	73 5/8" (1870)	17.25 (1.60)	17.74 (1.65)	6 1/16" (154)	22.70 (2.11)
ACW3670 ♦♦†	12.17 (1.13)	22 9/16" (573)	77 5/8" (1972)	18.21 (1.69)	18.71 (1.74)	15 9/16" (395)	23.85 (2.22)
ACW3674 ♦♦††	12.80 (1.19)	22 9/16" (573)	81 5/8" (2073)	19.17 (1.78)	19.67 (1.83)	11 9/16" (294)	24.99 (2.32)
ACW3678 ♦♦††	13.43 (1.25)	22 9/16" (573)	85 5/8" (2175)	20.14 (1.87)	20.64 (1.92)	7 9/16" (192)	26.14 (2.43)
ACW3680 ♦♦††	14.05 (1.31)	22 9/16" (573)	89 5/8" (2276)	21.10 (1.96)	21.60 (2.01)	3 9/16" (90)	27.29 (2.54)
ACW3834*††	5.18 (0.48)	22 1/4" (565)	33 5/8" (853)	8.08 (0.75)	8.57 (0.80)	46 1/16" (1170)	11.79 (1.10)
ACW3838 ♦♦††	5.80 (0.54)	22 1/4" (565)	37 5/8" (955)	9.10 (0.85)	9.59 (0.89)	42 1/16" (1068)	12.99 (1.21)
ACW3840 ♦♦††	6.42 (0.60)	22 1/4" (565)	41 5/8" (1057)	10.12 (0.94)	10.61 (0.99)	38 1/16" (967)	14.19 (1.32)
ACW3844 ♦♦††	7.04 (0.65)	22 1/4" (565)	45 5/8" (1159)	11.13 (1.03)	11.63 (1.08)	34 1/16" (865)	15.39 (1.43)
ACW3848 ♦♦††	7.65 (0.71)	22 1/4" (565)	49 5/8" (1260)	12.15 (1.13)	12.65 (1.18)	30 1/16" (763)	16.59 (1.54)
ACW3850 ♦♦††	8.27 (0.77)	22 1/4" (565)	53 5/8" (1362)	13.17 (1.22)	13.67 (1.27)	26 1/16" (662)	17.80 (1.65)
ACW3854 ♦♦††	8.89 (0.83)	22 1/4" (565)	57 5/8" (1464)	14.18 (1.32)	14.69 (1.36)	22 1/16" (560)	19.00 (1.77)
ACW3858 ♦♦††	9.50 (0.88)	22 1/4" (565)	61 5/8" (1565)	15.20 (1.41)	15.71 (1.46)	18 1/16" (459)	20.20 (1.88)
ACW3860 ♦♦†	10.12 (0.94)	22 1/4" (565)	65 5/8" (1667)	16.22 (1.51)	16.73 (1.55)	14 1/16" (357)	21.40 (1.99)
ACW3864 ♦♦†	10.74 (1.00)	22 1/4" (565)	69 5/8" (1768)	17.23 (1.60)	17.75 (1.65)	10 1/16" (256)	22.60 (2.10)
ACW3868 ♦♦†	11.36 (1.06)	22 1/4" (565)	73 5/8" (1870)	18.25 (1.70)	18.76 (1.74)	6 1/16" (154)	23.80 (2.21)
ACW3870 ♦♦†	11.97 (1.11)	22 1/4" (565)	77 5/8" (1972)	19.27 (1.79)	19.78 (1.84)	15 9/16" (395)	25.00 (2.32)

*Top of Subfloor to Top of Inside Sill Stop" is calculated based upon a structural header height of 6'-10 1/2" (2096).
 *Dimensions in parentheses are in millimeters or square meters.
 ♦Meets or exceeds clear opening area of 5.7 sq. ft. or 0.53 m², clear opening width of 20" (508) and clear opening height of 24" (610) with a limited *Hinged for widest clear opening (straight-arm operator). All other sizes have hinge with wash mode (split-arm operator).
 †Not available with triple-pane annealed glass.
 ††Not available with triple-pane annealed or tempered glass.

Casement Window Opening and Area Specifications (continued)

Window Number	Clear Opening Area Sq. Ft./ (m ²)	Clear Opening in Full Open Position		Glass Area Sq. Ft./ (m ²)	Vent Area Sq. Ft./ (m ²)	Top of Subfloor to Top of Inside Sill Stop Inches/(mm)	Overall Window Area Sq. Ft./ (m ²)
		Width Inches/(mm)	Height Inches/(mm)				
ACW3874 ♦♦††	12.59 (1.17)	22 1/4" (565)	81 5/8" (2073)	20.28 (1.88)	20.80 (1.93)	11 9/16" (294)	26.21 (2.43)
ACW3878 ♦♦††	13.21 (1.23)	22 1/4" (565)	85 5/8" (2175)	21.30 (1.98)	21.82 (2.03)	7 9/16" (192)	27.41 (2.55)
ACW3880 ♦♦††	13.82 (1.28)	22 1/4" (565)	89 5/8" (2276)	22.32 (2.07)	22.84 (2.12)	3 9/16" (90)	28.61 (2.66)
ACW31038 ♦♦††	5.68 (0.53)	21 3/4" (552)	37 5/8" (955)	9.60 (0.89)	10.11 (0.94)	42 1/16" (1068)	13.59 (1.26)
ACW31040 ♦♦††	6.28 (0.58)	21 3/4" (552)	41 5/8" (1057)	10.67 (0.99)	11.18 (1.04)	38 1/16" (967)	14.85 (1.38)
ACW31044 ♦♦††	6.89 (0.64)	21 3/4" (552)	45 5/8" (1159)	11.74 (1.09)	12.26 (1.14)	34 1/16" (865)	16.10 (1.50)
ACW31048 ♦♦††	7.49 (0.70)	21 3/4" (552)	49 5/8" (1260)	12.81 (1.19)	13.33 (1.24)	30 1/16" (763)	17.36 (1.61)
ACW31050 ♦♦††	8.09 (0.75)	21 3/4" (552)	53 5/8" (1362)	13.89 (1.29)	14.41 (1.34)	26 1/16" (662)	18.62 (1.73)
ACW31054 ♦♦††	8.70 (0.81)	21 3/4" (552)	57 5/8" (1464)	14.96 (1.39)	15.49 (1.44)	22 1/16" (560)	19.88 (1.85)
ACW31058 ♦♦††	9.30 (0.86)	21 3/4" (552)	61 5/8" (1565)	16.03 (1.49)	16.56 (1.54)	18 1/16" (459)	21.13 (1.96)
ACW31060 ♦♦†	9.91 (0.92)	21 3/4" (552)	65 5/8" (1667)	17.10 (1.59)	17.64 (1.64)	14 1/16" (357)	22.39 (2.08)
ACW31064 ♦♦†	10.51 (0.98)	21 3/4" (552)	69 5/8" (1768)	18.17 (1.69)	18.71 (1.74)	10 1/16" (256)	23.65 (2.20)
ACW31068 ♦♦†	11.11 (1.03)	21 3/4" (552)	73 5/8" (1870)	19.25 (1.79)	19.79 (1.84)	6 1/16" (154)	24.90 (2.31)
ACW31070 ♦♦†	11.72 (1.09)	21 3/4" (552)	77 5/8" (1972)	20.32 (1.89)	20.86 (1.94)	15 9/16" (395)	26.16 (2.43)
ACW31074 ♦♦††	12.32 (1.14)	21 3/4" (552)	81 5/8" (2073)	21.39 (1.99)	21.94 (2.04)	11 9/16" (294)	27.42 (2.55)
ACW31078 ♦♦††	12.93 (1.20)	21 3/4" (552)	85 5/8" (2175)	22.46 (2.09)	23.01 (2.14)	7 9/16" (192)	28.67 (2.66)
ACW31080 ♦♦††	13.53 (1.26)	21 3/4" (552)	89 5/8" (2276)	23.54 (2.19)	24.09 (2.24)	3 9/16" (90)	29.93 (2.78)
ACW4038 ♦♦††	5.53 (0.51)	21 3/16" (538)	37 5/8" (955)	10.09 (0.94)	10.63 (0.99)	42 1/16" (1068)	14.19 (1.32)
ACW4040 ♦♦††	6.12 (0.57)	21 3/16" (538)	41 5/8" (1057)	11.22 (1.04)	11.76 (1.09)	38 1/16" (967)	15.50 (1.44)
ACW4044 ♦♦††	6.71 (0.62)	21 3/16" (538)	45 5/8" (1159)	12.35 (1.15)	12.89 (1.20)	34 1/16" (865)	16.82 (1.56)
ACW4048 ♦♦††	7.30 (0.68)	21 3/16" (538)	49 5/8" (1260)	13.48 (1.25)	14.02 (1.30)	30 1/16" (763)	18.13 (1.68)
ACW4050 ♦♦††	7.89 (0.73)	21 3/16" (538)	53 5/8" (1362)	14.60 (1.36)	15.15 (1.41)	26 1/16" (662)	19.44 (1.81)
ACW4054 ♦♦††	8.48 (0.79)	21 3/16" (538)	57 5/8" (1464)	15.73 (1.46)	16.29 (1.51)	22 1/16" (560)	20.75 (1.93)
ACW4058 ♦♦††	9.07 (0.84)	21 3/16" (538)	61 5/8" (1565)	16.86 (1.57)	17.42 (1.62)	18 1/16" (459)	22.07 (2.05)
ACW4060 ♦♦†	9.66 (0.90)	21 3/16" (538)	65 5/8" (1667)	17.99 (1.67)	18.55 (1.72)	14 1/16" (357)	23.38 (2.17)
ACW4064 ♦♦†	10.24 (0.95)	21 3/16" (538)	69 5/8" (1768)	19.12 (1.78)	19.68 (1.83)	10 1/16" (256)	24.69 (2.29)
ACW4068 ♦♦†	10.83 (1.01)	21 3/16" (538)	73 5/8" (1870)	20.24 (1.88)	20.81 (1.93)	6 1/16" (154)	26.00 (2.42)
ACW4070 ♦♦†	11.42 (1.06)	21 3/16" (538)	77 5/8" (1972)	21.37 (1.99)	21.94 (2.04)	15 9/16" (395)	27.32 (2.54)
ACW4074 ♦♦††	12.01 (1.12)	21 3/16" (538)	81 5/8" (2073)	22.50 (2.09)	23.07 (2.14)	11 9/16" (294)	28.63 (2.66)
ACW4078 ♦♦††	12.60 (1.17)	21 3/16" (538)	85 5/8" (2175)	23.63 (2.20)	24.20 (2.25)	7 9/16" (192)	29.94 (2.78)
ACW4080 ♦♦††	13.19 (1.23)	21 3/16" (538)	89 5/8" (2276)	24.75 (2.30)	25.33 (2.35)	3 9/16" (90)	31.25 (2.90)

• "Top of Subfloor to Top of Inside Sill Stop" is calculated based upon a structural header height of 6'-10 1/2" (2096).
 • Dimensions in parentheses are in millimeters or square meters.
 ♦ Meets or exceeds clear opening area of 5.7 sq. ft. or 0.53 m², clear opening width of 20" (508) and clear opening height of 24" (610) with a limited sash opening.
 * Hinged for widest clear opening (straight-arm operator). All other sizes have hinge with wash mode (split-arm operator).
 † Not available with triple-pane annealed glass.
 †† Not available with triple-pane annealed or tempered glass.

A-Series Casement & Awning Windows

Casement Window Details

Scale 1 1/2" (38) = 1'-0" (305) – 1:8

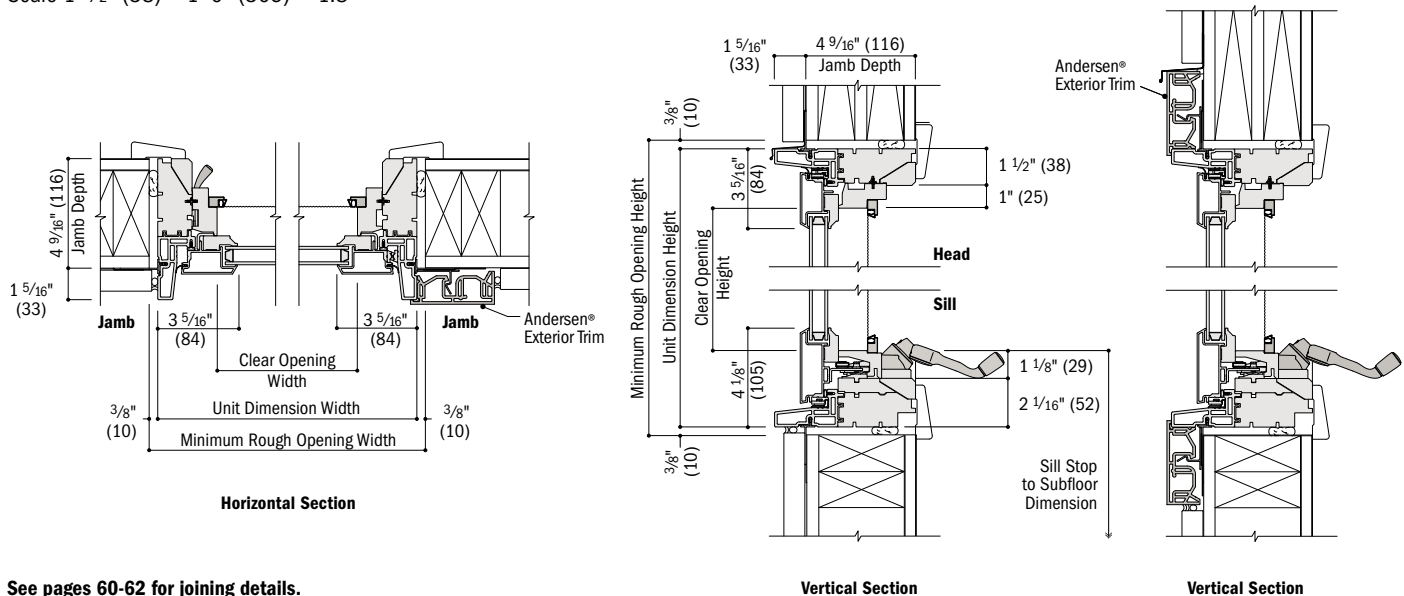

See pages 60-62 for joining details.

- 4 9/16" (116) base jamb depth measurement is from back side of installation flange.
- Light-colored areas are parts included with window. Dark-colored areas are additional Andersen® parts required to complete window assembly as shown.
- Dimensions in parentheses are in millimeters.
- Minimum rough openings may need to be increased to allow for use of building wraps, flashing, sill panning, brackets, fasteners or other items. See installation information on pages 226-227.
- Details are for illustration only and are not intended to represent product installation methods or materials. Refer to product installation instructions at andersenwindows.com.

AWNING WINDOWS

Table of Awning Window Sizes

Scale 1/8" (3) = 1'-0" (305) – 1:96

Window Dimension	1'-7 1/4"	1'-11 1/4"	2'-3 1/4"	2'-5 1/4"	2'-7 1/4"	2'-9 1/4"	2'-11 1/4"	3'-1 1/4"	3'-3 1/4"	3'-7 1/4"	3'-11 1/4"	4'-3 1/4"
	(489)	(591)	(692)	(743)	(794)	(845)	(895)	(946)	(997)	(1099)	(1200)	(1302)
Minimum Rough Opening	1'-8"	2'-0"	2'-4"	2'-6"	2'-8"	2'-10"	3'-0"	3'-2"	3'-4"	3'-8"	4'-0"	4'-4"
	(508)	(610)	(711)	(762)	(813)	(864)	(914)	(965)	(1016)	(1118)	(1219)	(1321)
Unobstructed Glass	12 5/8"	16 5/8"	20 5/8"	22 5/8"	24 5/8"	26 5/8"	28 5/8"	30 5/8"	32 5/8"	36 5/8"	40 5/8"	44 5/8"
	(320)	(422)	(523)	(574)	(625)	(676)	(726)	(777)	(828)	(930)	(1031)	(1133)

CUSTOM SIZES AVAILABLE

Window Dimension	CUSTOM SIZES AVAILABLE											
1'-3 1/4"												
	AAN1814	AAN2014	AAN2414	AAN2614	AAN2814	AAN21014	AAN3014	AAN3214	AAN3414	AAN3814	AAN4014	AAN4414
1'-7 1/4"												
	AAN1818	AAN2018	AAN2418	AAN2618	AAN2818	AAN21018	AAN3018	AAN3218	AAN3418	AAN3818	AAN4018	AAN4418
1'-9 1/4"												
	AAN18110	AAN20110	AAN24110	AAN26110	AAN28110	AAN210110	AAN30110	AAN32110	AAN34110	AAN38110	AAN40110	AAN44110
1'-11 1/4"												
	AAN1820	AAN2020	AAN2420	AAN2620	AAN2820	AAN21020	AAN3020	AAN3220	AAN3420	AAN3820	AAN4020	AAN4420
2'-3 1/4"												
	AAN1824	AAN2024	AAN2424	AAN2624	AAN2824	AAN21024	AAN3024	AAN3224	AAN3424	AAN3824	AAN4024	AAN4424
2'-7 1/4"												
	AAN1828	AAN2028	AAN2428	AAN2628	AAN2828	AAN21028	AAN3028	AAN3228	AAN3428	AAN3828	AAN4028	AAN4428
2'-11 1/4"												
	AAN1830*	AAN2030*	AAN2430*	AAN2630*	AAN2830*	AAN21030*	AAN3030*	AAN3230*	AAN3430*	AAN3830*	AAN4030*	AAN4430*
3'-3 1/4"												
	AAN1834**	AAN2034**	AAN2434**	AAN2634**	AAN2834**	AAN21034**	AAN3034**	AAN3234**	AAN3434**	AAN3834**	AAN4034**	AAN4434**
3'-7 1/4"												
	AAN1838**	AAN2038**	AAN2438**	AAN2638**	AAN2838**	AAN21038**	AAN3038**	AAN3238**	AAN3438**	AAN3838**	AAN4038**	AAN4438**
3'-11 1/4"												
	AAN1840**	AAN2040**	AAN2440**	AAN2640**	AAN2840**	AAN21040**	AAN3040**	AAN3240**	AAN3440**	AAN3840**	AAN4040**	AAN4440**



Custom-size windows are available in 1/8" (3) increments. See page 63 for custom sizes and specifications.

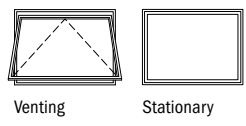

Choose venting or stationary.











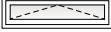
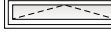
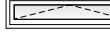
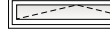
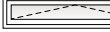

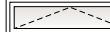

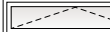









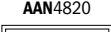
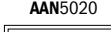
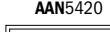







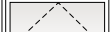
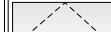
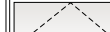
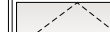
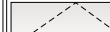
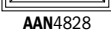



Most sizes shown are available with PG upgrade.†

Awning window must be installed to vent as shown, and should not be rotated and used as a hopper.

Grille patterns and details shown on page 37.

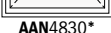
*"Window Dimension" always refers to outside frame-to-frame dimension.
 **"Minimum Rough Opening" dimensions may need to be increased to allow for use of building wraps, flashing, sill panning, brackets, fasteners or other items. See pages 226-227 for more details.
 †Dimensions in parentheses are in millimeters.
 ‡Tandem locks are standard.
 †PG upgrade is not available for venting sizes shown with an underscore on page 33 (i.e. ACW5830).
 ‡Not available with triple-pane annealed glass.
 ††Not available with triple-pane annealed or tempered glass.

4'-7 1/4" (1403)	4'-11 1/4" (1505)	5'-3 1/4" (1607)	5'-7 1/4" (1708)	5'-11 1/4" (1810)
4'-8" (1422)	5'-0" (1524)	5'-4" (1626)	5'-8" (1727)	6'-0" (1829)
48 5/8" (1234)	52 5/8" (1336)	56 5/8" (1438)	60 5/8" (1539)	64 5/8" (1641)

 AAN4814	 AAN5014	 AAN5414	 AAN5814	 AAN6014
 AAN4818	 AAN5018	 AAN5418	 AAN5818	 AAN6018
 AAN48110	 AAN50110	 AAN54110	 AAN58110	 AAN60110
 AAN4820	 AAN5020	 AAN5420	 AAN5820	 AAN6020
 AAN4824	 AAN5024	 AAN5424	 AAN5824	 AAN6024
 AAN4828	 AAN5028	 AAN5428	 AAN5828	 AAN6028
 AAN4830*	 AAN5030*	 AAN5430*	 AAN5830*	 AAN6030*
 AAN4834*†	 AAN5034*†	 AAN5434*†	 AAN5834*†	 AAN6034*†
 AAN4838*††	 AAN5038*††	 AAN5438*††	 AAN5838*††	 AAN6038*††
 AAN4840*††	 AAN5040*††	 AAN5440*††	 AAN5840*††	 AAN6040*††



Custom-size windows are available in 1/8" (3) increments.
See page 63 for custom sizes and specifications.

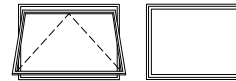

Venting Stationary

Choose venting or stationary.

Most sizes shown are available with PG upgrade†

Awning window must be installed to vent as shown, and should not be rotated and used as a hopper.

Grille patterns and details shown on page 37.

*"Window Dimension" always refers to outside frame-to-frame dimension.
 • **"Minimum Rough Opening" dimensions may need to be increased to allow for use of building wraps, flashing, sill panning, brackets, fasteners or other items. See pages 226-227 for more details.**
 • Dimensions in parentheses are in millimeters.
 ‡PG upgrade is not available for venting sizes shown with an underscore (i.e. **ACW5830**).
 *Tandem locks are standard.
 †Not available with triple-pane annealed glass.
 ††Not available with triple-pane annealed or tempered glass.

AWNING WINDOWS

Awning Window Opening and Area Specifications

Window Number	Clear Opening Area Sq. Ft./ (m ²)	Clear Opening in Full Open Position		Glass Area Sq. Ft./ (m ²)	Vent Area Sq. Ft./ (m ²)	Top of Subfloor to Top of Inside Sill Stop Inches/(mm)	Overall Window Area Sq. Ft./ (m ²)
		Width Inches/(mm)	Depth Inches/(mm)				
AAN1814	0.59 (0.05)	14 5/16" (364)	5 7/8" (150)	0.68 (0.06)	0.59 (0.05)	70 1/16" (1779)	2.04 (0.19)
AAN1818	0.59 (0.05)	14 5/16" (364)	5 7/8" (150)	1.03 (0.10)	0.59 (0.05)	66 1/16" (1678)	2.57 (0.24)
AAN18110	0.59 (0.05)	14 5/16" (364)	5 7/8" (150)	1.21 (0.11)	0.59 (0.05)	64 1/16" (1627)	2.84 (0.26)
AAN1820	0.59 (0.05)	14 5/16" (364)	5 7/8" (150)	1.38 (0.13)	0.59 (0.05)	62 1/16" (1576)	3.11 (0.29)
AAN1824	0.59 (0.05)	14 5/16" (364)	5 7/8" (150)	1.73 (0.16)	0.59 (0.05)	58 1/16" (1475)	3.64 (0.34)
AAN1828	0.59 (0.05)	14 5/16" (364)	5 7/8" (150)	2.08 (0.19)	0.59 (0.05)	54 1/16" (1373)	4.18 (0.39)
AAN1830	0.59 (0.05)	14 5/16" (364)	5 7/8" (150)	2.43 (0.23)	0.59 (0.05)	50 1/16" (1271)	4.71 (0.44)
AAN1834 †	0.59 (0.05)	14 5/16" (364)	5 7/8" (150)	2.78 (0.26)	0.59 (0.05)	46 1/16" (1170)	5.25 (0.49)
AAN1838 †	0.59 (0.05)	14 5/16" (364)	5 7/8" (150)	3.13 (0.29)	0.59 (0.05)	42 1/16" (1068)	5.78 (0.54)
AAN1840 †	0.59 (0.05)	14 5/16" (364)	5 7/8" (150)	3.48 (0.32)	0.59 (0.05)	38 1/16" (967)	6.32 (0.59)
AAN2014	0.75 (0.07)	18 5/16" (465)	5 7/8" (150)	0.90 (0.08)	0.75 (0.07)	70 1/16" (1779)	2.46 (0.23)
AAN2018	0.75 (0.07)	18 5/16" (465)	5 7/8" (150)	1.36 (0.13)	0.75 (0.07)	66 1/16" (1678)	3.11 (0.29)
AAN20110	0.75 (0.07)	18 5/16" (465)	5 7/8" (150)	1.59 (0.15)	0.75 (0.07)	64 1/16" (1627)	3.43 (0.32)
AAN2020	0.75 (0.07)	18 5/16" (465)	5 7/8" (150)	1.82 (0.17)	0.75 (0.07)	62 1/16" (1576)	3.75 (0.35)
AAN2024	0.75 (0.07)	18 5/16" (465)	5 7/8" (150)	2.28 (0.21)	0.75 (0.07)	58 1/16" (1475)	4.40 (0.41)
AAN2028	0.75 (0.07)	18 5/16" (465)	5 7/8" (150)	2.74 (0.25)	0.75 (0.07)	54 1/16" (1373)	5.05 (0.47)
AAN2030	0.75 (0.07)	18 5/16" (465)	5 7/8" (150)	3.21 (0.30)	0.75 (0.07)	50 1/16" (1271)	5.69 (0.53)
AAN2034 †	0.75 (0.07)	18 5/16" (465)	5 7/8" (150)	3.67 (0.34)	0.75 (0.07)	46 1/16" (1170)	6.34 (0.59)
AAN2038 †	0.75 (0.07)	18 5/16" (465)	5 7/8" (150)	4.13 (0.38)	0.75 (0.07)	42 1/16" (1068)	6.98 (0.65)
AAN2040 †	0.75 (0.07)	18 5/16" (465)	5 7/8" (150)	4.59 (0.43)	0.75 (0.07)	38 1/16" (967)	7.63 (0.71)
AAN2414	0.91 (0.08)	22 5/16" (567)	5 7/8" (150)	1.12 (0.10)	0.91 (0.08)	70 1/16" (1779)	2.89 (0.27)
AAN2418	0.91 (0.08)	22 5/16" (567)	5 7/8" (150)	1.69 (0.16)	0.91 (0.08)	66 1/16" (1678)	3.64 (0.34)
AAN24110	0.91 (0.08)	22 5/16" (567)	5 7/8" (150)	1.97 (0.18)	0.91 (0.08)	64 1/16" (1627)	4.02 (0.37)
AAN2420	0.91 (0.08)	22 5/16" (567)	5 7/8" (150)	2.26 (0.21)	0.91 (0.08)	62 1/16" (1576)	4.40 (0.41)
AAN2424	0.91 (0.08)	22 5/16" (567)	5 7/8" (150)	2.83 (0.26)	0.91 (0.08)	58 1/16" (1475)	5.16 (0.48)
AAN2428	0.91 (0.08)	22 5/16" (567)	5 7/8" (150)	3.41 (0.32)	0.91 (0.08)	54 1/16" (1373)	5.91 (0.55)
AAN2430	0.91 (0.08)	22 5/16" (567)	5 7/8" (150)	3.98 (0.37)	0.91 (0.08)	50 1/16" (1271)	6.67 (0.62)
AAN2434 †	0.91 (0.08)	22 5/16" (567)	5 7/8" (150)	4.55 (0.42)	0.91 (0.08)	46 1/16" (1170)	7.43 (0.69)
AAN2438 †	0.91 (0.08)	22 5/16" (567)	5 7/8" (150)	5.12 (0.48)	0.91 (0.08)	42 1/16" (1068)	8.18 (0.76)
AAN2440 †	0.91 (0.08)	22 5/16" (567)	5 7/8" (150)	5.69 (0.53)	0.91 (0.08)	38 1/16" (967)	8.94 (0.83)
AAN2614	0.99 (0.09)	24 5/16" (618)	5 7/8" (150)	1.22 (0.11)	0.99 (0.09)	70 1/16" (1779)	3.10 (0.29)
AAN2618	0.99 (0.09)	24 5/16" (618)	5 7/8" (150)	1.85 (0.17)	0.99 (0.09)	66 1/16" (1678)	3.91 (0.36)
AAN26110	0.99 (0.09)	24 5/16" (618)	5 7/8" (150)	2.17 (0.20)	0.99 (0.09)	64 1/16" (1627)	4.32 (0.40)
AAN2620	0.99 (0.09)	24 5/16" (618)	5 7/8" (150)	2.48 (0.23)	0.99 (0.09)	62 1/16" (1576)	4.72 (0.44)
AAN2624	0.99 (0.09)	24 5/16" (618)	5 7/8" (150)	3.11 (0.29)	0.99 (0.09)	58 1/16" (1475)	5.54 (0.51)
AAN2628	0.99 (0.09)	24 5/16" (618)	5 7/8" (150)	3.75 (0.35)	0.99 (0.09)	54 1/16" (1373)	6.35 (0.59)
AAN2630	0.99 (0.09)	24 5/16" (618)	5 7/8" (150)	4.36 (0.41)	0.99 (0.09)	50 1/16" (1271)	7.16 (0.67)
AAN2634 †	0.99 (0.09)	24 5/16" (618)	5 7/8" (150)	4.99 (0.46)	0.99 (0.09)	46 1/16" (1170)	7.97 (0.74)
AAN2638 †	0.99 (0.09)	24 5/16" (618)	5 7/8" (150)	5.62 (0.52)	0.99 (0.09)	42 1/16" (1068)	8.79 (0.82)
AAN2640 †	0.99 (0.09)	24 5/16" (618)	5 7/8" (150)	6.25 (0.58)	0.99 (0.09)	38 1/16" (967)	9.60 (0.89)
AAN2814	1.08 (0.10)	26 5/16" (668)	5 7/8" (150)	1.33 (0.12)	1.08 (0.10)	70 1/16" (1779)	3.31 (0.31)
AAN2818	1.08 (0.10)	26 5/16" (668)	5 7/8" (150)	2.02 (0.19)	1.08 (0.10)	66 1/16" (1678)	4.18 (0.39)
AAN28110	1.08 (0.10)	26 5/16" (668)	5 7/8" (150)	2.36 (0.22)	1.08 (0.10)	64 1/16" (1627)	4.61 (0.43)
AAN2820	1.08 (0.10)	26 5/16" (668)	5 7/8" (150)	2.70 (0.25)	1.08 (0.10)	62 1/16" (1576)	5.05 (0.47)
AAN2824	1.08 (0.10)	26 5/16" (668)	5 7/8" (150)	3.38 (0.31)	1.08 (0.10)	58 1/16" (1475)	5.91 (0.55)
AAN2828	1.08 (0.10)	26 5/16" (668)	5 7/8" (150)	4.07 (0.38)	1.08 (0.10)	54 1/16" (1373)	6.78 (0.63)
AAN2830	1.08 (0.10)	26 5/16" (668)	5 7/8" (150)	4.75 (0.44)	1.08 (0.10)	50 1/16" (1271)	7.65 (0.71)
AAN2834 †	1.08 (0.10)	26 5/16" (668)	5 7/8" (150)	5.43 (0.50)	1.08 (0.10)	46 1/16" (1170)	8.52 (0.79)
AAN2838 †	1.08 (0.10)	26 5/16" (668)	5 7/8" (150)	6.11 (0.57)	1.08 (0.10)	42 1/16" (1068)	9.39 (0.87)
AAN2840 †	1.08 (0.10)	26 5/16" (668)	5 7/8" (150)	6.80 (0.63)	1.08 (0.10)	38 1/16" (967)	10.25 (0.95)
AAN21014	1.16 (0.11)	28 5/16" (719)	5 7/8" (150)	1.44 (0.13)	1.16 (0.11)	70 1/16" (1779)	3.52 (0.33)
AAN21018	1.16 (0.11)	28 5/16" (719)	5 7/8" (150)	2.18 (0.20)	1.16 (0.11)	66 1/16" (1678)	4.45 (0.41)
AAN210110	1.16 (0.11)	28 5/16" (719)	5 7/8" (150)	2.55 (0.24)	1.16 (0.11)	64 1/16" (1627)	4.91 (0.46)
AAN21020	1.16 (0.11)	28 5/16" (719)	5 7/8" (150)	2.92 (0.27)	1.16 (0.11)	62 1/16" (1576)	5.37 (0.50)
AAN21024	1.16 (0.11)	28 5/16" (719)	5 7/8" (150)	3.66 (0.34)	1.16 (0.11)	58 1/16" (1475)	6.29 (0.58)
AAN21028	1.16 (0.11)	28 5/16" (719)	5 7/8" (150)	4.40 (0.41)	1.16 (0.11)	54 1/16" (1373)	7.22 (0.67)
AAN21030	1.16 (0.11)	28 5/16" (719)	5 7/8" (150)	5.14 (0.48)	1.16 (0.11)	50 1/16" (1271)	8.14 (0.76)
AAN21034 †	1.16 (0.11)	28 5/16" (719)	5 7/8" (150)	5.87 (0.55)	1.16 (0.11)	46 1/16" (1170)	9.06 (0.84)
AAN21038 †	1.16 (0.11)	28 5/16" (719)	5 7/8" (150)	6.61 (0.61)	1.16 (0.11)	42 1/16" (1068)	9.99 (0.93)

* "Top of Subfloor to Top of Inside Sill Stop" is calculated based upon a structural header height of 6'-10 1/2" (2096).

continued on next page

† Dimensions in parentheses are in millimeters or square meters.

† Not available with triple-pane annealed glass.

Awning Window Opening and Area Specifications *(continued)*

Window Number	Clear Opening Area Sq. Ft./ (m ²)	Clear Opening in Full Open Position		Glass Area Sq. Ft./ (m ²)	Vent Area Sq. Ft./ (m ²)	Top of Subfloor to Top of Inside Sill Stop Inches/ (mm)	Overall Window Area Sq. Ft./ (m ²)
		Width Inches/ (mm)	Depth Inches/ (mm)				
AAN21040 †	1.16 (0.11)	28 5/16" (719)	5 7/8" (150)	7.35 (0.68)	1.16 (0.11)	38 1/16" (967)	10.91 (1.01)
AAN3014	1.24 (0.12)	30 5/16" (770)	5 7/8" (150)	1.55 (0.14)	1.24 (0.12)	70 1/16" (1779)	3.73 (0.35)
AAN3018	1.24 (0.12)	30 5/16" (770)	5 7/8" (150)	2.34 (0.22)	1.24 (0.12)	66 1/16" (1678)	4.71 (0.44)
AAN30110	1.24 (0.12)	30 5/16" (770)	5 7/8" (150)	2.74 (0.25)	1.24 (0.12)	64 1/16" (1627)	5.20 (0.48)
AAN3020	1.24 (0.12)	30 5/16" (770)	5 7/8" (150)	3.14 (0.29)	1.24 (0.12)	62 1/16" (1576)	5.69 (0.53)
AAN3024	1.24 (0.12)	30 5/16" (770)	5 7/8" (150)	3.93 (0.37)	1.24 (0.12)	58 1/16" (1475)	6.67 (0.62)
AAN3028	1.24 (0.12)	30 5/16" (770)	5 7/8" (150)	4.73 (0.44)	1.24 (0.12)	54 1/16" (1373)	7.56 (0.70)
AAN3030	1.24 (0.12)	30 5/16" (770)	5 7/8" (150)	5.52 (0.51)	1.24 (0.12)	50 1/16" (1271)	8.63 (0.80)
AAN3034 †	1.24 (0.12)	30 5/16" (770)	5 7/8" (150)	6.32 (0.59)	1.24 (0.12)	46 1/16" (1170)	9.61 (0.89)
AAN3038 †	1.24 (0.12)	30 5/16" (770)	5 7/8" (150)	7.11 (0.66)	1.24 (0.12)	42 1/16" (1068)	10.59 (0.98)
AAN3040 †	1.24 (0.12)	30 5/16" (770)	5 7/8" (150)	7.90 (0.73)	1.24 (0.12)	38 1/16" (967)	11.57 (1.07)
AAN3214	1.32 (0.12)	32 5/16" (821)	5 7/8" (150)	1.66 (0.15)	1.32 (0.12)	70 1/16" (1779)	3.95 (0.37)
AAN3218	1.32 (0.12)	32 5/16" (821)	5 7/8" (150)	2.51 (0.23)	1.32 (0.12)	66 1/16" (1678)	4.98 (0.46)
AAN32110	1.32 (0.12)	32 5/16" (821)	5 7/8" (150)	2.93 (0.27)	1.32 (0.12)	64 1/16" (1627)	5.50 (0.51)
AAN3220	1.32 (0.12)	32 5/16" (821)	5 7/8" (150)	3.36 (0.31)	1.32 (0.12)	62 1/16" (1576)	6.01 (0.56)
AAN3224	1.32 (0.12)	32 5/16" (821)	5 7/8" (150)	4.21 (0.39)	1.32 (0.12)	58 1/16" (1475)	7.05 (0.65)
AAN3228	1.32 (0.12)	32 5/16" (821)	5 7/8" (150)	5.06 (0.47)	1.32 (0.12)	54 1/16" (1373)	8.08 (0.75)
AAN3230	1.32 (0.12)	32 5/16" (821)	5 7/8" (150)	5.91 (0.55)	1.32 (0.12)	50 1/16" (1271)	9.12 (0.85)
AAN3234 †	1.32 (0.12)	32 5/16" (821)	5 7/8" (150)	6.76 (0.63)	1.32 (0.12)	46 1/16" (1170)	10.15 (0.94)
AAN3238 †	1.32 (0.12)	32 5/16" (821)	5 7/8" (150)	7.61 (0.71)	1.32 (0.12)	42 1/16" (1068)	11.19 (1.04)
AAN3240 †	1.32 (0.12)	32 5/16" (821)	5 7/8" (150)	8.46 (0.79)	1.32 (0.12)	38 1/16" (967)	12.22 (1.14)
AAN3414	1.40 (0.13)	34 5/16" (872)	5 7/8" (150)	1.77 (0.16)	1.40 (0.13)	70 1/16" (1779)	4.16 (0.39)
AAN3418	1.40 (0.13)	34 5/16" (872)	5 7/8" (150)	2.67 (0.25)	1.40 (0.13)	66 1/16" (1678)	5.25 (0.49)
AAN34110	1.40 (0.13)	34 5/16" (872)	5 7/8" (150)	3.12 (0.29)	1.40 (0.13)	64 1/16" (1627)	5.79 (0.54)
AAN3420	1.40 (0.13)	34 5/16" (872)	5 7/8" (150)	3.58 (0.33)	1.40 (0.13)	62 1/16" (1576)	6.34 (0.59)
AAN3424	1.40 (0.13)	34 5/16" (872)	5 7/8" (150)	4.48 (0.42)	1.40 (0.13)	58 1/16" (1475)	7.43 (0.69)
AAN3428	1.40 (0.13)	34 5/16" (872)	5 7/8" (150)	5.39 (0.50)	1.40 (0.13)	54 1/16" (1373)	8.52 (0.79)
AAN3430	1.40 (0.13)	34 5/16" (872)	5 7/8" (150)	6.29 (0.58)	1.40 (0.13)	50 1/16" (1271)	9.61 (0.89)
AAN3434 †	1.40 (0.13)	34 5/16" (872)	5 7/8" (150)	7.20 (0.67)	1.40 (0.13)	46 1/16" (1170)	10.70 (0.99)
AAN3438 †	1.40 (0.13)	34 5/16" (872)	5 7/8" (150)	8.10 (0.75)	1.40 (0.13)	42 1/16" (1068)	11.79 (1.10)
AAN3440 †	1.40 (0.13)	34 5/16" (872)	5 7/8" (150)	9.01 (0.84)	1.40 (0.13)	38 1/16" (967)	12.88 (1.20)
AAN3814	1.57 (0.15)	38 5/16" (973)	5 7/8" (150)	1.98 (0.18)	1.57 (0.15)	70 1/16" (1779)	4.58 (0.43)
AAN3818	1.57 (0.15)	38 5/16" (973)	5 7/8" (150)	3.00 (0.28)	1.57 (0.15)	66 1/16" (1678)	5.78 (0.54)
AAN38110	1.57 (0.15)	38 5/16" (973)	5 7/8" (150)	3.51 (0.33)	1.57 (0.15)	64 1/16" (1627)	6.38 (0.59)
AAN3820	1.57 (0.15)	38 5/16" (973)	5 7/8" (150)	4.02 (0.37)	1.57 (0.15)	62 1/16" (1576)	6.98 (0.65)
AAN3824	1.57 (0.15)	38 5/16" (973)	5 7/8" (150)	5.03 (0.47)	1.57 (0.15)	58 1/16" (1475)	8.18 (0.76)
AAN3828	1.57 (0.15)	38 5/16" (973)	5 7/8" (150)	6.05 (0.56)	1.57 (0.15)	54 1/16" (1373)	9.39 (0.87)
AAN3830	1.57 (0.15)	38 5/16" (973)	5 7/8" (150)	7.07 (0.66)	1.57 (0.15)	50 1/16" (1271)	10.59 (0.98)
AAN3834 †	1.57 (0.15)	38 5/16" (973)	5 7/8" (150)	8.08 (0.75)	1.57 (0.15)	46 1/16" (1170)	11.79 (1.10)
AAN3838 ††	1.57 (0.15)	38 5/16" (973)	5 7/8" (150)	9.10 (0.85)	1.57 (0.15)	42 1/16" (1068)	12.99 (1.21)
AAN3840 ††	1.57 (0.15)	38 5/16" (973)	5 7/8" (150)	10.12 (0.94)	1.57 (0.15)	38 1/16" (967)	14.19 (1.32)
AAN4014	1.73 (0.16)	42 5/16" (1075)	5 7/8" (150)	2.20 (0.20)	1.73 (0.16)	70 1/16" (1779)	5.00 (0.46)
AAN4018	1.73 (0.16)	42 5/16" (1075)	5 7/8" (150)	3.33 (0.31)	1.73 (0.16)	66 1/16" (1678)	6.32 (0.59)
AAN40110	1.73 (0.16)	42 5/16" (1075)	5 7/8" (150)	3.89 (0.36)	1.73 (0.16)	64 1/16" (1627)	6.97 (0.65)
AAN4020	1.73 (0.16)	42 5/16" (1075)	5 7/8" (150)	4.46 (0.41)	1.73 (0.16)	62 1/16" (1576)	7.63 (0.71)
AAN4024	1.73 (0.16)	42 5/16" (1075)	5 7/8" (150)	5.58 (0.52)	1.73 (0.16)	58 1/16" (1475)	8.94 (0.83)
AAN4028	1.73 (0.16)	42 5/16" (1075)	5 7/8" (150)	6.71 (0.62)	1.73 (0.16)	54 1/16" (1373)	10.25 (0.95)
AAN4030	1.73 (0.16)	42 5/16" (1075)	5 7/8" (150)	7.84 (0.73)	1.73 (0.16)	50 1/16" (1271)	11.57 (1.07)
AAN4034 †	1.73 (0.16)	42 5/16" (1075)	5 7/8" (150)	8.97 (0.83)	1.73 (0.16)	46 1/16" (1170)	12.88 (1.20)
AAN4038 ††	1.73 (0.16)	42 5/16" (1075)	5 7/8" (150)	10.09 (0.94)	1.73 (0.16)	42 1/16" (1068)	14.19 (1.32)
AAN4040 ††	1.73 (0.16)	42 5/16" (1075)	5 7/8" (150)	11.22 (1.04)	1.73 (0.16)	38 1/16" (967)	15.50 (1.44)
AAN4414	1.90 (0.18)	46 5/16" (1176)	5 7/8" (150)	2.42 (0.22)	1.90 (0.18)	70 1/16" (1779)	5.43 (0.50)
AAN4418	1.90 (0.18)	46 5/16" (1176)	5 7/8" (150)	3.66 (0.34)	1.90 (0.18)	66 1/16" (1678)	6.85 (0.64)
AAN44110	1.90 (0.18)	46 5/16" (1176)	5 7/8" (150)	4.27 (0.40)	1.90 (0.18)	64 1/16" (1627)	7.56 (0.70)
AAN4420	1.90 (0.18)	46 5/16" (1176)	5 7/8" (150)	4.89 (0.45)	1.90 (0.18)	62 1/16" (1576)	8.28 (0.77)
AAN4424	1.90 (0.18)	46 5/16" (1176)	5 7/8" (150)	6.13 (0.57)	1.90 (0.18)	58 1/16" (1475)	9.70 (0.90)
AAN4428	1.90 (0.18)	46 5/16" (1176)	5 7/8" (150)	7.37 (0.68)	1.90 (0.18)	54 1/16" (1373)	11.12 (1.03)
AAN4430	1.90 (0.18)	46 5/16" (1176)	5 7/8" (150)	8.61 (0.80)	1.90 (0.18)	50 1/16" (1271)	12.55 (1.17)
AAN4434 †	1.90 (0.18)	46 5/16" (1176)	5 7/8" (150)	9.85 (0.92)	1.90 (0.18)	46 1/16" (1170)	13.97 (1.30)

* "Top of Subfloor to Top of Inside Sill Stop" is calculated based upon a structural header height of 6'-10 1/2" (2096).

continued on next page

† Dimensions in parentheses are in millimeters or square meters.
†† Not available with triple-pane annealed glass.
††† Not available with triple-pane annealed or tempered glass.

A-Series Casement & Awning Windows

AWNING WINDOWS

Awning Window Opening and Area Specifications (continued)

Window Number	Clear Opening Area Sq. Ft./ (m ²)	Clear Opening in Full Open Position		Glass Area Sq. Ft./ (m ²)	Vent Area Sq. Ft./ (m ²)	Top of Subfloor to Top of Inside Sill Stop Inches/(mm)	Overall Window Area Sq. Ft./ (m ²)
		Width Inches/(mm)	Depth Inches/(mm)				
AAN4438 ††	1.90 (0.18)	46 5/16" (1176)	5 7/8" (150)	11.09 (1.03)	1.90 (0.18)	42 1/16" (1068)	15.39 (1.43)
AAN4440 ††	1.90 (0.18)	46 5/16" (1176)	5 7/8" (150)	12.33 (1.15)	1.90 (0.18)	38 1/16" (967)	16.82 (1.56)
AAN4814	2.06 (0.19)	50 5/16" (1278)	5 7/8" (150)	2.63 (0.24)	2.06 (0.19)	70 1/16" (1779)	5.85 (0.54)
AAN4818	2.06 (0.19)	50 5/16" (1278)	5 7/8" (150)	3.98 (0.37)	2.06 (0.19)	66 1/16" (1678)	7.39 (0.69)
AAN48110	2.06 (0.19)	50 5/16" (1278)	5 7/8" (150)	4.66 (0.43)	2.06 (0.19)	64 1/16" (1627)	8.15 (0.76)
AAN4820	2.06 (0.19)	50 5/16" (1278)	5 7/8" (150)	5.33 (0.50)	2.06 (0.19)	62 1/16" (1576)	8.92 (0.83)
AAN4824	2.06 (0.19)	50 5/16" (1278)	5 7/8" (150)	6.68 (0.62)	2.06 (0.19)	58 1/16" (1475)	10.46 (0.97)
AAN4828	2.06 (0.19)	50 5/16" (1278)	5 7/8" (150)	8.03 (0.75)	2.06 (0.19)	54 1/16" (1373)	11.99 (1.11)
AAN4830	2.06 (0.19)	50 5/16" (1278)	5 7/8" (150)	9.38 (0.87)	2.06 (0.19)	50 1/16" (1271)	13.53 (1.26)
AAN4834 †	2.06 (0.19)	50 5/16" (1278)	5 7/8" (150)	10.73 (1.00)	2.06 (0.19)	46 1/16" (1170)	15.06 (1.40)
AAN4838 ††	2.06 (0.19)	50 5/16" (1278)	5 7/8" (150)	12.08 (1.12)	2.06 (0.19)	42 1/16" (1068)	16.59 (1.54)
AAN4840 ††	2.06 (0.19)	50 5/16" (1278)	5 7/8" (150)	13.43 (1.25)	2.06 (0.19)	38 1/16" (967)	18.13 (1.68)
AAN5014	2.22 (0.21)	54 5/16" (1380)	5 7/8" (150)	2.85 (0.26)	2.22 (0.21)	70 1/16" (1779)	6.28 (0.58)
AAN5018	2.22 (0.21)	54 5/16" (1380)	5 7/8" (150)	4.31 (0.40)	2.22 (0.21)	66 1/16" (1678)	7.92 (0.74)
AAN50110	2.22 (0.21)	54 5/16" (1380)	5 7/8" (150)	5.04 (0.47)	2.22 (0.21)	64 1/16" (1627)	8.74 (0.81)
AAN5020	2.22 (0.21)	54 5/16" (1380)	5 7/8" (150)	5.77 (0.54)	2.22 (0.21)	62 1/16" (1576)	9.57 (0.89)
AAN5024	2.22 (0.21)	54 5/16" (1380)	5 7/8" (150)	7.23 (0.67)	2.22 (0.21)	58 1/16" (1475)	11.21 (1.04)
AAN5028	2.22 (0.21)	54 5/16" (1380)	5 7/8" (150)	9.36 (0.87)	2.22 (0.21)	54 1/16" (1373)	13.73 (1.28)
AAN5030	2.22 (0.21)	54 5/16" (1380)	5 7/8" (150)	10.16 (0.94)	2.22 (0.21)	50 1/16" (1271)	14.50 (1.35)
AAN5034 †	2.22 (0.21)	54 5/16" (1380)	5 7/8" (150)	11.62 (1.08)	2.22 (0.21)	46 1/16" (1170)	16.15 (1.50)
AAN5038 ††	2.22 (0.21)	54 5/16" (1380)	5 7/8" (150)	13.08 (1.22)	2.22 (0.21)	42 1/16" (1068)	17.80 (1.65)
AAN5040 ††	2.22 (0.21)	54 5/16" (1380)	5 7/8" (150)	14.54 (1.35)	2.22 (0.21)	38 1/16" (967)	19.44 (1.81)
AAN5414	2.39 (0.22)	58 5/16" (1481)	5 7/8" (150)	3.07 (0.29)	2.39 (0.22)	70 1/16" (1779)	6.70 (0.62)
AAN5418	2.39 (0.22)	58 5/16" (1481)	5 7/8" (150)	4.64 (0.43)	2.39 (0.22)	66 1/16" (1678)	8.46 (0.79)
AAN54110	2.39 (0.22)	58 5/16" (1481)	5 7/8" (150)	5.42 (0.50)	2.39 (0.22)	64 1/16" (1627)	9.33 (0.87)
AAN5420	2.39 (0.22)	58 5/16" (1481)	5 7/8" (150)	6.21 (0.58)	2.39 (0.22)	62 1/16" (1576)	10.21 (0.95)
AAN5424	2.39 (0.22)	58 5/16" (1481)	5 7/8" (150)	7.78 (0.72)	2.39 (0.22)	58 1/16" (1475)	11.97 (1.11)
AAN5428	2.39 (0.22)	58 5/16" (1481)	5 7/8" (150)	8.69 (0.81)	2.39 (0.22)	54 1/16" (1373)	12.86 (1.19)
AAN5430	2.39 (0.22)	58 5/16" (1481)	5 7/8" (150)	10.93 (1.02)	2.39 (0.22)	50 1/16" (1271)	15.48 (1.44)
AAN5434 †	2.39 (0.22)	58 5/16" (1481)	5 7/8" (150)	12.50 (1.16)	2.39 (0.22)	46 1/16" (1170)	17.24 (1.60)
AAN5438 ††	2.39 (0.22)	58 5/16" (1481)	5 7/8" (150)	14.07 (1.31)	2.39 (0.22)	42 1/16" (1068)	19.00 (1.77)
AAN5440 ††	2.39 (0.22)	58 5/16" (1481)	5 7/8" (150)	15.64 (1.45)	2.39 (0.22)	38 1/16" (967)	20.75 (1.93)
AAN5814	2.55 (0.24)	62 5/16" (1583)	5 7/8" (150)	3.28 (0.30)	2.55 (0.24)	70 1/16" (1779)	7.12 (0.66)
AAN5818	2.55 (0.24)	62 5/16" (1583)	5 7/8" (150)	4.97 (0.46)	2.55 (0.24)	66 1/16" (1678)	8.99 (0.84)
AAN58110	2.55 (0.24)	62 5/16" (1583)	5 7/8" (150)	5.81 (0.54)	2.55 (0.24)	64 1/16" (1627)	9.92 (0.92)
AAN5820	2.55 (0.24)	62 5/16" (1583)	5 7/8" (150)	6.65 (0.62)	2.55 (0.24)	62 1/16" (1576)	10.86 (1.01)
AAN5824	2.55 (0.24)	62 5/16" (1583)	5 7/8" (150)	8.33 (0.77)	2.55 (0.24)	58 1/16" (1475)	12.73 (1.18)
AAN5828	2.55 (0.24)	62 5/16" (1583)	5 7/8" (150)	10.02 (0.93)	2.55 (0.24)	54 1/16" (1373)	14.59 (1.36)
AAN5830	2.55 (0.24)	62 5/16" (1583)	5 7/8" (150)	11.70 (1.09)	2.55 (0.24)	50 1/16" (1271)	16.46 (1.53)
AAN5834 †	2.55 (0.24)	62 5/16" (1583)	5 7/8" (150)	13.38 (1.24)	2.55 (0.24)	46 1/16" (1170)	18.33 (1.70)
AAN5838 ††	2.55 (0.24)	62 5/16" (1583)	5 7/8" (150)	15.07 (1.40)	2.55 (0.24)	42 1/16" (1068)	20.20 (1.88)
AAN5840 ††	2.55 (0.24)	62 5/16" (1583)	5 7/8" (150)	16.75 (1.56)	2.55 (0.24)	38 1/16" (967)	22.07 (2.05)
AAN6014	2.71 (0.25)	66 5/16" (1684)	5 7/8" (150)	3.50 (0.33)	2.71 (0.25)	70 1/16" (1779)	7.55 (0.70)
AAN6018	2.71 (0.25)	66 5/16" (1684)	5 7/8" (150)	5.29 (0.49)	2.71 (0.25)	66 1/16" (1678)	9.53 (0.89)
AAN60110	2.71 (0.25)	66 5/16" (1684)	5 7/8" (150)	6.19 (0.58)	2.71 (0.25)	64 1/16" (1627)	10.51 (0.98)
AAN6020	2.71 (0.25)	66 5/16" (1684)	5 7/8" (150)	7.09 (0.66)	2.71 (0.25)	62 1/16" (1576)	11.50 (1.07)
AAN6024	2.71 (0.25)	66 5/16" (1684)	5 7/8" (150)	8.88 (0.82)	2.71 (0.25)	58 1/16" (1475)	13.48 (1.25)
AAN6028	2.71 (0.25)	66 5/16" (1684)	5 7/8" (150)	10.68 (0.99)	2.71 (0.25)	54 1/16" (1373)	15.46 (1.44)
AAN6030	2.71 (0.25)	66 5/16" (1684)	5 7/8" (150)	12.47 (1.16)	2.71 (0.25)	50 1/16" (1271)	17.44 (1.62)
AAN6034 †	2.71 (0.25)	66 5/16" (1684)	5 7/8" (150)	14.27 (1.33)	2.71 (0.25)	46 1/16" (1170)	19.42 (1.80)
AAN6038 ††	2.71 (0.25)	66 5/16" (1684)	5 7/8" (150)	16.06 (1.49)	2.71 (0.25)	42 1/16" (1068)	21.40 (1.99)
AAN6040 ††	2.71 (0.25)	66 5/16" (1684)	5 7/8" (150)	17.85 (1.66)	2.71 (0.25)	38 1/16" (967)	23.38 (2.17)

*Top of Subfloor to Top of Inside Sill Stop" is calculated based upon a structural header height of 6'-10 1/2" (2096).

• Dimensions in parentheses are in millimeters or square meters.

†Not available with triple-pane annealed glass.

††Not available with triple-pane annealed or tempered glass.

Grille Patterns

	Queen Anne	Diamond	Prairie A	Specified Equal Light with Simulated Check Rail	Colonial	Modified Colonial	Modified Colonial with Simulated Check Rail	Tall Fractional	Tall Fractional with Simulated Check Rail	Short Fractional	Short Fractional with Simulated Check Rail
Casement											
Awning											

Number of lights and overall pattern varies with window size.

Patterns may not be available in all configurations or sizes.

Six-light prairie, specified equal light, specified equal light fractional and custom patterns are also available. For more grille options, see page 19 or visit andersenwindows.com/grilles.

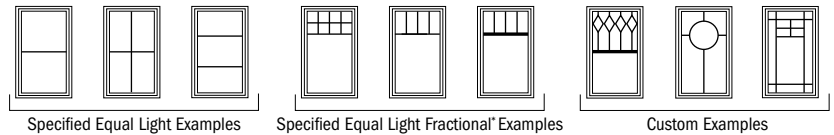

*Bottom horizontal bar located at center or at custom dimensions.

A-Series Casement & Awning Windows

Awning Window Details

Scale 1 1/2" (38) = 1'-0" (305) – 1:8

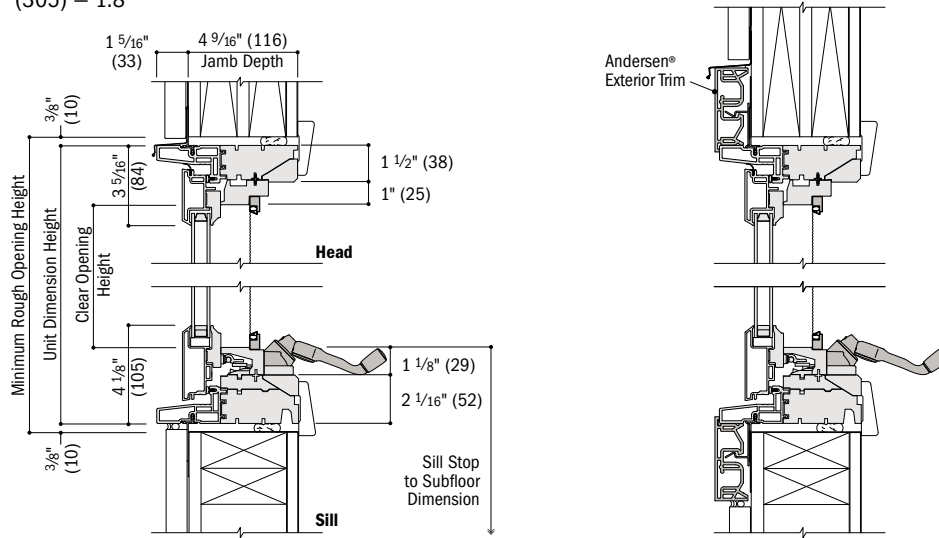

Vertical Section

Vertical Section

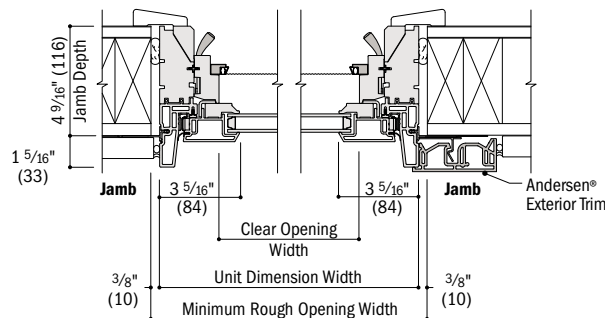

Horizontal Section

See pages 60-62 for joining details.

- 4 9/16" (116) base jamb depth measurement is from backside of installation flange.
- Light-colored areas are parts included with window. Dark-colored areas are additional Andersen® parts required to complete window assembly as shown.
- Dimensions in parentheses are in millimeters.
- Minimum rough openings may need to be increased to allow for use of building wraps, flashing, sill panning, brackets, fasteners or other items. See installation information on pages 226-227.
- Details are for illustration only and are not intended to represent product installation methods or materials. Refer to product installation instructions at andersenwindows.com.

DOUBLE-HUNG WINDOWS

Table of Double-Hung Window Sizes

Scale 1/8" (3) = 1'-0" (305) – 1:96

Notes on the next page also apply to this page.

Unit Dimension	1'-7 1/4"	1'-11 1/4"	2'-3 1/4"	2'-5 1/4"	2'-7 1/4"	2'-9 1/4"	2'-11 1/4"	3'-1 1/4"	3'-3 1/4"	3'-7 1/4"	3'-11 1/4"
	(489)	(591)	(692)	(743)	(794)	(845)	(895)	(946)	(997)	(1099)	(1200)
Minimum Rough Opening	1'-8"	2'-0"	2'-4"	2'-6"	2'-8"	2'-10"	3'-0"	3'-2"	3'-4"	3'-8"	4'-0"
	(508)	(610)	(711)	(762)	(813)	(864)	(914)	(965)	(1016)	(1118)	(1219)
Unobstructed Glass (lower sash only)	12 5/8"	16 5/8"	20 5/8"	22 5/8"	24 5/8"	26 5/8"	28 5/8"	30 5/8"	32 5/8"	36 5/8"	40 5/8"
	(321)	(422)	(524)	(575)	(625)	(676)	(727)	(778)	(829)	(930)	(1032)

2:3 cottage or 3:2 reverse cottage sash ratio available for all standard widths and heights up to 6'-7 1/4" (2013).
CUSTOM WIDTHS – 15 1/4" to 47 1/4"
CUSTOM HEIGHTS – 31 1/4" to 80 1/4"

CUSTOM WIDTHS – 15 1/4" to 47 1/4"											
CUSTOM HEIGHTS – 27 1/4" to 95 1/4"											
2'-11 1/4"	3'-3 1/4"	3'-7 1/4"	3'-11 1/4"	4'-3 1/4"	4'-7 1/4"	4'-11 1/4"	5'-3 1/4"	5'-7 1/4"	5'-11 1/4"	6'-3 1/4"	
(895)	(997)	(1099)	(1200)	(1302)	(1403)	(1505)	(1607)	(1708)	(1810)	(1911)	
3'-0"	3'-4"	3'-8"	4'-0"	4'-4"	4'-8"	5'-0"	5'-4"	5'-8"	6'-0"	6'-4"	
(914)	(1016)	(1118)	(1219)	(1321)	(1422)	(1524)	(1626)	(1727)	(1829)	(1930)	
12 13/16"	14 13/16"	16 13/16"	18 13/16"	20 13/16"	22 13/16"	24 13/16"	26 13/16"	28 13/16"	30 13/16"	32 13/16"	
(325)	(376)	(427)	(478)	(529)	(579)	(630)	(681)	(732)	(783)	(833)	
ADH1830	ADH2030	ADH2430	ADH2630	ADH2830	ADH21030	ADH3030	ADH3230	ADH3430	ADH3830*	ADH4030*	
ADH1834	ADH2034	ADH2434	ADH2634	ADH2834	ADH21034	ADH3034	ADH3234	ADH3434	ADH3834*	ADH4034*	
ADH1838	ADH2038	ADH2438	ADH2638	ADH2838	ADH21038	ADH3038	ADH3238	ADH3438	ADH3838*	ADH4038*	
ADH1840	ADH2040	ADH2440	ADH2640	ADH2840	ADH21040	ADH3040	ADH3240	ADH3440	ADH3840*	ADH4040*	
ADH1844	ADH2044	ADH2444	ADH2644	ADH2844	ADH21044	ADH3044	ADH3244	ADH3444	ADH3844*	ADH4044*	
ADH1848	ADH2048	ADH2448	ADH2648	ADH2848	ADH21048	ADH3048	ADH3248	ADH3448	ADH3848*	ADH4048*	
ADH1850	ADH2050	ADH2450	ADH2650	ADH2850	ADH21050	ADH3050	ADH3250 ⁰	ADH3450 ⁰	ADH3850 ^{0*}	ADH4050 ^{0*}	
ADH1854	ADH2054	ADH2454	ADH2654	ADH2854	ADH21054	ADH3054 ⁰	ADH3254 ⁰	ADH3454 ⁰	ADH3854 ^{0*}	ADH4054 ^{0*}	
ADH1858	ADH2058	ADH2458	ADH2658	ADH2858	ADH21058 ⁰	ADH3058 ⁰	ADH3258 ⁰	ADH3458 ⁰	ADH3858 ^{0*}	ADH4058 ^{0*}	
ADH1860	ADH2060	ADH2460	ADH2660	ADH2860 ⁰	ADH21060 ⁰	ADH3060 ⁰	ADH3260 ⁰	ADH3460 ⁰	ADH3860 ^{0*}	ADH4060 ^{0*}	
ADH1864	ADH2064	ADH2464	ADH2664 ⁰	ADH2864 ⁰	ADH21064 ⁰	ADH3064 ⁰	ADH3264 ⁰	ADH3464 ⁰	ADH3864 ^{0*}	ADH4064 ^{0**}	

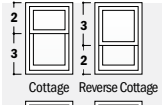

continued on next page

Table of Double-Hung Window Sizes (continued)

Scale 1/8" (3) = 1'-0" (305) – 1:96

Unit Dimension	1'-7 1/4" (489)	1'-11 1/4" (591)	2'-3 1/4" (692)	2'-5 1/4" (743)	2'-7 1/4" (794)	2'-9 1/4" (845)	2'-11 1/4" (895)	3'-1 1/4" (946)	3'-3 1/4" (997)	3'-7 1/4" (1099)	3'-11 1/4" (1200)
Minimum Rough Opening	1'-8" (508)	2'-0" (610)	2'-4" (711)	2'-6" (762)	2'-8" (813)	2'-10" (864)	3'-0" (914)	3'-2" (965)	3'-4" (1016)	3'-8" (1118)	4'-0" (1219)
Unobstructed Glass (lower sash only)	12 5/8" (321)	16 5/8" (422)	20 5/8" (524)	22 5/8" (575)	24 5/8" (625)	26 5/8" (676)	28 5/8" (727)	30 5/8" (778)	32 5/8" (829)	36 5/8" (930)	40 5/8" (1031)

2:3 cottage or 3:2 reverse cottage sash ratio available for all standard widths and heights up to 6'-7 1/4" (2013).
CUSTOM WIDTHS – 15 1/4" to 47 1/4"
CUSTOM HEIGHTS – 31 3/4" to 80 7/8"

CUSTOM WIDTHS – 15 1/4" to 47 1/4"

CUSTOM HEIGHTS – 27 1/4" to 95 1/4"

6'-7 1/4" (2013) 6'-8" (2032) 34 13/16" (884)

7'-3 1/4" (2216) 7'-4" (2235) 38 13/16" (986)

7'-11 1/4" (2419) 8'-0" (2438) 42 13/16" (1087)

ADH1868 ADH2068 ADH2468 ADH2668⁰ ADH2868⁰ ADH21068⁰ ADH3068⁰ ADH3268⁰ ADH3468⁰ ADH3868^{0**} ADH4068^{0**}

ADH1874 ADH2074 ADH2474⁰ ADH2674⁰ ADH2874⁰ ADH21074⁰ ADH3074⁰ ADH3274⁰ ADH3474^{0*} ADH3874^{0**} ADH4074^{0**}

ADH1880 ADH2080 ADH2480⁰ ADH2680⁰ ADH2880⁰ ADH21080⁰ ADH3080^{0*} ADH3280^{0*} ADH3480^{0*} ADH3880^{0**} ADH4080^{0**}

Cottage Reverse Cottage

A-Series Double-Hung Windows



Custom-size windows are available in 1/8" (3) increments. See page 64 for custom sizes and specifications, including windows with cottage and reverse cottage sash.

All sizes shown are available with PG upgrade.† All cottage and reverse cottage sash double-hung window sizes are also available with PG upgrade.‡

For windows with dual-pane glass, two locks are standard on windows wider than 3'-3 1/4" (997). For windows with triple-pane glass or art glass, two locks are standard on sizes wider than 1'-7 1/8" (486) (all sizes shown). Two locks are standard for all windows with PG upgrade.

Grille patterns and details are shown on page 43.

* "Window Dimension" always refers to outside frame-to-frame dimension.
 † "Minimum Rough Opening" dimensions may need to be increased to allow for use of building wraps, flashing, sill panning, brackets, fasteners or other items. See pages 226-227 for more details.
 • Dimensions in parentheses are in millimeters.
 • Two locks are standard for windows with triple-pane glass or art glass on sizes wider than 1'-7 1/8" (486) (all sizes shown). Two locks are standard for all windows with PG upgrade.
 ‡ PG upgrade is not available for custom sizes less than 19 1/4" (489) wide.
 ◊ Meets or exceeds clear opening area of 5.7 sq. ft. or 0.53 m², clear opening width of 20" (508) and clear opening height of 24" (610). See tables on pages 40-42.
 ♦ Limited sash travel for windows with triple-pane glass or art glass. Sizes 3880 and 4080 are not available with art glass.
 * Two locks are standard for windows with dual-pane glass on sizes wider than 3'-3 1/4" (997).

DOUBLE-HUNG WINDOWS

Double-Hung Window Opening and Area Specifications

Window Number	Clear Opening Area Sq. Ft./ (m ²)	Clear Opening in Full Open Position		Glass Area Sq. Ft./ (m ²)	Vent Area Sq. Ft./ (m ²)	Top of Subfloor to Top of Inside Sill Stop Inches/ (mm)	Overall Window Area Sq. Ft./ (m ²)
		Width Inches/ (mm)	Height Inches/ (mm)				
ADH1830	1.37 (0.13)	15 3/16" (386)	13" (330)	2.24 (0.21)	1.46 (0.14)	48 7/8" (1242)	4.71 (0.44)
ADH1834	1.58 (0.15)	15 3/16" (386)	15" (380)	2.59 (0.24)	1.67 (0.16)	44 7/8" (1140)	5.25 (0.49)
ADH1838	1.79 (0.17)	15 3/16" (386)	17" (431)	2.94 (0.27)	1.88 (0.17)	40 7/8" (1039)	5.78 (0.54)
ADH1840	2.00 (0.19)	15 3/16" (386)	19" (482)	3.29 (0.31)	2.09 (0.19)	36 7/8" (937)	6.32 (0.59)
ADH1844	2.21 (0.21)	15 3/16" (386)	21" (533)	3.64 (0.34)	2.30 (0.21)	32 7/8" (836)	6.85 (0.64)
ADH1848	2.42 (0.23)	15 3/16" (386)	23" (584)	3.99 (0.37)	2.51 (0.23)	28 7/8" (734)	7.39 (0.69)
ADH1850	2.64 (0.24)	15 3/16" (386)	25" (634)	4.34 (0.40)	2.72 (0.25)	24 7/8" (632)	7.92 (0.74)
ADH1854	2.85 (0.26)	15 3/16" (386)	27" (685)	4.69 (0.44)	2.94 (0.27)	20 7/8" (531)	8.46 (0.79)
ADH1858	3.06 (0.28)	15 3/16" (386)	29" (736)	5.04 (0.47)	3.15 (0.29)	16 7/8" (429)	8.99 (0.84)
ADH1860	3.27 (0.30)	15 3/16" (386)	31" (787)	5.39 (0.50)	3.36 (0.31)	12 7/8" (328)	9.52 (0.88)
ADH1864	3.48 (0.32)	15 3/16" (386)	33" (838)	5.74 (0.53)	3.56 (0.33)	8 7/8" (226)	10.06 (0.93)
ADH1868	3.69 (0.34)	15 3/16" (386)	35" (889)	6.09 (0.57)	3.78 (0.35)	4 7/8" (124)	10.59 (0.98)
ADH1874	4.11 (0.38)	15 3/16" (386)	39" (991)	6.79 (0.63)	4.20 (0.39)	10 3/8" (264)	11.66 (1.08)
ADH1880	4.53 (0.42)	15 3/16" (386)	43" (1092)	7.49 (0.70)	4.62 (0.43)	2 3/8" (60)	12.73 (1.18)
ADH2030	1.73 (0.16)	19 3/16" (488)	13" (330)	2.95 (0.27)	1.84 (0.17)	48 7/8" (1242)	5.69 (0.53)
ADH2034	2.00 (0.19)	19 3/16" (488)	15" (380)	3.41 (0.32)	2.11 (0.20)	44 7/8" (1140)	6.34 (0.59)
ADH2038	2.26 (0.21)	19 3/16" (488)	17" (431)	3.87 (0.36)	2.38 (0.22)	40 7/8" (1039)	6.98 (0.65)
ADH2040	2.53 (0.24)	19 3/16" (488)	19" (482)	4.33 (0.40)	2.64 (0.25)	36 7/8" (937)	7.63 (0.71)
ADH2044	2.80 (0.26)	19 3/16" (488)	21" (533)	4.80 (0.45)	2.91 (0.27)	32 7/8" (836)	8.27 (0.77)
ADH2048	3.06 (0.28)	19 3/16" (488)	23" (584)	5.26 (0.49)	3.18 (0.29)	28 7/8" (734)	8.92 (0.83)
ADH2050	3.33 (0.31)	19 3/16" (488)	25" (634)	5.72 (0.53)	3.44 (0.32)	24 7/8" (632)	9.57 (0.89)
ADH2054	3.60 (0.33)	19 3/16" (488)	27" (685)	6.18 (0.57)	3.71 (0.34)	20 7/8" (531)	10.21 (0.95)
ADH2058	3.86 (0.36)	19 3/16" (488)	29" (736)	6.64 (0.62)	3.98 (0.37)	16 7/8" (429)	10.86 (1.01)
ADH2060	4.13 (0.38)	19 3/16" (488)	31" (787)	7.10 (0.66)	4.24 (0.39)	12 7/8" (328)	11.50 (1.07)
ADH2064	4.40 (0.41)	19 3/16" (488)	33" (838)	7.56 (0.70)	4.50 (0.42)	8 7/8" (226)	12.15 (1.13)
ADH2068	4.66 (0.43)	19 3/16" (488)	35" (889)	8.02 (0.75)	4.77 (0.44)	4 7/8" (124)	12.80 (1.19)
ADH2074	5.20 (0.48)	19 3/16" (488)	39" (991)	8.95 (0.83)	5.30 (0.49)	10 3/8" (264)	14.09 (1.31)
ADH2080	5.73 (0.53)	19 3/16" (488)	43" (1092)	9.87 (0.92)	5.84 (0.54)	2 3/8" (60)	15.38 (1.43)
ADH2430	2.09 (0.19)	23 3/16" (589)	13" (330)	3.66 (0.34)	2.23 (0.21)	48 7/8" (1242)	6.67 (0.62)
ADH2434	2.41 (0.22)	23 3/16" (589)	15" (380)	4.24 (0.39)	2.55 (0.24)	44 7/8" (1140)	7.43 (0.69)
ADH2438	2.73 (0.25)	23 3/16" (589)	17" (431)	4.81 (0.45)	2.87 (0.27)	40 7/8" (1039)	8.18 (0.76)
ADH2440	3.06 (0.28)	23 3/16" (589)	19" (482)	5.38 (0.50)	3.19 (0.30)	36 7/8" (937)	8.94 (0.83)
ADH2444	3.38 (0.31)	23 3/16" (589)	21" (533)	5.95 (0.55)	3.51 (0.33)	32 7/8" (836)	9.70 (0.90)
ADH2448	3.70 (0.34)	23 3/16" (589)	23" (584)	6.52 (0.61)	3.84 (0.36)	28 7/8" (734)	10.46 (0.97)
ADH2450	4.02 (0.37)	23 3/16" (589)	25" (634)	7.10 (0.66)	4.16 (0.39)	24 7/8" (632)	11.21 (1.04)
ADH2454	4.35 (0.40)	23 3/16" (589)	27" (685)	7.67 (0.71)	4.48 (0.42)	20 7/8" (531)	11.97 (1.11)
ADH2458	4.67 (0.43)	23 3/16" (589)	29" (736)	8.24 (0.77)	4.80 (0.45)	16 7/8" (429)	12.73 (1.18)
ADH2460	4.99 (0.46)	23 3/16" (589)	31" (787)	8.81 (0.82)	5.13 (0.48)	12 7/8" (328)	13.48 (1.25)
ADH2464	5.31 (0.49)	23 3/16" (589)	33" (838)	9.39 (0.87)	5.44 (0.51)	8 7/8" (226)	14.24 (1.32)
ADH2468	5.63 (0.52)	23 3/16" (589)	35" (889)	9.96 (0.93)	5.76 (0.54)	4 7/8" (124)	15.00 (1.39)
ADH2474 ◊	6.28 (0.58)	23 3/16" (589)	39" (991)	11.10 (1.03)	6.41 (0.60)	10 3/8" (264)	16.51 (1.53)
ADH2480 ◊	6.92 (0.64)	23 3/16" (589)	43" (1092)	12.25 (1.14)	7.05 (0.66)	2 3/8" (60)	18.02 (1.67)
ADH2630	2.27 (0.21)	25 3/16" (640)	13" (330)	4.02 (0.37)	2.42 (0.22)	48 7/8" (1242)	7.16 (0.67)
ADH2634	2.62 (0.24)	25 3/16" (640)	15" (380)	4.65 (0.43)	2.77 (0.26)	44 7/8" (1140)	7.97 (0.74)
ADH2638	2.97 (0.28)	25 3/16" (640)	17" (431)	5.27 (0.49)	3.12 (0.29)	40 7/8" (1039)	8.79 (0.82)
ADH2640	3.32 (0.31)	25 3/16" (640)	19" (482)	5.90 (0.55)	3.47 (0.32)	36 7/8" (937)	9.60 (0.89)
ADH2644	3.67 (0.34)	25 3/16" (640)	21" (533)	6.53 (0.61)	3.82 (0.35)	32 7/8" (836)	10.41 (0.97)
ADH2648	4.02 (0.37)	25 3/16" (640)	23" (584)	7.16 (0.66)	4.17 (0.39)	28 7/8" (734)	11.22 (1.04)
ADH2650	4.37 (0.41)	25 3/16" (640)	25" (634)	7.79 (0.72)	4.52 (0.42)	24 7/8" (632)	12.04 (1.12)
ADH2654	4.72 (0.44)	25 3/16" (640)	27" (685)	8.41 (0.78)	4.87 (0.45)	20 7/8" (531)	12.85 (1.19)
ADH2658	5.07 (0.47)	25 3/16" (640)	29" (736)	9.04 (0.84)	5.22 (0.48)	16 7/8" (429)	13.66 (1.27)
ADH2660	5.42 (0.50)	25 3/16" (640)	31" (787)	9.67 (0.90)	5.57 (0.52)	12 7/8" (328)	14.47 (1.34)
ADH2664 ◊	5.77 (0.54)	25 3/16" (640)	33" (838)	10.30 (0.96)	5.91 (0.55)	8 7/8" (226)	15.29 (1.42)
ADH2668 ◊	6.12 (0.57)	25 3/16" (640)	35" (889)	10.92 (1.01)	6.26 (0.58)	4 7/8" (124)	16.10 (1.50)
ADH2674 ◊	6.82 (0.63)	25 3/16" (640)	39" (991)	12.18 (1.13)	6.96 (0.65)	10 3/8" (264)	17.72 (1.65)
ADH2680 ◊	7.52 (0.70)	25 3/16" (640)	43" (1092)	13.44 (1.25)	7.66 (0.71)	2 3/8" (60)	19.35 (1.80)
ADH2830	2.45 (0.23)	27 3/16" (691)	13" (330)	4.37 (0.41)	2.61 (0.24)	48 7/8" (1242)	7.65 (0.71)
ADH2834	2.83 (0.26)	27 3/16" (691)	15" (380)	5.06 (0.47)	2.99 (0.28)	44 7/8" (1140)	8.52 (0.79)

* "Top of Subfloor to Top of Inside Sill Stop" is calculated based upon a structural header height of 6'-10 1/2" (2096) except for units greater than 81 3/4" (2076) in height that are calculated using a header height of 8' (2438).

◊ Meets or exceeds clear opening area of 5.7 sq. ft. or 0.53 m², clear opening width of 20" (508) and clear opening height of 24" (610).

continued on next page

Double-Hung Window Opening and Area Specifications *(continued)*

Window Number	Clear Opening Area Sq. Ft./ (m ²)		Clear Opening in Full Open Position		Glass Area Sq. Ft./ (m ²)	Vent Area Sq. Ft./ (m ²)		Top of Subfloor to Top of Inside Sill Stop Inches/ (mm)	Overall Window Area Sq. Ft./ (m ²)	
			Width Inches/ (mm)	Height Inches/ (mm)						
ADH2838	3.21	(0.30)	27 3/16" (691)	17" (431)	5.74 (0.53)	3.37 (0.31)	40 7/8" (1039)	9.39 (0.87)		
ADH2840	3.58 (0.33)	27 3/16" (691)	19" (482)	6.42 (0.60)	3.74 (0.35)	36 7/8" (937)	10.25 (0.95)			
ADH2844	3.96 (0.37)	27 3/16" (691)	21" (533)	7.11 (0.66)	4.12 (0.38)	32 7/8" (836)	11.12 (1.03)			
ADH2848	4.34 (0.40)	27 3/16" (691)	23" (584)	7.79 (0.72)	4.50 (0.42)	28 7/8" (734)	11.99 (1.11)			
ADH2850	4.72 (0.44)	27 3/16" (691)	25" (634)	8.47 (0.79)	4.88 (0.45)	24 7/8" (632)	12.86 (1.19)			
ADH2854	5.10 (0.47)	27 3/16" (691)	27" (685)	9.16 (0.85)	5.25 (0.49)	20 7/8" (531)	13.73 (1.28)			
ADH2858	5.47 (0.51)	27 3/16" (691)	29" (736)	9.84 (0.91)	5.63 (0.52)	16 7/8" (429)	14.59 (1.36)			
ADH2860 ◊	5.85 (0.54)	27 3/16" (691)	31" (787)	10.52 (0.98)	6.01 (0.56)	12 7/8" (328)	15.46 (1.44)			
ADH2864 ◊	6.23 (0.58)	27 3/16" (691)	33" (838)	11.21 (1.04)	6.38 (0.59)	8 7/8" (226)	16.33 (1.52)			
ADH2868 ◊	6.61 (0.61)	27 3/16" (691)	35" (889)	11.89 (1.10)	6.76 (0.63)	4 7/8" (124)	17.20 (1.60)			
ADH2874 ◊	7.36 (0.68)	27 3/16" (691)	39" (991)	13.26 (1.23)	7.51 (0.70)	10 3/8" (264)	18.93 (1.76)			
ADH2880 ◊	8.12 (0.75)	27 3/16" (691)	43" (1092)	14.62 (1.36)	8.27 (0.77)	2 3/8" (60)	20.67 (1.92)			
ADH21030	2.63 (0.24)	29 3/16" (742)	13" (330)	4.73 (0.44)	2.80 (0.26)	48 7/8" (1242)	8.14 (0.76)			
ADH21034	3.04 (0.28)	29 3/16" (742)	15" (380)	5.47 (0.51)	3.21 (0.30)	44 7/8" (1140)	9.06 (0.84)			
ADH21038	3.44 (0.32)	29 3/16" (742)	17" (431)	6.21 (0.58)	3.61 (0.34)	40 7/8" (1039)	9.99 (0.93)			
ADH21040	3.85 (0.36)	29 3/16" (742)	19" (482)	6.95 (0.65)	4.02 (0.37)	36 7/8" (937)	10.91 (1.01)			
ADH21044	4.25 (0.40)	29 3/16" (742)	21" (533)	7.69 (0.71)	4.42 (0.41)	32 7/8" (836)	11.83 (1.10)			
ADH21048	4.66 (0.43)	29 3/16" (742)	23" (584)	8.42 (0.78)	4.83 (0.45)	28 7/8" (734)	12.76 (1.19)			
ADH21050	5.06 (0.47)	29 3/16" (742)	25" (634)	9.16 (0.85)	5.24 (0.49)	24 7/8" (632)	13.68 (1.27)			
ADH21054	5.47 (0.51)	29 3/16" (742)	27" (685)	9.90 (0.92)	5.64 (0.52)	20 7/8" (531)	14.60 (1.36)			
ADH21058 ◊	5.88 (0.55)	29 3/16" (742)	29" (736)	10.64 (0.99)	6.05 (0.56)	16 7/8" (429)	15.53 (1.44)			
ADH21060 ◊	6.28 (0.58)	29 3/16" (742)	31" (787)	11.38 (1.06)	6.45 (0.60)	12 7/8" (328)	16.45 (1.53)			
ADH21064 ◊	6.69 (0.62)	29 3/16" (742)	33" (838)	12.12 (1.13)	6.85 (0.64)	8 7/8" (226)	17.38 (1.61)			
ADH21068 ◊	7.09 (0.66)	29 3/16" (742)	35" (889)	12.86 (1.19)	7.25 (0.67)	4 7/8" (124)	18.30 (1.70)			
ADH21074 ◊	7.90 (0.73)	29 3/16" (742)	39" (991)	14.34 (1.33)	8.07 (0.75)	10 3/8" (264)	20.15 (1.87)			
ADH21080 ◊	8.71 (0.81)	29 3/16" (742)	43" (1092)	15.81 (1.47)	8.88 (0.82)	2 3/8" (60)	21.99 (2.04)			
ADH3030	2.81 (0.26)	31 3/16" (792)	13" (330)	5.09 (0.47)	2.99 (0.28)	48 7/8" (1242)	8.63 (0.80)			
ADH3034	3.25 (0.30)	31 3/16" (792)	15" (380)	5.88 (0.55)	3.43 (0.32)	44 7/8" (1140)	9.61 (0.89)			
ADH3038	3.68 (0.34)	31 3/16" (792)	17" (431)	6.67 (0.62)	3.86 (0.36)	40 7/8" (1039)	10.59 (0.98)			
ADH3040	4.11 (0.38)	31 3/16" (792)	19" (482)	7.47 (0.69)	4.29 (0.40)	36 7/8" (937)	11.57 (1.07)			
ADH3044	4.54 (0.42)	31 3/16" (792)	21" (533)	8.26 (0.77)	4.73 (0.44)	32 7/8" (836)	12.55 (1.17)			
ADH3048	4.98 (0.46)	31 3/16" (792)	23" (584)	9.06 (0.84)	5.16 (0.48)	28 7/8" (734)	13.52 (1.26)			
ADH3050	5.41 (0.50)	31 3/16" (792)	25" (634)	9.85 (0.92)	5.59 (0.52)	24 7/8" (632)	14.50 (1.35)			
ADH3054 ◊	5.84 (0.54)	31 3/16" (792)	27" (685)	10.65 (0.99)	6.03 (0.56)	20 7/8" (531)	15.48 (1.44)			
ADH3058 ◊	6.28 (0.58)	31 3/16" (792)	29" (736)	11.44 (1.06)	6.46 (0.60)	16 7/8" (429)	16.46 (1.53)			
ADH3060 ◊	6.71 (0.62)	31 3/16" (792)	31" (787)	12.24 (1.14)	6.89 (0.64)	12 7/8" (328)	17.44 (1.62)			
ADH3064 ◊	7.14 (0.66)	31 3/16" (792)	33" (838)	13.03 (1.21)	7.32 (0.68)	8 7/8" (226)	18.42 (1.71)			
ADH3068 ◊	7.58 (0.70)	31 3/16" (792)	35" (889)	13.82 (1.28)	7.75 (0.72)	4 7/8" (124)	19.40 (1.80)			
ADH3074 ◊	8.44 (0.78)	31 3/16" (792)	39" (991)	15.41 (1.43)	8.62 (0.80)	10 3/8" (264)	21.36 (1.98)			
ADH3080 ◊	9.31 (0.86)	31 3/16" (792)	43" (1092)	17.00 (1.58)	9.48 (0.88)	2 3/8" (60)	23.32 (2.17)			
ADH3230	2.99 (0.28)	33 3/16" (843)	13" (330)	5.44 (0.51)	3.19 (0.30)	48 7/8" (1242)	9.12 (0.85)			
ADH3234	3.45 (0.32)	33 3/16" (843)	15" (380)	6.29 (0.58)	3.65 (0.34)	44 7/8" (1140)	10.15 (0.94)			
ADH3238	3.91 (0.36)	33 3/16" (843)	17" (431)	7.14 (0.66)	4.11 (0.38)	40 7/8" (1039)	11.19 (1.04)			
ADH3240	4.38 (0.41)	33 3/16" (843)	19" (482)	7.99 (0.74)	4.57 (0.42)	36 7/8" (937)	12.22 (1.14)			
ADH3244	4.84 (0.45)	33 3/16" (843)	21" (533)	8.84 (0.82)	5.03 (0.47)	32 7/8" (836)	13.26 (1.23)			
ADH3248	5.30 (0.49)	33 3/16" (843)	23" (584)	9.69 (0.90)	5.49 (0.51)	28 7/8" (734)	14.29 (1.33)			
ADH3250 ◊	5.76 (0.53)	33 3/16" (843)	25" (634)	10.54 (0.98)	5.95 (0.55)	24 7/8" (632)	15.33 (1.42)			
ADH3254 ◊	6.22 (0.58)	33 3/16" (843)	27" (685)	11.39 (1.06)	6.41 (0.60)	20 7/8" (531)	16.36 (1.52)			
ADH3258 ◊	6.68 (0.62)	33 3/16" (843)	29" (736)	12.24 (1.14)	6.87 (0.64)	16 7/8" (429)	17.40 (1.62)			
ADH3260 ◊	7.14 (0.66)	33 3/16" (843)	31" (787)	13.09 (1.22)	7.34 (0.68)	12 7/8" (328)	18.43 (1.71)			
ADH3264 ◊	7.60 (0.71)	33 3/16" (843)	33" (838)	13.94 (1.30)	7.79 (0.72)	8 7/8" (226)	19.47 (1.81)			
ADH3268 ◊	8.06 (0.75)	33 3/16" (843)	35" (889)	14.79 (1.37)	8.25 (0.77)	4 7/8" (124)	20.50 (1.90)			
ADH3274 ◊	8.99 (0.83)	33 3/16" (843)	39" (991)	16.49 (1.53)	9.17 (0.85)	10 3/8" (264)	22.57 (2.10)			
ADH3280 ◊	9.91 (0.92)	33 3/16" (843)	43" (1092)	18.19 (1.69)	10.09 (0.94)	2 3/8" (60)	24.64 (2.29)			
ADH3430	3.17 (0.29)	35 3/16" (894)	13" (330)	5.80 (0.54)	3.38 (0.31)	48 7/8" (1242)	9.61 (0.89)			
ADH3434	3.66 (0.34)	35 3/16" (894)	15" (380)	6.70 (0.62)	3.87 (0.36)	44 7/8" (1140)	10.70 (0.99)			
ADH3438	4.15 (0.39)	35 3/16" (894)	17" (431)	7.61 (0.71)	4.36 (0.40)	40 7/8" (1039)	11.79 (1.10)			
ADH3440	4.64 (0.43)	35 3/16" (894)	19" (482)	8.51 (0.79)	4.84 (0.45)	36 7/8" (937)	12.88 (1.20)			

* "Top of Subfloor to Top of Inside Sill Stop" is calculated based upon a structural header height of 6'-10 1/2" (2096) except for units greater than 81 3/4" (2076) in height that are calculated using a header height of 8' (2438). *continued on next page*
 • Dimensions in parentheses are in millimeters or square meters.
 ◊ Meets or exceeds clear opening area of 5.7 sq. ft. or 0.53 m², clear opening width of 20" (508) and clear opening height of 24" (610).

A-Series Double-Hung Windows

DOUBLE-HUNG WINDOWS

Double-Hung Window Opening and Area Specifications (continued)

Window Number	Clear Opening Area Sq. Ft./ (m ²)	Clear Opening in Full Open Position		Glass Area Sq. Ft./ (m ²)	Vent Area Sq. Ft./ (m ²)	Top of Subfloor to Top of Inside Sill Stop Inches/(mm)	Overall Window Area Sq. Ft./ (m ²)
		Width Inches/(mm)	Height Inches/(mm)				
ADH3444	5.13 (0.48)	35 3/16" (894)	21" (533)	9.42 (0.87)	5.33 (0.50)	32 7/8" (836)	13.97 (1.30)
ADH3448	5.62 (0.52)	35 3/16" (894)	23" (584)	10.32 (0.96)	5.82 (0.54)	28 7/8" (734)	15.06 (1.40)
ADH3450 ◊	6.11 (0.57)	35 3/16" (894)	25" (634)	11.23 (1.04)	6.31 (0.59)	24 7/8" (632)	16.15 (1.50)
ADH3454 ◊	6.59 (0.61)	35 3/16" (894)	27" (685)	12.14 (1.13)	6.80 (0.63)	20 7/8" (531)	17.24 (1.60)
ADH3458 ◊	7.08 (0.66)	35 3/16" (894)	29" (736)	13.04 (1.21)	7.29 (0.68)	16 7/8" (429)	18.33 (1.70)
ADH3460 ◊	7.57 (0.70)	35 3/16" (894)	31" (787)	13.95 (1.30)	7.78 (0.72)	12 7/8" (328)	19.42 (1.80)
ADH3464 ◊	8.06 (0.75)	35 3/16" (894)	33" (838)	14.85 (1.38)	8.26 (0.77)	8 7/8" (226)	20.51 (1.91)
ADH3468 ◊	8.55 (0.79)	35 3/16" (894)	35" (889)	15.76 (1.46)	8.74 (0.81)	4 7/8" (124)	21.60 (2.01)
ADH3474 ◊	9.53 (0.89)	35 3/16" (894)	39" (991)	17.57 (1.63)	9.72 (0.90)	10 3/8" (264)	23.78 (2.21)
ADH3480 ◊	10.50 (0.98)	35 3/16" (894)	43" (1092)	19.38 (1.80)	10.70 (0.99)	2 3/8" (60)	25.96 (2.41)
ADH3830	3.53 (0.33)	39 3/16" (996)	13" (330)	6.51 (0.60)	3.76 (0.35)	48 7/8" (1242)	10.59 (0.98)
ADH3834	4.08 (0.38)	39 3/16" (996)	15" (380)	7.52 (0.70)	4.31 (0.40)	44 7/8" (1140)	11.79 (1.10)
ADH3838	4.62 (0.43)	39 3/16" (996)	17" (431)	8.54 (0.79)	4.85 (0.45)	40 7/8" (1039)	12.99 (1.21)
ADH3840	5.17 (0.48)	39 3/16" (996)	19" (482)	9.56 (0.89)	5.40 (0.50)	36 7/8" (937)	14.19 (1.32)
ADH3844	5.71 (0.53)	39 3/16" (996)	21" (533)	10.57 (0.98)	5.94 (0.55)	32 7/8" (836)	15.39 (1.43)
ADH3848	6.25 (0.58)	39 3/16" (996)	23" (584)	11.59 (1.08)	6.48 (0.60)	28 7/8" (734)	16.59 (1.54)
ADH3850 ◊	6.80 (0.63)	39 3/16" (996)	25" (634)	12.61 (1.17)	7.03 (0.65)	24 7/8" (632)	17.80 (1.65)
ADH3854 ◊	7.34 (0.68)	39 3/16" (996)	27" (685)	13.62 (1.27)	7.57 (0.70)	20 7/8" (531)	19.00 (1.76)
ADH3858 ◊	7.89 (0.73)	39 3/16" (996)	29" (736)	14.64 (1.36)	8.12 (0.75)	16 7/8" (429)	20.20 (1.88)
ADH3860 ◊	8.43 (0.78)	39 3/16" (996)	31" (787)	15.66 (1.45)	8.66 (0.80)	12 7/8" (328)	21.40 (1.99)
ADH3864 ◊	8.98 (0.83)	39 3/16" (996)	33" (838)	16.67 (1.55)	9.19 (0.85)	8 7/8" (226)	22.60 (2.10)
ADH3868 ◊	9.52 (0.88)	39 3/16" (996)	35" (889)	17.69 (1.64)	9.74 (0.90)	4 7/8" (124)	23.80 (2.21)
ADH3874 ◊	10.61 (0.99)	39 3/16" (996)	39" (991)	19.72 (1.83)	10.83 (1.01)	10 3/8" (264)	26.21 (2.43)
ADH3880 ◊	11.70 (1.09)	39 3/16" (996)	43" (1092)	21.76 (2.02)	11.92 (1.11)	2 3/8" (60)	28.61 (2.66)
ADH4030	3.89 (0.36)	43 3/16" (1097)	13" (330)	7.22 (0.67)	4.15 (0.39)	48 7/8" (1242)	11.57 (1.07)
ADH4034	4.49 (0.42)	43 3/16" (1097)	15" (380)	8.35 (0.78)	4.75 (0.44)	44 7/8" (1140)	12.88 (1.20)
ADH4038	5.09 (0.47)	43 3/16" (1097)	17" (431)	9.47 (0.88)	5.35 (0.50)	40 7/8" (1039)	14.19 (1.32)
ADH4040	5.69 (0.53)	43 3/16" (1097)	19" (482)	10.60 (0.98)	5.95 (0.55)	36 7/8" (937)	15.50 (1.44)
ADH4044	6.29 (0.58)	43 3/16" (1097)	21" (533)	11.73 (1.09)	6.55 (0.61)	32 7/8" (836)	16.82 (1.56)
ADH4048	6.89 (0.64)	43 3/16" (1097)	23" (584)	12.86 (1.19)	7.15 (0.66)	28 7/8" (734)	18.13 (1.68)
ADH4050 ◊	7.49 (0.70)	43 3/16" (1097)	25" (634)	13.99 (1.30)	7.75 (0.72)	24 7/8" (632)	19.44 (1.81)
ADH4054 ◊	8.09 (0.75)	43 3/16" (1097)	27" (685)	15.11 (1.40)	8.35 (0.78)	20 7/8" (531)	20.75 (1.93)
ADH4058 ◊	8.69 (0.81)	43 3/16" (1097)	29" (736)	16.24 (1.51)	8.95 (0.83)	16 7/8" (429)	22.07 (2.05)
ADH4060 ◊	9.29 (0.86)	43 3/16" (1097)	31" (787)	17.37 (1.61)	9.55 (0.89)	12 7/8" (328)	23.38 (2.17)
ADH4064 ◊	9.89 (0.92)	43 3/16" (1097)	33" (838)	18.50 (1.72)	10.13 (0.94)	8 7/8" (226)	24.96 (2.29)
ADH4068 ◊	10.49 (0.97)	43 3/16" (1097)	35" (889)	19.62 (1.82)	10.73 (1.00)	4 7/8" (124)	26.00 (2.42)
ADH4074 ◊	11.69 (1.09)	43 3/16" (1097)	39" (991)	21.88 (2.03)	11.93 (1.11)	10 3/8" (264)	28.63 (2.66)
ADH4080 ◊	12.89 (1.20)	43 3/16" (1097)	43" (1092)	24.14 (2.24)	13.13 (1.22)	2 3/8" (60)	31.25 (2.90)

* "Top of Subfloor to Top of Inside Sill Stop" is calculated based upon a structural header height of 6'-10 1/2" (2096) except for units greater than 81 3/4" (2076) in height that are calculated using a header height of 8' (2438).

* Dimensions in parentheses are in millimeters or square meters.

◊ Meets or exceeds clear opening area of 5.7 sq. ft. or 0.53 m², clear opening width of 20" (508) and clear opening height of 24" (610).

Grille Patterns

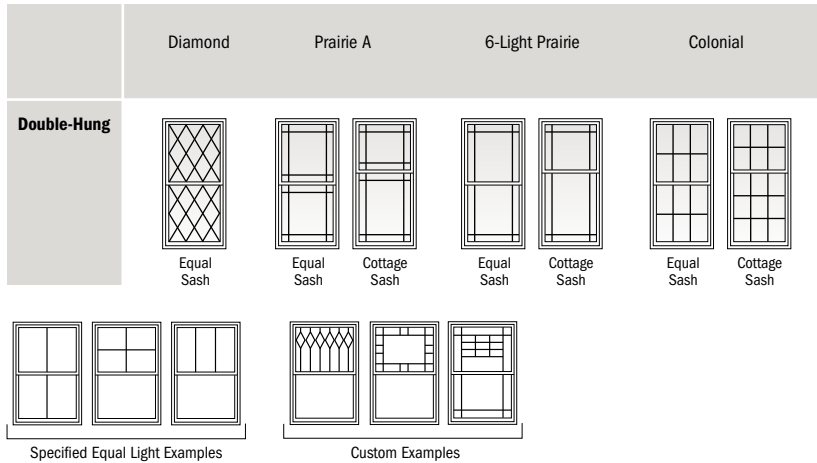

Double-hung window patterns are also available in Upper Sash Only (USO) configurations. For picture window patterns that require alignment with double-hung patterns, identify the double-hung sash style (equal, cottage, reverse cottage) when ordering. **Number of lights and overall pattern varies with window size. Patterns may not be available in all configurations or sizes.** Specified equal light and custom patterns are also available. Some restrictions apply. For more grille options, see page 19 or visit andersenwindows.com/grilles.

Double-Hung Window Details

Scale 1 1/2" (38) = 1'-0" (305) – 1:8

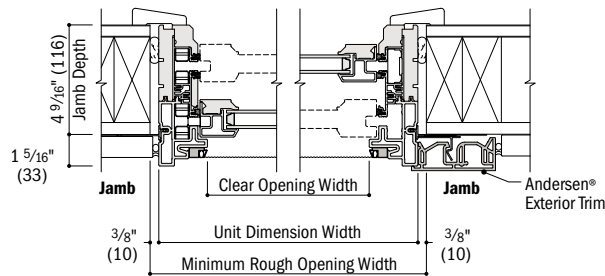

Horizontal Section

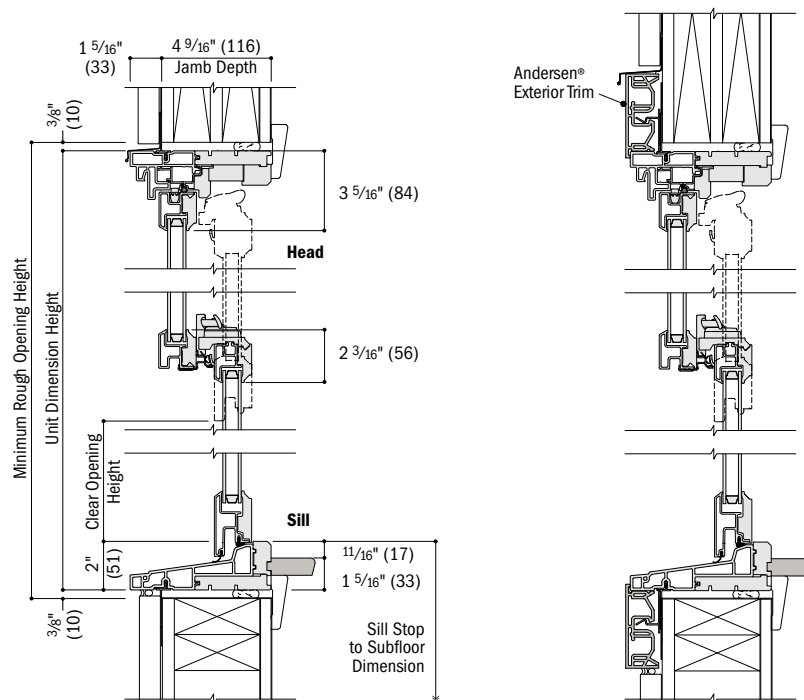

Vertical Section

Vertical Section

See pages 60-62 for joining details.

- 4 9/16" (116) base jamb depth measurement is from back side of installation flange.
- Light-colored areas are parts included with window. Dark-colored areas are additional Andersen® parts required to complete window assembly as shown.
- Dimensions in parentheses are in millimeters.
- **Minimum rough openings may need to be increased to allow for use of building wraps, flashing, sill panning, brackets, fasteners or other items. See installation information on pages 226-227.**
- Details are for illustration only and are not intended to represent product installation methods or materials. Refer to product installation instructions at andersenwindows.com.

PICTURE WINDOWS

Table of Picture Window Sizes

Scale 1/8" (3) = 1'-0" (305) – 1:96

Notes on the next page also apply to this page.

Window Dimension	1'-3 1/4"	1'-7 1/4"	1'-11 1/4"	2'-3 1/4"	2'-5 1/4"	2'-7 1/4"	2'-9 1/4"	2'-11 1/4"	3'-1 1/4"	3'-3 1/4"	3'-7 1/4"	3'-11 1/4"
	(387)	(489)	(591)	(692)	(743)	(794)	(845)	(895)	(946)	(997)	(1099)	(1200)
Minimum Rough Opening	1'-4"	1'-8"	2'-0"	2'-4"	2'-6"	2'-8"	2'-10"	3'-0"	3'-2"	3'-4"	3'-8"	4'-0"
	(406)	(508)	(610)	(711)	(762)	(813)	(864)	(914)	(965)	(1016)	(1118)	(1219)
Unobstructed Glass	8 5/8"	12 5/8"	16 5/8"	20 5/8"	22 5/8"	24 5/8"	26 5/8"	28 5/8"	30 5/8"	32 5/8"	36 5/8"	40 5/8"
	(219)	(321)	(422)	(524)	(575)	(625)	(676)	(727)	(778)	(829)	(930)	(1032)

CUSTOM WIDTHS – 15 1/4" to 95 1/4" (largest dimensions are 95 1/4" x 71 1/4" or 71 1/4" x 95 1/4")

CUSTOM HEIGHTS – 15 1/4" to 95 1/4"	CUSTOM WIDTHS – 15 1/4" to 95 1/4"											
	APW1420	APW1820	APW2020	APW2420	APW2620	APW2820	APW21020	APW3020	APW3220	APW3420	APW3820	APW4020
1'-11 1/4" (591)												
2'-3 1/4" (692)												
2'-7 1/4" (794)												
2'-11 1/4" (895)												
3'-3 1/4" (997)												
3'-7 1/4" (1099)												
3'-11 1/4" (1200)												
4'-3 1/4" (1302)												
4'-7 1/4" (1403)												
4'-11 1/4" (1505)												
5'-3 1/4" (1607)												
5'-7 1/4" (1708)												
5'-11 1/4" (1810)												

4'-3 1/4" (1302)	4'-7 1/4" (1403)	4'-11 1/4" (1505)	5'-3 1/4" (1607)	5'-7 1/4" (1708)	5'-11 1/4" (1810)	6'-3 1/4" (1911)
4'-4" (1321)	4'-8" (1422)	5'-0" (1524)	5'-4" (1626)	5'-8" (1727)	6'-0" (1829)	6'-4" (1930)
44 5/8" (1133)	48 5/8" (1335)	52 5/8" (1337)	56 5/8" (1438)	60 5/8" (1540)	64 5/8" (1641)	68 5/8" (1743)

 APW4420	 APW4820	 APW5020	 APW5420	 APW5820	 APW6020	 APW6420
 APW4424	 APW4824	 APW5024	 APW5424	 APW5824	 APW6024	 APW6424
 APW4428	 APW4828	 APW5028	 APW5428	 APW5828	 APW6028	 APW6428
 APW4430	 APW4830	 APW5030	 APW5430	 APW5830	 APW6030	 APW6430
 APW4434	 APW4834	 APW5034	 APW5434	 APW5834	 APW6034	 APW6434
 APW4438	 APW4838	 APW5038	 APW5438	 APW5838	 APW6038	 APW6438
 APW4440	 APW4840	 APW5040	 APW5440	 APW5840	 APW6040	 APW6440
 APW4444	 APW4844	 APW5044	 APW5444	 APW5844	 APW6044	 APW6444
 APW4448	 APW4848	 APW5048	 APW5448	 APW5848	 APW6048	 APW6448
 APW4450	 APW4850	 APW5050	 APW5450	 APW5850	 APW6050	 APW6450
 APW4454	 APW4854	 APW5054	 APW5454	 APW5854	 APW6054	 APW6454
 APW4458	 APW4858	 APW5058	 APW5458	 APW5858	 APW6058	 APW6458
 APW4460	 APW4860	 APW5060	 APW5460	 APW5860	 APW6060	 APW6460



Custom-size windows are available in 1/8" (3) increments. See page 65 for custom sizes and specifications.

All sizes shown are available with PG upgrade[‡]

Picture window must be installed as shown and should not be rotated. Tall bottom rail is designed to align with bottom rail of double-hung and casement windows.

Grille patterns shown on page 46. Details shown on page 51.

* "Window Dimension" always refers to outside frame-to-frame dimension.
 • "Minimum Rough Opening" dimensions may need to be increased to allow for use of building wraps, flashing, sill panning, brackets, fasteners or other items. See pages 226-227 for more details.
 • Dimensions in parentheses are in millimeters.
 ‡ PG upgrade is not available for custom sizes equal to or less than 19 1/4" (489) wide and tall.

continued on next page

PICTURE WINDOWS

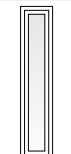
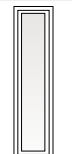









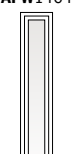
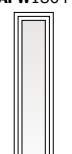

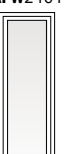
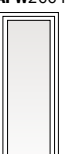







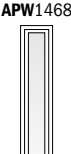
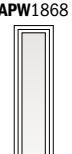
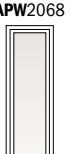
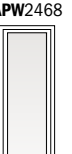
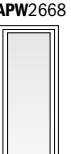



















Table of Picture Window Sizes (continued)

Notes on the next page also apply to this page.

Scale 1/8" (3) = 1'-0" (305) – 1:96











Window Dimension	1'-3 1/4" (387)	1'-7 1/4" (489)	1'-11 1/4" (591)	2'-3 1/4" (692)	2'-5 1/4" (743)	2'-7 1/4" (794)	2'-9 1/4" (845)	2'-11 1/4" (895)	3'-1 1/4" (946)	3'-3 1/4" (997)	3'-7 1/4" (1099)	3'-11 1/4" (1200)
Minimum Rough Opening	1'-4" (406)	1'-8" (508)	2'-0" (610)	2'-4" (711)	2'-6" (762)	2'-8" (813)	2'-10" (864)	3'-0" (914)	3'-2" (965)	3'-4" (1016)	3'-8" (1118)	4'-0" (1219)
Unobstructed Glass	8 5/8" (219)	12 5/8" (321)	16 5/8" (422)	20 5/8" (524)	22 5/8" (575)	24 5/8" (625)	26 5/8" (676)	28 5/8" (727)	30 5/8" (778)	32 5/8" (829)	36 5/8" (930)	40 5/8" (1032)

CUSTOM WIDTHS – 15 1/4" to 95 1/4" (largest dimensions are 95 1/4" x 71 1/4" or 71 1/4" x 95 1/4")

<p>6'-3 1/4" (1911)</p> <p>6'-4" (1930)</p> <p>6'-7 1/4" (2013)</p> <p>6'-8" (2032)</p> <p>7'-3 1/4" (2216)</p> <p>7'-4" (2235)</p> <p>7'-11 1/4" (2419)</p> <p>8'-0" (2438)</p>	<p>CUSTOM HEIGHTS – 15 1/4" to 95 1/4"</p>	 APW1464	 APW1864	 APW2064	 APW2464	 APW2664	 APW2864	 APW21064	 APW3064	 APW3264	 APW3464	 APW3864	 APW4064
		 APW1468	 APW1868	 APW2068	 APW2468	 APW2668	 APW2868	 APW21068	 APW3068	 APW3268	 APW3468	 APW3868	 APW4068
		 APW1474	 APW1874	 APW2074	 APW2474	 APW2674	 APW2874	 APW21074	 APW3074	 APW3274	 APW3474	 APW3874	 APW4074
		 APW1480	 APW1880	 APW2080	 APW2480	 APW2680	 APW2880	 APW21080	 APW3080	 APW3280	 APW3480	 APW3880	 APW4080

- *"Window Dimension" always refers to outside frame-to-frame dimension.
- *"Minimum Rough Opening" dimensions may need to be increased to allow for use of building wraps, flashing, sill panning, brackets, fasteners or other items. See pages 226-227 for more details.
- *Dimensions in parentheses are in millimeters.
- *PG upgrade is not available for custom sizes equal to or less than 19 1/4" (489) wide and tall.

Grille Patterns

	Queen Anne	Diamond	Prairie A	Specified Equal Light with Simulated Check Rail	Colonial	Modified Colonial	Modified Colonial with Simulated Check Rail	Tall Fractional	Tall Fractional with Simulated Check Rail	Short Fractional	Short Fractional with Simulated Check Rail
Picture											

For picture window patterns that require alignment with double-hung patterns, identify the double-hung sash style (equal, cottage, reverse cottage) when ordering. **Number of lights and overall pattern varies with window size. Patterns may not be available in all configurations or sizes.** Specified equal light, specified equal light fractional and custom patterns are also available. For more grille options, see page 19 or visit andersenwindows.com/grilles.

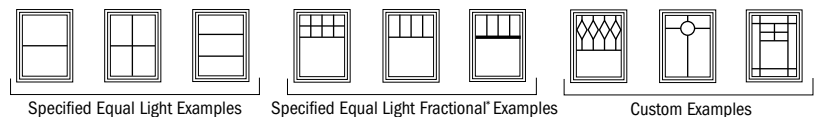

*Bottom horizontal bar located at center or at custom dimensions.

4'-3 1/4" (1302)	4'-7 1/4" (1403)	4'-11 1/4" (1505)	5'-3 1/4" (1607)	5'-7 1/4" (1708)	5'-11 1/4" (1810)
4'-4" (1321)	4'-8" (1422)	5'-0" (1524)	5'-4" (1626)	5'-8" (1727)	6'-0" (1829)
44 5/8" (1133)	48 5/8" (1335)	52 5/8" (1337)	56 5/8" (1438)	60 5/8" (1540)	64 5/8" (1641)



continued on next page



Custom-size windows are available in 1/8" (3) increments. See page 65 for custom sizes and specifications.

All sizes shown are available with PG upgrade.†

Picture window must be installed as shown and should not be rotated. Tall bottom rail is designed to align with bottom rail of double-hung and casement windows.

Grille patterns shown on page 46.
Details shown on page 51.

* "Window Dimension" always refers to outside frame-to-frame dimension.
 • **"Minimum Rough Opening" dimensions may need to be increased to allow for use of building wraps, flashing, sill panning, brackets, fasteners or other items. See pages 226-227 for more details.**
 • Dimensions in parentheses are in millimeters.
 †PG upgrade is not available for custom sizes equal to or less than 19 1/4" (489) wide and tall.
 *Tempered glass required. Some visual distortion may occur.

PICTURE WINDOWS

Table of Picture Window Sizes (continued)

Scale 1/8" (3) = 1'-0" (305) – 1:96

Window Dimension	6'-7 1/4" (2013)	6'-11 1/4" (2115)	7'-3 1/4" (2216)	7'-7 1/4" (2318)	7'-11 1/4" (2419)
Minimum Rough Opening	6'-8" (2032)	7'-0" (2133)	7'-4" (2235)	7'-8" (2336)	8'-0" (2438)
Unobstructed Glass	72 5/8" (1845)	76 5/8" (1946)	80 5/8" (2048)	84 5/8" (2149)	88 5/8" (2251)

Window Dimension	CUSTOM WIDTHS – 15 1/4" to 95 1/4" (largest dimensions are 95 1/4" x 71 1/4" or 71 1/4" x 95 1/4")				
	15 1/4" (391)	19 1/4" (491)	23 1/4" (591)	27 1/4" (691)	31 1/4" (791)
1'-11 1/4" (591)	APW6820	APW7020	APW7420	APW7820	APW8020
2'-3 1/4" (692)	APW6824	APW7024	APW7424	APW7824	APW8024
2'-7 1/4" (794)	APW6828	APW7028	APW7428	APW7828	APW8028
2'-11 1/4" (895)	APW6830	APW7030	APW7430	APW7830	APW8030
3'-3 1/4" (997)	APW6834	APW7034	APW7434	APW7834	APW8034
3'-7 1/4" (1099)	APW6838	APW7038	APW7438	APW7838	APW8038
3'-11 1/4" (1200)	APW6840	APW7040	APW7440	APW7840	APW8040
4'-3 1/4" (1302)	APW6844	APW7044	APW7444	APW7844	APW8044
4'-7 1/4" (1403)	APW6848	APW7048	APW7448	APW7848	APW8048
4'-11 1/4" (1505)	APW6850	APW7050	APW7450	APW7850	APW8050*
5'-3 1/4" (1607)	APW6854	APW7054	APW7454	APW7854*	APW8054*
5'-7 1/4" (1708)	APW6858	APW7058	APW7458*	APW7858*	APW8058*
5'-11 1/4" (1810)	APW6860	APW7060*	APW7460*	APW7860*	APW8060*



Custom-size windows are available in 1/8" (3) increments. See page 65 for custom sizes and specifications.

All sizes shown are available with PG upgrade.†

Picture window must be installed as shown and should not be rotated. Tall bottom rail is designed to align with bottom rail of double-hung and casement windows.

Grille patterns shown on page 46. Details shown on page 51.

* "Window Dimension" always refers to outside frame-to-frame dimension.
 † "Minimum Rough Opening" dimensions may need to be increased to allow for use of building wraps, flashing, sill panning, brackets, fasteners or other items. See pages 226-227 for more details.
 • Dimensions in parentheses are in millimeters.
 † PG upgrade is not available for custom sizes equal to or less than 19 1/4" (489) wide and tall.
 * Tempered glass required. Some visual distortion may occur.

Picture Window Area Specifications

Window Number	Glass Area Sq. Ft./ (m ²)	Overall Window Area Sq. Ft./ (m ²)
APW1420	0.94 (0.09)	2.46 (0.23)
APW1424	1.18 (0.11)	2.89 (0.27)
APW1428	1.42 (0.13)	3.31 (0.31)
APW1430	1.66 (0.15)	3.73 (0.35)
APW1434	1.90 (0.18)	4.16 (0.39)
APW1438	2.14 (0.20)	4.58 (0.43)
APW1440	2.38 (0.22)	5.00 (0.46)
APW1444	2.62 (0.24)	5.43 (0.50)
APW1448	2.85 (0.26)	5.85 (0.54)
APW1450	3.09 (0.29)	6.27 (0.58)
APW1454	3.33 (0.31)	6.70 (0.62)
APW1458	3.57 (0.33)	7.12 (0.66)
APW1460	3.81 (0.35)	7.55 (0.70)
APW1464	4.05 (0.38)	7.97 (0.74)
APW1468	4.29 (0.40)	8.39 (0.78)
APW1474	4.77 (0.44)	9.24 (0.86)
APW1480	5.24 (0.49)	10.09 (0.94)
APW1820	1.38 (0.13)	3.11 (0.29)
APW1824	1.73 (0.16)	3.64 (0.34)
APW1828	2.08 (0.19)	4.18 (0.39)
APW1830	2.43 (0.23)	4.71 (0.44)
APW1834	2.78 (0.26)	5.25 (0.49)
APW1838	3.13 (0.29)	5.78 (0.54)
APW1840	3.48 (0.32)	6.32 (0.59)
APW1844	3.83 (0.36)	6.85 (0.64)
APW1848	4.18 (0.39)	7.39 (0.69)
APW1850	4.53 (0.42)	7.92 (0.74)
APW1854	4.88 (0.45)	8.46 (0.79)
APW1858	5.23 (0.49)	8.99 (0.84)
APW1860	5.58 (0.52)	9.52 (0.88)
APW1864	5.93 (0.55)	10.06 (0.93)
APW1868	6.28 (0.58)	10.59 (0.98)
APW1874	6.98 (0.65)	11.66 (1.08)
APW1880	7.68 (0.71)	12.73 (1.18)
APW2020	1.82 (0.17)	3.75 (0.35)
APW2024	2.28 (0.21)	4.40 (0.41)
APW2028	2.74 (0.25)	5.05 (0.47)
APW2030	3.20 (0.30)	5.69 (0.53)
APW2034	3.67 (0.34)	6.34 (0.59)
APW2038	4.13 (0.38)	6.98 (0.65)
APW2040	4.59 (0.43)	7.63 (0.71)
APW2044	5.05 (0.47)	8.27 (0.77)
APW2048	5.51 (0.51)	8.92 (0.83)
APW2050	5.97 (0.55)	9.57 (0.89)
APW2054	6.43 (0.60)	10.21 (0.95)
APW2058	6.89 (0.64)	10.86 (1.01)
APW2060	7.35 (0.68)	11.50 (1.07)
APW2064	7.82 (0.73)	12.15 (1.13)
APW2068	8.28 (0.77)	12.80 (1.19)
APW2074	9.20 (0.85)	14.09 (1.31)
APW2080	10.12 (0.94)	15.38 (1.43)
APW2420	2.26 (0.21)	4.40 (0.41)
APW2424	2.83 (0.26)	5.16 (0.48)
APW2428	3.40 (0.32)	5.91 (0.55)
APW2430	3.98 (0.37)	6.67 (0.62)
APW2434	4.55 (0.42)	7.43 (0.69)
APW2438	5.12 (0.48)	8.18 (0.76)
APW2440	5.69 (0.53)	8.94 (0.83)
APW2444	6.27 (0.58)	9.70 (0.90)
APW2448	6.84 (0.64)	10.46 (0.97)
APW2450	7.41 (0.69)	11.21 (1.04)

Window Number	Glass Area Sq. Ft./ (m ²)	Overall Window Area Sq. Ft./ (m ²)
APW2454	7.98 (0.74)	11.97 (1.11)
APW2458	8.55 (0.79)	12.73 (1.18)
APW2460	9.13 (0.85)	13.48 (1.25)
APW2464	9.70 (0.90)	14.24 (1.32)
APW2468	10.27 (0.95)	15.00 (1.39)
APW2474	11.42 (1.06)	16.51 (1.53)
APW2480	12.56 (1.17)	18.02 (1.67)
APW2620	2.48 (0.23)	4.72 (0.44)
APW2624	3.11 (0.29)	5.54 (0.51)
APW2628	3.74 (0.35)	6.35 (0.59)
APW2630	4.36 (0.41)	7.16 (0.67)
APW2634	4.99 (0.46)	7.97 (0.74)
APW2638	5.62 (0.52)	8.79 (0.82)
APW2640	6.25 (0.58)	9.60 (0.89)
APW2644	6.87 (0.64)	10.41 (0.97)
APW2648	7.50 (0.70)	11.22 (1.04)
APW2650	8.13 (0.76)	12.04 (1.12)
APW2654	8.76 (0.81)	12.85 (1.19)
APW2658	9.39 (0.87)	13.66 (1.27)
APW2660	10.01 (0.93)	14.47 (1.34)
APW2664	10.64 (0.99)	15.29 (1.42)
APW2668	11.27 (1.05)	16.10 (1.50)
APW2674	12.52 (1.16)	17.72 (1.65)
APW2680	13.78 (1.28)	19.35 (1.80)
APW2820	2.70 (0.25)	5.05 (0.47)
APW2824	3.38 (0.31)	5.91 (0.55)
APW2828	4.07 (0.38)	6.78 (0.63)
APW2830	4.75 (0.44)	7.65 (0.71)
APW2834	5.43 (0.50)	8.52 (0.79)
APW2838	6.12 (0.57)	9.39 (0.87)
APW2840	6.80 (0.63)	10.25 (0.95)
APW2844	7.48 (0.69)	11.12 (1.03)
APW2848	8.17 (0.76)	11.99 (1.11)
APW2850	8.85 (0.82)	12.86 (1.19)
APW2854	9.53 (0.89)	13.73 (1.28)
APW2858	10.22 (0.95)	14.59 (1.36)
APW2860	10.90 (1.01)	15.46 (1.44)
APW2864	11.58 (1.08)	16.33 (1.52)
APW2868	12.27 (1.14)	17.20 (1.60)
APW2874	13.63 (1.27)	18.93 (1.76)
APW2880	15.00 (1.39)	20.67 (1.92)
APW21020	2.92 (0.27)	5.37 (0.50)
APW21024	3.66 (0.34)	6.29 (0.58)
APW21024	3.66 (0.34)	6.29 (0.58)
APW21028	4.40 (0.41)	7.22 (0.67)
APW21030	5.14 (0.48)	8.14 (0.76)
APW21034	5.87 (0.55)	9.06 (0.84)
APW21038	6.61 (0.61)	9.99 (0.93)
APW21040	7.35 (0.68)	10.91 (1.01)
APW21044	8.09 (0.75)	11.83 (1.10)
APW21048	8.83 (0.82)	12.76 (1.19)
APW21050	9.57 (0.89)	13.68 (1.27)
APW21054	10.31 (0.96)	14.60 (1.36)
APW21058	11.05 (1.03)	15.53 (1.44)
APW21060	11.79 (1.10)	16.45 (1.53)
APW21064	12.52 (1.16)	17.38 (1.61)
APW21068	13.26 (1.23)	18.30 (1.70)
APW21074	14.74 (1.37)	20.15 (1.87)
APW21080	16.22 (1.51)	21.99 (2.04)
APW3020	3.14 (0.29)	5.69 (0.53)
APW3024	3.93 (0.37)	6.67 (0.62)

Window Number	Glass Area Sq. Ft./ (m ²)	Overall Window Area Sq. Ft./ (m ²)
APW3028	4.73 (0.44)	7.65 (0.71)
APW3030	5.52 (0.51)	8.63 (0.80)
APW3034	6.32 (0.59)	9.61 (0.89)
APW3038	7.11 (0.66)	10.59 (0.98)
APW3040	7.90 (0.73)	11.57 (1.07)
APW3044	8.70 (0.81)	12.55 (1.17)
APW3044	8.70 (0.81)	12.55 (1.17)
APW3048	9.49 (0.88)	13.52 (1.26)
APW3050	10.29 (0.96)	14.50 (1.35)
APW3054	11.08 (1.03)	15.48 (1.44)
APW3058	11.88 (1.10)	16.46 (1.53)
APW3060	12.67 (1.18)	17.44 (1.62)
APW3064	13.47 (1.25)	18.42 (1.71)
APW3068	14.26 (1.32)	19.40 (1.80)
APW3074	15.85 (1.47)	21.36 (1.98)
APW3080	17.44 (1.62)	23.32 (2.17)
APW3220	3.36 (0.31)	6.01 (0.56)
APW3224	4.21 (0.39)	7.05 (0.65)
APW3228	5.06 (0.47)	8.08 (0.75)
APW3230	5.91 (0.55)	9.12 (0.85)
APW3234	6.76 (0.63)	10.15 (0.94)
APW3238	7.61 (0.71)	11.19 (1.04)
APW3240	8.46 (0.79)	12.22 (1.14)
APW3244	9.31 (0.86)	13.26 (1.23)
APW3248	10.16 (0.94)	14.29 (1.33)
APW3250	11.01 (1.02)	15.33 (1.42)
APW3254	11.86 (1.10)	16.36 (1.52)
APW3258	12.71 (1.18)	17.40 (1.62)
APW3260	13.56 (1.26)	18.43 (1.71)
APW3264	14.41 (1.34)	19.47 (1.81)
APW3268	15.26 (1.42)	20.50 (1.90)
APW3274	16.96 (1.58)	22.57 (2.10)
APW3280	18.66 (1.73)	24.64 (2.29)
APW3420	3.58 (0.33)	6.34 (0.59)
APW3424	4.48 (0.42)	7.43 (0.69)
APW3428	5.39 (0.50)	8.52 (0.79)
APW3430	6.29 (0.58)	9.61 (0.89)
APW3434	7.20 (0.67)	10.70 (0.99)
APW3438	8.10 (0.75)	11.79 (1.10)
APW3440	9.01 (0.84)	12.88 (1.20)
APW3444	9.92 (0.92)	13.97 (1.30)
APW3448	10.82 (1.01)	15.06 (1.40)
APW3450	11.73 (1.09)	16.15 (1.50)
APW3454	12.63 (1.17)	17.24 (1.60)
APW3458	13.54 (1.26)	18.33 (1.70)
APW3460	14.44 (1.34)	19.42 (1.80)
APW3464	15.35 (1.43)	20.51 (1.91)
APW3468	16.25 (1.51)	21.60 (2.01)
APW3474	18.07 (1.68)	23.78 (2.21)
APW3480	19.88 (1.85)	25.96 (2.41)
APW3820	4.02 (0.37)	6.98 (0.65)
APW3824	5.03 (0.47)	8.18 (0.76)
APW3828	6.05 (0.56)	9.39 (0.87)
APW3830	7.07 (0.66)	10.59 (0.98)
APW3834	8.08 (0.75)	11.79 (1.10)
APW3838	9.10 (0.85)	12.99 (1.21)
APW3840	10.12 (0.94)	14.19 (1.32)
APW3844	11.13 (1.03)	15.39 (1.43)
APW3848	12.15 (1.13)	16.59 (1.54)
APW3850	13.17 (1.22)	17.80 (1.65)

*Dimensions in parentheses are in square meters.

continued on next page

A-Series Picture Windows

PICTURE WINDOWS

Picture Window Area Specifications *(continued)*

Window Number	Glass Area Sq. Ft./ (m ²)	Overall Window Area Sq. Ft./ (m ²)
APW3854	14.18 (1.32)	19.00 (1.77)
APW3858	15.20 (1.41)	20.20 (1.88)
APW3860	16.22 (1.51)	21.40 (1.99)
APW3864	17.23 (1.60)	22.60 (2.10)
APW3868	18.25 (1.70)	23.80 (2.21)
APW3874	20.28 (1.88)	26.21 (2.43)
APW3880	22.32 (2.07)	28.61 (2.66)
APW4020	4.45 (0.41)	7.63 (0.71)
APW4024	5.58 (0.52)	8.94 (0.83)
APW4028	6.71 (0.62)	10.25 (0.95)
APW4030	7.84 (0.73)	11.57 (1.07)
APW4034	8.97 (0.83)	12.88 (1.20)
APW4038	10.09 (0.94)	14.19 (1.32)
APW4040	11.22 (1.04)	15.50 (1.44)
APW4044	12.35 (1.15)	16.82 (1.56)
APW4048	13.48 (1.25)	18.13 (1.68)
APW4050	14.60 (1.36)	19.44 (1.81)
APW4054	15.73 (1.46)	20.75 (1.93)
APW4058	16.86 (1.57)	22.07 (2.05)
APW4060	17.99 (1.67)	23.38 (2.17)
APW4064	19.12 (1.78)	24.69 (2.29)
APW4068	20.24 (1.88)	26.00 (2.42)
APW4074	22.50 (2.09)	28.63 (2.66)
APW4080	24.75 (2.30)	31.25 (2.90)
APW4420	4.89 (0.45)	8.27 (0.77)
APW4424	6.13 (0.57)	9.70 (0.90)
APW4428	7.37 (0.68)	11.12 (1.03)
APW4430	8.61 (0.80)	12.55 (1.17)
APW4434	9.85 (0.92)	13.97 (1.30)
APW4438	11.09 (1.03)	15.39 (1.43)
APW4440	12.33 (1.15)	16.82 (1.56)
APW4444	13.57 (1.26)	18.24 (1.69)
APW4448	14.80 (1.37)	19.66 (1.83)
APW4450	16.04 (1.49)	21.09 (1.96)
APW4454	17.28 (1.61)	22.51 (2.09)
APW4458	18.52 (1.72)	23.93 (2.22)
APW4460	19.76 (1.84)	25.36 (2.36)
APW4464	21.00 (1.95)	26.78 (2.49)
APW4468	22.24 (2.07)	28.21 (2.62)
APW4474	24.72 (2.30)	31.05 (2.88)
APW4480	27.19 (2.53)	33.90 (3.15)
APW4820	5.33 (0.50)	8.92 (0.83)
APW4824	6.68 (0.62)	10.46 (0.97)
APW4828	8.03 (0.75)	11.99 (1.11)
APW4830	9.38 (0.87)	13.52 (1.26)
APW4834	10.73 (1.00)	15.06 (1.40)
APW4838	12.08 (1.12)	16.59 (1.54)
APW4840	13.43 (1.25)	18.13 (1.68)
APW4844	14.78 (1.37)	19.66 (1.83)
APW4848	16.13 (1.50)	21.20 (1.97)
APW4850	17.48 (1.62)	22.73 (2.11)
APW4854	18.83 (1.75)	24.27 (2.25)
APW4858	20.18 (1.87)	25.80 (2.40)
APW4860	21.53 (2.00)	27.34 (2.54)
APW4864	22.88 (2.13)	28.87 (2.68)
APW4868	24.23 (2.25)	30.41 (2.83)
APW4874	26.93 (2.50)	33.48 (3.11)
APW4880	29.63 (2.75)	36.55 (3.40)
APW5020	5.77 (0.54)	9.57 (0.89)
APW5024	7.23 (0.67)	11.21 (1.04)
APW5028	8.69 (0.81)	12.86 (1.19)

Window Number	Glass Area Sq. Ft./ (m ²)	Overall Window Area Sq. Ft./ (m ²)
APW5030	10.15 (0.94)	14.50 (1.35)
APW5034	11.62 (1.08)	16.15 (1.50)
APW5038	13.08 (1.22)	17.80 (1.65)
APW5040	14.54 (1.35)	19.44 (1.81)
APW5044	16.00 (1.49)	21.09 (1.96)
APW5048	17.46 (1.62)	22.73 (2.11)
APW5050	18.92 (1.76)	24.38 (2.26)
APW5054	20.38 (1.89)	26.02 (2.42)
APW5058	21.84 (2.03)	27.67 (2.57)
APW5060	23.30 (2.16)	29.32 (2.72)
APW5064	24.77 (2.30)	30.96 (2.88)
APW5068	26.23 (2.44)	32.61 (3.03)
APW5074	29.15 (2.71)	35.90 (3.34)
APW5080	32.07 (2.98)	39.19 (3.64)
APW5420	6.21 (0.58)	10.21 (0.95)
APW5424	7.78 (0.72)	11.97 (1.11)
APW5428	9.35 (0.87)	13.73 (1.28)
APW5430	10.93 (1.02)	15.48 (1.44)
APW5434	12.50 (1.16)	17.24 (1.60)
APW5438	14.07 (1.31)	19.00 (1.77)
APW5440	15.64 (1.45)	20.75 (1.93)
APW5444	17.22 (1.60)	22.51 (2.09)
APW5448	18.79 (1.75)	24.27 (2.25)
APW5450	20.36 (1.89)	26.02 (2.42)
APW5454	21.93 (2.04)	27.78 (2.58)
APW5458	23.50 (2.18)	29.54 (2.74)
APW5460	25.08 (2.33)	31.30 (2.91)
APW5464	26.65 (2.48)	33.05 (3.07)
APW5468	28.22 (2.62)	34.81 (3.23)
APW5474	31.37 (2.91)	38.32 (3.56)
APW5480	34.51 (3.21)	41.84 (3.89)
APW5820	6.65 (0.62)	10.86 (1.01)
APW5824	8.33 (0.77)	12.73 (1.18)
APW5828	10.02 (0.93)	14.59 (1.36)
APW5830	11.70 (1.09)	16.46 (1.53)
APW5834	13.38 (1.24)	18.33 (1.70)
APW5838	15.07 (1.40)	20.20 (1.88)
APW5840	16.75 (1.56)	22.07 (2.05)
APW5844	18.43 (1.71)	23.93 (2.22)
APW5848	20.12 (1.87)	25.80 (2.40)
APW5850	21.80 (2.03)	27.67 (2.57)
APW5854	23.48 (2.18)	29.54 (2.74)
APW5858	25.17 (2.34)	31.41 (2.92)
APW5860	26.85 (2.49)	33.27 (3.09)
APW5864	28.53 (2.65)	35.14 (3.26)
APW5868	30.22 (2.81)	37.01 (3.44)
APW5874	33.58 (3.12)	40.75 (3.79)
APW5880	36.95 (3.43)	44.48 (4.13)
APW6020	7.09 (0.66)	11.50 (1.07)
APW6024	8.88 (0.82)	13.48 (1.25)
APW6028	10.68 (0.99)	15.46 (1.44)
APW6030	12.47 (1.16)	17.44 (1.62)
APW6034	14.27 (1.33)	19.42 (1.80)
APW6038	16.06 (1.49)	21.40 (1.99)
APW6040	17.85 (1.66)	23.38 (2.17)
APW6044	19.65 (1.83)	25.36 (2.36)
APW6048	21.44 (1.99)	27.34 (2.54)
APW6050	23.24 (2.16)	29.32 (2.72)
APW6054	25.03 (2.33)	31.30 (2.91)
APW6058	26.83 (2.49)	33.27 (3.09)
APW6060	28.62 (2.66)	35.25 (3.27)

Window Number	Glass Area Sq. Ft./ (m ²)	Overall Window Area Sq. Ft./ (m ²)
APW6064	30.42 (2.83)	37.23 (3.46)
APW6068	32.21 (2.99)	39.21 (3.64)
APW6074	35.80 (3.33)	43.17 (4.01)
APW6080	39.39 (3.66)	47.13 (4.38)
APW6420	7.53 (0.70)	12.15 (1.13)
APW6424	9.43 (0.88)	14.24 (1.32)
APW6428	11.34 (1.05)	16.33 (1.52)
APW6430	13.24 (1.23)	18.42 (1.71)
APW6434	15.15 (1.41)	20.51 (1.91)
APW6438	17.05 (1.58)	22.60 (2.10)
APW6440	18.96 (1.76)	24.69 (2.29)
APW6444	20.87 (1.94)	26.78 (2.49)
APW6448	22.77 (2.12)	28.87 (2.68)
APW6450	24.68 (2.29)	30.96 (2.88)
APW6454	26.58 (2.47)	33.05 (3.07)
APW6458	28.49 (2.65)	35.14 (3.26)
APW6460	30.39 (2.82)	37.23 (3.46)
APW6820	7.97 (0.74)	12.80 (1.19)
APW6824	9.98 (0.98)	15.00 (1.39)
APW6828	12.00 (1.11)	17.20 (1.60)
APW6830	14.02 (1.30)	19.40 (1.80)
APW6834	16.03 (1.49)	21.60 (2.01)
APW6838	18.05 (1.68)	23.80 (2.21)
APW6840	20.07 (1.86)	26.00 (2.42)
APW6844	22.08 (2.05)	28.20 (2.62)
APW6848	24.10 (2.24)	30.40 (2.82)
APW6850	26.12 (2.43)	32.61 (3.03)
APW6854	28.13 (2.61)	34.81 (3.23)
APW6858	30.15 (2.80)	37.01 (3.44)
APW6860	32.17 (2.99)	39.21 (3.64)
APW7020	8.40 (0.78)	13.44 (1.25)
APW7024	10.53 (0.98)	15.75 (1.46)
APW7028	12.66 (1.18)	18.07 (1.68)
APW7030	14.79 (1.37)	20.38 (1.89)
APW7034	16.92 (1.57)	22.69 (2.11)
APW7038	19.04 (1.77)	25.00 (2.32)
APW7040	21.17 (1.97)	27.32 (2.54)
APW7044	23.30 (2.16)	29.63 (2.75)
APW7048	25.43 (2.36)	31.94 (2.97)
APW7050	27.55 (2.56)	34.25 (3.18)
APW7054	29.68 (2.76)	36.57 (3.40)
APW7058	31.81 (2.96)	38.88 (3.61)
APW7060	33.94 (3.15)	41.19 (3.83)
APW7420	8.84 (0.82)	14.09 (1.31)
APW7424	11.08 (1.03)	16.51 (1.53)
APW7428	13.32 (1.24)	18.93 (1.76)
APW7430	15.56 (1.45)	21.36 (1.98)
APW7434	17.80 (1.65)	23.78 (2.21)
APW7438	20.04 (1.86)	26.21 (2.43)
APW7440	22.28 (2.07)	28.63 (2.66)
APW7444	24.52 (2.28)	31.05 (2.88)
APW7448	26.75 (2.49)	33.48 (3.11)
APW7450	29.00 (2.69)	35.90 (3.34)
APW7454	31.23 (2.90)	38.32 (3.56)
APW7458	33.47 (3.11)	40.75 (3.79)
APW7460	35.71 (3.32)	43.17 (4.01)
APW7820	9.28 (0.86)	14.73 (1.37)
APW7824	11.63 (1.08)	17.26 (1.60)
APW7828	13.98 (1.30)	19.80 (1.84)

* Dimensions in parentheses are in square meters.

continued on next page

Picture Window Area Specifications *(continued)*

Window Number	Glass Area Sq. Ft./ (m ²)	Overall Window Area Sq. Ft./ (m ²)
APW7830	16.33 (1.52)	22.34 (2.08)
APW7834	18.68 (1.74)	24.87 (2.31)
APW7838	21.03 (1.95)	27.41 (2.55)
APW7840	23.38 (2.17)	29.94 (2.78)
APW7844	25.73 (2.39)	32.48 (3.02)
APW7848	28.08 (2.61)	35.01 (3.25)
APW7850	30.43 (2.83)	37.55 (3.49)
APW7854	32.78 (3.05)	40.08 (3.72)
APW7858	35.13 (3.26)	42.62 (3.96)
APW7860	37.48 (3.48)	45.15 (4.19)
APW8020	9.72 (0.90)	15.38 (1.43)
APW8024	12.18 (1.13)	18.02 (1.67)
APW8028	14.64 (1.36)	20.67 (1.92)
APW8030	17.10 (1.59)	23.32 (2.17)
APW8034	19.57 (1.82)	25.96 (2.41)
APW8038	22.03 (2.05)	28.61 (2.66)
APW8040	24.49 (2.28)	31.25 (2.90)
APW8044	26.95 (2.50)	33.90 (3.15)
APW8048	29.41 (2.73)	36.55 (3.40)
APW8050	31.87 (2.96)	39.19 (3.64)
APW8054	34.33 (3.19)	41.84 (3.89)
APW8058	36.79 (3.42)	44.48 (4.13)
APW8060	39.25 (3.65)	47.13 (4.38)

*Dimensions in parentheses are in square meters.

Picture Window Details

Scale 1 1/2" (38) = 1'-0" (305) – 1:8

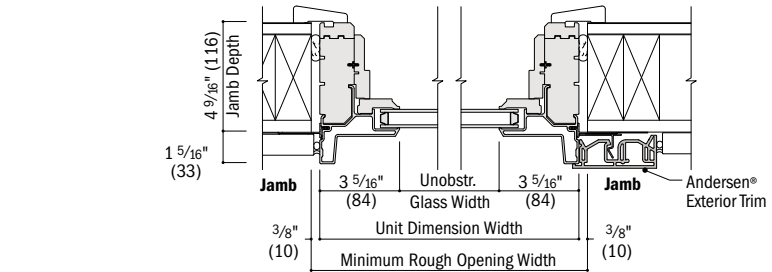

Horizontal Section

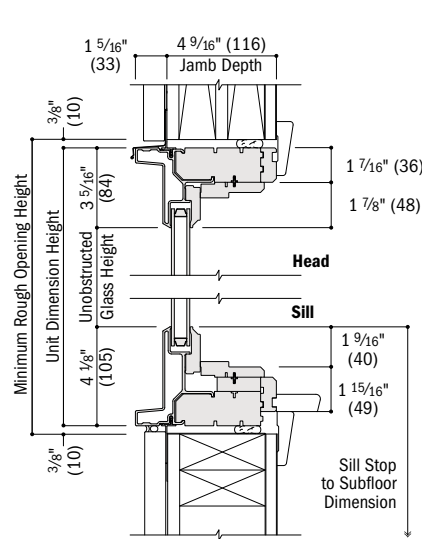

Vertical Section

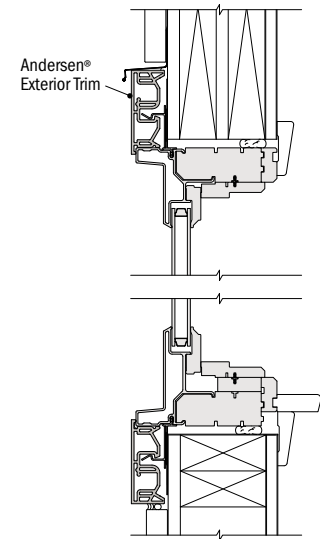

Vertical Section

See pages 60-62 for joining details.

- 4 9/16" (116) base jamb depth measurement is from back side of installation flange.
- Light-colored areas are parts included with window. Dark-colored areas are additional Andersen® parts required to complete window assembly as shown.
- Dimensions in parentheses are in millimeters.
- **Minimum rough openings may need to be increased to allow for use of building wraps, flashing, sill panning, brackets, fasteners or other items. See installation information on pages 226-227.**
- Details are for illustration only and are not intended to represent product installation methods or materials. Refer to product installation instructions at andersenwindows.com.

TRANSOM WINDOWS

Table of Transom Window Sizes

Scale 1/8" (3) = 1'-0" (305) – 1:96

Notes on the next page also apply to this page.

Unit Dimension	1'-3 1/4"	1'-7 1/4"	1'-11 1/4"	2'-3 1/4"	2'-5 1/4"	2'-7 1/4"	2'-9 1/4"	2'-11 1/4"	3'-1 1/4"	3'-3 1/4"	3'-7 1/4"	3'-11 1/4"
Minimum Rough Opening	1'-4" (406)	1'-8" (508)	2'-0" (610)	2'-4" (711)	2'-6" (762)	2'-8" (813)	2'-10" (864)	3'-0" (914)	3'-2" (965)	3'-4" (1016)	3'-8" (1118)	4'-0" (1219)
Unobstructed Glass	8 5/8" (219)	12 5/8" (321)	16 5/8" (422)	20 5/8" (524)	22 5/8" (575)	24 5/8" (625)	26 5/8" (676)	28 5/8" (727)	30 5/8" (778)	32 5/8" (829)	36 5/8" (930)	40 5/8" (1032)

CUSTOM WIDTHS – fixed 15 1/4" to 95 1/4" (largest dimensions are 95 1/4" x 71 1/4" or 71 1/4" x 95 1/4")

CUSTOM HEIGHTS – fixed 11 1/4" to 95 1/4"	CUSTOM SIZES AVAILABLE – venting											
	ATF1410	ATF1810	ATF2010	ATF2410	ATF2610	ATF2810	ATF21010	ATF3010	ATF3210	ATF3410	ATF3810	ATF4010
11 1/4" (286)												
1'-3 1/4" (387)												
1'-5 1/4" (438)												
1'-7 1/4" (489)												
1'-9 1/4" (540)												
1'-11 1/4" (591)												
2'-1 1/4" (641)												
2'-3 1/4" (692)												
2'-5 1/4" (743)												
2'-7 1/4" (794)												

4'-3 1/4" (1302)	4'-7 1/4" (1403)	4'-11 1/4" (1505)	5'-3 1/4" (1607)	5'-7 1/4" (1708)	5'-11 1/4" (1810)
4'-4" (1321)	4'-8" (1422)	5'-0" (1524)	5'-4" (1626)	5'-8" (1727)	6'-0" (1829)
44 5/8" (1133)	48 5/8" (1335)	52 5/8" (1337)	56 5/8" (1438)	60 5/8" (1540)	64 5/8" (1641)

 ATF4410	 ATF4810	 ATF5010	 ATF5410	 ATF5810	 ATF6010
--	--	--	--	--	--

 ATF4414	 ATF4814	 ATF5014	 ATF5414	 ATF5814	 ATF6014
 ATV4414	 ATV4814	 ATV5014	 ATV5414	 ATV5814	 ATV6014
 ATF4416	 ATF4816	 ATF5016	 ATF5416	 ATF5816	 ATF6016
 ATV4416	 ATV4816	 ATV5016	 ATV5416	 ATV5816	 ATV6016
 ATF4418	 ATF4818	 ATF5018	 ATF5418	 ATF5818	 ATF6018
 ATV4418	 ATV4818	 ATV5018	 ATV5418	 ATV5818	 ATV6018
 ATF44110	 ATF48110	 ATF50110	 ATF54110	 ATF58110	 ATF60110
 ATV44110	 ATV48110	 ATV50110	 ATV54110	 ATV58110	 ATV60110
 ATF4420	 ATF4820	 ATF5020	 ATF5420	 ATF5820	 ATF6020
 ATV4420	 ATV4820	 ATV5020	 ATV5420	 ATV5820	 ATV6020
 ATF4422	 ATF4822	 ATF5022	 ATF5422	 ATF5822	 ATF6022
 ATV4422	 ATV4822	 ATV5022	 ATV5422	 ATV5822	 ATV6022
 ATF4424	 ATF4824	 ATF5024	 ATF5424	 ATF5824	 ATF6024
 ATV4424	 ATV4824	 ATV5024	 ATV5424	 ATV5824	 ATV6024
 ATF4426	 ATF4826	 ATF5026	 ATF5426	 ATF5826	 ATF6026
 ATV4426	 ATV4826	 ATV5026	 ATV5426	 ATV5826	 ATV6026
 ATF4428	 ATF4828	 ATF5028	 ATF5428	 ATF5828	 ATF6028
 ATV4428	 ATV4828	 ATV5028	 ATV5428	 ATV5828	 ATV6028



Custom-size windows are available in 1/8" (3) increments. See page 65 for custom sizes and specifications.



Fixed

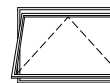

Venting

Choose fixed (**ATF**) or venting (**ATV**).

Most sizes shown are available with PG upgrade.†

Venting window must be installed to vent as shown, and should not be rotated and used as a hopper.

Grille patterns shown on page 58.

Details shown on page 59.

* "Window Dimension" always refers to outside frame-to-frame dimension.
 * "Minimum Rough Opening" dimensions may need to be increased to allow for use of building wraps, flashing, sill panning, brackets, fasteners or other items. See pages 226-227 for more details.
 † Dimensions in parentheses are in millimeters.
 ‡ PG upgrade is not available for fixed transom sizes **ATF1410** and **ATF1414** shown with an underscore on page 52.

continued on next page

TRANSOM WINDOWS

Table of Transom Window Sizes (continued)

Scale 1/8" (3) = 1'-0" (305) – 1:96

Notes on the next page also apply to this page.

Window Dimension	1'-3 1/4" (387)	1'-7 1/4" (489)	1'-11 1/4" (591)	2'-3 1/4" (692)	2'-5 1/4" (743)	2'-7 1/4" (794)	2'-9 1/4" (845)	2'-11 1/4" (895)	3'-1 1/4" (946)	3'-3 1/4" (997)	3'-7 1/4" (1099)	3'-11 1/4" (1200)
Minimum Rough Opening	1'-4" (406)	1'-8" (508)	2'-0" (610)	2'-4" (711)	2'-6" (762)	2'-8" (813)	2'-10" (864)	3'-0" (914)	3'-2" (965)	3'-4" (1016)	3'-8" (1118)	4'-0" (1219)
Unobstructed Glass	8 5/8" (219)	12 5/8" (321)	16 5/8" (422)	20 5/8" (524)	22 5/8" (575)	24 5/8" (625)	26 5/8" (676)	28 5/8" (727)	30 5/8" (778)	32 5/8" (829)	36 5/8" (930)	40 5/8" (1032)

CUSTOM SIZES AVAILABLE

CUSTOM AVAILABLE

2'-11 1/4" (895)
3'-0" (914)
28 5/8" (727)

3'-3 1/4" (997)
3'-4" (1016)
32 5/8" (829)

ATF1430 ATF1830 ATF2030 ATF2430 ATF2630 ATF2830 ATF21030 ATF3030 ATF3230 ATF3430 ATF3830 ATF4030

ATF1434 ATF1834 ATF2034 ATF2434 ATF2634 ATF2834 ATF21034 ATF3034 ATF3234 ATF3434 ATF3834 ATF4034

Fixed Transom Window Area Specifications

Window Number	Glass Area Sq. Ft./ (m ²)	Overall Window Area Sq. Ft./ (m ²)
ATF1410	0.27 (0.03)	1.19 (0.11)
ATF1414	0.51 (0.05)	1.62 (0.15)
ATF1416	0.63 (0.06)	1.83 (0.17)
ATF1418	0.75 (0.07)	2.04 (0.19)
ATF14110	0.87 (0.08)	2.25 (0.21)
ATF1420	0.99 (0.09)	2.46 (0.23)
ATF1422	1.11 (0.10)	2.67 (0.25)
ATF1424	1.23 (0.11)	2.89 (0.27)
ATF1426	1.35 (0.13)	3.10 (0.29)
ATF1428	1.47 (0.14)	3.31 (0.31)
ATF1430	1.71 (0.16)	3.73 (0.35)
ATF1434	1.95 (0.18)	4.16 (0.39)
ATF1810	0.40 (0.04)	1.50 (0.14)
ATF1814	0.75 (0.07)	2.04 (0.19)
ATF1816	0.93 (0.09)	2.31 (0.21)
ATF1818	1.10 (0.10)	2.57 (0.24)
ATF18110	1.28 (0.12)	2.84 (0.26)
ATF1820	1.45 (0.13)	3.11 (0.29)
ATF1822	1.63 (0.15)	3.38 (0.31)
ATF1824	1.80 (0.17)	3.64 (0.34)
ATF1826	1.98 (0.18)	3.91 (0.36)
ATF1828	2.15 (0.20)	4.18 (0.39)
ATF1830	2.50 (0.23)	4.71 (0.44)
ATF1834	2.85 (0.26)	5.25 (0.49)
ATF2010	0.53 (0.05)	1.82 (0.17)
ATF2014	0.99 (0.09)	2.46 (0.23)
ATF2016	1.22 (0.11)	2.79 (0.26)
ATF2018	1.45 (0.13)	3.11 (0.29)
ATF20110	1.68 (0.16)	3.43 (0.32)
ATF2020	1.91 (0.18)	3.75 (0.35)
ATF2022	2.14 (0.20)	4.08 (0.38)
ATF2024	2.37 (0.22)	4.40 (0.41)
ATF2026	2.61 (0.24)	4.72 (0.44)
ATF2028	2.84 (0.26)	5.05 (0.47)
ATF2030	3.30 (0.31)	5.69 (0.53)
ATF2034	3.76 (0.35)	6.34 (0.59)
ATF2410	0.66 (0.06)	2.13 (0.20)
ATF2414	1.23 (0.11)	2.89 (0.27)
ATF2416	1.52 (0.14)	3.26 (0.30)
ATF2418	1.80 (0.17)	3.64 (0.34)

* Dimensions in parentheses are in square meters.

Venting Transom Window Opening and Area Specifications

Window Number	Clear Opening in Full Open Position		Glass Area Sq. Ft./ (m ²)	Vent Sq. Ft./ (m ²)	Top of Subfloor to Top of Inside Sill Stop Inches/ (mm)	Overall Window Area Sq. Ft./ (m ²)
	Clear Opening Sq. Ft./ (m ²)	Width Inches/ (mm)				
ATV1814	0.59 (0.05)	14 5/16" (363)	5 7/8" (150)	0.75 (0.07)	59 1/2" (1764)	2.04 (0.19)
ATV2014	0.75 (0.07)	18 5/16" (465)	5 7/8" (150)	0.99 (0.09)	69 1/2" (1764)	2.46 (0.23)
ATV2414	0.91 (0.08)	22 5/16" (567)	5 7/8" (150)	1.23 (0.11)	69 1/2" (1764)	2.89 (0.27)
ATV2614	0.99 (0.09)	24 5/16" (617)	5 7/8" (150)	1.35 (0.13)	69 1/2" (1764)	3.10 (0.29)
ATV2814	1.08 (0.10)	26 5/16" (668)	5 7/8" (150)	1.47 (0.14)	69 1/2" (1764)	3.31 (0.31)
ATV21014	1.16 (0.11)	28 5/16" (719)	5 7/8" (150)	1.59 (0.15)	69 1/2" (1764)	3.52 (0.33)
ATV3014	1.24 (0.12)	30 5/16" (770)	5 7/8" (150)	1.71 (0.16)	69 1/2" (1764)	3.73 (0.35)
ATV3214	1.32 (0.12)	32 5/16" (821)	5 7/8" (150)	1.83 (0.17)	69 1/2" (1764)	3.95 (0.37)
ATV3414	1.40 (0.13)	34 5/16" (871)	5 7/8" (150)	1.95 (0.18)	69 1/2" (1764)	4.16 (0.39)
ATV3814	1.57 (0.15)	38 5/16" (973)	5 7/8" (150)	2.19 (0.20)	69 1/2" (1764)	4.58 (0.43)
ATV4014	1.73 (0.16)	42 5/16" (1075)	5 7/8" (150)	2.43 (0.23)	69 1/2" (1764)	5.00 (0.46)
ATV4414	1.90 (0.18)	46 5/16" (1176)	5 7/8" (150)	2.66 (0.25)	69 1/2" (1764)	5.43 (0.50)
ATV4814	2.06 (0.19)	50 5/16" (1278)	5 7/8" (150)	2.90 (0.27)	69 1/2" (1764)	5.85 (0.54)
ATV5014	2.22 (0.21)	54 5/16" (1379)	5 7/8" (150)	3.14 (0.29)	69 1/2" (1764)	6.28 (0.58)
ATV5414	2.39 (0.22)	58 5/16" (1481)	5 7/8" (150)	3.38 (0.31)	69 1/2" (1764)	6.70 (0.62)
ATV5814	2.55 (0.24)	62 5/16" (1538)	5 7/8" (150)	3.62 (0.34)	69 1/2" (1764)	7.12 (0.66)
ATV6014	2.71 (0.25)	66 5/16" (1684)	5 7/8" (150)	3.86 (0.36)	69 1/2" (1764)	7.55 (0.70)
ATV1816	0.59 (0.05)	14 5/16" (363)	5 7/8" (150)	0.93 (0.09)	67 1/2" (1714)	2.31 (0.21)
ATV2016	0.75 (0.07)	18 5/16" (465)	5 7/8" (150)	1.22 (0.11)	67 1/2" (1714)	2.79 (0.26)
ATV2416	0.91 (0.08)	22 5/16" (567)	5 7/8" (150)	1.52 (0.14)	67 1/2" (1714)	3.26 (0.30)
ATV2616	0.99 (0.09)	24 5/16" (617)	5 7/8" (150)	1.66 (0.15)	67 1/2" (1714)	3.50 (0.33)
ATV2816	1.08 (0.10)	26 5/16" (668)	5 7/8" (150)	1.81 (0.17)	67 1/2" (1714)	3.74 (0.35)
ATV21016	1.16 (0.11)	28 5/16" (719)	5 7/8" (150)	1.96 (0.18)	67 1/2" (1714)	3.98 (0.37)
ATV3016	1.24 (0.12)	30 5/16" (770)	5 7/8" (150)	2.11 (0.20)	67 1/2" (1714)	4.22 (0.39)
ATV3216	1.32 (0.12)	32 5/16" (821)	5 7/8" (150)	2.25 (0.21)	67 1/2" (1714)	4.46 (0.41)
ATV3416	1.40 (0.13)	34 5/16" (871)	5 7/8" (150)	2.40 (0.22)	67 1/2" (1714)	4.70 (0.44)
ATV3816	1.57 (0.15)	38 5/16" (973)	5 7/8" (150)	2.69 (0.25)	67 1/2" (1714)	5.18 (0.48)
ATV4016	1.73 (0.16)	42 5/16" (1075)	5 7/8" (150)	2.99 (0.28)	67 1/2" (1714)	5.66 (0.53)
ATV4416	1.90 (0.18)	46 5/16" (1176)	5 7/8" (150)	3.28 (0.30)	67 1/2" (1714)	6.14 (0.57)
ATV4816	2.06 (0.19)	50 5/16" (1278)	5 7/8" (150)	3.58 (0.33)	67 1/2" (1714)	6.62 (0.61)
ATV5016	2.22 (0.21)	54 5/16" (1379)	5 7/8" (150)	3.87 (0.36)	67 1/2" (1714)	7.10 (0.66)
ATV5416	2.39 (0.22)	58 5/16" (1481)	5 7/8" (150)	4.17 (0.39)	67 1/2" (1714)	7.58 (0.70)
ATV5816	2.55 (0.24)	62 5/16" (1538)	5 7/8" (150)	4.46 (0.41)	67 1/2" (1714)	8.06 (0.75)
ATV6016	2.71 (0.25)	66 5/16" (1684)	5 7/8" (150)	4.76 (0.44)	67 1/2" (1714)	8.54 (0.79)
ATV1818	0.59 (0.05)	14 5/16" (363)	5 7/8" (150)	1.10 (0.10)	65 1/2" (1663)	2.57 (0.24)
ATV2018	0.75 (0.07)	18 5/16" (465)	5 7/8" (150)	1.45 (0.13)	65 1/2" (1663)	3.11 (0.29)
ATV2418	0.91 (0.08)	22 5/16" (567)	5 7/8" (150)	1.80 (0.17)	65 1/2" (1663)	3.64 (0.34)
ATV2618	0.99 (0.09)	24 5/16" (617)	5 7/8" (150)	1.98 (0.18)	65 1/2" (1663)	3.91 (0.36)
ATV2818	1.08 (0.10)	26 5/16" (668)	5 7/8" (150)	2.15 (0.20)	65 1/2" (1663)	4.18 (0.39)
ATV21018	1.16 (0.11)	28 5/16" (719)	5 7/8" (150)	2.33 (0.22)	65 1/2" (1663)	4.45 (0.41)
ATV3018	1.24 (0.12)	30 5/16" (770)	5 7/8" (150)	2.50 (0.23)	65 1/2" (1663)	4.71 (0.44)
ATV3218	1.32 (0.12)	32 5/16" (821)	5 7/8" (150)	2.68 (0.25)	65 1/2" (1663)	4.98 (0.46)

* Top of Subfloor to Top of Inside Sill Stop" is calculated based upon a structural header height of 6'-10 1/2" (2096).

* Dimensions in parentheses are in millimeters or square meters.

continued on next page

4'-3 1/4" (1302)	4'-7 1/4" (1403)	4'-11 1/4" (1505)	5'-3 1/4" (1607)	5'-7 1/4" (1708)	5'-11 1/4" (1810)
4'-4" (1321)	4'-8" (1422)	5'-0" (1524)	5'-4" (1626)	5'-8" (1727)	6'-0" (1829)
44 5/8" (1133)	48 5/8" (1335)	52 5/8" (1337)	56 5/8" (1438)	60 5/8" (1540)	64 5/8" (1641)

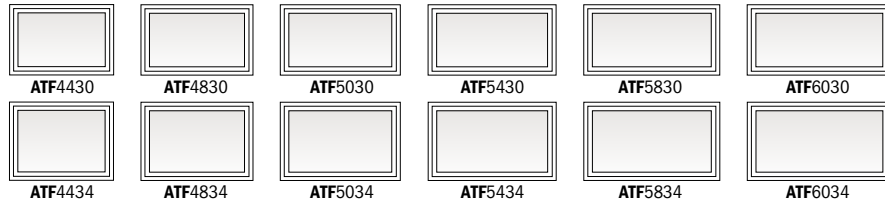

• "Window Dimension" always refers to outside frame-to-frame dimension.
 • "Minimum Rough Opening" dimensions may need to be increased to allow for use of building wraps, flashing, sill panning, brackets, fasteners or other items. See pages 226-227 for more details.
 • Dimensions in parentheses are in millimeters.
 †PG upgrade is not available for fixed transom sizes ATF1410 and ATF1414 shown with an underscore on page 52.

Custom-size windows are available in 1/8" (3) increments. See page 65 for custom sizes and specifications. Choose fixed (ATF) or venting (ATV). Most sizes shown are available with PG upgrade.† Venting sizes shown on pages 52-53. Grille patterns shown on page 58. Details shown on page 59.

Fixed Transom Window Area Specifications (continued)

Window Number	Glass Area Sq. Ft./ (m ²)	Overall Window Area Sq. Ft./ (m ²)
ATF24110	2.09 (0.19)	4.02 (0.37)
ATF2420	2.37 (0.22)	4.40 (0.41)
ATF2422	2.66 (0.25)	4.78 (0.44)
ATF2424	2.95 (0.27)	5.16 (0.48)
ATF2426	3.23 (0.30)	5.54 (0.51)
ATF2428	3.52 (0.33)	5.91 (0.55)
ATF2430	4.09 (0.38)	6.67 (0.62)
ATF2434	4.66 (0.43)	7.43 (0.69)
ATF2610	0.72 (0.07)	2.29 (0.21)
ATF2614	1.35 (0.13)	3.10 (0.29)
ATF2616	1.66 (0.15)	3.50 (0.33)
ATF2618	1.98 (0.18)	3.91 (0.36)
ATF26110	2.29 (0.21)	4.32 (0.40)
ATF2620	2.61 (0.24)	4.72 (0.44)
ATF2622	2.92 (0.27)	5.13 (0.48)
ATF2624	3.23 (0.30)	5.54 (0.51)
ATF2626	3.55 (0.33)	5.94 (0.55)
ATF2628	3.86 (0.36)	6.35 (0.59)
ATF2630	4.49 (0.42)	7.16 (0.67)
ATF2634	5.12 (0.48)	7.97 (0.74)
ATF2810	0.79 (0.07)	2.44 (0.23)
ATF2814	1.47 (0.14)	3.31 (0.31)
ATF2816	1.81 (0.17)	3.74 (0.35)
ATF2818	2.15 (0.20)	4.18 (0.39)
ATF28110	2.49 (0.23)	4.61 (0.43)
ATF2820	2.84 (0.26)	5.05 (0.47)
ATF2822	3.18 (0.30)	5.48 (0.51)
ATF2824	3.52 (0.33)	5.91 (0.55)
ATF2826	3.86 (0.36)	6.35 (0.59)
ATF2828	4.20 (0.39)	6.78 (0.63)
ATF2830	4.89 (0.45)	7.65 (0.71)
ATF2834	5.57 (0.52)	8.52 (0.79)
ATF21010	0.85 (0.08)	2.60 (0.24)
ATF21014	1.59 (0.15)	3.52 (0.33)
ATF21016	1.96 (0.18)	3.98 (0.37)
ATF21018	2.33 (0.22)	4.44 (0.41)

• Dimensions in parentheses are in square meters.

continued on next page

Venting Transom Window Opening and Area Specifications (continued)

Window Number	Clear Opening in Full Open Position			Glass Area Sq. Ft./ (m ²)	Vent Sq. Ft./ (m ²)	Top of Subfloor to Top of Inside Sill Stop Inches/ (mm)	Overall Window Area Sq. Ft./ (m ²)
	Clear Opening Sq. Ft./ (m ²)	Width Inches/ (mm)	Depth Inches/ (mm)				
ATV3418	1.40 (0.13)	34 5/16" (871)	5 7/8" (150)	2.85 (0.27)	1.40 (0.13)	65 1/2" (1663)	5.25 (0.49)
ATV3818	1.57 (0.15)	38 5/16" (973)	5 7/8" (150)	3.20 (0.30)	1.57 (0.15)	65 1/2" (1663)	5.78 (0.54)
ATV4018	1.73 (0.16)	42 5/16" (1075)	5 7/8" (150)	3.55 (0.33)	1.73 (0.16)	65 1/2" (1663)	6.32 (0.59)
ATV4418	1.90 (0.18)	46 5/16" (1176)	5 7/8" (150)	3.90 (0.36)	1.90 (0.18)	65 1/2" (1663)	6.85 (0.64)
ATV4818	2.06 (0.19)	50 5/16" (1278)	5 7/8" (150)	4.25 (0.40)	2.06 (0.19)	65 1/2" (1663)	7.39 (0.69)
ATV5018	2.22 (0.21)	54 5/16" (1379)	5 7/8" (150)	4.60 (0.43)	2.22 (0.21)	65 1/2" (1663)	7.92 (0.74)
ATV5418	2.39 (0.22)	58 5/16" (1481)	5 7/8" (150)	4.95 (0.46)	2.39 (0.22)	65 1/2" (1663)	8.46 (0.79)
ATV5818	2.55 (0.24)	62 5/16" (1583)	5 7/8" (150)	5.30 (0.49)	2.55 (0.24)	65 1/2" (1663)	8.99 (0.84)
ATV6018	2.71 (0.25)	66 5/16" (1684)	5 7/8" (150)	5.65 (0.53)	2.71 (0.25)	65 1/2" (1663)	9.53 (0.88)
ATV18110	0.59 (0.05)	14 5/16" (363)	5 7/8" (150)	1.28 (0.12)	0.59 (0.05)	63 1/2" (1612)	2.84 (0.26)
ATV20110	0.75 (0.07)	18 5/16" (465)	5 7/8" (150)	1.68 (0.16)	0.75 (0.07)	63 1/2" (1612)	3.43 (0.32)
ATV24110	0.91 (0.08)	22 5/16" (567)	5 7/8" (150)	2.09 (0.19)	0.91 (0.08)	63 1/2" (1612)	4.02 (0.37)
ATV26110	0.99 (0.09)	24 5/16" (617)	5 7/8" (150)	2.29 (0.21)	0.99 (0.09)	63 1/2" (1612)	4.32 (0.40)
ATV28110	1.08 (0.10)	26 5/16" (668)	5 7/8" (150)	2.49 (0.23)	1.08 (0.10)	63 1/2" (1612)	4.61 (0.43)
ATV210110	1.16 (0.11)	28 5/16" (719)	5 7/8" (150)	2.70 (0.25)	1.16 (0.11)	63 1/2" (1612)	4.91 (0.46)
ATV30110	1.24 (0.12)	30 5/16" (770)	5 7/8" (150)	2.90 (0.27)	1.24 (0.12)	63 1/2" (1612)	5.20 (0.48)
ATV32110	1.32 (0.12)	32 5/16" (821)	5 7/8" (150)	3.10 (0.29)	1.32 (0.12)	63 1/2" (1612)	5.50 (0.51)
ATV34110	1.40 (0.13)	34 5/16" (871)	5 7/8" (150)	3.31 (0.31)	1.40 (0.13)	63 1/2" (1612)	5.79 (0.54)
ATV38110	1.57 (0.15)	38 5/16" (973)	5 7/8" (150)	3.71 (0.34)	1.57 (0.15)	63 1/2" (1612)	6.38 (0.59)
ATV40110	1.73 (0.16)	42 5/16" (1075)	5 7/8" (150)	4.12 (0.38)	1.73 (0.16)	63 1/2" (1612)	6.97 (0.65)
ATV44110	1.90 (0.18)	46 5/16" (1176)	5 7/8" (150)	4.55 (0.42)	1.90 (0.18)	63 1/2" (1612)	7.56 (0.70)
ATV48110	2.06 (0.19)	50 5/16" (1278)	5 7/8" (150)	4.93 (0.46)	2.06 (0.19)	63 1/2" (1612)	8.15 (0.76)
ATV50110	2.22 (0.21)	54 5/16" (1379)	5 7/8" (150)	5.33 (0.50)	2.22 (0.21)	63 1/2" (1612)	8.74 (0.81)
ATV54110	2.39 (0.22)	58 5/16" (1481)	5 7/8" (150)	5.74 (0.53)	2.39 (0.22)	63 1/2" (1612)	9.33 (0.87)
ATV58110	2.55 (0.24)	62 5/16" (1583)	5 7/8" (150)	6.14 (0.57)	2.55 (0.24)	63 1/2" (1612)	9.92 (0.92)
ATV60110	2.71 (0.25)	66 5/16" (1684)	5 7/8" (150)	6.55 (0.61)	2.71 (0.25)	63 1/2" (1612)	10.51 (0.98)
ATV1820	0.59 (0.05)	14 5/16" (363)	5 7/8" (150)	1.45 (0.13)	0.59 (0.05)	61 1/2" (1561)	3.11 (0.29)
ATV2020	0.75 (0.07)	18 5/16" (465)	5 7/8" (150)	1.91 (0.18)	0.75 (0.07)	61 1/2" (1561)	3.75 (0.35)
ATV2420	0.91 (0.08)	22 5/16" (567)	5 7/8" (150)	2.38 (0.22)	0.91 (0.08)	61 1/2" (1561)	4.40 (0.41)
ATV2620	0.99 (0.09)	24 5/16" (617)	5 7/8" (150)	2.61 (0.24)	0.99 (0.09)	61 1/2" (1561)	4.72 (0.44)
ATV2820	1.08 (0.10)	26 5/16" (668)	5 7/8" (150)	2.84 (0.26)	1.08 (0.10)	61 1/2" (1561)	5.05 (0.47)
ATV21020	1.16 (0.11)	28 5/16" (719)	5 7/8" (150)	3.07 (0.28)	1.16 (0.11)	61 1/2" (1561)	5.37 (0.50)
ATV3020	1.24 (0.12)	30 5/16" (770)	5 7/8" (150)	3.30 (0.31)	1.24 (0.12)	61 1/2" (1561)	5.69 (0.53)
ATV3220	1.32 (0.12)	32 5/16" (821)	5 7/8" (150)	3.53 (0.33)	1.32 (0.12)	61 1/2" (1561)	6.01 (0.56)
ATV3420	1.40 (0.13)	34 5/16" (871)	5 7/8" (150)	3.76 (0.35)	1.40 (0.13)	61 1/2" (1561)	6.34 (0.59)
ATV3820	1.57 (0.15)	38 5/16" (973)	5 7/8" (150)	4.22 (0.39)	1.57 (0.15)	61 1/2" (1561)	6.98 (0.65)
ATV4020	1.73 (0.16)	42 5/16" (1075)	5 7/8" (150)	4.68 (0.43)	1.73 (0.16)	61 1/2" (1561)	7.63 (0.71)
ATV4420	1.90 (0.18)	46 5/16" (1176)	5 7/8" (150)	5.14 (0.48)	1.90 (0.18)	61 1/2" (1561)	8.28 (0.77)

• "Top of Subfloor to Top of Inside Sill Stop" is calculated based upon a structural header height of 6'-10 1/2" (2096).
 • Dimensions in parentheses are in millimeters or square meters.

continued on next page

TRANSOM WINDOWS

Table of Transom Window Sizes (continued)
Scale 1/8" (3) = 1'-0" (305) – 1:96

Notes on page 55 also apply to this page.

Unit Dimension	6'-3 1/4"	6'-7 1/4"	6'-11 1/4"	7'-3 1/4"	7'-7 1/4"	7'-11 1/4"
	(1911)	(2013)	(2115)	(2216)	(2318)	(2419)
Minimum Rough Opening	6'-4"	6'-8"	7'-0"	7'-4"	7'-8"	8'-0"
	(1930)	(2032)	(2133)	(2235)	(2336)	(2438)
Unobstructed Glass	68 5/8"	72 5/8"	76 5/8"	80 5/8"	84 5/8"	88 5/8"
	(1743)	(1845)	(1946)	(2048)	(2149)	(2251)

CUSTOM WIDTHS – fixed 15 1/4" to 95 1/4" (largest dimensions are 95 1/4" x 71 1/4" or 71 1/4" x 95 1/4")

CUSTOM HEIGHTS – fixed 11 1/4" to 95 1/4"	CUSTOM WIDTHS					
	15 1/4"	20 1/4"	25 1/4"	30 1/4"	35 1/4"	40 1/4"
11 1/4" (286)	ATF6410	ATF6810	ATF7010	ATF7410	ATF7810	ATF8010
1'-3 1/4" (387)	ATF6414	ATF6814	ATF7014	ATF7414	ATF7814	ATF8014
1'-5 1/4" (438)	ATF6416	ATF6816	ATF7016	ATF7416	ATF7816	ATF8016
1'-7 1/4" (489)	ATF6418	ATF6818	ATF7018	ATF7418	ATF7818	ATF8018
1'-9 1/4" (540)	ATF64110	ATF68110	ATF70110	ATF74110	ATF78110	ATF80110
1'-11 1/4" (591)	ATF6420	ATF6820	ATF7020	ATF7420	ATF7820	ATF8020
2'-1 1/4" (641)	ATF6422	ATF6822	ATF7022	ATF7422	ATF7822	ATF8022
2'-3 1/4" (692)	ATF6424	ATF6824	ATF7024	ATF7424	ATF7824	ATF8024
2'-5 1/4" (743)	ATF6426	ATF6826	ATF7026	ATF7426	ATF7826	ATF8026
2'-7 1/4" (794)	ATF6428	ATF6828	ATF7028	ATF7428	ATF7828	ATF8028
2'-11 1/4" (895)	ATF6430	ATF6830	ATF7030	ATF7430	ATF7830	ATF8030
3'-3 1/4" (997)	ATF6434	ATF6834	ATF734	ATF7434	ATF7834	ATF8034

Fixed Transom Window Area Specifications

Window Number	Glass Area Sq. Ft./ (m ²)	Overall Window Area Sq. Ft./ (m ²)
ATF210110	2.70 (0.25)	4.91 (0.46)
ATF21020	3.07 (0.28)	5.37 (0.50)
ATF21022	3.44 (0.32)	5.83 (0.54)
ATF21024	3.81 (0.35)	6.29 (0.58)
ATF21026	4.17 (0.39)	6.75 (0.63)
ATF21028	4.54 (0.42)	7.22 (0.67)
ATF21030	5.28 (0.49)	8.14 (0.76)
ATF21034	6.02 (0.56)	9.06 (0.84)
ATF3010	0.91 (0.08)	2.75 (0.26)
ATF3014	1.71 (0.16)	3.73 (0.35)
ATF3016	2.11 (0.20)	4.22 (0.39)

*Dimensions in parentheses are in square meters.

Venting Transom Window Opening and Area Specifications

Window Number	Clear Opening in Full Open Position			Glass Area Sq. Ft./ (m ²)	Vent Sq. Ft./ (m ²)	Top of Subfloor to Top of Inside Sill Stop Inches/ (mm)	Overall Window Area Sq. Ft./ (m ²)
	Clear Opening Sq. Ft./ (m ²)	Width Inches/ (mm)	Depth Inches/ (mm)				
ATV4820	2.06 (0.19)	50 5/16" (1278)	5 7/8" (150)	5.60 (0.52)	2.06 (0.19)	61 1/2" (1561)	8.92 (0.83)
ATV5020	2.22 (0.21)	54 5/16" (1379)	5 7/8" (150)	6.06 (0.56)	2.22 (0.21)	61 1/2" (1561)	9.57 (0.89)
ATV5420	2.39 (0.22)	58 5/16" (1481)	5 7/8" (150)	6.53 (0.61)	2.39 (0.22)	61 1/2" (1561)	10.21 (0.62)
ATV5820	2.55 (0.25)	62 5/16" (1538)	5 7/8" (150)	6.99 (0.65)	2.55 (0.25)	61 1/2" (1561)	10.86 (0.66)
ATV6020	2.71 (0.26)	66 5/16" (1684)	5 7/8" (150)	7.45 (0.69)	2.71 (0.26)	61 1/2" (1561)	11.50 (0.70)
ATV1822	0.59 (0.05)	14 5/16" (363)	5 7/8" (150)	1.63 (0.15)	0.59 (0.05)	59 1/2" (1510)	3.38 (0.31)
ATV2022	0.75 (0.07)	18 5/16" (465)	5 7/8" (150)	2.14 (0.20)	0.75 (0.07)	59 1/2" (1510)	4.08 (0.38)
ATV2422	0.91 (0.08)	22 5/16" (567)	5 7/8" (150)	2.66 (0.25)	0.91 (0.08)	59 1/2" (1510)	4.78 (0.44)
ATV2622	0.99 (0.09)	24 5/16" (617)	5 7/8" (150)	2.92 (0.27)	0.99 (0.09)	59 1/2" (1510)	5.13 (0.48)
ATV2822	1.08 (0.10)	26 5/16" (668)	5 7/8" (150)	3.18 (0.30)	1.08 (0.10)	59 1/2" (1510)	5.48 (0.51)
ATV21022	1.16 (0.11)	28 5/16" (719)	5 7/8" (150)	3.44 (0.32)	1.16 (0.11)	59 1/2" (1510)	5.83 (0.54)
ATV3022	1.24 (0.12)	30 5/16" (770)	5 7/8" (150)	3.69 (0.34)	1.24 (0.12)	59 1/2" (1510)	6.18 (0.57)
ATV3222	1.32 (0.12)	32 5/16" (821)	5 7/8" (150)	3.95 (0.37)	1.32 (0.12)	59 1/2" (1510)	6.53 (0.61)

*Top of Subfloor to Top of Inside Sill Stop" is calculated based upon a structural header height of 6'-10 1/2" (2096).
*Dimensions in parentheses are in millimeters or square meters.

continued on next page

continued on next page

Fixed Transom Window Area Specifications *(continued)*

Window Number	Glass Area Sq. Ft./ (m ²)	Overall Window Area Sq. Ft./ (m ²)
ATF3018	2.50 (0.23)	4.71 (0.44)
ATF30110	2.90 (0.27)	5.20 (0.48)
ATF3020	3.30 (0.31)	5.69 (0.53)
ATF3022	3.69 (0.34)	6.18 (0.57)
ATF3024	4.09 (0.38)	6.67 (0.62)
ATF3026	4.49 (0.42)	7.16 (0.67)
ATF3028	4.89 (0.45)	7.65 (0.71)
ATF3030	5.68 (0.53)	8.63 (0.80)
ATF3034	6.47 (0.60)	9.61 (0.89)
ATF3210	0.98 (0.09)	2.91 (0.27)
ATF3214	1.83 (0.17)	3.94 (0.37)
ATF3216	2.25 (0.21)	4.46 (0.41)
ATF3218	2.68 (0.25)	4.98 (0.46)
ATF32110	3.10 (0.29)	5.50 (0.51)
ATF3220	3.53 (0.33)	6.01 (0.56)
ATF3222	3.95 (0.37)	6.53 (0.61)
ATF3224	4.38 (0.41)	7.05 (0.65)
ATF3226	4.80 (0.45)	7.57 (0.70)
ATF3228	5.23 (0.49)	8.08 (0.75)
ATF3230	6.08 (0.56)	9.12 (0.85)
ATF3234	6.93 (0.64)	10.15 (0.94)
ATF3410	1.04 (0.10)	3.07 (0.28)
ATF3414	1.95 (0.18)	4.16 (0.39)
ATF3416	2.40 (0.22)	4.70 (0.44)
ATF3418	2.85 (0.26)	5.25 (0.49)
ATF34110	3.31 (0.31)	5.79 (0.54)
ATF3420	3.76 (0.35)	6.34 (0.59)
ATF3422	4.21 (0.39)	6.88 (0.64)
ATF3424	4.66 (0.43)	7.43 (0.69)
ATF3426	5.12 (0.48)	7.97 (0.74)
ATF3428	5.57 (0.52)	8.52 (0.79)
ATF3430	6.47 (0.60)	9.61 (0.89)
ATF3434	7.38 (0.69)	10.70 (0.99)
ATF3810	1.17 (0.11)	3.38 (0.31)
ATF3814	2.19 (0.20)	4.58 (0.43)
ATF3816	2.69 (0.25)	5.18 (0.48)
ATF3818	3.20 (0.30)	5.78 (0.54)
ATF38110	3.71 (0.34)	6.38 (0.59)
ATF3820	4.22 (0.39)	6.98 (0.65)
ATF3822	4.73 (0.44)	7.58 (0.70)
ATF3824	5.24 (0.49)	8.18 (0.76)
ATF3826	5.74 (0.53)	8.79 (0.82)
ATF3828	6.25 (0.58)	9.39 (0.87)
ATF3830	7.27 (0.68)	10.59 (0.98)
ATF3834	8.29 (0.77)	11.79 (1.10)
ATF4010	1.30 (0.12)	3.69 (0.34)
ATF4014	2.42 (0.23)	5.00 (0.46)
ATF4016	2.99 (0.28)	5.66 (0.53)
ATF4018	3.55 (0.33)	6.32 (0.59)
ATF40110	4.12 (0.38)	6.97 (0.65)
ATF4020	4.68 (0.43)	7.63 (0.71)
ATF4022	5.24 (0.49)	8.29 (0.77)
ATF4024	5.81 (0.54)	8.94 (0.83)
ATF4026	6.37 (0.59)	9.60 (0.89)
ATF4028	6.94 (0.64)	10.25 (0.95)
ATF4030	8.06 (0.75)	11.57 (1.07)
ATF4034	9.19 (0.85)	12.88 (1.20)
ATF4410	1.42 (0.13)	4.00 (0.37)

* Dimensions in parentheses are in square meters.

continued on next page

Venting Transom Window Opening and Area Specifications *(continued)*

Window Number	Clear Opening in Full Open Position		Glass Area Sq. Ft./ (m ²)	Vent Sq. Ft./ (m ²)	Top of Subfloor to Top of Inside Sill Stop Inches/ (mm)	Overall Window Area Sq. Ft./ (m ²)
	Clear Opening Sq. Ft./ (m ²)	Width Inches/ (mm) Depth Inches/ (mm)				
ATV3422	1.40 (0.13)	34 5/16" (871) 5 7/8" (150)	4.21 (0.39)	1.40 (0.13)	59 1/2" (1510)	6.88 (0.64)
ATV3822	1.57 (0.15)	38 5/16" (973) 5 7/8" (150)	4.73 (0.44)	1.57 (0.15)	59 1/2" (1510)	7.58 (0.70)
ATV4022	1.73 (0.16)	42 5/16" (1075) 5 7/8" (150)	5.24 (0.49)	1.73 (0.16)	59 1/2" (1510)	8.29 (0.77)
ATV4422	1.90 (0.18)	46 5/16" (1176) 5 7/8" (150)	5.76 (0.54)	1.90 (0.18)	59 1/2" (1510)	8.99 (0.83)
ATV4822	2.06 (0.19)	50 5/16" (1278) 5 7/8" (150)	6.28 (0.58)	2.06 (0.19)	59 1/2" (1510)	9.69 (0.90)
ATV5022	2.22 (0.21)	54 5/16" (1379) 5 7/8" (150)	6.79 (0.63)	2.22 (0.21)	59 1/2" (1510)	10.39 (0.97)
ATV5422	2.39 (0.22)	58 5/16" (1481) 5 7/8" (150)	7.31 (0.68)	2.39 (0.22)	59 1/2" (1510)	11.09 (1.03)
ATV5822	2.55 (0.24)	62 5/16" (1538) 5 7/8" (150)	7.83 (0.73)	2.55 (0.24)	59 1/2" (1510)	11.79 (1.10)
ATV6022	2.71 (0.25)	66 5/16" (1684) 5 7/8" (150)	8.34 (0.78)	2.71 (0.25)	59 1/2" (1510)	12.49 (1.16)
ATV1824	0.59 (0.05)	14 5/16" (363) 5 7/8" (150)	1.80 (0.17)	0.59 (0.05)	57 1/2" (1460)	3.64 (0.34)
ATV2024	0.75 (0.07)	18 5/16" (465) 5 7/8" (150)	2.38 (0.22)	0.75 (0.07)	57 1/2" (1460)	4.40 (0.41)
ATV2424	0.91 (0.08)	22 5/16" (567) 5 7/8" (150)	2.95 (0.27)	0.91 (0.08)	57 1/2" (1460)	5.16 (0.48)
ATV2624	0.99 (0.09)	24 5/16" (617) 5 7/8" (150)	3.23 (0.30)	0.99 (0.09)	57 1/2" (1460)	5.54 (0.51)
ATV2824	1.08 (0.10)	26 5/16" (668) 5 7/8" (150)	3.52 (0.33)	1.08 (0.10)	57 1/2" (1460)	5.91 (0.55)
ATV21024	1.16 (0.11)	28 5/16" (719) 5 7/8" (150)	3.81 (0.35)	1.16 (0.11)	57 1/2" (1460)	6.29 (0.58)
ATV3024	1.24 (0.12)	30 5/16" (770) 5 7/8" (150)	4.09 (0.38)	1.24 (0.12)	57 1/2" (1460)	6.67 (0.62)
ATV3224	1.32 (0.12)	32 5/16" (821) 5 7/8" (150)	4.38 (0.41)	1.32 (0.12)	57 1/2" (1460)	7.05 (0.65)
ATV3424	1.40 (0.13)	34 5/16" (871) 5 7/8" (150)	4.66 (0.43)	1.40 (0.13)	57 1/2" (1460)	7.43 (0.69)
ATV3824	1.57 (0.15)	38 5/16" (973) 5 7/8" (150)	5.24 (0.49)	1.57 (0.15)	57 1/2" (1460)	8.18 (0.76)
ATV4034	1.73 (0.16)	42 5/16" (1075) 5 7/8" (150)	5.81 (0.54)	1.73 (0.16)	57 1/2" (1460)	8.94 (0.83)
ATV4424	1.90 (0.18)	46 5/16" (1176) 5 7/8" (150)	6.38 (0.59)	1.90 (0.18)	57 1/2" (1460)	9.70 (0.90)
ATV4824	2.06 (0.19)	50 5/16" (1278) 5 7/8" (150)	6.95 (0.65)	2.06 (0.19)	57 1/2" (1460)	10.46 (0.97)
ATV5024	2.22 (0.21)	54 5/16" (1379) 5 7/8" (150)	7.53 (0.70)	2.22 (0.21)	57 1/2" (1460)	11.21 (1.04)
ATV5424	2.39 (0.22)	58 5/16" (1481) 5 7/8" (150)	8.10 (0.75)	2.39 (0.22)	57 1/2" (1460)	11.97 (1.11)
ATV5824	2.55 (0.24)	62 5/16" (1538) 5 7/8" (150)	8.67 (0.81)	2.55 (0.24)	57 1/2" (1460)	12.73 (1.18)
ATV6024	2.71 (0.25)	66 5/16" (1684) 5 7/8" (150)	9.24 (0.86)	2.71 (0.25)	57 1/2" (1460)	13.48 (1.25)
ATV1826	0.59 (0.05)	14 5/16" (363) 5 7/8" (150)	1.98 (0.18)	0.59 (0.05)	55 1/2" (1409)	3.91 (0.36)
ATV2026	0.75 (0.07)	18 5/16" (465) 5 7/8" (150)	2.61 (0.24)	0.75 (0.07)	55 1/2" (1409)	4.72 (0.44)
ATV2226	0.91 (0.08)	22 5/16" (567) 5 7/8" (150)	3.23 (0.30)	0.91 (0.08)	55 1/2" (1409)	5.54 (0.51)
ATV2426	0.99 (0.09)	24 5/16" (617) 5 7/8" (150)	3.55 (0.33)	0.99 (0.09)	55 1/2" (1409)	5.94 (0.55)
ATV2626	1.08 (0.10)	26 5/16" (668) 5 7/8" (150)	3.86 (0.36)	1.08 (0.10)	55 1/2" (1409)	6.35 (0.59)
ATV2826	1.16 (0.11)	28 5/16" (719) 5 7/8" (150)	4.18 (0.39)	1.16 (0.11)	55 1/2" (1409)	6.75 (0.63)
ATV3026	1.24 (0.12)	30 5/16" (770) 5 7/8" (150)	4.49 (0.42)	1.24 (0.12)	55 1/2" (1409)	7.16 (0.67)
ATV3226	1.32 (0.12)	32 5/16" (821) 5 7/8" (150)	4.80 (0.45)	1.32 (0.12)	55 1/2" (1409)	7.57 (0.70)
ATV3426	1.40 (0.13)	34 5/16" (871) 5 7/8" (150)	5.12 (0.48)	1.40 (0.13)	55 1/2" (1409)	7.97 (0.74)
ATV3826	1.57 (0.15)	38 5/16" (973) 5 7/8" (150)	5.74 (0.53)	1.57 (0.15)	55 1/2" (1409)	8.79 (0.82)
ATV4026	1.73 (0.16)	42 5/16" (1075) 5 7/8" (150)	6.37 (0.59)	1.73 (0.16)	55 1/2" (1409)	9.60 (0.89)
ATV4426	1.90 (0.18)	46 5/16" (1176) 5 7/8" (150)	7.00 (0.65)	1.90 (0.18)	55 1/2" (1409)	10.41 (0.97)
ATV4826	2.06 (0.19)	50 5/16" (1278) 5 7/8" (150)	7.63 (0.71)	2.06 (0.19)	55 1/2" (1409)	11.22 (1.04)
ATV5026	2.22 (0.21)	54 5/16" (1379) 5 7/8" (150)	8.26 (0.77)	2.22 (0.21)	55 1/2" (1409)	12.04 (1.12)
ATV5426	2.39 (0.22)	58 5/16" (1481) 5 7/8" (150)	8.88 (0.83)	2.39 (0.22)	55 1/2" (1409)	12.85 (1.19)
ATV5826	2.55 (0.24)	62 5/16" (1538) 5 7/8" (150)	9.55 (0.89)	2.55 (0.24)	55 1/2" (1409)	13.66 (1.27)
ATV6026	2.71 (0.25)	66 5/16" (1684) 5 7/8" (150)	10.14 (0.94)	2.71 (0.25)	55 1/2" (1409)	14.47 (1.34)
ATV1828	0.59 (0.05)	14 5/16" (363) 5 7/8" (150)	2.15 (0.20)	0.59 (0.05)	53 1/2" (1358)	4.18 (0.39)
ATV2028	0.75 (0.07)	18 5/16" (465) 5 7/8" (150)	2.84 (0.26)	0.75 (0.07)	53 1/2" (1358)	5.05 (0.47)
ATV2428	0.91 (0.08)	22 5/16" (567) 5 7/8" (150)	3.52 (0.33)	0.91 (0.08)	53 1/2" (1358)	5.91 (0.55)
ATV2628	0.99 (0.09)	24 5/16" (617) 5 7/8" (150)	3.86 (0.36)	0.99 (0.09)	53 1/2" (1358)	6.35 (0.59)
ATV2828	1.08 (0.10)	26 5/16" (668) 5 7/8" (150)	4.20 (0.39)	1.08 (0.10)	53 1/2" (1358)	6.78 (0.63)
ATV21028	1.16 (0.11)	28 5/16" (719) 5 7/8" (150)	4.54 (0.42)	1.16 (0.11)	53 1/2" (1358)	7.22 (0.67)
ATV3028	1.24 (0.12)	30 5/16" (770) 5 7/8" (150)	4.89 (0.45)	1.24 (0.12)	53 1/2" (1358)	7.56 (0.70)
ATV3228	1.32 (0.12)	32 5/16" (821) 5 7/8" (150)	5.23 (0.49)	1.32 (0.12)	53 1/2" (1358)	8.08 (0.75)
ATV3428	1.40 (0.13)	34 5/16" (871) 5 7/8" (150)	5.57 (0.52)	1.40 (0.13)	53 1/2" (1358)	8.52 (0.79)
ATV3828	1.57 (0.15)	38 5/16" (973) 5 7/8" (150)	6.25 (0.58)	1.57 (0.15)	53 1/2" (1358)	9.39 (0.87)
ATV4028	1.73 (0.16)	42 5/16" (1075) 5 7/8" (150)	6.94 (0.64)	1.73 (0.16)	53 1/2" (1358)	10.25 (0.95)
ATV4428	1.90 (0.18)	46 5/16" (1176) 5 7/8" (150)	7.62 (0.71)	1.90 (0.18)	53 1/2" (1358)	11.12 (1.03)
ATV4828	2.06 (0.19)	50 5/16" (1278) 5 7/8" (150)	8.30 (0.77)	2.06 (0.19)	53 1/2" (1358)	11.99 (1.11)
ATV5028	2.22 (0.21)	54 5/16" (1379) 5 7/8" (150)	8.99 (0.83)	2.22 (0.21)	53 1/2" (1358)	12.86 (1.19)
ATV5428	2.39 (0.22)	58 5/16" (1481) 5 7/8" (150)	9.67 (0.90)	2.39 (0.22)	53 1/2" (1358)	13.73 (1.28)
ATV5828	2.55 (0.24)	62 5/16" (1538) 5 7/8" (150)	10.35 (0.96)	2.55 (0.24)	53 1/2" (1358)	14.59 (1.36)
ATV6028	2.71 (0.25)	66 5/16" (1684) 5 7/8" (150)	11.04 (1.03)	2.71 (0.25)	53 1/2" (1358)	15.46 (1.44)

**Top of Subfloor to Top of Inside Sill Stop" is calculated based upon a structural header height of 6'-10 1/2" (2096).

* Dimensions in parentheses are in millimeters or square meters.

TRANSOM WINDOWS

Fixed Transom Window Area Specifications *(continued)*



Window Number	Glass Area Sq. Ft./ (m ²)	Overall Window Area Sq. Ft./ (m ²)
ATF4414	2.66 (0.25)	5.43 (0.50)
ATF4416	3.28 (0.30)	6.14 (0.57)
ATF4418	3.90 (0.36)	6.85 (0.64)
ATF44110	4.52 (0.42)	7.56 (0.70)
ATF4420	5.14 (0.48)	8.27 (0.77)
ATF4422	5.76 (0.54)	8.99 (0.83)
ATF4424	6.38 (0.59)	9.70 (0.90)
ATF4426	7.00 (0.65)	10.41 (0.97)
ATF4428	7.62 (0.71)	11.12 (1.03)
ATF4430	8.24 (0.77)	11.83 (1.09)
ATF4434	10.10 (0.94)	13.97 (1.30)
ATF4810	1.55 (0.14)	4.32 (0.40)
ATF4814	2.90 (0.27)	5.85 (0.54)
ATF4816	3.58 (0.33)	6.62 (0.61)
ATF4818	4.25 (0.40)	7.39 (0.69)
ATF48110	4.93 (0.46)	8.15 (0.76)
ATF4820	5.60 (0.52)	8.92 (0.83)
ATF4822	6.28 (0.58)	9.69 (0.90)
ATF4824	6.95 (0.65)	10.46 (0.97)
ATF4826	7.63 (0.71)	11.22 (1.04)
ATF4828	8.30 (0.77)	11.99 (1.11)
ATF4830	9.65 (0.90)	13.52 (1.26)
ATF4834	11.00 (1.02)	15.06 (1.40)
ATF5010	1.68 (0.16)	4.63 (0.43)
ATF5014	3.14 (0.29)	6.27 (0.58)
ATF5016	3.87 (0.36)	7.10 (0.66)
ATF5018	4.60 (0.43)	7.92 (0.74)
ATF50110	5.33 (0.50)	8.74 (0.81)
ATF5020	6.06 (0.56)	9.57 (0.89)
ATF5022	6.79 (0.63)	10.39 (0.97)
ATF5024	7.52 (0.70)	11.21 (1.04)
ATF5026	8.26 (0.77)	12.04 (1.12)
ATF5028	8.99 (0.83)	12.86 (1.19)
ATF5030	10.45 (0.97)	14.50 (1.35)
ATF5034	11.91 (1.11)	16.15 (1.50)
ATF5410	1.81 (0.17)	4.94 (0.46)
ATF5414	3.38 (0.31)	6.70 (0.62)
ATF5416	4.17 (0.39)	7.58 (0.70)
ATF5418	4.95 (0.46)	8.46 (0.79)
ATF54110	5.74 (0.53)	9.33 (0.87)
ATF5420	6.52 (0.61)	10.21 (0.95)
ATF5422	7.31 (0.68)	11.09 (1.03)
ATF5424	8.10 (0.75)	11.97 (1.11)
ATF5426	8.88 (0.83)	12.85 (1.19)
ATF5428	9.67 (0.90)	13.73 (1.28)
ATF5430	11.24 (1.04)	15.48 (1.44)
ATF5434	12.81 (1.19)	17.24 (1.60)
ATF5810	1.94 (0.18)	5.25 (0.49)

Window Number	Glass Area Sq. Ft./ (m ²)	Overall Window Area Sq. Ft./ (m ²)
ATF5814	3.62 (0.34)	7.12 (0.66)
ATF5816	4.46 (0.41)	8.06 (0.75)
ATF5818	5.30 (0.49)	8.99 (0.84)
ATF58110	6.14 (0.57)	9.92 (0.92)
ATF5820	6.99 (0.65)	10.86 (1.01)
ATF5822	7.83 (0.73)	11.79 (1.10)
ATF5824	8.67 (0.81)	12.73 (1.18)
ATF5826	9.51 (0.88)	13.66 (1.27)
ATF5828	10.35 (0.96)	14.59 (1.36)
ATF5830	12.04 (1.12)	16.46 (1.53)
ATF5834	13.72 (1.27)	18.33 (1.70)
ATF6010	2.06 (0.19)	5.57 (0.52)
ATF6014	3.86 (0.36)	7.55 (0.70)
ATF6016	4.76 (0.44)	8.54 (0.79)
ATF6018	5.65 (0.53)	9.52 (0.88)
ATF60110	6.55 (0.61)	10.51 (0.98)
ATF6020	7.45 (0.69)	11.50 (1.07)
ATF6022	8.34 (0.78)	12.49 (1.16)
ATF6024	9.24 (0.86)	13.48 (1.25)
ATF6026	10.14 (0.94)	14.47 (1.34)
ATF6028	11.04 (1.03)	15.46 (1.44)
ATF6030	12.83 (1.19)	17.44 (1.62)
ATF6034	14.62 (1.36)	19.42 (1.80)
ATF6410	2.19 (0.20)	5.88 (0.55)
ATF6414	4.10 (0.38)	7.97 (0.74)
ATF6416	5.05 (0.47)	9.01 (0.84)
ATF6418	6.00 (0.56)	10.06 (0.93)
ATF64110	6.96 (0.65)	11.10 (1.03)
ATF6420	7.91 (0.73)	12.15 (1.13)
ATF6422	8.86 (0.82)	13.19 (1.23)
ATF6424	9.81 (0.91)	14.24 (1.32)
ATF6426	10.77 (1.00)	15.29 (1.42)
ATF6428	11.72 (1.09)	16.33 (1.52)
ATF6430	13.62 (1.27)	18.42 (1.71)
ATF6434	15.53 (1.44)	20.51 (1.91)
ATF6810	2.32 (0.22)	6.19 (0.58)
ATF6814	4.34 (0.40)	8.39 (0.78)
ATF6816	5.34 (0.50)	9.49 (0.88)
ATF6818	6.35 (0.59)	10.59 (0.98)
ATF68110	7.36 (0.68)	11.69 (1.09)
ATF6820	8.37 (0.78)	12.80 (1.19)
ATF6822	9.38 (0.87)	13.90 (1.29)
ATF6824	10.39 (0.97)	15.00 (1.39)
ATF6826	11.39 (1.06)	16.10 (1.50)
ATF6828	12.40 (1.15)	17.20 (1.60)
ATF6830	14.42 (1.34)	19.40 (1.80)
ATF6834	16.44 (1.53)	21.60 (2.01)
ATF7010	2.45 (0.23)	6.50 (0.60)

Window Number	Glass Area Sq. Ft./ (m ²)	Overall Window Area Sq. Ft./ (m ²)
ATF7014	4.57 (0.42)	8.82 (0.82)
ATF7016	5.64 (0.52)	9.97 (0.93)
ATF7018	6.70 (0.62)	11.13 (1.03)
ATF70110	7.77 (0.72)	12.29 (1.14)
ATF7020	8.83 (0.82)	13.44 (1.25)
ATF7022	9.89 (0.92)	14.60 (1.36)
ATF7024	10.96 (1.02)	15.75 (1.46)
ATF7026	12.02 (1.12)	16.91 (1.57)
ATF7028	13.09 (1.22)	18.07 (1.68)
ATF7030	15.21 (1.41)	20.38 (1.89)
ATF7034	17.34 (1.61)	22.69 (2.11)
ATF7410	2.57 (0.24)	6.82 (0.63)
ATF7414	4.81 (0.45)	9.24 (0.86)
ATF7416	5.93 (0.55)	10.45 (0.97)
ATF7418	7.05 (0.65)	11.66 (1.08)
ATF74110	8.17 (0.76)	12.88 (1.20)
ATF7420	9.29 (0.86)	14.09 (1.31)
ATF7422	10.41 (0.97)	15.03 (1.40)
ATF7424	11.53 (1.07)	16.51 (1.53)
ATF7426	12.65 (1.18)	17.72 (1.65)
ATF7428	13.77 (1.28)	18.93 (1.76)
ATF7430	16.01 (1.49)	21.36 (1.98)
ATF7434	18.25 (1.70)	23.78 (2.21)
ATF7810	2.70 (0.25)	7.13 (0.66)
ATF7814	5.05 (0.47)	9.66 (0.90)
ATF7816	6.23 (0.58)	10.93 (1.02)
ATF7818	7.40 (0.69)	12.20 (1.13)
ATF78110	8.58 (0.80)	13.47 (1.25)
ATF7820	9.75 (0.91)	14.73 (1.37)
ATF7822	10.93 (1.02)	16.00 (1.49)
ATF7824	12.10 (1.12)	17.27 (1.60)
ATF7826	13.28 (1.23)	18.54 (1.72)
ATF7828	14.45 (1.34)	19.80 (1.84)
ATF7830	16.80 (1.56)	22.34 (2.08)
ATF7834	19.15 (1.78)	24.87 (2.31)
ATF8010	2.83 (0.26)	7.44 (0.69)
ATF8014	5.29 (0.49)	10.09 (0.94)
ATF8016	6.52 (0.61)	11.41 (1.06)
ATF8018	7.75 (0.72)	12.73 (1.18)
ATF80110	8.98 (0.83)	14.06 (1.31)
ATF8020	10.21 (0.95)	15.38 (1.43)
ATF8022	11.44 (1.06)	16.70 (1.55)
ATF8024	12.67 (1.18)	18.02 (1.67)
ATF8026	13.91 (1.29)	19.35 (1.80)
ATF8028	15.14 (1.43)	20.67 (1.92)
ATF8030	17.60 (1.64)	23.32 (2.17)
ATF8034	20.06 (1.86)	26.96 (2.50)

* Dimensions in parentheses are in square meters.

Grille Patterns

	Diamond	Prairie A	Colonial
Transom			

Number of lights and overall pattern varies with window size. Patterns may not be available in all configurations or sizes. Specified equal light and custom patterns are also available.

For more grille options, see page 19 or visit andersenwindows.com/grilles.

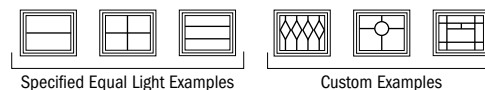

Fixed Transom Window Details

Scale 1 1/2" (38) = 1'-0" (305) – 1:8

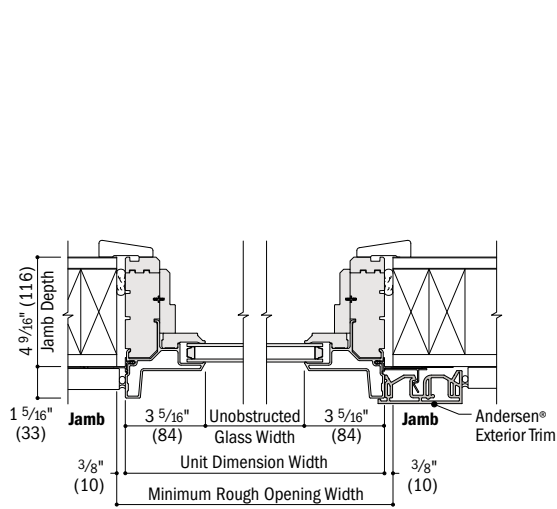

Horizontal Section

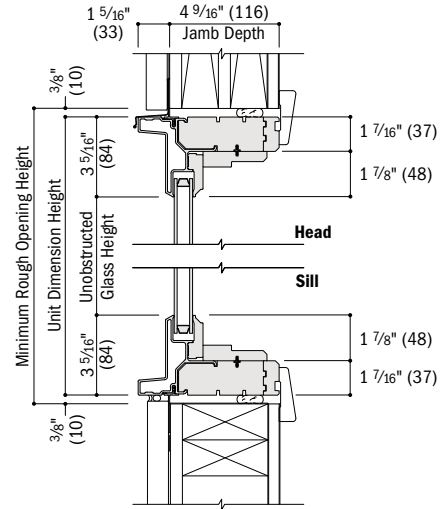

Vertical Section

Venting Transom Window Details

Scale 1 1/2" (38) = 1'-0" (305) – 1:8

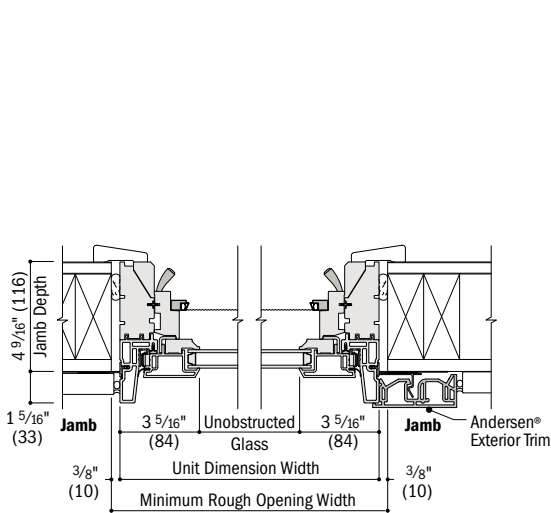

Horizontal Section

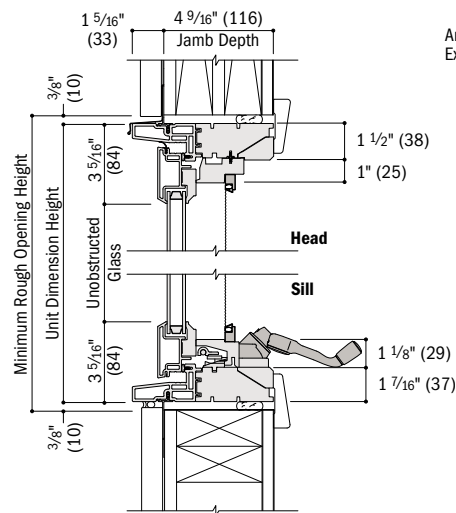

Vertical Section

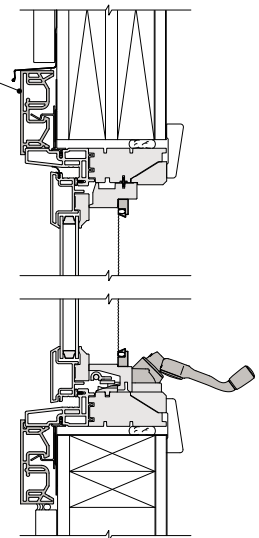

Vertical Section

A-Series Transom Windows

See pages 60-62 for joining details.

- 4 9/16" (116) base jamb depth measurement is from back side of installation flange.
- Light-colored areas are parts included with window. Dark-colored areas are additional Andersen® parts required to complete window assembly as shown.
- Dimensions in parentheses are in millimeters.
- **Minimum rough openings may need to be increased to allow for use of building wraps, flashing, sill panning, brackets, fasteners or other items. See installation information on pages 226-227.**
- Details are for illustration only and are not intended to represent product installation methods or materials. Refer to product installation instruction at andersenwindows.com.

WINDOWS

Minimum Rough Opening Calculation Examples

Single Window

2'-11 1/4" (895)	Width dimension, window 1
+ 3/8" (10)	Rough opening clearance, side 1
+ 3/8" (10)	Rough opening clearance, side 2
3'-0" (914)	Total

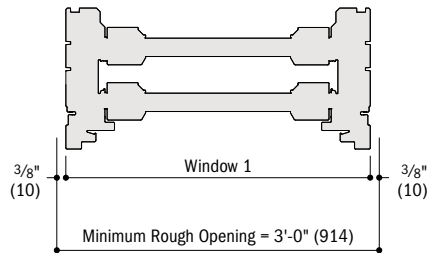

Two Vertical (ribbon) Joined Windows

2'-11 1/4" (895)	Width dimension, window 1
2'-11 1/4" (895)	Width dimension, window 2
+ 3/8" (10)	Rough opening clearance, side 1
+ 3/8" (10)	Rough opening clearance, side 2
+ 3/4" (19)	Fiberglass joining material, join 1
6'-0" (1829)	Total

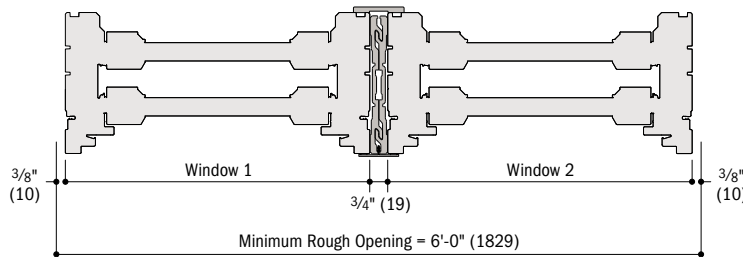

For factory-joined windows, modular sizing allows for easy calculation of minimum rough opening sizes.

Three Vertical (ribbon) Joined Windows

2'-11 1/4" (895)	Width dimension, window 1
2'-11 1/4" (895)	Width dimension, window 2
2'-11 1/4" (895)	Width dimension, window 3
+ 3/8" (10)	Rough opening clearance, side 1
+ 3/8" (10)	Rough opening clearance, side 2
+ 3/4" (19)	Fiberglass joining material, join 1
+ 3/4" (19)	Fiberglass joining material, join 2
9'-0" (2743)	Total

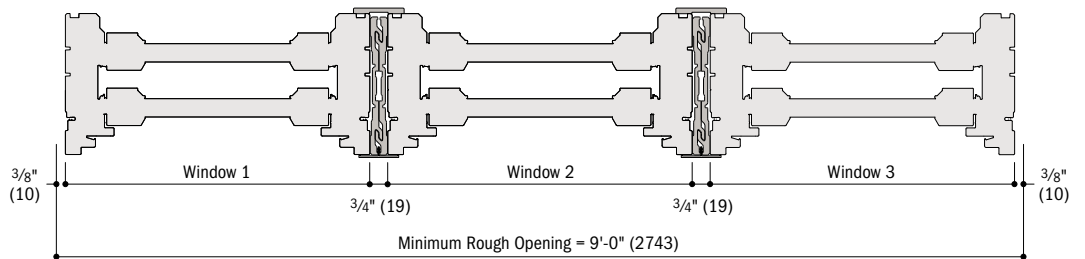

* Dimensions in parentheses are in millimeters.

* **Minimum rough openings may need to be increased to allow for use of building wraps, flashing, sill panning, brackets, fasteners or other items. See installation information on pages 226-227.**

* Details are for illustration only and are not intended to represent product installation methods or materials. Refer to product installation instructions at andersenwindows.com.

* Structural performance of any combination is only as high as the lowest structural performance of any individual product or join in the combination.

Vertical (ribbon) Joining Details

Scale 3" (76) = 1'-0" (305) – 1:4

Windows can be joined to other windows using clips or 4 9/16" (116) fiberglass joining material. See page 112 for specialty window joining details.

Overall Window Dimension Width – Sum of individual window widths plus 3/4" (19) per join.

Overall Minimum Rough Opening Width – Overall window dimension width plus 3/4" (19).

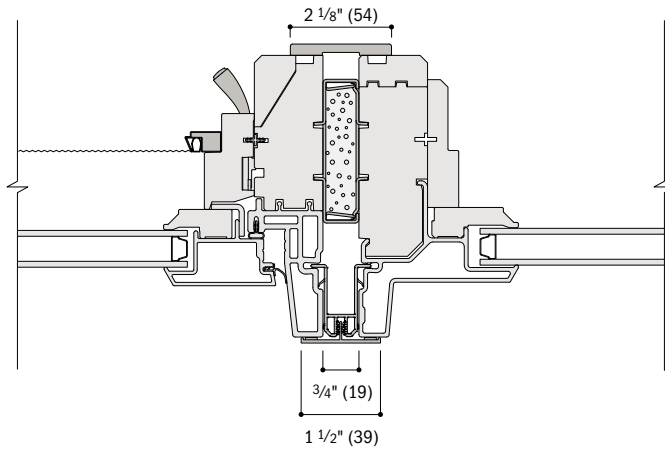

Casement to Picture
Clip

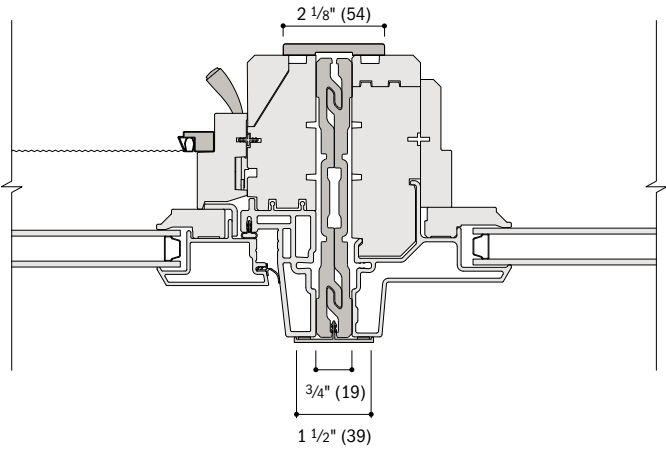

Casement to Picture
Fiberglass

Vertical (ribbon) Easy Connect Fiberglass Joining Details

Scale 1 1/2" (38) = 1'-0" (305) – 1:8

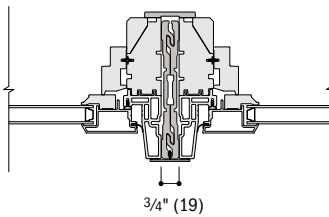

Casement to Casement
Stationary Jamb to Stationary Jamb

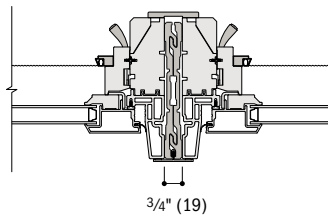

Casement to Casement
Lock Jamb to Lock Jamb

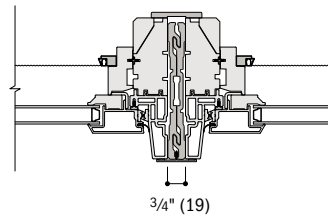

Casement to Casement
Hinge Jamb to Hinge Jamb

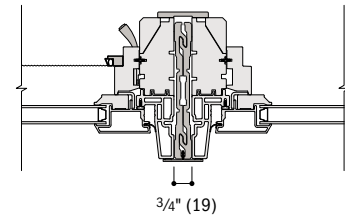

Casement to Casement
Lock Jamb to Stationary Jamb

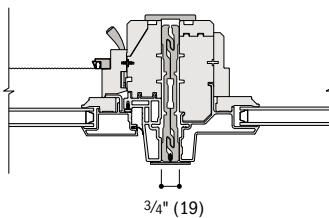

Casement to Picture
Casement Lock Jamb

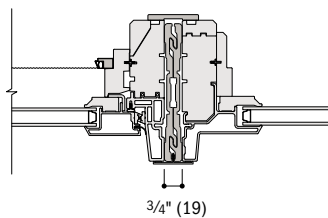

Casement to Picture
Casement Hinge Jamb

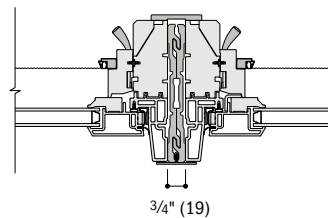

Awning to Awning

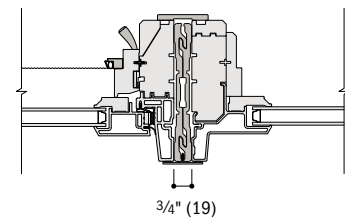

Awning to Picture

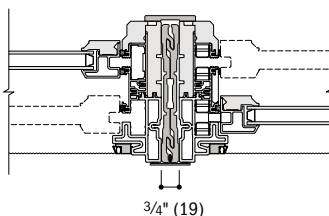

Double-Hung to Double-Hung

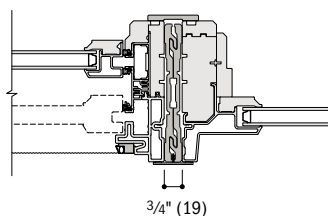

Double-Hung to Picture

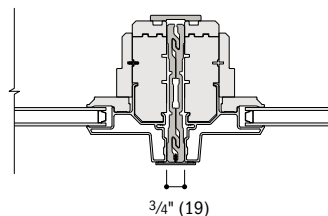

Picture to Picture

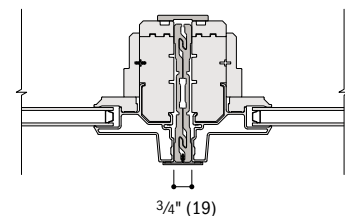

Fixed Transom to Fixed Transom

- Light-colored areas are parts included with window. Dark-colored areas are additional Andersen® parts required to complete window assembly as shown.
- Dimensions in parentheses are in millimeters.
- **Minimum rough openings may need to be increased to allow for use of building wraps, flashing, sill panning, brackets, fasteners or other items. See installation information on pages 226-227.**
- Details are for illustration only and are not intended to represent product installation methods or materials. Refer to product installation instructions at andersenwindows.com.
- Structural performance of any combination is only as high as the lowest structural performance of any individual product or join in the combination.
- Not all combinations are shown above; visit andersenwindows.com or contact your Andersen supplier for additional joining details.

WINDOWS

Horizontal (stack) Joining Details

Scale 3" (76) = 1'-0" (305) – 1:4

Windows can be joined to other windows using clips or 4 9/16" (116) fiberglass joining material. See page 112 for specialty window joining details.

Overall Window Dimension Height -

Sum of individual window heights plus 3/4" (19) per join.

Overall Minimum Rough Opening Height -

Overall window dimension height plus 3/4" (19).

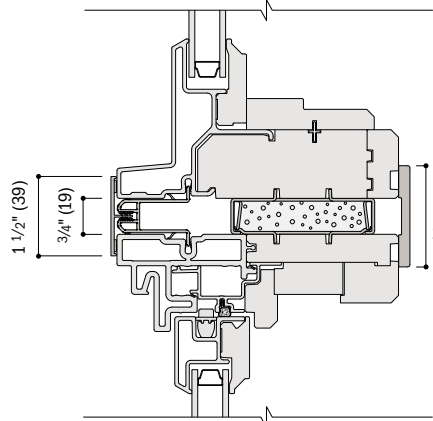

Fixed Transom Over Double-Hung

Clip

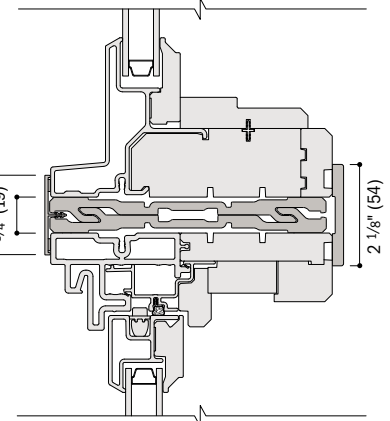

Fixed Transom Over Double-Hung

Fiberglass

Horizontal (stack) Easy Connect Fiberglass Joining Details

Scale 1 1/2" (38) = 1'-0" (305) – 1:8

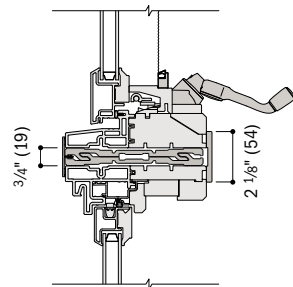

Venting Transom Over Double-Hung

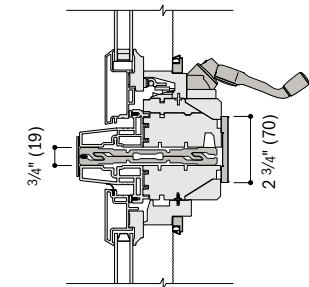

Casement/Awning Over Casement/Awning

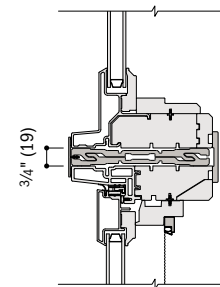

Fixed Transom Over Casement/Awning

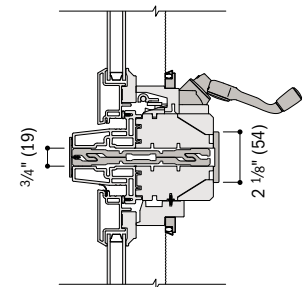

Venting Transom Over Casement/Awning

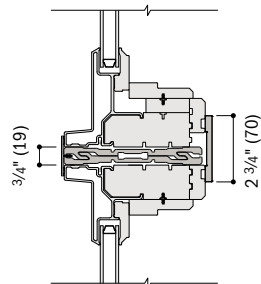

Picture Over Picture

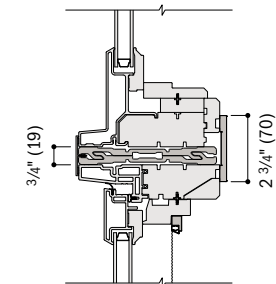

Picture Over Casement/Awning

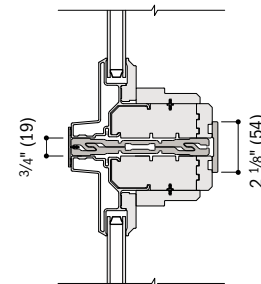

Fixed Transom Over Picture

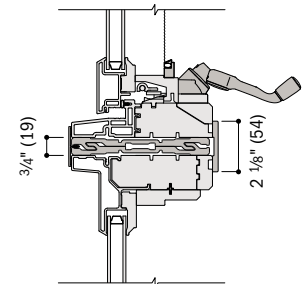

Venting Transom Over Picture

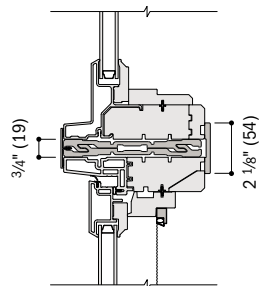

Fixed Transom Over Venting Transom

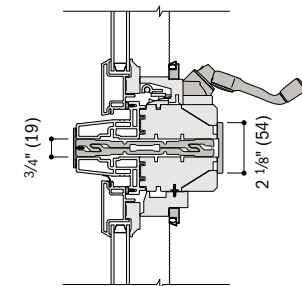

Venting Transom Over Venting Transom

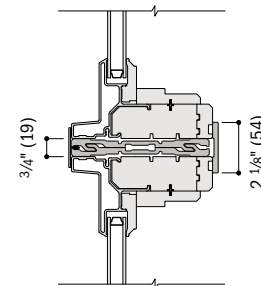

Fixed Transom Over Fixed Transom

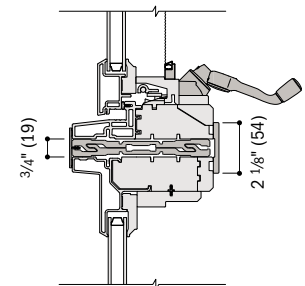

Venting Transom Over Fixed Transom

For more information on joining, refer to the combination designs section starting on page 196.

* Light-colored areas are parts included with window. Dark-colored areas are additional Andersen® parts required to complete window assembly as shown.
* Dimensions in parentheses are in millimeters.

* **Minimum rough openings may need to be increased to allow for use of building wraps, flashing, sill panning, brackets, fasteners or other items. See installation information on pages 226-227.**

* Details are for illustration only and are not intended to represent product installation methods or materials. Refer to product installation instructions at andersenwindows.com.

* Structural performance of any combination is only as high as the lowest structural performance of any individual product or join in the combination.

* Fixed transom windows (ATF) can only be joined to venting transoms windows (ATV) vertically and double-hung windows (ADH) can only be joined to double-hung windows (ADH) vertically. Not all combinations are shown above; visit andersenwindows.com or contact your Andersen supplier for additional joining details.

Custom Sizes and Specification Formulas



A-Series custom-size windows are available in 1/8" (3) increments between minimum and maximum widths and heights shown. Some restrictions apply. **For specialty windows and windows with PG upgrade, contact your Andersen supplier for custom sizing and specifications.** Clear opening dimensions for custom-sized windows are also available in iQ+; contact your Andersen supplier.

Casement Windows (venting & stationary)

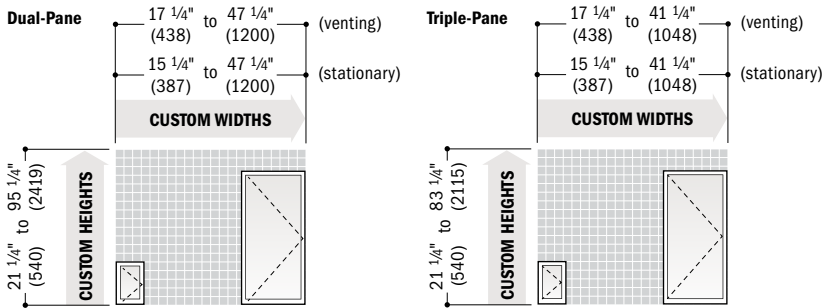

	Clear Opening Width = Clear opening width for custom-sized casement windows is based on window width and hinge type. Contact you Andersen supplier for clear opening width. Height = window height - 5.65" (144)		Minimum R.O. Width = window width + 3/4" (19) Height = window height + 3/4" (19)
	Vent Opening Width = window width - 6.54" (166) Height = window height - 5.65" (144)		

* All casement windows wider than 2'-3 1/4" (692) and taller than 3'-11 1/4" (1200) meet or exceed clear opening area of 5.7 sq. ft. or .053 m², clear opening width of 20" (508) and clear opening height of 24" (610).

Awning Windows (venting & stationary)

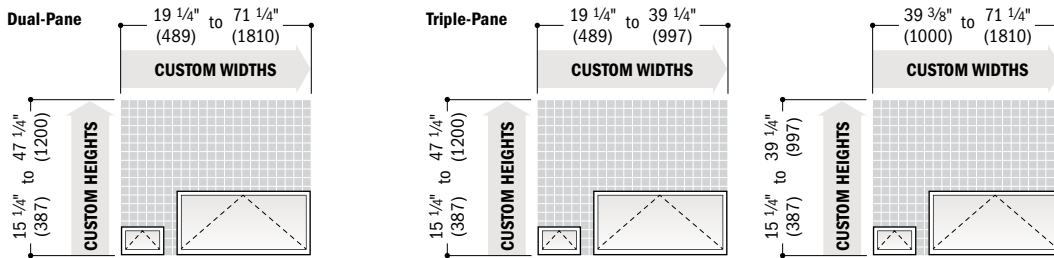

	Clear Opening Width = window width - 4.94" (125) Depth = 5.88" (149)		Minimum R.O. Width = window width + 3/4" (19) Height = window height + 3/4" (19)
	Vent Opening Width = window width - 4.94" (125) Depth = 5.88" (149)		

* Awning windows do not meet clear opening area of 5.7 sq. ft. or 0.53 m², clear opening width of 20" (508) and clear opening height of 24" (610).

* Dimensions in parentheses are in millimeters.

* **Clear Opening** formulas provide dimensions for determining area available for egress. **Vent Opening** formulas provide dimensions for determining area available for passage of air. **Minimum R.O.** (minimum rough opening) formulas provide minimum rough opening width and height dimensions. **Unobst. Glass** (unobstructed glass) formulas provide dimensions for determining area available for passage of light.





WINDOWS

Double-Hung Windows

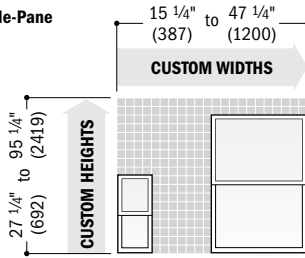
Equal Sash Ratio

Dual-Pane & Triple-Pane



Clear Opening* 	Width = window width - 4.06" (103) Height = (window height + 2) - 4.65" (118)	Minimum R.O. 	Width = window width + 3/4" (19) Height = window height + 3/4" (19)
Vent Opening* 	Width = window width - 4.06" (103) Height = (window height + 2) - 3.84" (98)	Unobst. Glass 	Width = window width - 6.65" (169) Single Sash Height = (window height - 9.65" (245)) + 2 Total Sash Height = window height - 9.65" (245)

- * Windows wider than 3'-1 1/4" (946) and taller than 4'-11 1/4" (1505) meet or exceed clear opening area of 5.7 sq. ft. or .053 m², clear opening width of 20" (508) and clear opening height of 24" (610).
- * Two locks are standard for windows with triple-pane glass or art glass on sizes wider than 1'-7 1/8" (486).
- * Two locks are standard for windows with dual-pane glass on sizes wider than 3'-3 1/4" (997).
- * Windows with triple-pane or art glass wider than 2'-11 1/4" (895) and taller than 5'-11 1/4" (1810) may have limited sash travel. Contact your Andersen supplier for clear opening and vent opening specifications.

2:3 Cottage Sash Ratio



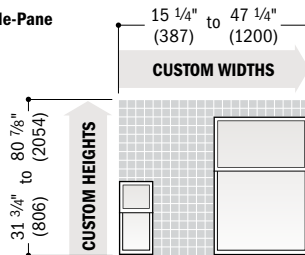



Dual-Pane & Triple-Pane

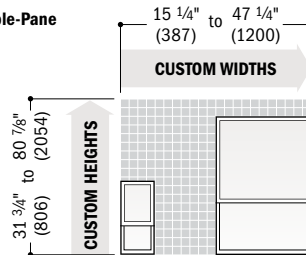

3:2 Reverse Cottage Sash Ratio

Dual-Pane & Triple-Pane



Clear Opening* 	Width = window width - 4.06" (103) Height = (window height - 4.18" (106)) x 0.4 - 2.01" (51)	Minimum R.O. 	Width = window width + 3/4" (19) Height = window height + 3/4" (19)
Vent Opening* 	2:3 Cottage Sash Ratio Width = window width - 4.06" (103) Height = (window height - 4.18" (106)) x 0.4 - 2.01" (51) + 0.8" (20)	Unobst. Glass 	2:3 Cottage Sash Ratio Width = window width - 6.65" (169) Upper Sash Height = (window height - 9.65" (245)) x 0.4 Lower Sash Height = (window height - 9.65" (245)) x 0.6 Total Sash Height = window height - 9.65" (245)
	3:2 Reverse Cottage Sash Ratio Width = window width - 4.06" (103) Height = (window height - 4.18" (106)) x 0.4 - 2.01" (51) + 2.2" (56)		3:2 Reverse Cottage Sash Ratio Width = window width - 6.65" (169) Upper Sash Height = (window height - 9.65" (245)) x 0.6 Lower Sash Height = (window height - 9.65" (245)) x 0.4 Total Sash Height = window height - 9.65" (245)

- * Two locks are standard for windows with triple-pane glass or art glass on sizes wider than 1'-7 1/8" (486).
- * Two locks are standard for windows with dual-pane glass on sizes wider than 3'-3 1/4" (997).
- * Windows with triple-pane or art glass wider than 2'-11 1/4" (895) and taller than 4'-11 1/4" (1505) may have limited sash travel. Contact your Andersen supplier for clear opening and vent opening specifications.

* Dimensions in parentheses are in millimeters.

* **Clear Opening** formulas provide dimensions for determining area available for egress. **Vent Opening** formulas provide dimensions for determining area available for passage of air. **Minimum R.O.** (minimum rough opening) formulas provide minimum rough opening width and height dimensions. **Unobst. Glass** (unobstructed glass) formulas provide dimensions for determining area available for passage of light.

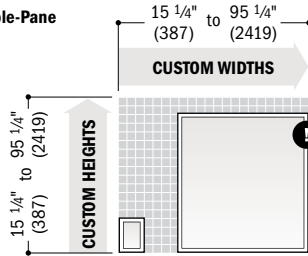
Picture Windows
Dual-Pane & Triple-Pane

Largest dimensions are
95 1/4" (2419) x 71 1/4" (1810)
or 71 1/4" (1810) x 95 1/4" (2419)

	Minimum R.O. Width = window width + 3/4" (19) Height = window height + 3/4" (19)		Unobst. Glass Width = window width - 6.65" (169) Height = window height - 7.45" (189)

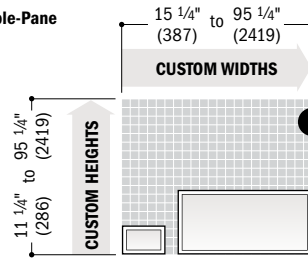
Fixed Transom Windows
Dual-Pane & Triple-Pane

Largest dimensions are
95 1/4" (2419) x 71 1/4" (1810)
or 71 1/4" (1810) x 95 1/4" (2419)

	Minimum R.O. Width = window width + 3/4" (19) Height = window height + 3/4" (19)		Unobst. Glass Width = window width - 6.65" (169) Height = window height - 6.65" (169)

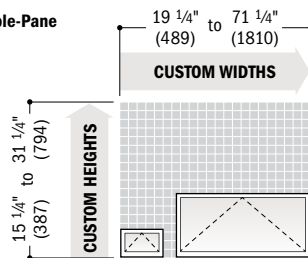
Venting Transom Windows
Dual-Pane & Triple-Pane

	Clear Opening Width = window width - 4.94" (125) Depth = 5.88" (149)		Minimum R.O. Width = window width + 3/4" (19) Height = window height + 3/4" (19)
	Vent Opening Width = window width - 4.94" (125) Depth = 5.88" (149)		

* Venting transom windows do not meet clear opening area of 5.7 sq. ft. or 0.53 m², clear opening width of 20" (508) and clear opening height of 24" (610).

* Dimensions in parentheses are in millimeters.

* **Clear Opening** formulas provide dimensions for determining area available for egress. **Vent Opening** formulas provide dimensions for determining area available for passage of air. **Minimum R.O.** (minimum rough opening) formulas provide minimum rough opening width and height dimensions. **Unobst. Glass** (unobstructed glass) formulas provide dimensions for determining area available for passage of light.

NOTES

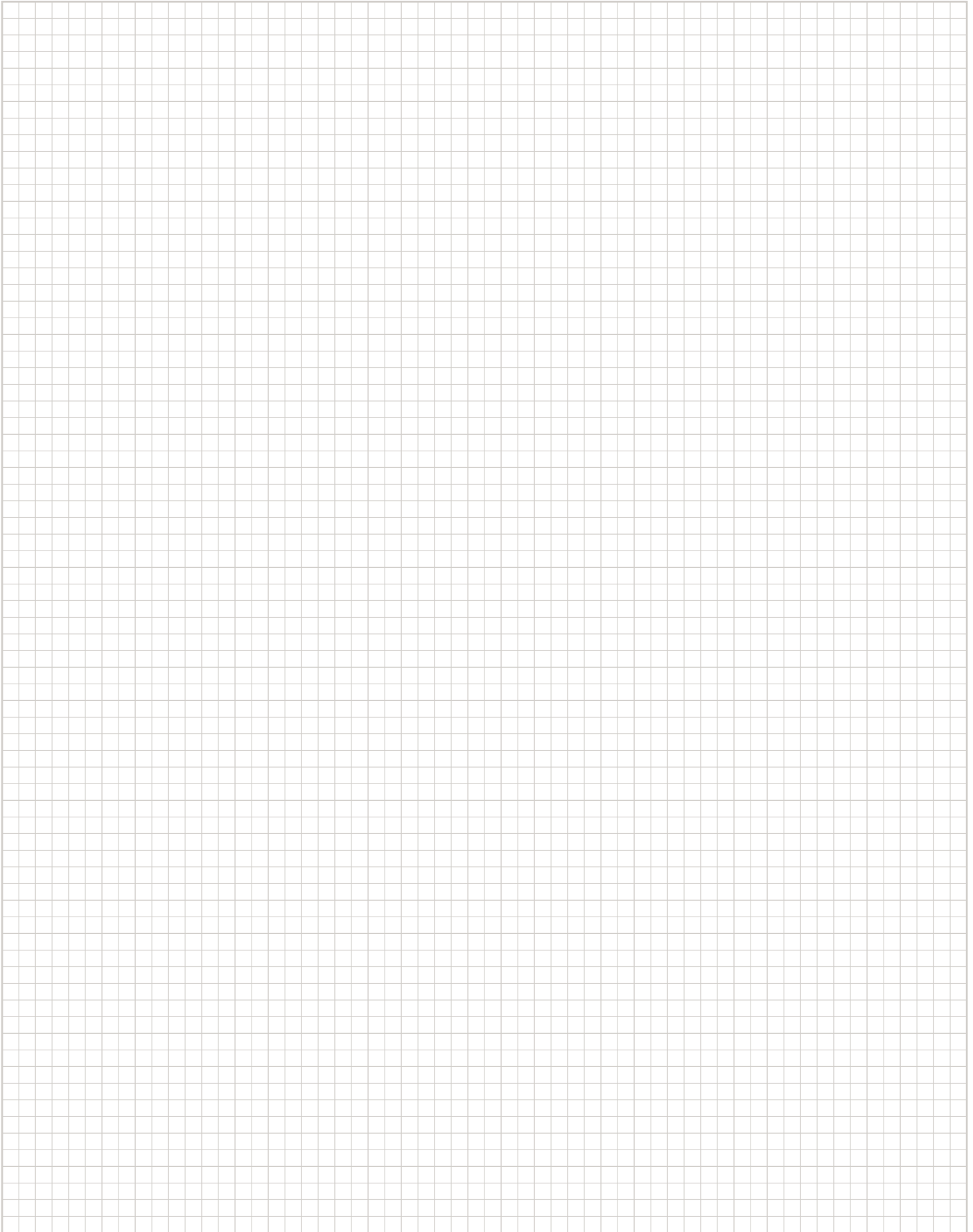

SPECIALTY WINDOWS

Half Circle, Elliptical & Quarter Circle

Tables of Sizes	70-73
Direct-Set Specifications	77
Sash-Set Specifications	78-79
Grille Patterns	73

Unequal Leg Arch

Table of Sizes	74-75
Direct-Set Specifications	77-78
Sash-Set Specifications	78
Grille Patterns	75

Octagon, Circle & Oval

Tables of Sizes	76
Direct-Set Specifications	77
Sash-Set Specifications	79
Grille Patterns	76

Trapezoid

	79
--	----

Arch

Table of Sizes	80-95
Direct-Set Specifications	84-85, 90-91
Sash-Set Specifications	94-97
Grille Patterns	105

Springline™

Table of Sizes	98-104, 106, 108
Direct-Set Specifications	105, 107
Sash-Set Specifications	108-110
Grille Patterns	105

Window Details	111
----------------------	-----

Joining Details	112
-----------------------	-----

Combination Designs	196
---------------------------	-----

Product Performance	206
---------------------------	-----

CUSTOM SIZING
in 1/8" (3) increments 

Dimensions in parentheses are in millimeters.



SPECIALTY WINDOWS

FEATURES

FRAME

A The frame is constructed with wood and protected with a heavy-duty extruded aluminum cladding. Standard cladding finish meets AAMA 2604.

An optional finish that meets the AAMA 2605 standard is also available. This construction produces a rigid frame and a low-maintenance, durable exterior with no exposed ends.

B A vinyl installation flange extends 1½" (38) around the perimeter of the unit to help properly position the unit in the opening. Installation clips are standard for increased structural anchoring to building members. Mounted around the frame perimeter, the clips rotate into position and can be bent into place against the framing members to suit all jamb conditions.

C Wood frame members are treated with a water-repellent preservative for long-lasting* protection and performance. Radii are made of laminated continuous veneers. Lineal components are solid or engineered wood with a pine core.

SASH

D Natural wood interiors are treated with a water-repellent wood preservative for long-lasting* protection and performance.

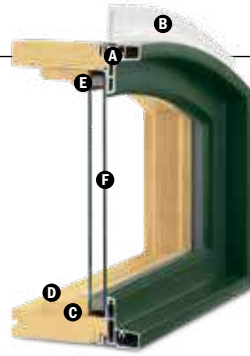

Direct-Set Arch Window

Available in direct-set or sash-set construction. Direct-set windows have glass glazed directly into the frame and maximize glass area. Sash-set windows feature a stationary sash and provide common sight lines with other A-Series venting windows. Sash are constructed with wood and protected with a heavy-duty aluminum cladding. This construction produces a rigid sash and a low-maintenance durable exterior.

Traditional architectural style:

- Classic chamfer detailing
- Look of mortise-and-tenon joinery

E Silicone glazing fillet bead combined with two-sided tape provides superior weathertightness.

F GLASS

In addition to stainless steel glass spacers, black or white glass spacers are available to allow the spacer to blend in with the unit color.

¾" (19) dual-pane glass construction provides exceptional energy performance. High-Performance dual-pane glass options include:

- Low-E4® glass
- Low-E4 HeatLock® glass
- Low-E4 SmartSun™ glass
- Low-E4 SmartSun HeatLock glass
- Low-E4 Sun glass

For even greater energy performance, 1" (25) triple-pane glass is available in these options:

- Low-E4 glass
- Low-E4 Enhanced glass
- Low-E4 Enhanced HeatLock glass
- Low-E4 SmartSun glass
- Low-E4 SmartSun Enhanced glass
- Low-E4 SmartSun Enhanced HeatLock glass

Tempered glass and other glass options are available; see your Andersen supplier.

A removable translucent film helps shield the glass from damage during delivery and construction, and simplifies finishing at the job site.

Patterned Glass

Patterned glass options are available. See page 15 for more details.

Between-the-Glass Art Glass

Available in a variety of original patterns. For details, see page 16 or visit andersenwindows.com/artglass.

PERFORMANCE OPTIONS

Performance Grade (PG) Upgrades

Performance Grade (PG) upgrades are now available for all A-Series windows in most sizes of standard non-impact windows allowing these units to achieve higher performance ratings. PG upgrade ratings are more comprehensive than Design Pressure (DP) ratings for measuring product performance. For up-to-date performance information of individual products, visit andersenwindows.com.



A-Series windows available with Stormwatch® Protection include impact-resistant glass in addition to structural upgrades for coastal areas. For a copy of the A-Series Coastal Product Guide, visit andersenwindows.com/coastal.

EXTERIORS & INTERIORS

EXTERIOR COLORS



INTERIOR WOOD SPECIES



FACTORY-FINISHED INTERIORS



All wood interiors are unfinished unless a finish is specified. Clear coat available on all wood species; all other factory finishes on pine, maple and oak. Shown above on pine. Naturally occurring variations in grain, color and texture of wood make each window one of a kind.

INTERIOR PAINT COLORS

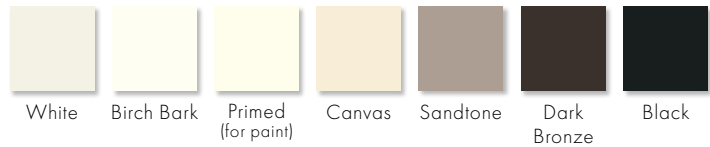

Also available in 11 exterior colors shown above; contact your Andersen supplier. Painted colors on pine or maple.

4-TONE INTERIORS

Mix and match up to four interior wood species, stains and/or colors for your window's frame, sash, grilles and extension jambs to achieve a look unique to your project.

*Visit andersenwindows.com/warranty for details.

**Actual wood species is either Sapele or Sipo, both non-endangered species grown in Africa, with color and characteristics similar to Central American mahoganies.

Printing limitations prevent exact duplication of colors. See your Andersen supplier for actual color samples.

Dimensions in parentheses are in millimeters.

ACCESSORIES Sold Separately

FRAME

Extension Jambs

Extension jambs are available in pine, maple, vertical grain Douglas fir, oak, mahogany* and cherry, precut to fit your unit. Available in 1/16" (1.5) increments up to 7 1/8" (181) and can be prefinished in six stain colors as well as all interior paint options to match the interior of the unit. This option is also available factory applied.

Interior Arch Casing

Available in Colonial or Ranch styles. Arch casings come with transition blocks or plinth blocks, depending on the product. For easy integration and consistency, casing dimensions are consistent with Wood Moulding and Millwork Producers Association specifications. Available in pine, maple, vertical grain Douglas fir, oak, mahogany* and cherry. Additional species are available.



2 1/4" (57) Colonial style. WM366



2 1/2" (64) Colonial style. WM351



3 1/2" (89) Colonial style. WM444



2 1/4" (57) Ranch style. WM324
2 1/2" (64) Ranch style. WM315

Plinth Blocks

For enhancing casing transitions. Decorated with a radial sunburst, or use the reverse side flush face.



For arch windows with 2 1/4" (57) and 2 1/2" (64) casing, use 2 7/8" (73) x 4" (102) size plinth block. For arch windows with 3 1/2" (89) casing, use 3 7/8" (98) x 5 1/4" (133) size plinth block.



For half circle, circle, elliptical and oval windows with 2 1/4" (57) and 2 1/2" (64) casing, use 2 7/8" (73) size plinth block. For half circle, circle, elliptical and oval windows with 3 1/2" (89) casing, use 3 7/8" (98) size plinth block.

GRILLES

Grilles are available in a variety of configurations and widths. See page 19 for details.

EXTERIOR TRIM

Available with Andersen exterior trim. See exterior trim section starting on page 189.

*Actual wood species is either Sapele or Sipo, both non-endangered species grown in Africa, with color and characteristics similar to Central American mahoganies.

SPECIALTY SHAPES

A-Series specialty windows are available in a variety of shapes and sizes. Profiles may vary dependent upon shape. Standard shapes include half circle, quarter circle, elliptical, circle, oval, octagon, Springline™, unequal leg arch, arch, trapezoid and rectangle. Additional shapes, shown below on the right, are available by special order.

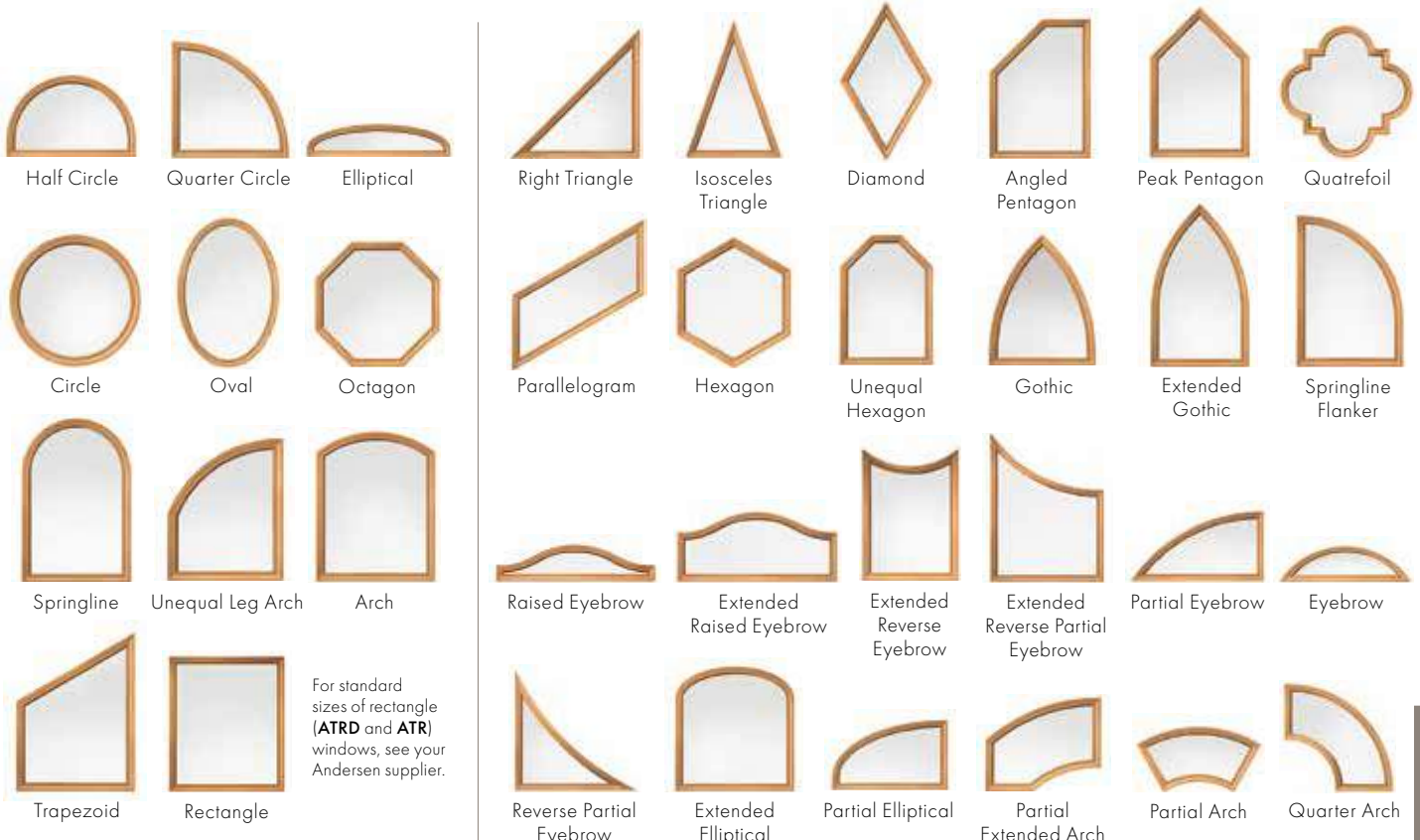

For standard sizes of rectangle (ATRD and ATR) windows, see your Andersen supplier.

Dimensions in parentheses are in millimeters.

SPECIALTY WINDOWS

Table of Direct-Set Half Circle Window Sizes

Scale 1/8" (3) = 1'-0" (305) – 1:96

Notes on the next page also apply to this page.

Window Dimension	1'-11 1/4" (591)	2'-0 1/8" (613)	2'-3 1/4" (692)	2'-5 1/4" (743)	2'-6 1/8" (765)
Minimum Rough Opening	2'-0" (609)	2'-1" (635)	2'-4" (711)	2'-6" (762)	2'-7" (787)
Unobstructed Glass	18 7/8" (478)	19 3/4" (501)	22 15/16" (582)	24 15/16" (633)	25 13/16" (656)
	11 5/8" (295) 1'-0 3/8" (314) 7 5/8" (194)	1'-0 1/16" (306) 1'-0 13/16" (325) 8 1/16" (205)	1'-1 5/8" (346) 1'-2 3/8" (365) 9 5/8" (244)	1'-2 5/8" (371) 1'-3 3/8" (391) 10 5/8" (270)	1'-3 1/16" (383) 1'-3 13/16" (402) 11 1/16" (281)
	ATCTD20	ATCTD21	ATCTD24	ATCTD26	ATCTD27
	2'-7 1/4" (794) 2'-8" (813) 27" (685)	2'-8 1/8" (816) 2'-9" (838) 27 13/16" (707)	2'-8 3/8" (822) 2'-9" (838) 28 1/8" (714)	2'-9 1/4" (845) 2'-10" (863) 29" (736)	2'-11 1/4" (895) 3'-0" (914) 31" (787)
	1'-3 5/8" (397) 1'-4 3/8" (416) 11 5/8" (295)	1'-4 1/16" (408) 1'-4 13/16" (427) 12 1/16" (306)	1'-4 3/16" (411) 1'-4 15/16" (430) 12 3/16" (310)	1'-4 5/8" (422) 1'-5 3/8" (441) 12 5/8" (321)	1'-5 5/8" (448) 1'-6 3/8" (467) 13 5/8" (346)
	ATCTD28	ATCTD29	ATCTD29G*	ATCTD210	ATCTD30
	3'-0 1/8" (918) 3'-1" (940) 31 7/8" (810)	3'-1 1/4" (946) 3'-2" (965) 33" (838)	3'-2 1/8" (968) 3'-3" (990) 33 7/8" (861)	3'-2 3/8" (975) 3'-3" (990) 34 1/8" (867)	3'-3 1/4" (997) 3'-4" (1016) 35" (890)
	1'-6 1/16" (459) 1'-6 13/16" (478) 14 1/16" (357)	1'-6 5/8" (473) 1'-7 3/8" (492) 14 5/8" (371)	1'-7 1/16" (484) 1'-7 13/16" (503) 15 1/16" (383)	1'-7 3/16" (487) 1'-7 15/16" (506) 15 3/16" (386)	1'-7 5/8" (498) 1'-8 3/8" (518) 15 5/8" (397)
	ATCTD31	ATCTD32	ATCTD33	ATCTD33G*	ATCTD34
	3'-7 1/4" (1099) 3'-8" (1117) 39 1/16" (992)	3'-8 3/8" (1127) 3'-9" (1143) 40 3/16" (1020)	3'-11 1/4" (1200) 4'-0" (1219) 43 1/16" (1094)	4'-2 3/8" (1280) 4'-3" (1295) 46 3/16" (1174)	4'-3 1/4" (1302) 4'-4" (1321) 47 1/8" (1196)
	1'-9 5/8" (549) 1'-10 3/8" (568) 17 5/8" (448)	1'-10 3/16" (564) 1'-10 15/16" (583) 18 3/16" (462)	1'-11 5/8" (600) 2'-0 3/8" (619) 19 5/8" (498)	2'-1 3/16" (640) 2'-1 15/16" (659) 21 3/16" (538)	2'-1 5/8" (651) 2'-2 3/8" (670) 21 5/8" (549)
	ATCTD38	ATCTD39	ATCTD40	ATCTD43	ATCTD44
	4'-7 1/4" (1403) 4'-8" (1422) 51 1/8" (1298)	4'-11 1/4" (1505) 5'-0" (1524) 55 1/8" (1400)	5'-3 1/4" (1607) 5'-4" (1625) 59 1/8" (1502)	5'-7 1/4" (1708) 5'-8" (1727) 63 1/8" (1603)	
	2'-3 5/8" (702) 2'-4 3/8" (721) 23 5/8" (600)	2'-5 5/8" (752) 2'-6 3/8" (772) 25 5/8" (651)	2'-7 5/8" (803) 2'-8 3/8" (822) 27 5/8" (702)	2'-9 5/8" (854) 2'-10 3/8" (873) 29 5/8" (752)	
	ATCTD48	ATCTD50	ATCTD54	ATCTD58	
	5'-11 1/4" (1810) 6'-0" (1829) 67 1/8" (1705)	6'-3 1/4" (1911) 6'-4" (1930) 71 1/8" (1807)	6'-7 1/4" (2013) 6'-8" (2032) 75 1/8" (1909)	6'-11 1/4" (2115) 7'-0" (2134) 79 1/8" (2010)	
	2'-11 5/8" (905) 3'-0 3/8" (924) 31 5/8" (803)	3'-1 5/8" (956) 3'-2 3/8" (975) 33 5/8" (854)	3'-3 5/8" (1006) 3'-4 3/8" (1026) 35 5/8" (905)	3'-5 5/8" (1057) 3'-6 3/8" (1076) 37 5/8" (956)	
	ATCTD60	ATCTD64	ATCTD68	ATCTD70	

* "Window Dimension" always refers to outside frame-to-frame dimension.

* "Minimum Rough Opening" dimensions may need to be increased to allow for use of building wraps, flashing, sill panning, brackets, fasteners or other items. See pages 226-227 for more details.

* Dimensions in parentheses are in millimeters.

* Sized to fit over a stationary A-Series gliding patio door.

Table of Direct-Set Elliptical Window Sizes

Scale 1/8" (3) = 1'-0" (305) – 1:96

Window Dimension	3'-11 1/4" (1200)	4'-3 1/4" (1302)	4'-7 1/4" (1403)
Minimum Rough Opening	4'-0" (1219)	4'-4" (1321)	4'-8" (1423)
Unobstructed Glass	41 9/16" (1056)	45 3/4" (1162)	50 3/8" (1280)

11 7/8" (302)	1'-0 5/8" (321)	7 7/8" (200)	ATETD40
1'-0 5/8" (321)	1'-1 3/8" (340)	8 5/8" (219)	ATETD44
1'-1 1/4" (337)	1'-2" (356)	9 1/4" (235)	ATETD48
4'-11 1/4" (1505)	5'-3 1/4" (1607)	5'-7 1/4" (1708)	
5'-0" (1524)	5'-4" (1626)	5'-8" (1728)	
54 11/16" (1390)	59 1/16" (1499)	63 3/16" (1604)	
1'-2" (356)	1'-2 3/4" (375)	10" (254)	ATETD50
1'-2 3/4" (375)	1'-3 1/2" (394)	10 3/4" (273)	ATETD54
1'-3 1/2" (394)	1'-4 1/4" (413)	11 1/2" (292)	ATETD58
5'-11 1/4" (1810)	6'-3 1/4" (1911)	6'-7 1/4" (2013)	
6'-0" (1828)	6'-4" (1930)	6'-8" (2033)	
66 13/16" (1696)	70 13/16" (1799)	75 1/8" (1907)	
1'-4 1/8" (410)	1'-4 7/8" (429)	12 1/8" (308)	ATETD60
1'-4 7/8" (429)	1'-5 5/8" (448)	12 7/8" (327)	ATETD64
1'-5 5/8" (448)	1'-6 3/8" (467)	13 5/8" (346)	ATETD68
6'-11 1/4" (2115)	7'-3 1/4" (2216)	7'-7 1/4" (2318)	
7'-0" (2134)	7'-4" (2235)	7'-8" (2355)	
79 3/16" (2011)	82 7/8" (2105)	87 1/8" (2219)	
1'-6 3/8" (467)	1'-7 1/8" (486)	14 3/8" (365)	ATETD70
1'-7 1/8" (486)	1'-7 3/4" (502)	15" (381)	ATETD74
7'-10 7/16" (2399)	7'-11 1/4" (2419)	8'-0" (2438)	
7'-11" (2413)	8'-0" (2438)	8'-4" (2500)	
90 1/16" (2288)	90 7/8" (2309)	95 1/8" (2423)	
1'-8 3/8" (518)	1'-9 1/8" (537)	16 3/8" (416)	ATETD711
1'-9 1/8" (537)	1'-9 1/4" (540)	16 1/2" (419)	ATETD80
8'-10 7/16" (2704)	8'-11" (2718)	102 1/8" (2594)	
1'-10 1/2" (572)	1'-11 1/4" (591)	18 1/2" (470)	ATETD811



Custom-size windows are available in 1/8" (3) increments.

Contact your Andersen supplier for more information.



Direct-Set Half Circle



Sash-Set Half Circle



Direct-Set Elliptical



Sash-Set Elliptical

Direct-set half circle (ATCTD) and direct-set elliptical (ATETD) window sizes shown. Use

window and minimum rough opening dimensions shown for sash-set half circle (ATCT) and sash-set elliptical (ATE) window sizes. For sash-set unobstructed glass dimensions, see page 78.

All sizes shown, along with custom sizes, are available with PG upgrade.

Grille patterns shown on page 73. Details shown on page 111.























• "Window Dimension" always refers to outside frame-to-frame dimension.
 • "Minimum Rough Opening" dimensions may need to be increased to allow for use of building wraps, flashing, sill panning, brackets, fasteners or other items. See pages 226-227 for more details.
 • Dimensions in parentheses are in millimeters.

SPECIALTY WINDOWS

Table of Direct-Set Quarter Circle Window Sizes

Notes on the next page also apply to this page.

Scale 1/8" (3) = 1'-0" (305) – 1:96

Window Dimension	1'-11 1/4"	2'-0 1/8"	2'-3 1/4"	2'-5 1/4"	2'-6 1/8"																														
Minimum Rough Opening	2'-0"	2'-1"	2'-4"	2'-6"	2'-7"																														
Unobstructed Glass	19 3/16"	20 1/16"	23 3/16"	25 3/16"	26 1/16"																														
	<table border="1"> <tr><td>1'-11 1/4"</td><td>(591)</td></tr> <tr><td>2'-0"</td><td>(610)</td></tr> <tr><td>19 3/16"</td><td>(487)</td></tr> </table>  <p>ATQCTD20</p>	1'-11 1/4"	(591)	2'-0"	(610)	19 3/16"	(487)	<table border="1"> <tr><td>2'-0 1/8"</td><td>(613)</td></tr> <tr><td>2'-1"</td><td>(635)</td></tr> <tr><td>20 1/16"</td><td>(509)</td></tr> </table>  <p>ATQCTD21</p>	2'-0 1/8"	(613)	2'-1"	(635)	20 1/16"	(509)	<table border="1"> <tr><td>2'-3 1/4"</td><td>(692)</td></tr> <tr><td>2'-4"</td><td>(711)</td></tr> <tr><td>23 3/16"</td><td>(589)</td></tr> </table>  <p>ATQCTD24</p>	2'-3 1/4"	(692)	2'-4"	(711)	23 3/16"	(589)	<table border="1"> <tr><td>2'-5 1/4"</td><td>(743)</td></tr> <tr><td>2'-6"</td><td>(762)</td></tr> <tr><td>25 3/16"</td><td>(639)</td></tr> </table>  <p>ATQCTD26</p>	2'-5 1/4"	(743)	2'-6"	(762)	25 3/16"	(639)	<table border="1"> <tr><td>2'-6 1/8"</td><td>(765)</td></tr> <tr><td>2'-7"</td><td>(787)</td></tr> <tr><td>26 1/16"</td><td>(662)</td></tr> </table>  <p>ATQCTD27</p>	2'-6 1/8"	(765)	2'-7"	(787)	26 1/16"	(662)
1'-11 1/4"	(591)																																		
2'-0"	(610)																																		
19 3/16"	(487)																																		
2'-0 1/8"	(613)																																		
2'-1"	(635)																																		
20 1/16"	(509)																																		
2'-3 1/4"	(692)																																		
2'-4"	(711)																																		
23 3/16"	(589)																																		
2'-5 1/4"	(743)																																		
2'-6"	(762)																																		
25 3/16"	(639)																																		
2'-6 1/8"	(765)																																		
2'-7"	(787)																																		
26 1/16"	(662)																																		
	<table border="1"> <tr><td>2'-8 3/8"</td><td>(822)</td></tr> <tr><td>2'-9"</td><td>(838)</td></tr> <tr><td>28 5/16"</td><td>(719)</td></tr> </table>  <p>ATQCTD29G*</p>	2'-8 3/8"	(822)	2'-9"	(838)	28 5/16"	(719)	<table border="1"> <tr><td>2'-9 1/4"</td><td>(845)</td></tr> <tr><td>2'-10"</td><td>(864)</td></tr> <tr><td>29 3/16"</td><td>(741)</td></tr> </table>  <p>ATQCTD210</p>	2'-9 1/4"	(845)	2'-10"	(864)	29 3/16"	(741)	<table border="1"> <tr><td>2'-11 1/4"</td><td>(895)</td></tr> <tr><td>3'-0"</td><td>(914)</td></tr> <tr><td>31 3/16"</td><td>(792)</td></tr> </table>  <p>ATQCTD30</p>	2'-11 1/4"	(895)	3'-0"	(914)	31 3/16"	(792)	<table border="1"> <tr><td>3'-0 1/8"</td><td>(918)</td></tr> <tr><td>3'-1"</td><td>(940)</td></tr> <tr><td>32 1/16"</td><td>(814)</td></tr> </table>  <p>ATQCTD31</p>	3'-0 1/8"	(918)	3'-1"	(940)	32 1/16"	(814)	<table border="1"> <tr><td>3'-1 1/4"</td><td>(946)</td></tr> <tr><td>3'-2"</td><td>(965)</td></tr> <tr><td>33 3/16"</td><td>(843)</td></tr> </table>  <p>ATQCTD32</p>	3'-1 1/4"	(946)	3'-2"	(965)	33 3/16"	(843)
2'-8 3/8"	(822)																																		
2'-9"	(838)																																		
28 5/16"	(719)																																		
2'-9 1/4"	(845)																																		
2'-10"	(864)																																		
29 3/16"	(741)																																		
2'-11 1/4"	(895)																																		
3'-0"	(914)																																		
31 3/16"	(792)																																		
3'-0 1/8"	(918)																																		
3'-1"	(940)																																		
32 1/16"	(814)																																		
3'-1 1/4"	(946)																																		
3'-2"	(965)																																		
33 3/16"	(843)																																		
	<table border="1"> <tr><td>3'-3 1/4"</td><td>(997)</td></tr> <tr><td>3'-4"</td><td>(1016)</td></tr> <tr><td>35 3/16"</td><td>(894)</td></tr> </table>  <p>ATQCTD34</p>	3'-3 1/4"	(997)	3'-4"	(1016)	35 3/16"	(894)	<table border="1"> <tr><td>3'-5 1/4"</td><td>(1048)</td></tr> <tr><td>3'-6"</td><td>(1067)</td></tr> <tr><td>37 3/16"</td><td>(945)</td></tr> </table>  <p>ATQCTD36</p>	3'-5 1/4"	(1048)	3'-6"	(1067)	37 3/16"	(945)	<table border="1"> <tr><td>3'-7 1/4"</td><td>(1099)</td></tr> <tr><td>3'-8"</td><td>(1118)</td></tr> <tr><td>39 3/16"</td><td>(996)</td></tr> </table>  <p>ATQCTD38</p>	3'-7 1/4"	(1099)	3'-8"	(1118)	39 3/16"	(996)	<table border="1"> <tr><td>3'-8 3/8"</td><td>(1127)</td></tr> <tr><td>3'-9"</td><td>(1143)</td></tr> <tr><td>40 5/16"</td><td>(1024)</td></tr> </table>  <p>ATQCTD39</p>	3'-8 3/8"	(1127)	3'-9"	(1143)	40 5/16"	(1024)	<table border="1"> <tr><td>3'-11 1/4"</td><td>(1200)</td></tr> <tr><td>4'-0"</td><td>(1219)</td></tr> <tr><td>43 3/16"</td><td>(1097)</td></tr> </table>  <p>ATQCTD40</p>	3'-11 1/4"	(1200)	4'-0"	(1219)	43 3/16"	(1097)
3'-3 1/4"	(997)																																		
3'-4"	(1016)																																		
35 3/16"	(894)																																		
3'-5 1/4"	(1048)																																		
3'-6"	(1067)																																		
37 3/16"	(945)																																		
3'-7 1/4"	(1099)																																		
3'-8"	(1118)																																		
39 3/16"	(996)																																		
3'-8 3/8"	(1127)																																		
3'-9"	(1143)																																		
40 5/16"	(1024)																																		
3'-11 1/4"	(1200)																																		
4'-0"	(1219)																																		
43 3/16"	(1097)																																		
	<table border="1"> <tr><td>4'-7 1/4"</td><td>(1403)</td></tr> <tr><td>4'-8"</td><td>(1422)</td></tr> <tr><td>51 1/4"</td><td>(1301)</td></tr> </table>  <p>ATQCTD48</p>	4'-7 1/4"	(1403)	4'-8"	(1422)	51 1/4"	(1301)	<table border="1"> <tr><td>4'-11 1/4"</td><td>(1505)</td></tr> <tr><td>5'-0"</td><td>(1524)</td></tr> <tr><td>55 1/4"</td><td>(1402)</td></tr> </table>  <p>ATQCTD50</p>	4'-11 1/4"	(1505)	5'-0"	(1524)	55 1/4"	(1402)	<table border="1"> <tr><td>5'-3 1/4"</td><td>(1607)</td></tr> <tr><td>5'-4"</td><td>(1626)</td></tr> <tr><td>59 1/4"</td><td>(1504)</td></tr> </table>  <p>ATQCTD54</p>	5'-3 1/4"	(1607)	5'-4"	(1626)	59 1/4"	(1504)	<table border="1"> <tr><td>5'-7 1/4"</td><td>(1708)</td></tr> <tr><td>5'-8"</td><td>(1727)</td></tr> <tr><td>63 1/4"</td><td>(1606)</td></tr> </table>  <p>ATQCTD58</p>	5'-7 1/4"	(1708)	5'-8"	(1727)	63 1/4"	(1606)							
4'-7 1/4"	(1403)																																		
4'-8"	(1422)																																		
51 1/4"	(1301)																																		
4'-11 1/4"	(1505)																																		
5'-0"	(1524)																																		
55 1/4"	(1402)																																		
5'-3 1/4"	(1607)																																		
5'-4"	(1626)																																		
59 1/4"	(1504)																																		
5'-7 1/4"	(1708)																																		
5'-8"	(1727)																																		
63 1/4"	(1606)																																		
	<table border="1"> <tr><td>6'-3 1/4"</td><td>(1911)</td></tr> <tr><td>6'-4"</td><td>(1930)</td></tr> <tr><td>71 1/4"</td><td>(1809)</td></tr> </table>  <p>ATQCTD64</p>	6'-3 1/4"	(1911)	6'-4"	(1930)	71 1/4"	(1809)	<table border="1"> <tr><td>6'-7 1/4"</td><td>(2013)</td></tr> <tr><td>6'-8"</td><td>(2032)</td></tr> <tr><td>75 1/4"</td><td>(1911)</td></tr> </table>  <p>ATQCTD68</p>	6'-7 1/4"	(2013)	6'-8"	(2032)	75 1/4"	(1911)	<table border="1"> <tr><td>6'-11 1/4"</td><td>(2115)</td></tr> <tr><td>7'-0"</td><td>(2134)</td></tr> <tr><td>79 1/4"</td><td>(2012)</td></tr> </table>  <p>ATQCTD70</p>	6'-11 1/4"	(2115)	7'-0"	(2134)	79 1/4"	(2012)														
6'-3 1/4"	(1911)																																		
6'-4"	(1930)																																		
71 1/4"	(1809)																																		
6'-7 1/4"	(2013)																																		
6'-8"	(2032)																																		
75 1/4"	(1911)																																		
6'-11 1/4"	(2115)																																		
7'-0"	(2134)																																		
79 1/4"	(2012)																																		

*"Window Dimension" always refers to outside frame-to-frame dimension.
 *"Minimum Rough Opening" dimensions may need to be increased to allow for use of building wraps, flashing, sill panning, brackets, fasteners or other items. See pages 226-227 for more details.
 *Dimensions in parentheses are in millimeters.
 *Sized to fit over a stationary A-Series gliding patio door.

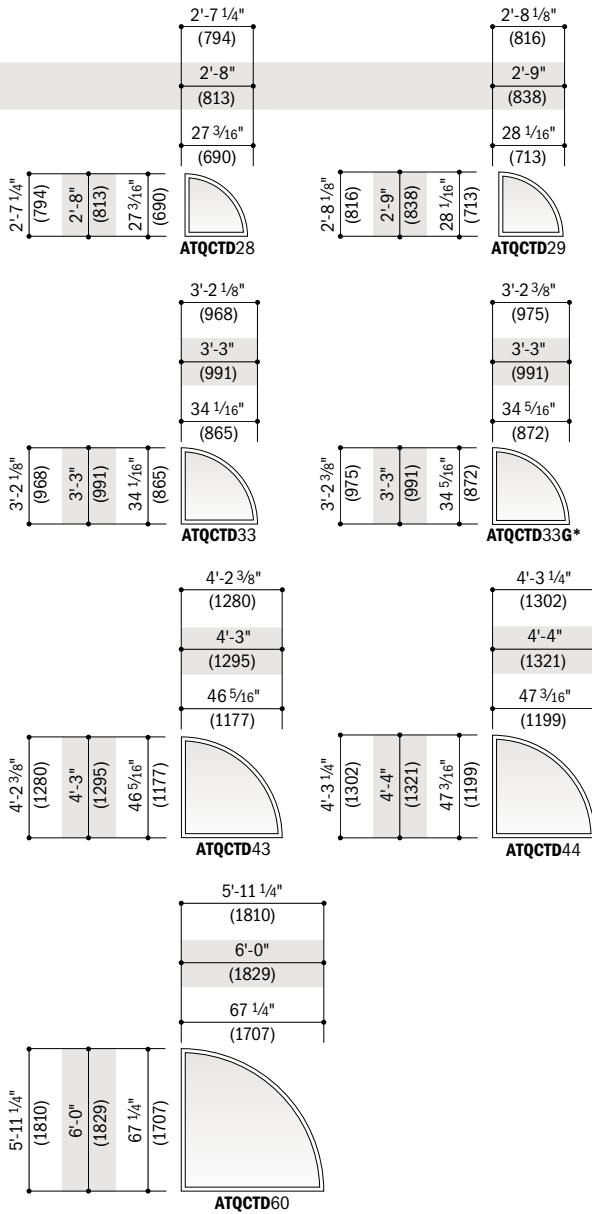

Custom-size windows are available in 1/8" (3) increments.

Contact your Andersen supplier for more information.

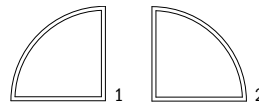

Direct-Set Quarter Circle

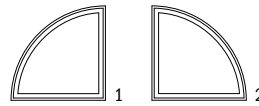

Sash-Set Quarter Circle

Direct-set quarter circle (ATQCTD) window sizes shown. Choose left facing (1) or right facing (2) as viewed from the exterior. Use window and minimum rough opening dimensions shown for sash-set quarter circle (ATQCT) window sizes. For sash-set unobstructed glass dimensions, see page 79.

All sizes shown, along with custom sizes, are available with PG upgrade.

Grille patterns shown below. Details shown on page 111.

Grille Patterns

	Colonial	Renaissance	Sunburst
Half Circle			
Quarter Circle			
Elliptical			

Number of lights and overall pattern varies with window size. Patterns may not be available in all configurations or sizes. Specified equal light and custom patterns are also available. For more grille options, see page 19 or visit andersenwindows.com/grilles.

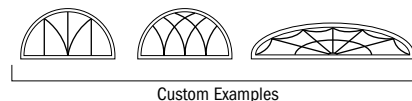

• "Window Dimension" always refers to outside frame-to-frame dimension.
 • **Minimum Rough Opening** dimensions may need to be increased to allow for use of building wraps, flashing, sill panning, brackets, fasteners or other items. See pages 226-227 for more details.
 • Dimensions in parentheses are in millimeters.
 • *Sized to fit over a stationary A-Series gliding patio door.

SPECIALTY WINDOWS

Table of Direct-Set Unequal Leg Arch Window Sizes

Scale 1/8" (3) = 1'-0" (305) – 1:96

Notes on the next page also apply to this page.

Window Dimension	1'-3 1/4" (387)	1'-7 1/4" (489)	1'-11 1/4" (591)	2'-0 1/8" (613)	2'-3 1/4" (692)	2'-5 1/4" (743)	2'-6 1/8" (765)	2'-7 1/4" (794)	2'-8 1/8" (816)	2'-8 3/8" (822)
Minimum Rough Opening	1'-4" (406)	1'-8" (508)	2'-0" (610)	2'-1" (635)	2'-4" (711)	2'-6" (762)	2'-7" (787)	2'-8" (813)	2'-9" (838)	2'-9" (838)

		CUSTOM SIZES AVAILABLE										
		Radius	36" (914)	42" (1067)	48" (1219)	60" (1524)	60" (1524)	60" (1524)	66" (1676)	66" (1676)	66" (1676)	66" (1676)
		Chord Height	3 3/8" (86)	4 5/8" (118)	6" (152)	5 1/16" (129)	6 1/2" (166)	7 5/8" (194)	7 1/4" (185)	7 1/8" (181)	8 3/8" (212)	8 1/2" (216)
		Shoulder Height	15 7/8" (403)	14 5/8" (371)	13 1/4" (337)	14 3/16" (360)	12 3/4" (323)	11 5/8" (295)	12" (304)	12 1/8" (308)	10 7/8" (277)	10 3/4" (273)
1'-7 1/4"	(489)	ATUD1418	ATUD1818	ATUD2018	ATUD2118	ATUD2418	ATUD2618	ATUD2718	ATUD2818	ATUD2918	ATUD2918G*	
1'-9 1/4"	(437)	ATUD14110	ATUD18110	ATUD20110		ATUD24110	ATUD26110		ATUD28110			
1'-11 1/4"	(591)	ATUD1420	ATUD1820	ATUD2020	ATUD2120	ATUD2420	ATUD2620	ATUD2720	ATUD2820	ATUD2920	ATUD2920G*	
2'-3 1/4"	(692)	ATUD1424	ATUD1824	ATUD2024	ATUD2124	ATUD2424	ATUD2624	ATUD2724	ATUD2824	ATUD2924	ATUD2924G*	
2'-7 1/4"	(794)	ATUD1428	ATUD1828	ATUD2028	ATUD2128	ATUD2428	ATUD2628	ATUD2728	ATUD2828	ATUD2928	ATUD2928G*	
2'-11 1/4"	(895)	ATUD1430	ATUD1830	ATUD2030	ATUD2130	ATUD2430	ATUD2630	ATUD2730	ATUD2830	ATUD2930	ATUD2930G*	

Window Dimension	3'-3 1/4" (997)	3'-7 1/4" (1099)	3'-8 3/8" (1127)	3'-11 1/4" (1200)	4'-2 3/8" (1280)	4'-3 1/4" (1302)	4'-7 1/4" (1403)
Minimum Rough Opening	3'-4" (1016)	3'-8" (1118)	3'-9" (1143)	4'-0" (1219)	4'-3" (1295)	4'-4" (1321)	4'-8" (1422)

		CUSTOM SIZES AVAILABLE							
		Radius	84" (2133)	96" (2438)	96" (2438)	96" (2438)	108" (2743)	108" (2743)	120" (3048)
		Chord Height	9 3/4" (247)	10 1/4" (261)	10 7/8" (276)	12 1/16" (316)	12 1/2" (317)	12 15/16" (329)	13 1/2" (342)
		Shoulder Height	9 1/2" (242)	9" (228)	8 3/8" (213)		8 13/16" (224)	8 5/16" (211)	7 3/4" (198)
1'-7 1/4"	(489)	ATUD3418	ATUD3818	ATUD3918					
1'-9 1/4"	(437)	ATUD34110	ATUD38110		ATUD40110			ATUD44110	ATUD48110
1'-11 1/4"	(591)	ATUD3420	ATUD3820	ATUD3920	ATUD4020	ATUD4320		ATUD4420	ATUD4820
2'-3 1/4"	(692)	ATUD3424	ATUD3824	ATUD3924	ATUD4024	ATUD4324		ATUD4424	ATUD4824
2'-7 1/4"	(794)	ATUD3428	ATUD3828	ATUD3928	ATUD4028	ATUD4328		ATUD4428	ATUD4828
2'-11 1/4"	(895)	ATUD3430	ATUD3830	ATUD3930	ATUD4030	ATUD4330		ATUD4430	ATUD4830

* "Window Dimension" always refers to outside frame-to-frame dimension.
 * "Minimum Rough Opening" dimensions may need to be increased to allow for use of building wraps, flashing, sill panning, brackets, fasteners or other items. See pages 226-227 for more details.
 * Dimensions in parentheses are in millimeters.
 * Sized to fit over a stationary A-Series gliding patio door.

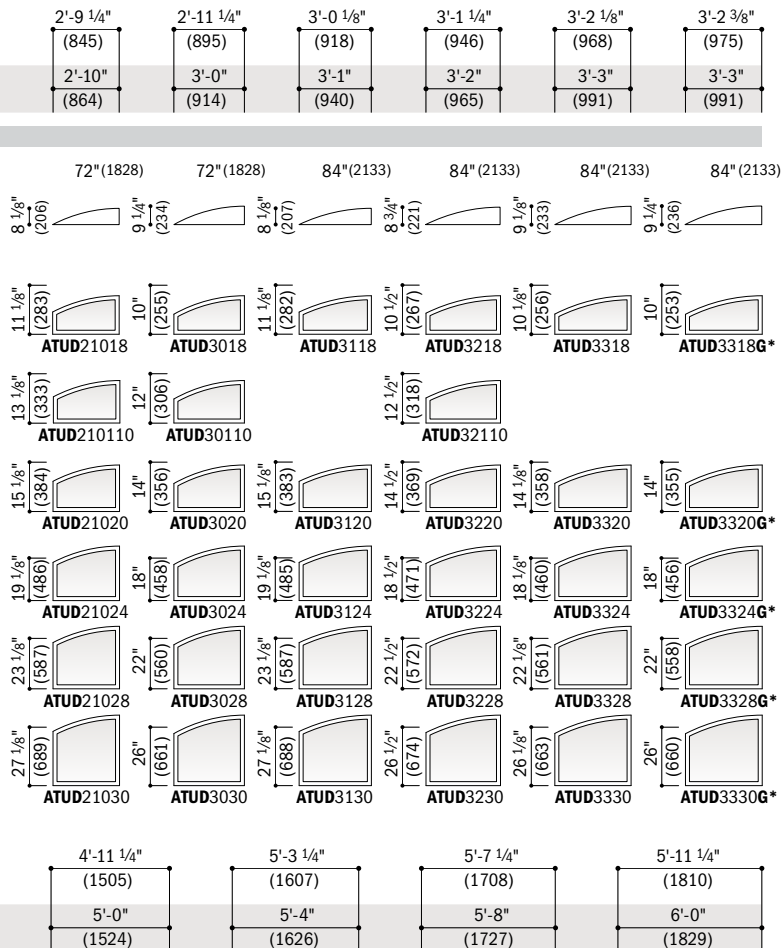

Custom-size windows are available in 1/8" (3) increments. Contact your Andersen supplier for more information.

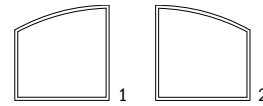

Direct-Set Unequal Leg Arch

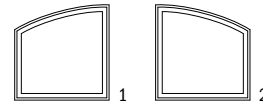

Sash-Set Unequal Leg Arch

Direct-set unequal leg arch (ATUD) window sizes shown.

Choose left facing (1) or right facing (2) as viewed from the exterior. Use window and minimum rough opening dimensions shown for sash-set unequal leg arch (ATU) window sizes.

All sizes shown, along with custom sizes, are available with PG upgrade.

Grille patterns shown below. Details shown on page 111.

Grille Patterns

	Colonial	Renaissance	Sunburst
Unequal Leg Arch			

Number of lights and overall pattern varies with window size. Patterns may not be available in all configurations or sizes. Specified equal light and custom patterns are also available. For more grille options, see page 19 or visit andersenwindows.com/grilles.

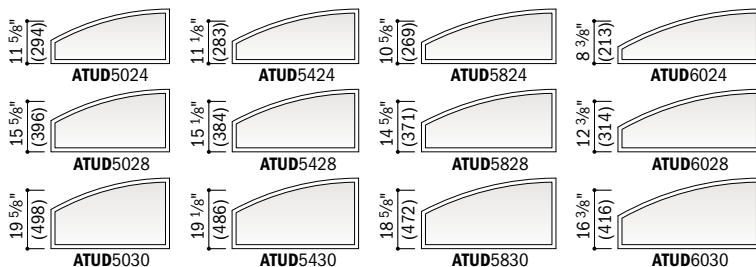

- *"Window Dimension" always refers to outside frame-to-frame dimension.
- *"Minimum Rough Opening" dimensions may need to be increased to allow for use of building wraps, flashing, sill panning, brackets, fasteners or other items. See pages 226-227 for more details.
- *Dimensions in parentheses are in millimeters.
- *Sized to fit over a stationary A-Series gliding patio door.

SPECIALTY WINDOWS

Table of Direct-Set Octagon Window Sizes

Scale 1/8" (3) = 1'-0" (305) – 1:96

Window Dimension	1'-11 1/4" (591)	2'-3 1/4" (692)	2'-11 1/4" (895)	3'-11 1/4" (1200)	5'-11 1/4" (1810)
Minimum Rough Opening	2'-0" (610)	2'-4" (711)	3'-0" (914)	4'-0" (1219)	6'-0" (1829)
Unobstructed Glass	19 1/4" (489)	23 1/4" (591)	31 1/4" (794)	43 1/4" (1099)	67 1/4" (1708)



ATOCD20



ATOCD24



ATOCD30



ATOCD40



ATOCD60



Custom-size octagon and circle windows

are available in 1/8" (3) increments. Contact your Andersen supplier for more information.

Oval windows are not available in custom sizes.

Table of Direct-Set Circle Window Sizes

Scale 1/8" (3) = 1'-0" (305) – 1:96

Window Dimension	1'-11 1/4" (591)	2'-3 1/4" (692)	2'-11 1/4" (895)	3'-11 1/4" (1200)	5'-11 1/4" (1810)
Minimum Rough Opening	2'-0" (610)	2'-4" (711)	3'-0" (914)	4'-0" (1219)	6'-0" (1829)
Unobstructed Glass	19 1/4" (489)	23 1/4" (591)	31 1/4" (794)	43 1/4" (1099)	67 1/4" (1708)



ACRD20



ACRD24



ACRD30



ACRD40



ACRD60

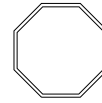

Direct-Set Octagon

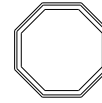

Sash-Set Octagon

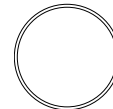

Direct-Set Circle

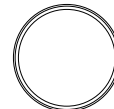

Sash-Set Circle

Direct-set octagon (ATOCD) and direct-set circle (ACRD) window sizes shown.

Use window and minimum rough opening dimensions shown for sash-set octagon (ATOC) and sash-set circle (ACR) window sizes. For sash-set unobstructed glass dimensions, see page 79. All sizes shown, along with custom sizes, are available with PG upgrade.

Table of Direct-Set Oval Window Sizes

Scale 1/8" (3) = 1'-0" (305) – 1:96

Window Dimension	1'-7 1/4" (489)	1'-11 1/4" (591)	2'-11 1/4" (895)
Minimum Rough Opening	1'-8" (508)	2'-0" (610)	3'-0" (914)
Unobstructed Glass	15 1/4" (387)	19 1/4" (489)	31 1/4" (794)

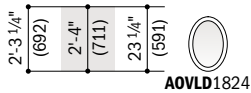

AOVD1824

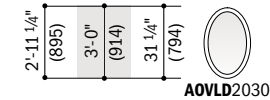

AOVD2030

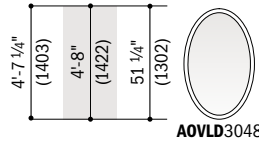

AOVD3048

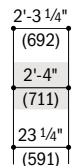

AOVD2418

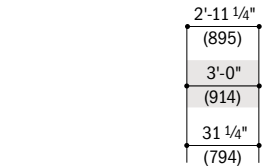

AOVD3020

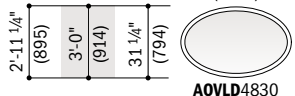

AOVD4830

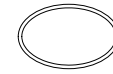

Direct-Set Oval

Oval windows are available direct-set only, and can be installed either vertically or horizontally. All sizes shown are available with PG upgrade.

Details shown on page 111.

Grille patterns are available in colonial, Renaissance, sunburst, specified equal light and custom patterns.

For more grille options, see page 19 or visit

andersenwindows.com/grilles.

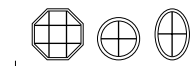

Colonial Examples

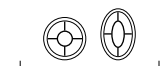

Renaissance Examples

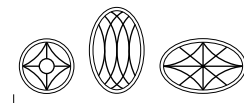

Custom Examples

* "Window Dimension" always refers to outside frame-to-frame dimension.

* "Minimum Rough Opening" dimensions may need to be increased to allow for use of building wraps, flashing, sill panning, brackets, fasteners or other items. See pages 226-227 for more details.

* Dimensions in parentheses are in millimeters.

Direct-Set Half Circle Window Area Specifications

Window Number	Glass Area Sq. Ft./ (m ²)
ATCTD20	0.75 (0.07)
ATCTD21	0.83 (0.08)
ATCTD24	1.15 (0.11)
ATCTD26	1.39 (0.13)
ATCTD27	1.50 (0.14)
ATCTD28	1.65 (0.15)
ATCTD29	1.77 (0.16)
ATCTD29G	1.80 (0.17)
ATCTD210	1.93 (0.18)
ATCTD30	2.23 (0.21)
ATCTD31	2.37 (0.22)
ATCTD32	2.55 (0.24)
ATCTD33	2.70 (0.25)
ATCTD33G	2.75 (0.26)
ATCTD34	2.90 (0.27)
ATCTD38	3.66 (0.34)
ATCTD39	3.89 (0.36)
ATCTD40	4.50 (0.42)
ATCTD43	5.22 (0.49)
ATCTD44	5.43 (0.50)
ATCTD48	6.45 (0.60)
ATCTD50	7.56 (0.70)
ATCTD54	8.75 (0.81)
ATCTD58	10.03 (0.93)
ATCTD60	11.40 (1.06)
ATCTD64	12.86 (1.19)
ATCTD68	14.40 (1.34)
ATCTD70	16.03 (1.49)

*Dimensions in parentheses are in square meters.

Direct-Set Elliptical Window Area Specifications

Window Number	Glass Area Sq. Ft./ (m ²)
ATETD40	1.69 (0.16)
ATETD44	2.01 (0.19)
ATETD48	2.57 (0.24)
ATETD50	2.86 (0.27)
ATETD54	3.41 (0.32)
ATETD58	3.98 (0.37)
ATETD60	4.27 (0.40)
ATETD64	4.82 (0.45)
ATETD68	5.60 (0.52)
ATETD70	6.26 (0.58)
ATETD74	6.62 (0.62)
ATETD711	7.92 (0.74)
ATETD80	8.00 (0.74)
ATETD811	10.13 (0.94)

*Dimensions in parentheses are in square meters.

Direct-Set Octagon Window Area Specifications

Window Number	Glass Area Sq. Ft./ (m ²)
ATOCD20	2.13 (0.20)
ATOCD24	3.11 (0.29)
ATOCD30	5.62 (0.52)
ATOCD40	10.76 (1.00)
ATOCD60	26.02 (2.42)

*Dimensions in parentheses are in square meters.

Direct-Set Circle & Oval Window Area Specifications

Window Number	Glass Area Sq. Ft./ (m ²)
ACRD20	2.02 (0.19)
ACRD24	2.95 (0.27)
ACRD30	5.33 (0.49)
ACRD40	10.20 (0.95)
ACRD60	24.67 (2.29)
AOVLD1824/AOVLD2418	1.93 (0.18)
AOVLD2030/AOVLD3020	3.27 (0.30)
AOVLD3048/AOVLD4830	8.71 (0.81)

*Dimensions in parentheses are in square meters.

Direct-Set Quarter Circle Window Area Specifications

Window Number	Glass Area Sq. Ft./ (m ²)
ATQCTD20	1.90 (0.18)
ATQCTD21	2.08 (0.19)
ATQCTD24	2.80 (0.26)
ATQCTD26	3.32 (0.31)
ATQCTD27	3.56 (0.33)
ATQCTD28	3.88 (0.36)
ATQCTD29	4.14 (0.38)
ATQCTD29G	4.22 (0.39)
ATQCTD210	4.49 (0.42)
ATQCTD30	5.13 (0.48)
ATQCTD31	5.43 (0.50)
ATQCTD32	5.83 (0.54)
ATQCTD33	6.14 (0.57)
ATQCTD33G	6.23 (0.58)
ATQCTD34	6.56 (0.61)
ATQCTD36	7.34 (0.68)
ATQCTD38	8.16 (0.76)
ATQCTD39	8.64 (0.80)
ATQCTD40	9.94 (0.92)
ATQCTD43	11.45 (1.06)
ATQCTD44	11.89 (1.10)
ATQCTD48	14.01 (1.30)
ATQCTD50	16.31 (1.52)
ATQCTD54	18.79 (1.75)
ATQCTD58	21.44 (1.99)
ATQCTD60	24.26 (2.25)
ATQCTD64	27.26 (2.53)
ATQCTD68	30.43 (2.83)
ATQCTD70	33.78 (3.14)

*Dimensions in parentheses are in square meters.

Direct-Set Unequal Leg Arch Window Area Specifications

Window Number	Glass Area Sq. Ft./ (m ²)
ATUD1418	1.11 (0.10)
ATUD14110	1.27 (0.12)
ATUD1420	1.42 (0.13)
ATUD1424	1.74 (0.16)
ATUD1428	2.05 (0.19)
ATUD1430	2.36 (0.22)
ATUD1818	1.46 (0.14)
ATUD18110	1.67 (0.16)
ATUD1820	1.89 (0.18)
ATUD1824	2.31 (0.21)
ATUD1828	2.73 (0.25)
ATUD1830	3.16 (0.29)
ATUD2018	1.79 (0.17)
ATUD20110	2.06 (0.19)
ATUD2020	2.32 (0.22)
ATUD2024	2.86 (0.27)
ATUD2028	3.39 (0.32)
ATUD2030	3.93 (0.36)
ATUD2118	1.91 (0.18)
ATUD2120	2.47 (0.23)
ATUD2124	3.03 (0.28)
ATUD2128	3.59 (0.33)
ATUD2130	4.15 (0.39)
ATUD2418	2.13 (0.20)
ATUD24110	2.45 (0.23)
ATUD2420	2.78 (0.26)
ATUD2424	3.42 (0.32)
ATUD2428	4.07 (0.38)
ATUD2430	4.71 (0.44)
ATUD2618	2.26 (0.21)
ATUD26110	2.61 (0.24)
ATUD2620	2.96 (0.27)
ATUD2624	3.66 (0.34)
ATUD2628	4.36 (0.41)
ATUD2630	5.06 (0.47)
ATUD2718	2.35 (0.22)
ATUD2720	3.08 (0.29)
ATUD2724	3.80 (0.35)
ATUD2728	4.53 (0.42)
ATUD2730	5.25 (0.49)
ATUD2818	2.42 (0.22)
ATUD28110	2.80 (0.26)
ATUD2820	3.18 (0.29)
ATUD2824	3.93 (0.37)
ATUD2828	4.69 (0.44)
ATUD2830	5.45 (0.51)
ATUD2918	2.47 (0.23)
ATUD2920	3.25 (0.30)
ATUD2924	4.03 (0.37)
ATUD2928	4.81 (0.45)
ATUD2930	5.59 (0.52)
ATUD2918G	2.48 (0.23)
ATUD2920G	3.27 (0.30)
ATUD2924G	4.06 (0.38)
ATUD2928G	4.84 (0.45)
ATUD2930G	5.63 (0.52)
ATUD21018	2.58 (0.24)
ATUD210110	2.98 (0.28)
ATUD21020	3.39 (0.31)
ATUD21024	4.20 (0.39)

Window Number	Glass Area Sq. Ft./ (m ²)
ATUD21028	5.01 (0.47)
ATUD21030	5.83 (0.54)
ATUD3018	2.68 (0.25)
ATUD30110	3.11 (0.29)
ATUD3020	3.55 (0.33)
ATUD3024	4.42 (0.41)
ATUD3028	5.28 (0.49)
ATUD3030	6.15 (0.57)
ATUD3118	2.83 (0.26)
ATUD3120	3.72 (0.35)
ATUD3124	4.61 (0.43)
ATUD3128	5.50 (0.51)
ATUD3130	6.40 (0.59)
ATUD3218	2.88 (0.27)
ATUD32110	3.35 (0.31)
ATUD3220	3.81 (0.35)
ATUD3224	4.73 (0.44)
ATUD3228	5.66 (0.53)
ATUD3230	6.58 (0.61)
ATUD3318	2.93 (0.27)
ATUD3320	3.88 (0.36)
ATUD3324	4.82 (0.45)
ATUD3328	5.77 (0.54)
ATUD3330	6.72 (0.62)
ATUD3318G	2.94 (0.27)
ATUD3320G	3.89 (0.36)
ATUD3324G	4.85 (0.45)
ATUD3328G	5.80 (0.54)
ATUD3330G	6.76 (0.63)
ATUD3418	2.98 (0.28)
ATUD34110	3.47 (0.32)
ATUD3420	3.96 (0.37)
ATUD3424	4.94 (0.46)
ATUD3428	5.92 (0.55)
ATUD3430	6.90 (0.64)
ATUD3818	3.27 (0.30)
ATUD38110	3.81 (0.35)
ATUD3820	4.36 (0.40)
ATUD3824	5.45 (0.51)
ATUD3828	6.54 (0.61)
ATUAD3830	7.63 (0.71)
ATUAD3918	3.31 (0.31)
ATUAD3920	4.43 (0.41)
ATUAD3924	5.55 (0.52)
ATUAD3928	6.67 (0.62)
ATUAD3930	7.79 (0.72)
ATUAD40110	4.00 (0.37)
ATUAD4020	4.60 (0.43)
ATUAD4024	5.80 (0.54)
ATUAD4028	7.00 (0.65)
ATUAD4030	8.20 (0.76)
ATUAD4318	4.92 (0.46)
ATUAD4320	6.21 (0.58)
ATUAD4324	7.50 (0.70)
ATUAD4328	8.79 (0.82)
ATUAD44110	4.31 (0.40)
ATUAD4420	4.97 (0.46)
ATUAD4424	6.28 (0.58)
ATUAD4428	7.59 (0.71)

*Dimensions in parentheses are in square meters.

continued on next page

SPECIALTY WINDOWS

Direct-Set Unequal Leg Arch Window Area Specifications *(continued)*

Window Number	Glass Area Sq. Ft./ (m ²)
ATUAD4430	8.90 (0.83)
ATUAD48110	4.61 (0.43)
ATUAD4820	5.32 (0.49)
ATUAD4824	6.74 (0.63)
ATUAD4828	8.17 (0.76)
ATUAD4830	9.59 (0.89)
ATUAD5024	7.01 (0.65)
ATUAD5028	8.54 (0.79)
ATUAD5030	10.08 (0.94)
ATUAD5424	7.45 (0.69)
ATUAD5428	9.09 (0.84)
ATUAD5430	10.74 (1.00)
ATUAD5824	7.87 (0.73)
ATUAD5828	9.63 (0.89)
ATUAD5830	11.38 (1.06)
ATUAD6024	8.05 (0.75)
ATUAD6028	9.91 (0.92)
ATUAD6030	11.78 (1.09)

* Dimensions in parentheses are in square meters.

Window Number	Glass Area Sq. Ft./ (m ²)
ATU2028	2.62 (0.24)
ATU2030	3.08 (0.29)
ATU2118	1.34 (0.12)
ATU2120	1.83 (0.17)
ATU2124	2.31 (0.21)
ATU2128	2.80 (0.26)
ATU2130	3.28 (0.30)
ATU2418	1.51 (0.14)
ATU24110	1.80 (0.17)
ATU2420	2.09 (0.19)
ATU2424	2.66 (0.25)
ATU2428	3.23 (0.30)
ATU2430	3.80 (0.35)
ATU2618	1.61 (0.15)
ATU26110	1.92 (0.18)
ATU2620	2.24 (0.21)
ATU2624	2.86 (0.27)
ATU2628	3.49 (0.32)
ATU2630	4.12 (0.38)
ATU2718	1.69 (0.16)
ATU2720	2.34 (0.22)
ATU2724	2.99 (0.28)
ATU2728	3.64 (0.34)
ATU2730	4.30 (0.40)
ATU2818	1.74 (0.16)
ATU28110	2.08 (0.19)
ATU2820	2.42 (0.22)
ATU2824	3.10 (0.29)
ATU2828	3.79 (0.35)
ATU2830	4.47 (0.42)
ATU2918	1.77 (0.16)
ATU2920	2.48 (0.23)
ATU2924	3.19 (0.30)
ATU2928	3.89 (0.36)
ATU2930	4.60 (0.43)
ATU2918G	1.78 (0.17)
ATU2920G	2.50 (0.23)
ATU2924G	3.21 (0.30)
ATU2928G	3.92 (0.36)
ATU2930G	4.64 (0.43)
ATU21018	1.86 (0.17)

Window Number	Glass Area Sq. Ft./ (m ²)
ATU210110	2.23 (0.21)
ATU21020	2.60 (0.24)
ATU21024	3.34 (0.31)
ATU21028	4.08 (0.38)
ATU21030	4.82 (0.45)
ATU3018	1.93 (0.18)
ATU30110	2.33 (0.22)
ATU3020	2.73 (0.25)
ATU3024	3.52 (0.33)
ATU3028	4.32 (0.40)
ATU3030	5.11 (0.47)
ATU3118	2.06 (0.19)
ATU3120	2.88 (0.27)
ATU3124	3.70 (0.34)
ATU3128	4.51 (0.42)
ATU3130	5.33 (0.50)
ATU3218	2.10 (0.20)
ATU32110	2.53 (0.23)
ATU3220	2.95 (0.27)
ATU3224	3.80 (0.35)
ATU3228	4.65 (0.43)
ATU3230	5.50 (0.51)
ATU3318	2.13 (0.20)
ATU3320	3.00 (0.28)
ATU3324	3.88 (0.36)
ATU3328	4.75 (0.44)
ATU3330	5.63 (0.52)
ATU3318G	2.14 (0.20)
ATU3320G	3.02 (0.28)
ATU3324G	3.90 (0.36)
ATU3328G	4.78 (0.44)
ATU3330G	5.66 (0.53)
ATU3418	2.16 (0.20)
ATU34110	2.62 (0.24)
ATU3420	3.07 (0.29)
ATU3424	3.98 (0.37)
ATU3428	4.88 (0.45)
ATUA3430	5.79 (0.54)
ATUA3818	2.38 (0.22)
ATUA38110	2.89 (0.27)
ATUA3820	3.40 (0.32)

Window Number	Glass Area Sq. Ft./ (m ²)
ATUA3824	4.42 (0.41)
ATUA3828	5.43 (0.50)
ATUA3830	6.45 (0.60)
ATUA3918	2.41 (0.22)
ATUA3920	3.46 (0.32)
ATUA3924	4.50 (0.42)
ATUA3928	5.55 (0.52)
ATUA3930	6.60 (0.61)
ATUA40110	3.02 (0.28)
ATUA4020	3.58 (0.33)
ATUA4024	4.71 (0.44)
ATUA4028	5.84 (0.54)
ATUA4030	6.96 (0.65)
ATUA4318	3.85 (0.36)
ATUA4320	5.06 (0.47)
ATUA4324	6.28 (0.58)
ATUA4328	7.49 (0.70)
ATUA44110	3.26 (0.30)
ATUA4420	3.88 (0.36)
ATUA4424	5.12 (0.48)
ATUA4428	6.36 (0.59)
ATUA4430	7.60 (0.71)
ATUA48110	3.49 (0.32)
ATUA4820	4.17 (0.39)
ATUA4824	5.52 (0.51)
ATUA4828	6.87 (0.64)
ATUA4830	8.22 (0.76)
ATUA5024	5.72 (0.53)
ATUA5028	7.18 (0.67)
ATUA5030	8.64 (0.80)
ATUA5424	6.09 (0.57)
ATUA5428	7.66 (0.71)
ATUA5430	9.23 (0.86)
ATUA5824	6.45 (0.60)
ATUA5828	8.13 (0.76)
ATUA5830	9.81 (0.91)
ATUA6024	6.56 (0.61)
ATUA6028	8.36 (0.78)
ATUA6030	10.15 (0.94)

* Dimensions in parentheses are in square meters.

Sash-Set Unequal Leg Arch Window Area Specifications

Window Number	Glass Area Sq. Ft./ (m ²)
ATU1418	0.69 (0.06)
ATU14110	0.81 (0.08)
ATU1420	0.93 (0.09)
ATU1424	1.17 (0.11)
ATU1428	1.41 (0.13)
ATU1430	1.65 (0.15)
ATU1818	0.98 (0.09)
ATU18110	1.15 (0.11)
ATU1820	1.33 (0.12)
ATU1824	1.68 (0.16)
ATU1828	2.03 (0.19)
ATU1830	2.38 (0.22)
ATU2018	1.24 (0.12)
ATU20110	1.47 (0.14)
ATU2020	1.70 (0.16)
ATU2024	2.16 (0.20)

Sash-Set Half Circle Window Unobstructed Glass Dimensions and Area Specifications

Window Number	Unobstructed Glass Width Inches/(mm)	Unobstructed Glass Height Inches/(mm)	Glass Area Sq. Ft./ (m ²)
ATCT20	15 ³ / ₁₆ " (386)	5" (126)	0.38 (0.04)
ATCT21	16 ¹ / ₈ " (410)	5 ⁷ / ₁₆ " (137)	0.44 (0.04)
ATCT24	19 ¹ / ₂ " (495)	7" (177)	0.69 (0.06)
ATCT26	21 ⁹ / ₁₆ " (548)	8" (202)	0.88 (0.08)
ATCT27	22 ¹ / ₂ " (572)	8 ⁷ / ₁₆ " (214)	0.97 (0.09)
ATCT28	23 ¹¹ / ₁₆ " (601)	9" (228)	1.09 (0.10)
ATCT29	24 ⁹ / ₁₆ " (624)	9 ⁷ / ₁₆ " (239)	1.19 (0.11)
ATCT29G	24 ¹³ / ₁₆ " (631)	9 ⁹ / ₁₆ " (242)	1.22 (0.11)
ATCT210	25 ¹ / ₈ " (654)	10" (253)	1.32 (0.12)
ATCT30	27 ¹³ / ₁₆ " (706)	11" (279)	1.57 (0.15)
ATCT31	28 ¹¹ / ₁₆ " (729)	11 ⁷ / ₁₆ " (290)	1.69 (0.16)
ATCT32	29 ⁷ / ₈ " (758)	12" (304)	1.85 (0.17)
ATCT33	30 ³ / ₄ " (781)	12 ⁷ / ₁₆ " (315)	1.98 (0.18)
ATCT33G	31" (788)	12 ⁹ / ₁₆ " (318)	2.02 (0.19)

Window Number	Unobstructed Glass Width Inches/(mm)	Unobstructed Glass Height Inches/(mm)	Glass Area Sq. Ft./ (m ²)
ATCT34	31 ¹⁵ / ₁₆ " (810)	13" (329)	2.15 (0.20)
ATCT38	36" (914)	15" (380)	2.81 (0.26)
ATCT39	37 ¹ / ₈ " (943)	15 ⁹ / ₁₆ " (395)	3.01 (0.28)
ATCT40	40 ¹ / ₂ " (1017)	17" (431)	3.56 (0.33)
ATCT43	43 ³ / ₁₆ " (1098)	18 ⁹ / ₁₆ " (471)	4.21 (0.39)
ATCT44	44 ¹ / ₈ " (1120)	19" (482)	4.40 (0.41)
ATCT48	48 ¹ / ₈ " (1223)	21" (533)	5.32 (0.49)
ATCT50	52 ³ / ₁₆ " (1325)	23" (583)	6.33 (0.59)
ATCT54	56 ³ / ₁₆ " (1428)	25" (634)	7.43 (0.69)
ATCT58	60 ¹ / ₄ " (1530)	27" (685)	8.62 (0.80)
ATCT60	64 ¹ / ₄ " (1632)	29" (736)	9.89 (0.92)
ATCT64	68 ¹ / ₄ " (1734)	31" (787)	11.25 (1.04)
ATCT68	72 ³ / ₁₆ " (1836)	33" (837)	12.70 (1.18)
ATCT70	76 ⁵ / ₁₆ " (1938)	35" (888)	14.23 (1.32)

* Dimensions in parentheses are in millimeters or square meters.

Sash-Set Elliptical Window Unobstructed Glass Dimensions and Area Specifications

Window Number	Unobstructed Glass Width Inches/(mm)	Unobstructed Glass Height Inches/(mm)	Glass Area Sq. Ft./ (m ²)
ATET40	36 ¹ / ₂ " (927)	5 ¹ / ₄ " (133)	0.94 (0.09)
ATET44	40 ³ / ₄ " (1035)	6" (152)	1.18 (0.11)
ATET48	46 ¹ / ₁₆ " (1179)	6 ⁹ / ₁₆ " (167)	1.63 (0.15)
ATET50	50 ⁵ / ₈ " (1286)	7 ³ / ₈ " (187)	1.84 (0.17)
ATET54	55 ¹ / ₂ " (1410)	8 ¹ / ₈ " (206)	2.30 (0.21)
ATET58	60 ¹ / ₁₆ " (1525)	8 ⁷ / ₈ " (225)	2.78 (0.26)
ATET60	63" (1601)	9 ¹ / ₂ " (241)	3.01 (0.28)
ATET64	67 ¹ / ₈ " (1705)	10 ¹ / ₄ " (260)	3.48 (0.32)
ATET68	71 ⁷ / ₈ " (1826)	11" (279)	4.17 (0.39)
ATET70	76 ¹ / ₈ " (1934)	11 ³ / ₄ " (298)	4.74 (0.44)
ATET74	79 ³ / ₈ " (2016)	12 ³ / ₈ " (314)	5.05 (0.47)
ATET711	86 ¹ / ₁₆ " (2201)	13 ³ / ₄ " (348)	6.20 (0.58)
ATET80	87 ¹ / ₂ " (2222)	13 ⁷ / ₈ " (352)	6.27 (0.58)
ATET811	98 ¹³ / ₁₆ " (2509)	15 ¹ / ₈ " (402)	8.18 (0.76)

* Dimensions in parentheses are in millimeters or square meters.

Sash-Set Quarter Circle Window Unobstructed Glass Dimensions and Area Specifications

Window Number	Unobstructed Glass Width Inches/mm	Unobstructed Glass Height Inches/mm	Glass Area Sq. Ft./ (m ²)
ATQCT20	16 5/16" (414)	16 5/16" (414)	1.33 (0.12)
ATQCT21	17 3/16" (437)	17 3/16" (437)	1.48 (0.14)
ATQCT24	20 3/8" (517)	20 3/8" (517)	2.10 (0.19)
ATQCT26	22 3/8" (568)	22 3/8" (568)	2.55 (0.24)
ATQCT27	23 1/4" (591)	23 1/4" (591)	2.76 (0.26)
ATQCT28	24 3/8" (620)	24 3/8" (620)	3.04 (0.28)
ATQCT29	25 1/4" (642)	25 1/4" (642)	3.27 (0.30)
ATQCT29G	25 1/2" (648)	25 1/2" (648)	3.34 (0.31)
ATQCT210	26 1/16" (671)	26 1/16" (671)	3.58 (0.33)
ATQCT30	28 7/16" (722)	28 7/16" (722)	4.16 (0.39)
ATQCT31	29 5/16" (744)	29 5/16" (744)	4.43 (0.41)
ATQCT32	30 7/16" (773)	30 7/16" (773)	4.79 (0.44)
ATQCT33	31 5/16" (795)	31 5/16" (795)	5.08 (0.47)
ATQCT33G	31 9/16" (802)	31 9/16" (802)	5.16 (0.48)
ATQCT34	32 1/16" (824)	32 1/16" (824)	5.46 (0.51)
ATQCT36	34 7/16" (875)	34 7/16" (875)	6.17 (0.57)
ATQCT38	36 7/16" (926)	36 7/16" (926)	6.93 (0.64)
ATQCT39	37 9/16" (955)	37 9/16" (955)	7.37 (0.68)
ATQCT40	40 7/16" (1028)	40 7/16" (1028)	8.57 (0.80)
ATQCT43	43 5/8" (1107)	43 5/8" (1107)	9.98 (0.93)
ATQCT44	44 1/2" (1130)	44 1/2" (1130)	10.39 (0.97)
ATQCT48	48 1/2" (1232)	48 1/2" (1232)	12.38 (1.15)
ATQCT50	52 1/2" (1333)	52 1/2" (1333)	14.55 (1.35)
ATQCT54	56 1/2" (1435)	56 1/2" (1435)	16.89 (1.57)
ATQCT58	60 1/2" (1537)	60 1/2" (1537)	19.41 (1.80)
ATQCT60	64 1/2" (1639)	64 1/2" (1639)	22.10 (2.05)
ATQCT64	68 1/2" (1740)	68 1/2" (1740)	24.97 (2.32)
ATQCT68	72 1/2" (1842)	72 1/2" (1842)	28.01 (2.60)
ATQCT70	76 1/2" (1944)	76 1/2" (1944)	31.22 (2.90)

* Dimensions in parentheses are in millimeters or square meters.

Sash-Set Octagon & Circle Window Unobstructed Glass Dimensions and Area Specifications

Window Number	Unobstructed Glass Width Inches/(mm)	Unobstructed Glass Height Inches/(mm)	Glass Area Sq. Ft./ (m ²)
ATOC20	16 5/8" (421)	16 5/8" (421)	1.58 (0.15)
ATOC24	20 5/8" (523)	20 5/8" (523)	2.44 (0.23)
ATOC30	28 5/8" (726)	28 5/8" (726)	4.70 (0.44)
ATOC40	40 5/8" (1031)	40 5/8" (1031)	9.48 (0.88)
ATOC60	64 5/8" (1641)	64 5/8" (1641)	24.00 (2.23)
ACR20	16 5/8" (421)	16 5/8" (421)	1.50 (0.14)
ACR24	20 5/8" (523)	20 5/8" (523)	2.31 (0.21)
ACR30	28 5/8" (726)	28 5/8" (726)	4.46 (0.41)
ACR40	40 5/8" (1031)	40 5/8" (1031)	8.99 (0.83)
ACR60	64 5/8" (1641)	64 5/8" (1641)	22.76 (2.11)

* Dimensions in parentheses are in millimeters or square meters.

Custom-Sized Trapezoid Windows



Trapezoid windows are available in custom sizes in 1/8" (3) increments.

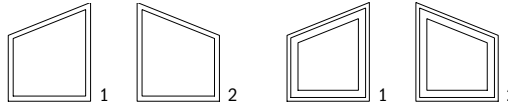

Direct-Set Trapezoid

Sash-Set Trapezoid

Available direct-set or sash-set. Choose left facing (1) or right facing (2) as viewed from the exterior. Available with PG upgrade.

Design Criteria

Listed below are some factors that must be considered when deciding on a custom-size trapezoid window.

Minimum and Maximum Limits

Trapezoid windows may be assembled in custom sizes with these limitations:

- **MAXIMUM FRAME AREA: 65 sq. ft. or 6.04 m² for Low-E4[®] tempered glass**
- **Square footage is based on a square or rectangular shape**
- **For direct-set windows, no side may be less than 6" (152) and is dependent on slope**
- **For sash-set windows, no side may be less than 8 1/2" (216) and is dependent on slope**
- **Minimum cut angle is 12[°]**

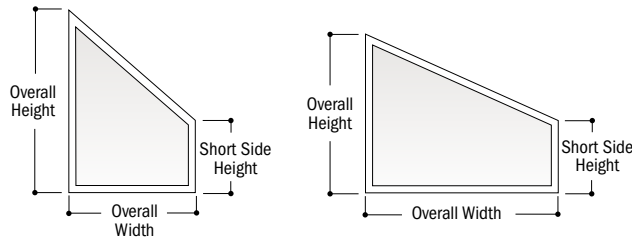

Specify overall width at sill, overall height, and short side height.

Slope is often designed to match a roof's pitch. Contact your Andersen supplier for more information.

Details shown on page 111.

Grille patterns are available in custom patterns. For more grille options, see page 19 or visit andersenwindows.com/grilles.

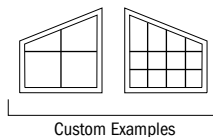

SPECIALTY WINDOWS

Table of Direct-Set Arch Window Sizes

Scale 1/8" (3) = 1'-0" (305) – 1:96

Notes on page 85 also apply to this page.

Window Dimension	1'-11 1/4" (591)	2'-0 1/8" (613)	2'-3 1/4" (692)	2'-5 1/4" (743)	2'-6 1/8" (765)	2'-7 1/4" (794)	2'-8 1/8" (816)	2'-8 3/8" (822)	2'-9 1/4" (845)
Minimum Rough Opening	2'-0" (610)	2'-1" (635)	2'-4" (711)	2'-6" (762)	2'-7" (787)	2'-8" (813)	2'-9" (838)	2'-9" (838)	2'-10" (864)
Unobstructed Glass	19 1/4" (489)	20 1/8" (511)	23 1/4" (591)	25 1/4" (641)	26 1/8" (664)	27 1/4" (692)	28 1/8" (714)	28 3/8" (721)	29 1/4" (743)

CUSTOM SIZES AVAILABLE

Minimum Rough Opening = window height + 3/4" (19)

Unobstructed Glass = window height - 4" (102)

CUSTOM SIZES AVAILABLE

Window height shown in table	Radius	24"(610)	30"(762)	30"(762)	30"(762)	36"(914)	36"(914)	36"(914)	36"(914)	36"(914)	36"(914)
	Chord Height	3" (76)	2 17/32" (64)	3 9/32" (88)	3 13/16" (97)	3 5/16" (84)	3 9/16" (91)	3 25/32" (96)	3 27/32" (98)	4 1/16" (103)	
	Shoulder Height	11 1/4" (286)	1'-1 25/32" (350)	1'-2 17/32" (369)	1'-3 1/16" (382)	1'-2 9/16" (370)	1'-2 13/16" (376)	1'-3 1/32" (382)	1'-3 3/32" (383)	1'-3 5/16" (389)	
		ATAD2010	ATAD2110	ATAD2410	ATAD2610	ATAD2710	ATAD2810	ATAD2910	ATAD2910G*	ATAD21010	
		23 1/4" (592)	2'-1 29/32" (655)	2'-2 17/32" (674)	2'-3 1/16" (687)	2'-2 9/16" (674)	2'-2 13/16" (681)	2'-3 1/32" (687)	2'-3 3/32" (688)	2'-3 5/16" (694)	
		ATAD2020	ATAD2120	ATAD2420	ATAD2620	ATAD2720	ATAD2820	ATAD2920	ATAD2920G*	ATAD21020	
		27 1/4" (692)	2'-5 29/32" (756)	2'-6 17/32" (775)	2'-7 1/16" (789)	2'-6 9/16" (776)	2'-6 13/16" (783)	2'-7 1/32" (788)	2'-7 3/32" (790)	2'-7 5/16" (795)	
		ATAD2024	ATAD2124	ATAD2424	ATAD2624	ATAD2724	ATAD2824	ATAD2924	ATAD2924G*	ATAD21024	
		31 1/4" (794)	2'-9 25/32" (858)	2'-10 17/32" (877)	2'-11 1/16" (890)	2'-10 9/16" (878)	2'-10 13/16" (884)	2'-11 1/32" (890)	2'-11 3/32" (891)	2'-11 5/16" (897)	
		ATAD2028	ATAD2128	ATAD2428	ATAD2628	ATAD2728	ATAD2828	ATAD2928	ATAD2928G*	ATAD21028	
		35 1/4" (895)	3'-1 29/32" (960)	3'-2 17/32" (978)	3'-3 1/16" (992)	3'-2 9/16" (979)	3'-2 13/16" (986)	3'-3 1/32" (991)	3'-3 3/32" (993)	3'-3 5/16" (999)	
		ATAD2030	ATAD2130	ATAD2430	ATAD2630	ATAD2730	ATAD2830	ATAD2930	ATAD2930G*	ATAD21030	
		39 1/4" (997)		3'-6 17/32" (1080)	3'-7 1/16" (1094)		3'-6 13/16" (1088)			3'-7 5/16" (1100)	
		ATAD2034		ATAD2434	ATAD2634		ATAD2834			ATAD21034	
		43 1/4" (1099)		3'-10 17/32" (1182)	3'-11 1/16" (1195)		3'-10 13/16" (1189)			3'-11 5/16" (1202)	
		ATAD2038		ATAD2438	ATAD2638		ATAD2838			ATAD21038	
		47 1/4" (1200)		4'-2 17/32" (1283)	4'-3 1/16" (1297)		4'-2 13/16" (1291)			4'-3 5/16" (1303)	
		ATAD2040		ATAD2440	ATAD2640		ATAD2840			ATAD21040	
		51 1/4" (1302)		4'-6 17/32" (1385)	4'-7 1/16" (1398)		4'-6 13/16" (1392)			4'-7 5/16" (1405)	
		ATAD2044		ATAD2444	ATAD2644		ATAD2844			ATAD21044	
		55 1/4" (1403)		4'-10 17/32" (1486)	4'-11 1/16" (1500)		4'-10 13/16" (1494)			4'-11 5/16" (1507)	
		ATAD2048		ATAD2448	ATAD2648		ATAD2848			ATAD21048	

*"Window Dimension" always refers to outside frame-to-frame dimension.
 *"Minimum Rough Opening" dimensions may need to be increased to allow for use of building wraps, flashing, sill panning, brackets, fasteners or other items. See pages 226-227 for more details.
 *Dimensions in parentheses are in millimeters.
 *Sized to fit over a stationary A-Series gliding patio door.

Notes on page 85 also apply to this page.

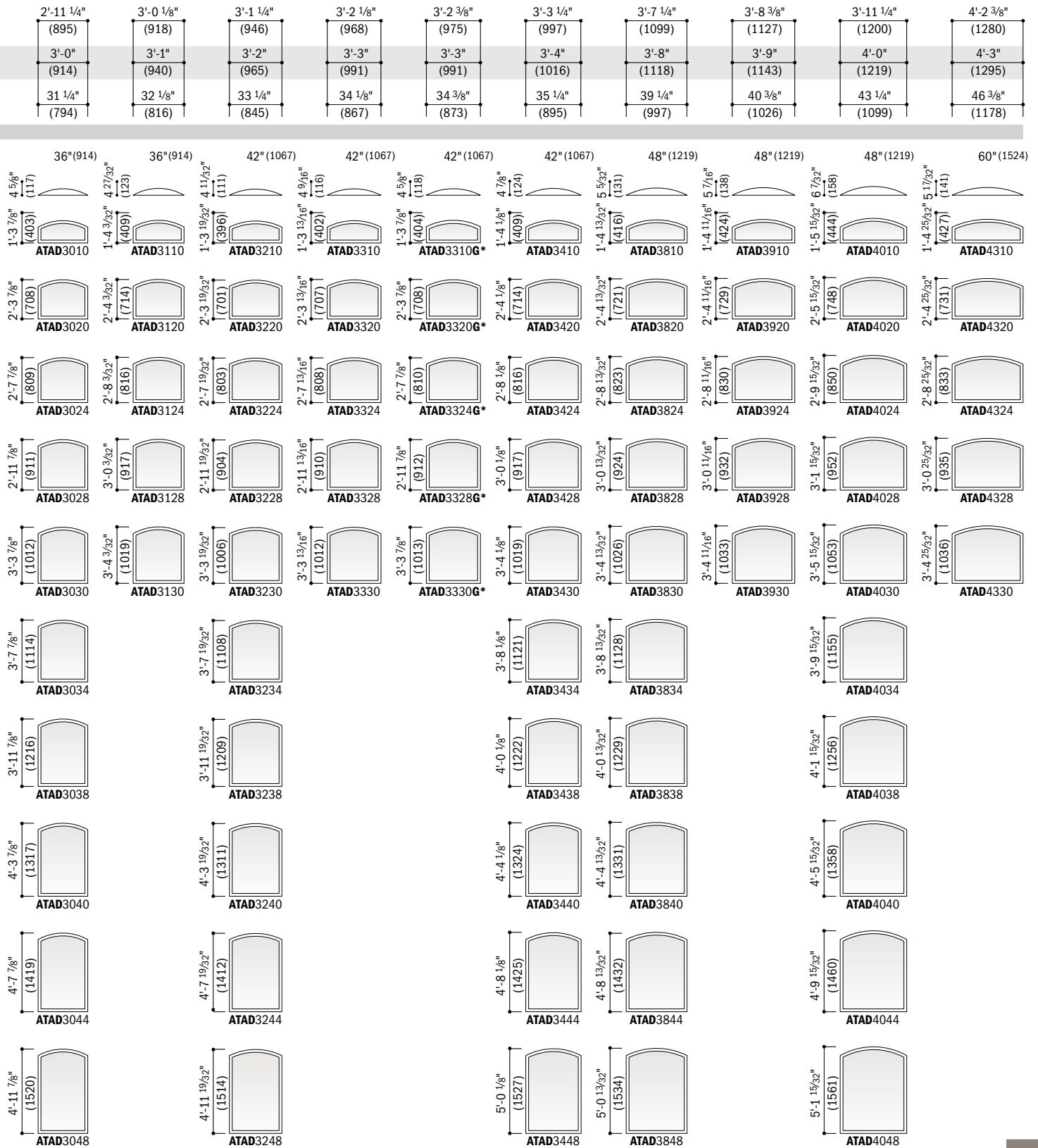

continued on next page

*"Window Dimension" always refers to outside frame-to-frame dimension.
 **"Minimum Rough Opening" dimensions may need to be increased to allow for use of building wraps, flashing, sill panning, brackets, fasteners or other items. See pages 226-227 for more details.
 • Dimensions in parentheses are in millimeters.
 *Sized to fit over a stationary A-Series gliding patio door.

SPECIALTY WINDOWS

Table of Direct-Set Arch Window Sizes (continued)

Notes on page 85 also apply to this page.

Scale 1/8" (3) = 1'-0" (305) – 1:96

Window Dimension	1'-11 1/4" (591)	2'-0 1/8" (613)	2'-3 1/4" (692)	2'-5 1/4" (743)	2'-6 1/8" (765)	2'-7 1/4" (794)	2'-8 1/8" (816)	2'-8 3/8" (822)	2'-9 1/4" (845)
Minimum Rough Opening	2'-0" (610)	2'-1" (635)	2'-4" (711)	2'-6" (762)	2'-7" (787)	2'-8" (813)	2'-9" (838)	2'-9" (838)	2'-10" (864)
Unobstructed Glass	19 1/4" (489)	20 1/8" (511)	23 1/4" (591)	25 1/4" (641)	26 1/8" (664)	27 1/4" (692)	28 1/8" (714)	28 3/8" (721)	29 1/4" (743)

CUSTOM SIZES AVAILABLE

Minimum Rough Opening = window height + 3/4" (19)

Unobstructed Glass = window height - 4" (102)

CUSTOM SIZES AVAILABLE

Window height shown in table	Radius	Chord Height	Shoulder Height	ATAD Model
24" (610)	24" (610)	3" (76)	59 1/4" (1505)	ATAD2050
30" (762)	30" (762)	2 17/32" (64)	5'-2 17/32" (1588)	ATAD2450
30" (762)	30" (762)	3 9/32" (83)	5'-2 17/32" (1588)	ATAD2450
30" (762)	30" (762)	3 13/16" (97)	5'-3 1/16" (1602)	ATAD2650
36" (914)	36" (914)	3 5/16" (84)	5'-3 1/16" (1602)	ATAD2650
36" (914)	36" (914)	3 9/16" (91)	5'-2 13/16" (1596)	ATAD2850
36" (914)	36" (914)	3 25/32" (96)	5'-2 13/16" (1596)	ATAD2850
36" (914)	36" (914)	3 27/32" (98)	5'-2 13/16" (1596)	ATAD2850
36" (914)	36" (914)	4 1/16" (103)	5'-3 5/16" (1608)	ATAD21050
63 1/4" (1607)			5'-6 1/4" (1683)	ATAD2054
63 1/4" (1607)			5'-6 17/32" (1690)	ATAD2454
63 1/4" (1607)			5'-7 1/16" (1703)	ATAD2654
63 1/4" (1607)			5'-6 13/16" (1697)	ATAD2854
63 1/4" (1607)			5'-7 5/16" (1710)	ATAD21054
67 1/4" (1708)			5'-10 1/4" (1784)	ATAD2058
67 1/4" (1708)			5'-10 17/32" (1791)	ATAD2458
67 1/4" (1708)			5'-11 1/16" (1805)	ATAD2658
67 1/4" (1708)			5'-10 13/16" (1799)	ATAD2858
67 1/4" (1708)			5'-11 5/16" (1811)	ATAD21058
71 1/4" (1810)			6'-2 17/32" (1893)	ATAD2460
71 1/4" (1810)			6'-2 1/4" (1886)	ATAD2060
71 1/4" (1810)			6'-3 1/16" (1906)	ATAD2660
71 1/4" (1810)			6'-2 13/16" (1900)	ATAD2860
71 1/4" (1810)			6'-3 5/16" (1913)	ATAD21060
75 1/4" (1911)			6'-6 17/32" (1994)	ATAD2464
75 1/4" (1911)			6'-6 1/4" (1988)	ATAD2064
75 1/4" (1911)			6'-7 1/16" (2008)	ATAD2664
75 1/4" (1911)			6'-6 13/16" (2002)	ATAD2864
75 1/4" (1911)			6'-7 5/16" (2015)	ATAD21064
79 1/4" (2013)			6'-10 17/32" (2096)	ATAD2468
79 1/4" (2013)			6'-10 1/4" (2089)	ATAD2068
79 1/4" (2013)			6'-11 1/16" (2110)	ATAD2668
79 1/4" (2013)			6'-10 13/16" (2104)	ATAD2868
79 1/4" (2013)			6'-11 5/16" (2116)	ATAD21068
87 1/4" (2216)			7'-6 17/32" (2299)	ATAD2474
87 1/4" (2216)			7'-6 1/4" (2292)	ATAD2074
87 1/4" (2216)			7'-7 1/16" (2313)	ATAD2674
87 1/4" (2216)			7'-6 13/16" (2307)	ATAD2874
87 1/4" (2216)			7'-7 5/16" (2319)	ATAD21074

• "Window Dimension" always refers to outside frame-to-frame dimension.
 • "Minimum Rough Opening" dimensions may need to be increased to allow for use of building wraps, flashing, sill panning, brackets, fasteners or other items. See pages 226-227 for more details.
 • Dimensions in parentheses are in millimeters.

Notes on page 85 also apply to this page.

2'-11 1/4" (895)	3'-0 1/8" (918)	3'-1 1/4" (946)	3'-2 1/8" (968)	3'-2 3/8" (975)	3'-3 1/4" (997)	3'-7 1/4" (1099)	3'-8 3/8" (1127)	3'-11 1/4" (1200)	4'-2 3/8" (1280)
3'-0" (914)	3'-1" (940)	3'-2" (965)	3'-3" (991)	3'-3" (991)	3'-4" (1016)	3'-8" (1118)	3'-9" (1143)	4'-0" (1219)	4'-3" (1295)
31 1/4" (794)	32 1/8" (816)	33 1/4" (845)	34 1/8" (867)	34 3/8" (873)	35 1/4" (895)	39 1/4" (997)	40 3/8" (1026)	43 1/4" (1099)	46 3/8" (1178)

36" (914)	36" (914)	42" (1067)	42" (1067)	42" (1067)	42" (1067)	48" (1219)	48" (1219)	48" (1219)	60" (1524)
4 5/8" (117)	4 27/32" (123)	4 11/32" (111)	4 9/16" (116)	4 5/8" (118)	4 7/8" (124)	5 5/32" (131)	5 7/16" (138)	6 7/32" (168)	5 17/32" (141)
5'-3 7/8" (1622)	5'-3 19/32" (1616)	5'-4 1/8" (1629)	5'-4 13/32" (1636)	5'-4 1/8" (1629)	5'-4 1/8" (1629)	5'-4 13/32" (1636)	5'-4 13/32" (1636)	5'-5 15/32" (1663)	5'-5 15/32" (1663)
ATAD3050	ATAD3250	ATAD3450	ATAD3850	ATAD3450	ATAD3850	ATAD4050	ATAD4050	ATAD4050	ATAD4050
5'-7 7/8" (1724)	5'-7 19/32" (1717)	5'-8 1/8" (1730)	5'-8 13/32" (1737)	5'-8 1/8" (1730)	5'-8 13/32" (1737)	5'-9 15/32" (1764)	5'-9 15/32" (1764)	5'-9 15/32" (1764)	5'-9 15/32" (1764)
ATAD3054	ATAD3254	ATAD3454	ATAD3854	ATAD3454	ATAD3854	ATAD4054	ATAD4054	ATAD4054	ATAD4054
5'-11 7/8" (1825)	5'-11 19/32" (1819)	6'-0 1/8" (1832)	6'-0 13/32" (1839)	6'-0 1/8" (1832)	6'-0 13/32" (1839)	6'-1 15/32" (1866)	6'-1 15/32" (1866)	6'-1 15/32" (1866)	6'-1 15/32" (1866)
ATAD3058	ATAD3258	ATAD3458	ATAD3858	ATAD3458	ATAD3858	ATAD4058	ATAD4058	ATAD4058	ATAD4058
6'-3 7/8" (1927)	6'-3 19/32" (1920)	6'-4 1/8" (1933)	6'-4 13/32" (1940)	6'-4 1/8" (1933)	6'-4 13/32" (1940)	6'-5 15/32" (1968)	6'-5 15/32" (1968)	6'-5 15/32" (1968)	6'-5 15/32" (1968)
ATAD3060	ATAD3260	ATAD3460	ATAD3860	ATAD3460	ATAD3860	ATAD4060	ATAD4060	ATAD4060	ATAD4060
6'-7 7/8" (2028)	6'-7 19/32" (2022)	6'-8 1/8" (2035)	6'-8 13/32" (2042)	6'-8 1/8" (2035)	6'-8 13/32" (2042)	6'-9 15/32" (2069)	6'-9 15/32" (2069)	6'-9 15/32" (2069)	6'-9 15/32" (2069)
ATAD3064	ATAD3264	ATAD3464	ATAD3864	ATAD3464	ATAD3864	ATAD4064	ATAD4064	ATAD4064	ATAD4064
6'-11 7/8" (2130)	6'-11 19/32" (2124)	7'-0 1/8" (2137)	7'-0 13/32" (2144)	7'-0 1/8" (2137)	7'-0 13/32" (2144)	7'-1 15/32" (2171)	7'-1 15/32" (2171)	7'-1 15/32" (2171)	7'-1 15/32" (2171)
ATAD3068	ATAD3268	ATAD3468	ATAD3868	ATAD3468	ATAD3868	ATAD4068	ATAD4068	ATAD4068	ATAD4068
7'-7 7/8" (2333)	7'-7 19/32" (2327)	7'-8 1/8" (2340)	7'-8 13/32" (2347)	7'-8 1/8" (2340)	7'-8 13/32" (2347)	7'-9 15/32" (2374)	7'-9 15/32" (2374)	7'-9 15/32" (2374)	7'-9 15/32" (2374)
ATAD3074	ATAD3274	ATAD3474	ATAD3874	ATAD3474	ATAD3874	ATAD4074	ATAD4074	ATAD4074	ATAD4074

continued on next page

- "Window Dimension" always refers to outside frame-to-frame dimension.
- "Minimum Rough Opening" dimensions may need to be increased to allow for use of building wraps, flashing, sill panning, brackets, fasteners or other items. See pages 226-227 for more details.
- Dimensions in parentheses are in millimeters.

SPECIALTY WINDOWS

Table of Direct-Set Arch Window Sizes (continued)

Notes on page 85 also apply to this page.

Scale 1/8" (3) = 1'-0" (305) – 1:96

Window Dimension	1'-11 1/4" (591)	2'-0 1/8" (613)	2'-3 1/4" (692)	2'-5 1/4" (743)	2'-6 1/8" (765)	2'-7 1/4" (794)	2'-8 1/8" (816)	2'-8 3/8" (822)	2'-9 1/4" (845)
Minimum Rough Opening	2'-0" (610)	2'-1" (635)	2'-4" (711)	2'-6" (762)	2'-7" (787)	2'-8" (813)	2'-9" (838)	2'-9" (838)	2'-10" (864)
Unobstructed Glass	19 1/4" (489)	20 1/8" (511)	23 1/4" (591)	25 1/4" (641)	26 1/8" (664)	27 1/4" (692)	28 1/8" (714)	28 3/8" (721)	29 1/4" (743)

CUSTOM SIZES AVAILABLE										
Window height shown in table	Radius	24" (610)	30" (762)	30" (762)	30" (762)	36" (914)	36" (914)	36" (914)	36" (914)	36" (914)
	Chord Height	3" (76)	2 17/32" (64)	3 9/32" (83)	3 13/16" (97)	3 5/16" (84)	3 9/16" (91)	3 25/32" (96)	3 27/32" (98)	4 1/16" (103)
	Shoulder Height	95 1/4" (2419)	8'-2 1/4" (2496)	8'-2 17/32" (2502)	8'-3 1/16" (2516)	8'-2 13/16" (2510)				8'-3 5/16" (2523)
	Window Model	ATAD2080		ATAD2480	ATAD2680	ATAD2880				ATAD21080

Minimum Rough Opening = window height + 3/4" (19)
Unobstructed Glass = window height - 4" (102)

Direct-Set Arch Window Area Specifications

Window Number	Glass Area Sq. Ft./ (m ²)	Window Number	Glass Area Sq. Ft./ (m ²)	Window Number	Glass Area Sq. Ft./ (m ²)	Window Number	Glass Area Sq. Ft./ (m ²)
ATAD2010	1.27 (0.12)	ATAD2464	11.90 (1.11)	ATAD2850	10.95 (1.02)	ATAD3020	4.91 (0.46)
ATAD2020	2.88 (0.27)	ATAD2468	12.54 (1.17)	ATAD2854	11.71 (1.09)	ATAD3024	5.78 (0.54)
ATAD2024	3.41 (0.32)	ATAD2474	13.84 (1.29)	ATAD2858	12.47 (1.16)	ATAD3028	6.65 (0.62)
ATAD2028	3.95 (0.37)	ATAD2480	15.13 (1.41)	ATAD2860	13.22 (1.23)	ATAD3030	7.51 (0.70)
ATAD2030	4.48 (0.42)	ATAD2610	1.77 (0.16)	ATAD2864	13.98 (1.30)	ATAD3034	8.38 (0.78)
ATAD2034	5.02 (0.47)	ATAD2620	3.87 (0.36)	ATAD2868	14.74 (1.37)	ATAD3038	9.25 (0.86)
ATAD2038	5.55 (0.52)	ATAD2624	4.57 (0.42)	ATAD2874	16.25 (1.51)	ATAD3040	10.12 (0.94)
ATAD2040	6.09 (0.57)	ATAD2628	5.27 (0.49)	ATAD2880	17.77 (1.65)	ATAD3044	10.99 (1.02)
ATAD2044	6.62 (0.62)	ATAD2630	5.98 (0.56)	ATAD2910	1.96 (0.18)	ATAD3048	11.85 (1.10)
ATAD2048	7.16 (0.66)	ATAD2634	6.68 (0.62)	ATAD2920	4.30 (0.40)	ATAD3050	12.72 (1.18)
ATAD2050	7.69 (0.71)	ATAD2638	7.38 (0.69)	ATAD2924	5.09 (0.47)	ATAD3054	13.59 (1.26)
ATAD2054	8.23 (0.76)	ATAD2640	8.08 (0.75)	ATAD2928	5.87 (0.54)	ATAD3058	14.46 (1.34)
ATAD2058	8.76 (0.81)	ATAD2644	8.78 (0.82)	ATAD2930	6.65 (0.62)	ATAD3060	15.33 (1.42)
ATAD2060	9.29 (0.86)	ATAD2648	9.48 (0.88)	ATAD2910G	1.99 (0.18)	ATAD3064	16.19 (1.50)
ATAD2064	9.83 (0.91)	ATAD2650	10.18 (0.95)	ATAD2920G	4.35 (0.40)	ATAD3068	17.06 (1.59)
ATAD2068	10.36 (0.96)	ATAD2654	10.88 (1.01)	ATAD2924G	5.14 (0.48)	ATAD3074	18.80 (1.75)
ATAD2074	11.43 (1.06)	ATAD2658	11.59 (1.08)	ATAD2928G	5.93 (0.55)	ATAD3080	20.53 (1.91)
ATAD2080	12.50 (1.16)	ATAD2660	12.29 (1.14)	ATAD2930G	6.72 (0.62)	ATAD3110	2.41 (0.22)
ATAD2110	1.28 (0.12)	ATAD2664	12.99 (1.21)	ATAD21010	2.08 (0.19)	ATAD3120	5.09 (0.47)
ATAD2120	2.96 (0.27)	ATAD2668	13.69 (1.27)	ATAD21020	4.52 (0.42)	ATAD3124	5.98 (0.56)
ATAD2124	3.52 (0.33)	ATAD2674	15.09 (1.40)	ATAD21024	5.33 (0.50)	ATAD3128	6.87 (0.64)
ATAD2128	4.08 (0.38)	ATAD2680	16.50 (1.53)	ATAD21028	6.14 (0.57)	ATAD3130	7.76 (0.72)
ATAD2130	4.64 (0.43)	ATAD2710	1.76 (0.16)	ATAD21030	6.95 (0.65)	ATAD3210	2.41 (0.22)
ATAD2410	1.57 (0.15)	ATAD2720	3.94 (0.37)	ATAD21034	7.77 (0.72)	ATAD3220	5.18 (0.48)
ATAD2420	3.50 (0.33)	ATAD2724	4.66 (0.43)	ATAD21038	8.58 (0.80)	ATAD3224	6.10 (0.57)
ATAD2424	4.15 (0.39)	ATAD2728	5.39 (0.50)	ATAD21040	9.39 (0.87)	ATAD3228	7.02 (0.65)
ATAD2428	4.79 (0.45)	ATAD2730	6.11 (0.57)	ATAD21044	10.20 (0.95)	ATAD3230	7.95 (0.74)
ATAD2430	5.44 (0.51)	ATAD2810	1.87 (0.17)	ATAD21048	11.02 (1.02)	ATAD3234	8.87 (0.82)
ATAD2434	6.09 (0.57)	ATAD2820	4.14 (0.38)	ATAD21050	11.83 (1.10)	ATAD3238	9.80 (0.91)
ATAD2438	6.73 (0.63)	ATAD2824	4.90 (0.46)	ATAD21054	12.64 (1.17)	ATAD3240	10.72 (1.00)
ATAD2440	7.38 (0.69)	ATAD2828	5.66 (0.53)	ATAD21058	13.45 (1.25)	ATAD3244	11.64 (1.08)
ATAD2444	8.02 (0.75)	ATAD2830	6.41 (0.60)	ATAD21060	14.27 (1.33)	ATAD3248	12.57 (1.17)
ATAD2448	8.67 (0.81)	ATAD2834	7.17 (0.67)	ATAD21064	15.08 (1.40)	ATAD3250	13.49 (1.25)
ATAD2450	9.32 (0.87)	ATAD2838	7.93 (0.74)	ATAD21068	15.89 (1.48)	ATAD3254	14.41 (1.34)
ATAD2454	9.96 (0.93)	ATAD2840	8.68 (0.81)	ATAD21074	17.52 (1.63)	ATAD3258	15.34 (1.42)
ATAD2458	10.61 (0.99)	ATAD2844	9.44 (0.88)	ATAD21080	19.14 (1.78)		
ATAD2460	11.25 (1.05)	ATAD2848	10.20 (0.95)	ATAD3010	2.31 (0.21)		

• Dimensions in parentheses are in square meters.

continued on next page

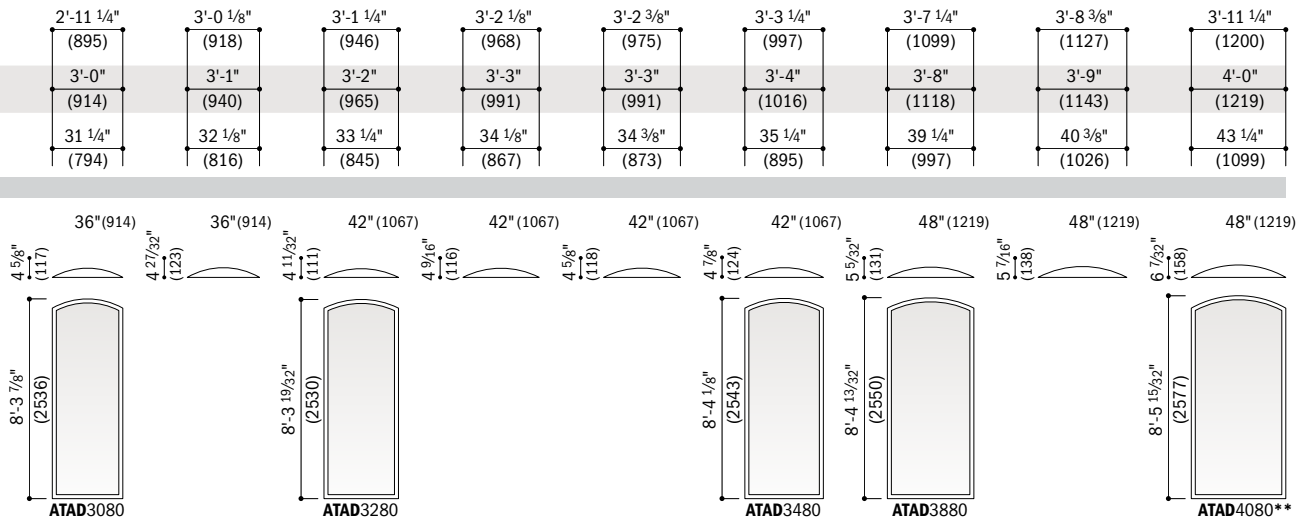

continued on next page

Direct-Set Arch Window Area Specifications *(continued)*

Window Number	Glass Area Sq. Ft./ (m ²)	Window Number	Glass Area Sq. Ft./ (m ²)	Window Number	Glass Area Sq. Ft./ (m ²)
ATAD3260	16.26 (1.51)	ATAD3830	9.53 (0.89)	ATAD4310	3.61 (0.34)
ATAD3264	17.18 (1.60)	ATAD3834	10.62 (0.99)	ATAD4320	7.47 (0.69)
ATAD3268	18.11 (1.68)	ATAD3838	11.71 (1.09)	ATAD4324	8.76 (0.81)
ATAD3274	19.95 (1.85)	ATAD3840	12.80 (1.19)	ATAD4328	10.05 (0.93)
ATAD3280	21.80 (2.03)	ATAD3844	13.89 (1.29)	ATAD4330	11.34 (1.05)
ATAD3310	2.51 (0.23)	ATAD3848	14.98 (1.39)	ATAD4410	3.72 (0.35)
ATAD3320	5.35 (0.50)	ATAD3850	16.07 (1.49)	ATAD4420	7.66 (0.71)
ATAD3324	6.30 (0.59)	ATAD3854	17.16 (1.59)	ATAD4424	8.97 (0.83)
ATAD3328	7.25 (0.67)	ATAD3858	18.25 (1.70)	ATAD4428	10.29 (0.96)
ATAD3330	8.19 (0.76)	ATAD3860	19.34 (1.80)	ATAD4430	11.60 (1.08)
ATAD3310G	2.54 (0.24)	ATAD3864	20.43 (1.90)	ATAD4434	12.91 (1.20)
ATAD3320G	5.40 (0.50)	ATAD3868	21.52 (2.00)	ATAD4438	14.22 (1.32)
ATAD3324G	6.35 (0.59)	ATAD3874	23.70 (2.20)	ATAD4440	15.54 (1.44)
ATAD3328G	7.31 (0.68)	ATAD3880	25.88 (2.40)	ATAD4444	16.85 (1.57)
ATAD3330G	8.26 (0.77)	ATAD3910	3.13 (0.29)	ATAD4448	18.16 (1.69)
ATAD3410	2.64 (0.25)	ATAD3920	6.49 (0.60)	ATAD4450	19.47 (1.81)
ATAD3420	5.58 (0.52)	ATAD3924	7.62 (0.71)	ATAD4454	20.79 (1.93)
ATAD3424	6.56 (0.61)	ATAD3928	8.74 (0.81)	ATAD4458	22.10 (2.05)
ATAD3428	7.54 (0.70)	ATAD3930	9.86 (0.92)	ATAD4460	23.41 (2.17)
ATAD3430	8.51 (0.79)	ATAD4010	3.52 (0.33)	ATAD4464	24.72 (2.30)
ATAD3434	9.49 (0.88)	ATAD4020	7.12 (0.66)	ATAD4468	26.04 (2.42)
ATAD3438	10.47 (0.97)	ATAD4024	8.32 (0.77)	ATAD4474	28.66 (2.66)
ATAD3440	11.45 (1.06)	ATAD4028	9.52 (0.88)	ATAD4480	31.29 (2.91)
ATAD3444	12.43 (1.15)	ATAD4030	10.73 (1.00)	ATAD4810	4.29 (0.40)
ATAD3448	13.41 (1.25)	ATAD4034	11.93 (1.11)	ATAD4820	8.56 (0.79)
ATAD3450	14.39 (1.34)	ATAD4038	13.13 (1.22)	ATAD4824	9.98 (0.93)
ATAD3454	15.37 (1.43)	ATAD4040	14.33 (1.33)	ATAD4828	11.40 (1.06)
ATAD3458	16.35 (1.52)	ATAD4044	15.53 (1.44)	ATAD4830	12.83 (1.19)
ATAD3460	17.33 (1.61)	ATAD4048	16.73 (1.55)	ATAD4834	14.25 (1.32)
ATAD3464	18.31 (1.70)	ATAD4050	17.93 (1.67)	ATAD4838	15.67 (1.46)
ATAD3468	19.29 (1.79)	ATAD4054	19.14 (1.78)	ATAD4840	17.10 (1.59)
ATAD3474	21.24 (1.97)	ATAD4058	20.34 (1.89)	ATAD4844	18.52 (1.72)
ATAD3480	23.20 (2.16)	ATAD4060	21.54 (2.00)	ATAD4848	19.95 (1.85)
ATAD3810	2.99 (0.28)	ATAD4064	22.74 (2.11)	ATAD4850	21.37 (1.99)
ATAD3820	6.26 (0.58)	ATAD4068	23.94 (2.22)	ATAD4854	22.79 (2.12)
ATAD3824	7.35 (0.68)	ATAD4074	26.34 (2.45)		
ATAD3828	8.44 (0.78)	ATAD4080	28.75 (2.67)		

*Dimensions in parentheses are in square meters.

continued on page 90



Custom-size windows are available in 1/8" (3) increments. Contact your Andersen supplier for more information.

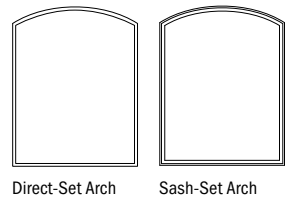

Direct-set arch (ATAD) window sizes shown. Use window dimensions and minimum rough opening formula shown for sash-set arch (ATA) window sizes. For sash-set unobstructed glass dimensions, see pages 94-97. All sizes shown, along with custom sizes, are available with PG upgrade.

Grille patterns shown on page 105. Details shown on page 111.

- *"Window Dimension" always refers to outside frame to frame dimension.
- *"Minimum Rough Opening" dimensions may need to be increased to allow for use of building wraps, flashing, sill panning, brackets, fasteners or other items. See pages 226-227 for more details.
- Dimensions in parentheses are in millimeters.
- **Tempered glass required. Some visual distortion may occur.

SPECIALTY WINDOWS

Table of Direct-Set Arch Window Sizes (continued)

Notes on page 89 also apply to this page.

Scale 1/8" (3) = 1'-0" (305) – 1:96

Window Dimension	4'-3 1/4" (1302)	4'-7 1/4" (1403)	4'-11 1/4" (1505)	5'-3 1/4" (1607)	5'-7 1/4" (1708)	5'-11 1/4" (1810)
Minimum Rough Opening	4'-4" (1321)	4'-8" (1422)	5'-0" (1524)	5'-4" (1626)	5'-8" (1727)	6'-0" (1829)
Unobstructed Glass	47 1/4" (1200)	51 1/4" (1302)	55 1/4" (1403)	59 1/4" (1505)	63 1/4" (1607)	67 1/4" (1708)

CUSTOM SIZES AVAILABLE

Minimum Rough Opening = window height + 3/4" (19)

Unobstructed Glass = window height - 4" (102)

CUSTOM SIZES AVAILABLE

Window height shown in table	Radius	60" (1524)	60" (1524)	60" (1524)	72" (1829)	72" (1829)	72" (1829)
	Chord Height	5 3/4" (146)	6 3/4" (171)	7 13/16" (199)	7 9/16" (186)	8 11/32" (212)	9 7/16" (240)
	Shoulder Height	11 1/4" (286)	1'-6" (457)	1'-7 1/16" (484)	1'-6 9/16" (472)	1'-7 19/32" (497)	1'-8 11/16" (525)
		23 1/4" (591)	2'-5" (737)	2'-7 1/16" (789)	2'-6 9/16" (776)	2'-7 19/32" (802)	2'-8 11/16" (830)
		27 1/4" (692)	2'-10" (863)	2'-11 1/16" (891)	2'-10 9/16" (878)	2'-11 19/32" (904)	3'-0 11/16" (932)
		31 1/4" (794)	3'-2" (965)	3'-3 1/16" (992)	3'-2 9/16" (980)	3'-3 19/32" (1005)	3'-4 11/16" (1033)
		35 1/4" (895)	3'-6" (1066)	3'-7 1/16" (1094)	3'-6 9/16" (1081)	3'-7 19/32" (1107)	3'-8 11/16" (1135)
		39 1/4" (997)	3'-10" (1168)	3'-11 1/16" (1196)	3'-10 9/16" (1183)	3'-11 19/32" (1209)	4'-0 11/16" (1237)
		43 1/4" (1099)	4'-2" (1270)	4'-3 1/16" (1297)	4'-2 9/16" (1284)	4'-3 19/32" (1310)	4'-4 11/16" (1338)
		47 1/4" (1200)	4'-6" (1371)	4'-7 1/16" (1399)	4'-6 9/16" (1386)	4'-7 19/32" (1412)	4'-8 11/16" (1440)
		51 1/4" (1302)	4'-10" (1473)	4'-11 1/16" (1500)	4'-10 9/16" (1488)	4'-11 19/32" (1513)	5'-0 11/16" (1541)
		55 1/4" (1403)	5'-2" (1574)	5'-3 1/16" (1602)	5'-2 9/16" (1589)	5'-3 19/32" (1615)	5'-4 11/16" (1643)
		ATAD4410	ATAD4810	ATAD5010	ATAD5410	ATAD5810	ATAD6010
		ATAD4420	ATAD4820	ATAD5020	ATAD5420	ATAD5820	ATAD6020
		ATAD4424	ATAD4824	ATAD5024	ATAD5424	ATAD5824	ATAD6024
		ATAD4428	ATAD4828	ATAD5028	ATAD5428	ATAD5828	ATAD6028
		ATAD4430	ATAD4830	ATAD5030	ATAD5430	ATAD5830	ATAD6030
		ATAD4434	ATAD4834	ATAD5034	ATAD5434	ATAD5834	ATAD6034
		ATAD4438	ATAD4838	ATAD5038	ATAD5438	ATAD5838	ATAD6038
		ATAD4440	ATAD4840	ATAD5040	ATAD5440	ATAD5840	ATAD6040
		ATAD4444	ATAD4844	ATAD5044	ATAD5444	ATAD5844	ATAD6044
		ATAD4448	ATAD4848	ATAD5048	ATAD5448	ATAD5848	ATAD6048

* "Window Dimension" always refers to outside frame-to-frame dimension.
 * "Minimum Rough Opening" dimensions may need to be increased to allow for use of building wraps, flashing, sill panning, brackets, fasteners or other items. See pages 226-227 for more details.
 * Dimensions in parentheses are in millimeters.

Notes on page 89 also apply to this page.

6'-3 1/4" (1911)	6'-7 1/4" (2013)	6'-11 1/4" (2115)	7'-3 1/4" (2216)	7'-10 7/16" (2399)	7'-11 1/4" (2419)
6'-4" (1930)	6'-8" (2032)	7'-0" (2134)	7'-4" (2235)	7'-11" (2413)	8'-0" (2438)
71 1/4" (1810)	75 1/4" (1911)	79 1/4" (2013)	83 1/4" (2115)	90 7/16" (2297)	91 1/4" (2318)

84" (2134) 8 29/62" (226) 1'-8 5/32" (512) ATAD6410	84" (2134) 9 15/16" (252) 1'-9 3/16" (538) ATAD6810	84" (2134) 11 1/32" (280) 1'-10 9/32" (566) ATAD7010	96" (2438) 10 1/2" (266) 1'-9 3/4" (552) ATAD7410	96" (2438) 12 13/32" (315) 1'-11 21/32" (601) ATAD71110	96" (2438) 12 21/32" (321) 1'-11 29/32" (607) ATAD8010
2'-8 5/32" (817) ATAD6420	2'-9 3/16" (843) ATAD6820	2'-10 9/32" (871) ATAD7020	2'-9 3/4" (857) ATAD7420	2'-11 21/32" (906) ATAD71120	2'-11 29/32" (912) ATAD8020
3'-0 5/32" (918) ATAD6424	3'-1 3/16" (944) ATAD6824	3'-2 9/32" (973) ATAD7024	3'-1 3/4" (958) ATAD7424	3'-3 21/32" (1008) ATAD71124	3'-3 29/32" (1013) ATAD8024
3'-4 5/32" (1020) ATAD6428	3'-5 3/16" (1046) ATAD6828	3'-6 9/32" (1074) ATAD7028	3'-5 3/4" (1060) ATAD7428	3'-7 21/32" (1109) ATAD71128	3'-7 29/32" (1115) ATAD8028
3'-8 5/32" (1121) ATAD6430	3'-9 3/16" (1148) ATAD6830	3'-10 9/32" (1176) ATAD7030	3'-9 3/4" (1162) ATAD7430	3'-11 21/32" (1211) ATAD71130	3'-11 29/32" (1217) ATAD8030
4'-0 5/32" (1223) ATAD6434	4'-1 3/16" (1249) ATAD6834	4'-2 9/32" (1277) ATAD7034	4'-1 3/4" (1263) ATAD7434		4'-3 29/32" (1318) ATAD8034
4'-4 5/32" (1325) ATAD6438	4'-5 3/16" (1351) ATAD6838	4'-6 9/32" (1379) ATAD7038	4'-5 3/4" (1365) ATAD7438		4'-7 29/32" (1420) ATAD8038
4'-8 5/32" (1426) ATAD6440	4'-9 3/16" (1452) ATAD6840	4'-10 9/32" (1481) ATAD7040	4'-9 3/4" (1466) ATAD7440		4'-11 29/32" (1521) ATAD8040
5'-0 5/32" (1528) ATAD6444	5'-1 3/16" (1554) ATAD6844	5'-2 9/32" (1582) ATAD7044	5'-1 3/4" (1568) ATAD7444		5'-3 29/32" (1623) ATAD8044
5'-4 5/32" (1629) ATAD6448	5'-5 3/16" (1656) ATAD6848	5'-6 9/32" (1684) ATAD7048	5'-5 3/4" (1670) ATAD7448		5'-7 29/32" (1725) ATAD8048

continued on next page

- "Window Dimension" always refers to outside frame-to-frame dimension.
- "Minimum Rough Opening" dimensions may need to be increased to allow for use of building wraps, flashing, sill panning, brackets, fasteners or other items. See pages 226-227 for more details.
- Dimensions in parentheses are in millimeters.

SPECIALTY WINDOWS

Table of Direct-Set Arch Window Sizes (continued)

Scale 1/8" (3) = 1'-0" (305) – 1:96

Notes on page 89 also apply to this page.

Window Dimension	4'-3 1/4" (1302)	4'-7 1/4" (1403)	4'-11 1/4" (1505)	5'-3 1/4" (1607)	5'-7 1/4" (1708)	5'-11 1/4" (1810)
Minimum Rough Opening	4'-4" (1321)	4'-8" (1422)	5'-0" (1524)	5'-4" (1626)	5'-8" (1727)	6'-0" (1829)
Unobstructed Glass	47 1/4" (1200)	51 1/4" (1302)	55 1/4" (1403)	59 1/4" (1505)	63 1/4" (1607)	67 1/4" (1708)

CUSTOM SIZES AVAILABLE

Window height shown in table	Radius	60" (1524)	60" (1524)	60" (1524)	72" (1829)	72" (1829)	72" (1829)
	Chord Height	5 3/4" (146)	6 3/4" (171)	7 13/16" (199)	7 9/16" (186)	8 11/32" (212)	9 7/16" (240)
	Shoulder Height	59 1/4" (1505)	5'-6" (1676)	5'-7 1/16" (1704)	5'-6 9/16" (1691)	5'-7 19/32" (1717)	5'-8 11/16" (1745)
		ATAD4450	ATAD4850	ATAD5050	ATAD5450	ATAD5850	ATAD6050
		63 1/4" (1607)	5'-10" (1778)	5'-11 1/16" (1805)	5'-10 9/16" (1792)	5'-11 19/32" (1818)	6'-0 11/16" (1846)
		ATAD4454	ATAD4854	ATAD5054	ATAD5454	ATAD5854	ATAD6054
		67 1/4" (1708)	6'-2" (1879)	6'-3 1/16" (1907)	6'-2 9/16" (1894)	6'-3 19/32" (1920)	6'-4 11/16" (1948)
		ATAD4458	ATAD4858	ATAD5058	ATAD5458	ATAD5858	ATAD6058
		71 1/4" (1810)	6'-6" (1981)	6'-7 1/16" (2008)	6'-6 9/16" (1996)	6'-7 19/32" (2021)	6'-8 11/16" (2049)
		ATAD4460	ATAD4860	ATAD5060	ATAD5460	ATAD5860	ATAD6060
		75 1/4" (1911)	6'-10" (2082)	6'-11 1/16" (2110)	6'-10 9/16" (2097)	6'-11 19/32" (2123)	7'-0 11/16" (2151)
		ATAD4464	ATAD4864	ATAD5064	ATAD5464	ATAD5864	ATAD6064
		79 1/4" (2013)	7'-2" (2184)	7'-3 1/16" (2212)	7'-2 9/16" (2199)	7'-3 19/32" (2225)	7'-4 11/16" (2253)
		ATAD4468	ATAD4868	ATAD5068	ATAD5468	ATAD5868	ATAD6068
		87 1/4" (2216)	7'-10" (2387)	7'-11 1/16" (2415)	7'-10 9/16" (2402)	7'-11 19/32" (2428)	8'-0 11/16" (2456)
		ATAD4474	ATAD4874	ATAD5074	ATAD5474	ATAD5874	ATAD6074

• "Window Dimension" always refers to outside frame-to-frame dimension.
 • "Minimum Rough Opening" dimensions may need to be increased to allow for use of building wraps, flashing, sill panning, brackets, fasteners or other items. See pages 226-227 for more details.
 • Dimensions in parentheses are in millimeters.

6'-3 1/4" (1911)	6'-7 1/4" (2013)	6'-11 1/4" (2115)	7'-3 1/4" (2216)	7'-10 7/16" (2399)	7'-11 1/4" (2419)
6'-4" (1930)	6'-8" (2032)	7'-0" (2134)	7'-4" (2235)	7'-11" (2413)	8'-0" (2438)
71 1/4" (1810)	75 1/4" (1911)	79 1/4" (2013)	83 1/4" (2115)	90 7/16" (2297)	91 1/4" (2318)

 84" (2134) 8 29/32" (226) 5'-8 5/32" (1731) ATAD6450	 84" (2134) 9 15/16" (252) 5'-9 3/16" (1757) ATAD6850	 84" (2134) 11 1/32" (280) 5'-10 9/32" (1785) ATAD7050	 96" (2438) 10 1/2" (266) 5'-9 3/4" (1771) ATAD7450	 96" (2438) 12 13/32" (315) 5'-11 29/32" (1826) ATAD8050**
 6'-0 5/32" (1833) ATAD6454	 6'-1 3/16" (1859) ATAD6854	 6'-2 9/32" (1887) ATAD7054	 6'-1 3/4" (1873) ATAD7454	 6'-3 29/32" (1928) ATAD8054**
 6'-4 5/32" (1934) ATAD6458	 6'-5 3/16" (1960) ATAD6858	 6'-6 9/32" (1989) ATAD7058	 6'-5 3/4" (1974) ATAD7458**	 6'-7 29/32" (2029) ATAD8058**
 6'-8 5/32" (2036) ATAD6460	 6'-9 3/16" (2062) ATAD6860	 6'-10 9/32" (2090) ATAD7060**	 6'-9 3/4" (2076) ATAD7460**	 6'-11 29/32" (2131) ATAD8060**
 7'-0 5/32" (2137) ATAD6464	 7'-1 3/16" (2164) ATAD6864	 7'-2 9/32" (2192) ATAD7064**		continued on next page
 7'-4 5/32" (2239) ATAD6468	 7'-5 3/16" (2265) ATAD6868**	 7'-6 9/32" (2293) ATAD7068**	Custom-size windows are available in 1/8" (3) increments. Contact your Andersen supplier for more information.	
 8'-0 5/32" (2442) ATAD6474**	 8'-1 3/16" (2468) ATAD6874**	 8'-2 9/32" (2497) ATAD7074**	Direct-set arch (ATAD) window sizes shown. Use window dimensions and minimum rough opening formula shown for sash-set arch (ATA) window sizes. For sash-set unobstructed glass dimensions, see pages 94-97. All sizes shown, along with custom sizes, are available with PG upgrade.	 Direct-Set Arch
			Grille patterns shown on page 105. Details shown on page 111.	 Sash-Set Arch

• "Window Dimension" always refers to outside frame-to-frame dimension.
 • "Minimum Rough Opening" dimensions may need to be increased to allow for use of building wraps, flashing, sill panning, brackets, fasteners or other items. See pages 226-227 for more details.
 • Dimensions in parentheses are in millimeters.
 • **Tempered glass required. Some visual distortion may occur.

SPECIALTY WINDOWS

Table of Direct-Set Arch Window Sizes (continued)

Scale 1/8" (3) = 1'-0" (305) – 1:96

Notes on the next page also apply to this page.

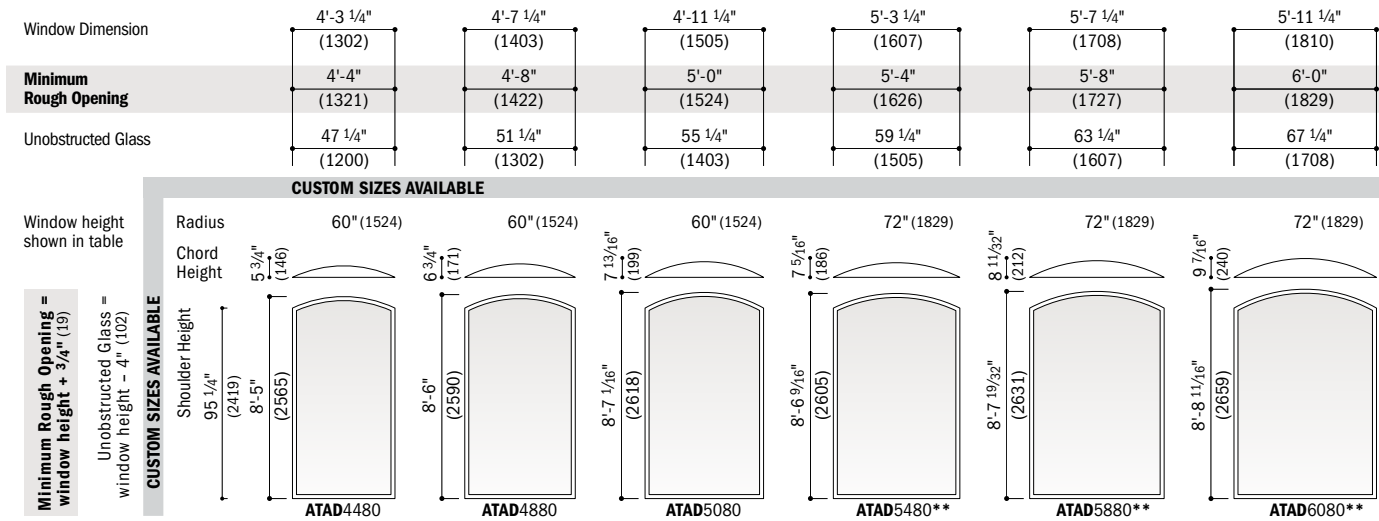

- * "Window Dimension" always refers to outside frame-to-frame dimension.
- ** "Minimum Rough Opening" dimensions may need to be increased to allow for use of building wraps, flashing, sill panning, brackets, fasteners or other items. See pages 226-227 for more details.
- Dimensions in parentheses are in millimeters.
- **Tempered glass required. Some visual distortion may occur.

Direct-Set Arch Window Area Specifications

(continued from page 85)

Window Number	Glass Area Sq. Ft./ (m ²)	Window Number	Glass Area Sq. Ft./ (m ²)	Window Number	Glass Area Sq. Ft./ (m ²)	Window Number	Glass Area Sq. Ft./ (m ²)
ATAD4858	24.22 (2.25)	ATAD5444	21.57 (2.00)	ATAD6030	17.69 (1.64)	ATAD6810	7.42 (0.69)
ATAD4860	25.64 (2.38)	ATAD5448	23.21 (2.16)	ATAD6034	19.56 (1.82)	ATAD6820	13.70 (1.27)
ATAD4864	27.06 (2.51)	ATAD5450	24.86 (2.31)	ATAD6038	21.43 (1.99)	ATAD6824	15.79 (1.47)
ATAD4868	28.49 (2.65)	ATAD5454	26.51 (2.46)	ATAD6040	23.30 (2.16)	ATAD6828	17.88 (1.66)
ATAD4874	31.33 (2.91)	ATAD5458	28.15 (2.62)	ATAD6044	25.17 (2.34)	ATAD6830	19.97 (1.85)
ATAD4880	34.18 (3.18)	ATAD5460	29.80 (2.77)	ATAD6048	27.03 (2.51)	ATAD6834	22.06 (2.05)
ATAD5010	4.91 (0.46)	ATAD5464	31.44 (2.92)	ATAD6050	28.90 (2.69)	ATAD6838	24.15 (2.24)
ATAD5020	9.52 (0.88)	ATAD5468	33.09 (3.07)	ATAD6054	30.77 (2.86)	ATAD6840	26.24 (2.44)
ATAD5024	11.05 (1.03)	ATAD5474	36.38 (3.38)	ATAD6058	32.64 (3.03)	ATAD6844	28.33 (2.63)
ATAD5028	12.58 (1.17)	ATAD5480	39.67 (3.69)	ATAD6060	34.51 (3.21)	ATAD6848	30.42 (2.83)
ATAD5030	14.12 (1.31)	ATAD5810	5.76 (0.54)	ATAD6064	36.37 (3.38)	ATAD6850	32.51 (3.02)
ATAD5034	15.65 (1.45)	ATAD5820	11.04 (1.03)	ATAD6068	38.24 (3.55)	ATAD6854	34.60 (3.21)
ATAD5038	17.19 (1.60)	ATAD5824	12.79 (1.19)	ATAD6074	41.98 (3.90)	ATAD6858	36.69 (3.41)
ATAD5040	18.72 (1.74)	ATAD5828	14.55 (1.35)	ATAD6080	45.71 (4.25)	ATAD6860	38.78 (3.60)
ATAD5044	20.26 (1.88)	ATAD5830	16.31 (1.51)	ATAD6410	6.67 (0.62)	ATAD6864	40.87 (3.80)
ATAD5048	21.79 (2.02)	ATAD5834	18.06 (1.68)	ATAD6420	12.61 (1.17)	ATAD6868	42.96 (3.99)
ATAD5050	23.33 (2.17)	ATAD5838	19.82 (1.84)	ATAD6424	14.59 (1.36)	ATAD6874	47.14 (4.38)
ATAD5054	24.86 (2.31)	ATAD5840	21.58 (2.00)	ATAD6428	16.57 (1.54)	ATAD6880	51.32 (4.77)
ATAD5058	26.40 (2.45)	ATAD5844	23.33 (2.17)	ATAD6430	18.55 (1.72)	ATAD7010	8.24 (0.77)
ATAD5060	27.93 (2.59)	ATAD5848	25.09 (2.33)	ATAD6434	20.53 (1.91)	ATAD7020	14.85 (1.38)
ATAD5064	29.47 (2.74)	ATAD5850	26.85 (2.49)	ATAD6438	22.51 (2.09)	ATAD7024	17.05 (1.58)
ATAD5068	31.00 (2.88)	ATAD5854	28.60 (2.66)	ATAD6440	24.49 (2.27)	ATAD7028	19.25 (1.79)
ATAD5074	34.07 (3.17)	ATAD5858	30.36 (2.82)	ATAD6444	26.47 (2.46)	ATAD7030	21.45 (1.99)
ATAD5080	37.14 (3.45)	ATAD5860	32.12 (2.98)	ATAD6448	28.45 (2.64)	ATAD7034	23.65 (2.20)
ATAD5410	5.11 (0.47)	ATAD5864	33.88 (3.15)	ATAD6450	30.42 (2.83)	ATAD7038	25.85 (2.40)
ATAD5420	10.05 (0.93)	ATAD5868	35.63 (3.31)	ATAD6454	32.40 (3.01)	ATAD7040	28.05 (2.61)
ATAD5424	11.69 (1.09)	ATAD5874	39.15 (3.64)	ATAD6458	34.38 (3.19)	ATAD7044	30.26 (2.81)
ATAD5428	13.34 (1.24)	ATAD5880	42.66 (3.96)	ATAD6460	36.36 (3.38)	ATAD7048	32.46 (3.02)
ATAD5430	14.98 (1.39)	ATAD6010	6.49 (0.60)	ATAD6464	38.34 (3.56)	ATAD7050	34.66 (3.22)
ATAD5434	16.63 (1.54)	ATAD6020	12.09 (1.12)	ATAD6468	40.32 (3.75)	ATAD7054	36.86 (3.42)
ATAD5438	18.28 (1.70)	ATAD6024	13.96 (1.30)	ATAD6474	44.28 (4.11)		
ATAD5440	19.92 (1.85)	ATAD6028	15.83 (1.47)	ATAD6480	48.24 (4.48)		

• Dimensions in parentheses are in square meters.

continued on next page

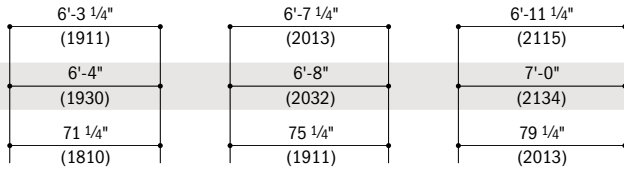

Custom-size windows are available in 1/8" (3) increments.

Contact your Andersen supplier for more information.

Direct-set arch (ATAD) window sizes shown.

Use window dimensions and minimum rough opening formula shown for sash-set arch (ATA) window sizes. For sash-set unobstructed glass dimensions, see pages 94-97. All sizes shown, along with custom sizes, are available with PG upgrade.

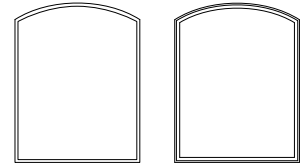

Direct-Set Arch

Sash-Set Arch

Grille patterns shown on page 105.

Details shown on page 111.

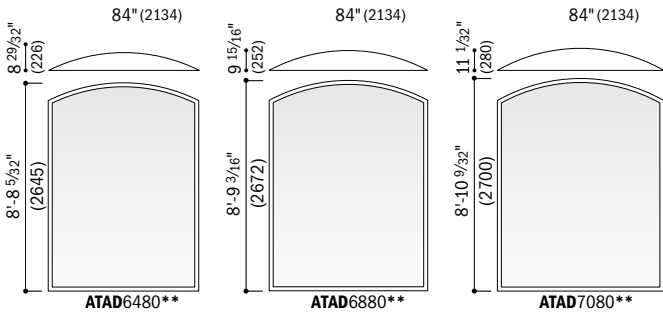

- * "Window Dimension" always refers to outside frame-to-frame dimension.
 - ** "Minimum Rough Opening" dimensions may need to be increased to allow for use of building wraps, flashing, sill panning, brackets, fasteners or other items. See pages 226-227 for more details.
 - * Dimensions in parentheses are in millimeters.
 - ** Tempered glass required. Some visual distortion may occur.
- continued on next page*

Direct-Set Arch Window Area Specifications *(continued)*

Window Number	Glass Area Sq. Ft./ (m ²)
ATAD7058	39.06 (3.63)
ATAD7060	41.26 (3.83)
ATAD7064	43.46 (4.04)
ATAD7068	45.67 (4.24)
ATAD7074	50.07 (4.65)
ATAD7080	54.47 (5.06)
ATAD7410	8.42 (0.78)
ATAD7420	15.36 (1.43)
ATAD7424	17.67 (1.64)
ATAD7428	19.98 (1.86)
ATAD7430	22.30 (2.07)
ATAD7434	24.61 (2.29)
ATAD7438	26.92 (2.50)
ATAD7440	29.23 (2.72)
ATAD7444	31.55 (2.93)
ATAD7448	33.86 (3.15)
ATAD7450	36.17 (3.36)
ATAD7454	38.48 (3.58)
ATAD7458	40.80 (3.76)
ATAD7460	43.11 (4.00)
ATAD71110	9.99 (0.93)
ATAD71120	17.52 (1.63)
ATAD71124	20.04 (1.86)
ATAD71128	22.55 (2.09)
ATAD71130	25.06 (2.33)
ATAD8010	10.18 (0.95)
ATAD8020	17.78 (1.65)
ATAD8024	20.32 (1.89)
ATAD8028	22.85 (2.12)
ATAD8030	25.39 (2.36)
ATAD8034	27.92 (2.59)
ATAD8038	30.46 (2.83)

Window Number	Glass Area Sq. Ft./ (m ²)
ATAD8040	32.99 (3.06)
ATAD8044	35.53 (3.30)
ATAD8048	38.06 (3.54)
ATAD8050	40.60 (3.77)
ATAD8054	43.13 (4.01)
ATAD8058	45.66 (4.24)
ATAD8060	48.20 (4.48)
ATAD8810	10.58 (0.98)
ATAD8820	18.85 (1.75)
ATAD8824	21.60 (2.01)
ATAD8828	24.36 (2.26)
ATAD8830	27.12 (2.52)
ATAD8834	29.87 (2.78)
ATAD8838	32.63 (3.03)
ATAD8840	35.39 (3.29)
ATAD8844	38.15 (3.54)
ATAD8848	40.90 (3.80)
ATAD8850	43.66 (4.06)
ATAD8854	46.42 (4.31)
ATAD8858	49.17 (4.57)
ATAD8860	51.93 (4.82)
ATAD81110	11.30 (1.05)
ATAD81120	19.83 (1.84)
ATAD81124	22.68 (2.11)
ATAD81128	25.52 (2.37)
ATAD81130	28.37 (2.64)
ATAD9410	12.46 (1.16)
ATAD9420	21.39 (1.99)
ATAD9424	24.37 (2.26)
ATAD9428	27.35 (2.54)
ATAD9430	30.33 (2.82)
ATAD9434	33.31 (3.09)

Window Number	Glass Area Sq. Ft./ (m ²)
ATAD9438	36.29 (3.37)
ATAD9440	39.27 (3.65)
ATAD9444	42.25 (3.92)
ATAD9448	45.23 (4.20)
ATAD9450	48.21 (4.48)
ATAD9454	51.18 (4.76)
ATAD9458	54.16 (5.03)
ATAD10010	14.60 (1.36)
ATAD10020	24.20 (2.25)
ATAD10024	27.40 (2.55)
ATAD10028	30.60 (2.84)
ATAD10030	33.80 (3.14)
ATAD10034	37.01 (3.44)
ATAD10038	40.21 (3.74)
ATAD10040	43.41 (4.03)
ATAD10044	46.61 (4.33)
ATAD10048	49.81 (4.63)
ATAD10050	53.01 (4.92)
ATAD10054	56.21 (5.22)
ATAD10058	59.42 (5.52)
ATAD10810	15.88 (1.47)
ATAD10820	26.15 (2.43)
ATAD10824	29.57 (2.75)
ATAD10828	32.99 (3.07)
ATAD10830	36.42 (3.38)
ATAD10834	39.84 (3.70)
ATAD10838	43.26 (4.02)
ATAD10840	46.69 (4.34)
ATAD10844	50.11 (4.66)
ATAD10848	53.54 (4.97)
ATAD10850	56.96 (5.29)
ATAD10854	60.38 (5.61)

Window Number	Glass Area Sq. Ft./ (m ²)
ATAD10858	63.81 (5.93)
ATAD11410	17.21 (1.60)
ATAD11420	28.15 (2.62)
ATAD11424	31.80 (2.95)
ATAD11428	35.44 (3.29)
ATAD11430	39.09 (3.63)
ATAD11434	42.74 (3.97)
ATAD11438	46.38 (4.31)
ATAD11440	50.03 (4.65)
ATAD11444	53.67 (4.99)
ATAD11448	57.32 (5.32)
ATAD11450	60.96 (5.66)
ATAD11454	64.61 (6.00)
ATAD12010	19.74 (1.83)
ATAD12020	31.34 (2.91)
ATAD12024	35.21 (3.27)
ATAD12028	39.08 (3.63)
ATAD12030	42.95 (3.99)
ATAD12034	46.82 (4.35)
ATAD12038	50.68 (4.71)
ATAD12040	54.55 (5.07)
ATAD12044	58.42 (5.43)
ATAD12048	62.29 (5.79)
ATAD12050	66.16 (6.15)
ATAD12054	70.02 (6.51)

* Dimensions in parentheses are in square meters.

SPECIALTY WINDOWS

Table of Direct-Set Arch Window Sizes (continued)

Scale $\frac{1}{8}$ " (3) = 1'-0" (305) – 1:96

Notes on the next page also apply to this page.

Window Dimension	8'-7 $\frac{1}{4}$ " (2623)	8'-10 $\frac{7}{16}$ " (2704)	9'-3 $\frac{1}{4}$ " (2826)	9'-11 $\frac{1}{4}$ " (3029)
Minimum Rough Opening	8'-8" (2642)	8'-11" (2718)	9'-4" (2845)	10'-0" (3048)
Unobstructed Glass	99 $\frac{1}{4}$ " (2521)	102 $\frac{7}{16}$ " (2602)	107 $\frac{1}{4}$ " (2724)	115 $\frac{1}{4}$ " (2927)

Window height shown in table	CUSTOM SIZES AVAILABLE			
	Radius	Chord Height	Shoulder Height	Unobstructed Glass = window height - 4" (102)
120" (3048)	120" (3048)	120" (3048)	120" (3048)	120" (3048)
11 $\frac{1}{4}$ " (286)	11 $\frac{1}{4}$ " (286)	11 $\frac{1}{4}$ " (286)	11 $\frac{1}{4}$ " (286)	11 $\frac{1}{4}$ " (286)
11'-10 $\frac{15}{16}$ " (3582)	11'-10 $\frac{15}{16}$ " (3582)	11'-10 $\frac{15}{16}$ " (3582)	11'-10 $\frac{15}{16}$ " (3582)	11'-10 $\frac{15}{16}$ " (3582)
23 $\frac{1}{4}$ " (591)	23 $\frac{1}{4}$ " (591)	23 $\frac{1}{4}$ " (591)	23 $\frac{1}{4}$ " (591)	23 $\frac{1}{4}$ " (591)
2'-11 $\frac{11}{16}$ " (602)	2'-11 $\frac{11}{16}$ " (602)	2'-11 $\frac{11}{16}$ " (602)	2'-11 $\frac{11}{16}$ " (602)	2'-11 $\frac{11}{16}$ " (602)
27 $\frac{1}{4}$ " (692)	27 $\frac{1}{4}$ " (692)	27 $\frac{1}{4}$ " (692)	27 $\frac{1}{4}$ " (692)	27 $\frac{1}{4}$ " (692)
3'-2 $\frac{15}{16}$ " (989)	3'-2 $\frac{15}{16}$ " (989)	3'-2 $\frac{15}{16}$ " (989)	3'-2 $\frac{15}{16}$ " (989)	3'-2 $\frac{15}{16}$ " (989)
31 $\frac{1}{4}$ " (794)	31 $\frac{1}{4}$ " (794)	31 $\frac{1}{4}$ " (794)	31 $\frac{1}{4}$ " (794)	31 $\frac{1}{4}$ " (794)
3'-6 $\frac{15}{16}$ " (1090)	3'-6 $\frac{15}{16}$ " (1090)	3'-6 $\frac{15}{16}$ " (1090)	3'-6 $\frac{15}{16}$ " (1090)	3'-6 $\frac{15}{16}$ " (1090)
35 $\frac{1}{4}$ " (895)	35 $\frac{1}{4}$ " (895)	35 $\frac{1}{4}$ " (895)	35 $\frac{1}{4}$ " (895)	35 $\frac{1}{4}$ " (895)
3'-10 $\frac{15}{16}$ " (1192)	3'-10 $\frac{15}{16}$ " (1192)	3'-10 $\frac{15}{16}$ " (1192)	3'-10 $\frac{15}{16}$ " (1192)	3'-10 $\frac{15}{16}$ " (1192)
39 $\frac{1}{4}$ " (997)	39 $\frac{1}{4}$ " (997)	39 $\frac{1}{4}$ " (997)	39 $\frac{1}{4}$ " (997)	39 $\frac{1}{4}$ " (997)
4'-2 $\frac{15}{16}$ " (1293)	4'-2 $\frac{15}{16}$ " (1293)	4'-2 $\frac{15}{16}$ " (1293)	4'-2 $\frac{15}{16}$ " (1293)	4'-2 $\frac{15}{16}$ " (1293)
43 $\frac{1}{4}$ " (1099)	43 $\frac{1}{4}$ " (1099)	43 $\frac{1}{4}$ " (1099)	43 $\frac{1}{4}$ " (1099)	43 $\frac{1}{4}$ " (1099)
4'-6 $\frac{15}{16}$ " (1395)	4'-6 $\frac{15}{16}$ " (1395)	4'-6 $\frac{15}{16}$ " (1395)	4'-6 $\frac{15}{16}$ " (1395)	4'-6 $\frac{15}{16}$ " (1395)
47 $\frac{1}{4}$ " (1200)	47 $\frac{1}{4}$ " (1200)	47 $\frac{1}{4}$ " (1200)	47 $\frac{1}{4}$ " (1200)	47 $\frac{1}{4}$ " (1200)
4'-10 $\frac{15}{16}$ " (1497)	4'-10 $\frac{15}{16}$ " (1497)	4'-10 $\frac{15}{16}$ " (1497)	4'-10 $\frac{15}{16}$ " (1497)	4'-10 $\frac{15}{16}$ " (1497)
51 $\frac{1}{4}$ " (1302)	51 $\frac{1}{4}$ " (1302)	51 $\frac{1}{4}$ " (1302)	51 $\frac{1}{4}$ " (1302)	51 $\frac{1}{4}$ " (1302)
5'-2 $\frac{15}{16}$ " (1598)	5'-2 $\frac{15}{16}$ " (1598)	5'-2 $\frac{15}{16}$ " (1598)	5'-2 $\frac{15}{16}$ " (1598)	5'-2 $\frac{15}{16}$ " (1598)
55 $\frac{1}{4}$ " (1403)	55 $\frac{1}{4}$ " (1403)	55 $\frac{1}{4}$ " (1403)	55 $\frac{1}{4}$ " (1403)	55 $\frac{1}{4}$ " (1403)
5'-6 $\frac{15}{16}$ " (1700)	5'-6 $\frac{15}{16}$ " (1700)	5'-6 $\frac{15}{16}$ " (1700)	5'-6 $\frac{15}{16}$ " (1700)	5'-6 $\frac{15}{16}$ " (1700)

*"Window Dimension" always refers to outside frame-to-frame dimension.
 **"Minimum Rough Opening" dimensions may need to be increased to allow for use of building wraps, flashing, sill panning, brackets, fasteners or other items. See pages 226-227 for more details.
 *Dimensions in parentheses are in millimeters.
 **Tempered glass required. Some visual distortion may occur.

10'-6 1/8" (3203)	11'-3 1/4" (3435)	11'-11 1/4" (3639)
10'-8" (3251)	11'-4" (3454)	12'-0" (3658)
123 1/4" (3131)	131 1/4" (3334)	139 1/4" (3537)



132" (3353) 2'-3 19/32" (701) 16 11/32" (415)	144" (3658) 2'-4 1/8" (714) 16 7/8" (428)	144" (3658) 2'-6 5/16" (770) 19 1/16" (485)
ATAD10810	ATAD11410	ATAD12010
3'-3 19/32" (1006)	3'-4 1/8" (1019)	3'-6 5/16" (1075)
ATAD10820**	ATAD11420**	ATAD12020**
3'-7 19/32" (1107)	3'-8 1/8" (1121)	3'-10 5/16" (1177)
ATAD10824**	ATAD11424**	ATAD12024**
3'-11 19/32" (1209)	4'-0 1/8" (1222)	4'-2 5/16" (1278)
ATAD10828**	ATAD11428**	ATAD12028**
4'-3 19/32" (1311)	4'-4 1/8" (1324)	4'-6 5/16" (1380)
ATAD10830**	ATAD11430**	ATAD12030**
4'-7 19/32" (1412)	4'-8 1/8" (1425)	4'-10 5/16" (1481)
ATAD10834**	ATAD11434**	ATAD12034**
4'-11 19/32" (1514)	5'-0 1/8" (1527)	5'-2 5/16" (1583)
ATAD10838**	ATAD11438**	ATAD12038**
5'-3 19/32" (1615)	5'-4 1/8" (1629)	5'-6 5/16" (1685)
ATAD10840**	ATAD11440**	ATAD12040**
5'-7 19/32" (1717)	5'-8 1/8" (1730)	5'-10 5/16" (1786)
ATAD10844**	ATAD11444**	ATAD12044**
5'-11 19/32" (1819)	6'-0 1/8" (1832)	6'-2 5/16" (1888)
ATAD10848**	ATAD11448**	ATAD12048**

Custom-size windows are available in 1/8" (3) increments. Contact your Andersen supplier for more information.

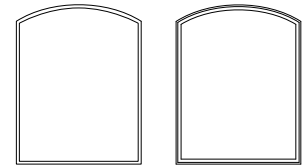

Direct-Set Arch Sash-Set Arch

Direct-set arch (ATAD) window sizes shown.

Use window dimensions and minimum rough opening formula shown for sash-set arch (ATA) window sizes. For sash-set unobstructed glass dimensions, see pages 94-97.

All sizes shown, along with custom sizes, are available with PG upgrade.

Grille patterns shown on page 105.

Details shown on page 111.

continued on next page

- "Window Dimension" always refers to outside frame-to-frame dimension.
- **Minimum Rough Opening** dimensions may need to be increased to allow for use of building wraps, flashing, sill panning, brackets, fasteners or other items. See pages 226-227 for more details.
- Dimensions in parentheses are in millimeters.
- **Tempered glass required. Some visual distortion may occur.

SPECIALTY WINDOWS

Table of Direct-Set Arch Window Sizes (continued)

Scale 1/8" (3) = 1'-0" (305) – 1:96

Notes on the next page also apply to this page.

Window Dimension	8'-7 1/4" (2623)	8'-10 7/16" (2704)	9'-3 1/4" (2826)	9'-11 1/4" (3029)
Minimum Rough Opening	8'-8" (2642)	8'-11" (2718)	9'-4" (2845)	10'-0" (3048)
Unobstructed Glass	99 1/4" (2521)	102 7/16" (2602)	107 1/4" (2724)	115 1/4" (2927)

CUSTOM SIZES AVAILABLE

Window height shown in table

Radius

Chord Height

Shoulder Height

Unobstructed Glass = window height - 4" (102)

Minimum Rough Opening = window height + 3/4" (19)

CUSTOM SIZES AVAILABLE

120" (3048) 120" (3048) 120" (3048) 120" (3048)

11 11/16" (296) 12 7/16" (316) 13 21/32" (347) 15 7/8" (403)

59 1/4" (1505) 5'-10 15/16" (1801) 6'-0 29/32" (1852) 6'-3 1/8" (1908)

ATAD8850** **ATAD9450**** **ATAD10050****

63 1/4" (1607) 6'-2 15/16" (1903) 6'-4 29/32" (1954) 6'-7 1/8" (2009)

ATAD8854** **ATAD9454**** **ATAD10054****

67 1/4" (1708) 6'-6 15/16" (2005) 6'-8 29/32" (2055) 6'-11 1/8" (2111)

ATAD8858** **ATAD9458**** **ATAD10058****

71 1/4" (1810) 6'-10 15/16" (2106) **ATAD8860****

- *"Window Dimension" always refers to outside frame-to-frame dimension.
- **"Minimum Rough Opening" dimensions may need to be increased to allow for use of building wraps, flashing, sill panning, brackets, fasteners or other items. See pages 226-227 for more details.
- *Dimensions in parentheses are in millimeters.
- **Tempered glass required. Some visual distortion may occur.

Sash-Set Arch Window Unobstructed Glass Dimensions and Area Specifications

Window Number	Unobstructed Glass Width Inches/(mm)	Unobstructed Glass Height Inches/(mm)	Glass Area Sq. Ft./ (m ²)
ATA2010	16 5/8" (421)	7 5/8" (193)	0.81 (0.08)
ATA2020	16 5/8" (421)	19 1/8" (498)	2.19 (0.20)
ATA2024	16 5/8" (421)	23 3/8" (599)	2.65 (0.25)
ATA2028	16 5/8" (421)	27 5/8" (701)	3.11 (0.29)
ATA2030	16 5/8" (421)	31 5/8" (803)	3.58 (0.33)
ATA2034	16 5/8" (421)	35 5/8" (904)	4.04 (0.37)
ATA2038	16 5/8" (421)	39 5/8" (1006)	4.50 (0.42)
ATA2040	16 5/8" (421)	43 5/8" (1107)	4.96 (0.46)
ATA2044	16 5/8" (421)	47 5/8" (1209)	5.42 (0.50)
ATA2048	16 5/8" (421)	51 5/8" (1311)	5.88 (0.55)
ATA2050	16 5/8" (421)	55 5/8" (1412)	6.34 (0.59)
ATA2054	16 5/8" (421)	59 5/8" (1514)	6.80 (0.63)
ATA2058	16 5/8" (421)	63 5/8" (1615)	7.26 (0.67)
ATA2060	16 5/8" (421)	67 5/8" (1717)	7.72 (0.72)
ATA2064	16 5/8" (421)	71 5/8" (1819)	8.18 (0.76)
ATA2068	16 5/8" (421)	75 5/8" (1920)	8.65 (0.80)
ATA2074	16 5/8" (421)	83 5/8" (2123)	9.57 (0.89)
ATA2080	16 5/8" (421)	91 5/8" (2327)	10.49 (0.97)
ATA2110	17 1/2" (444)	7 1/8" (181)	0.81 (0.07)
ATA2120	17 1/2" (444)	19 1/8" (486)	2.26 (0.21)

Window Number	Unobstructed Glass Width Inches/(mm)	Unobstructed Glass Height Inches/(mm)	Glass Area Sq. Ft./ (m ²)
ATA2124	17 1/2" (444)	23 1/8" (587)	2.75 (0.26)
ATA2128	17 1/2" (444)	27 1/8" (689)	3.23 (0.30)
ATA2130	17 1/2" (444)	31 1/8" (791)	3.72 (0.35)
ATA2410	20 5/8" (523)	7 7/8" (200)	1.03 (0.10)
ATA2420	20 5/8" (523)	19 7/8" (505)	2.74 (0.25)
ATA2424	20 5/8" (523)	23 7/8" (606)	3.32 (0.31)
ATA2428	20 5/8" (523)	27 7/8" (708)	3.89 (0.36)
ATA2430	20 5/8" (523)	31 7/8" (809)	4.46 (0.41)
ATA2434	20 5/8" (523)	35 7/8" (911)	5.03 (0.47)
ATA2438	20 5/8" (523)	39 7/8" (1013)	5.60 (0.52)
ATA2440	20 5/8" (523)	43 7/8" (1114)	6.18 (0.57)
ATA2444	20 5/8" (523)	47 7/8" (1216)	6.75 (0.63)
ATA2448	20 5/8" (523)	51 7/8" (1317)	7.32 (0.68)
ATA2450	20 5/8" (523)	55 7/8" (1419)	7.89 (0.73)
ATA2454	20 5/8" (523)	59 7/8" (1521)	8.46 (0.79)
ATA2458	20 5/8" (523)	63 7/8" (1622)	9.04 (0.84)
ATA2460	20 5/8" (523)	67 7/8" (1724)	9.61 (0.89)
ATA2464	20 5/8" (523)	71 7/8" (1825)	10.18 (0.95)
ATA2468	20 5/8" (523)	75 7/8" (1927)	10.75 (1.00)
ATA2474	20 5/8" (523)	83 7/8" (2130)	11.90 (1.11)

Window Number	Unobstructed Glass Width Inches/(mm)	Unobstructed Glass Height Inches/(mm)	Glass Area Sq. Ft./ (m ²)
ATA2480	20 5/8" (523)	91 1/8" (2333)	13.04 (1.21)
ATA2610	22 5/8" (574)	8 3/8" (213)	1.19 (0.11)
ATA2620	22 5/8" (574)	20 3/8" (518)	3.07 (0.29)
ATA2624	22 5/8" (574)	24 3/8" (620)	3.70 (0.34)
ATA2628	22 5/8" (574)	28 3/8" (721)	4.33 (0.40)
ATA2630	22 5/8" (574)	32 3/8" (823)	4.95 (0.46)
ATA2634	22 5/8" (574)	36 3/8" (925)	5.58 (0.52)
ATA2638	22 5/8" (574)	40 3/8" (1026)	6.21 (0.58)
ATA2640	22 5/8" (574)	44 3/8" (1128)	6.84 (0.64)
ATA2644	22 5/8" (574)	48 3/8" (1229)	7.47 (0.69)
ATA2648	22 5/8" (574)	52 3/8" (1331)	8.09 (0.75)
ATA2650	22 5/8" (574)	56 3/8" (1433)	8.72 (0.81)
ATA2654	22 5/8" (574)	60 3/8" (1534)	9.35 (0.87)
ATA2658	22 5/8" (574)	64 3/8" (1636)	9.98 (0.93)
ATA2660	22 5/8" (574)	68 3/8" (1737)	10.60 (0.99)
ATA2664	22 5/8" (574)	72 3/8" (1839)	11.23 (1.04)
ATA2668	22 5/8" (574)	76 3/8" (1941)	11.86 (1.10)
ATA2674	22 5/8" (574)	84 3/8" (2144)	13.11 (1.22)
ATA2680	22 5/8" (574)	92 3/8" (2347)	14.37 (1.33)

*Dimensions in parentheses are in millimeters or square meters.

continued on next page

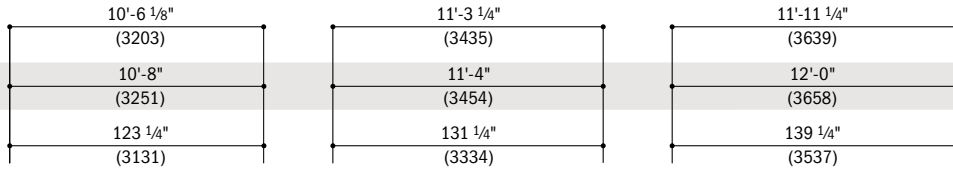

Custom-size windows are available in 1/8" (3) increments. Contact your Andersen supplier for more information.

Direct-set arch (ATAD) window sizes shown. Use window dimensions and minimum rough opening formula shown for sash-set arch (ATA) window sizes. For sash-set unobstructed glass dimensions, see pages 94-97.

All sizes shown, along with custom sizes, are available with PG upgrade.

Grille patterns shown on page 105. Details shown on page 111.

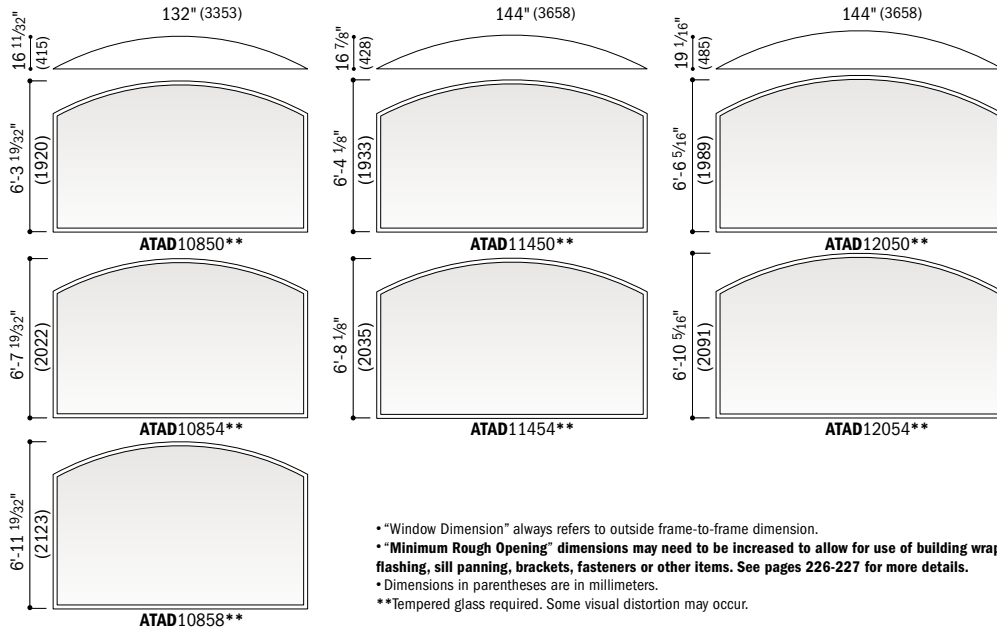

- "Window Dimension" always refers to outside frame-to-frame dimension.
- ****Minimum Rough Opening** dimensions may need to be increased to allow for use of building wraps, flashing, sill panning, brackets, fasteners or other items. See pages 226-227 for more details.**
- Dimensions in parentheses are in millimeters.
- **Tempered glass required. Some visual distortion may occur.

Sash-Set Arch Window Unobstructed Glass Dimensions and Area Specifications *(continued)*

Window Number	Unobstructed Glass Width Inches/(mm)	Unobstructed Glass Height Inches/(mm)	Glass Area Sq. Ft./ (m ²)
ATA2710	23 1/2" (596)	7 7/8" (201)	1.17 (0.11)
ATA2720	23 1/2" (596)	19 7/8" (505)	3.13 (0.29)
ATA2724	23 1/2" (596)	23 7/8" (607)	3.78 (0.35)
ATA2728	23 1/2" (596)	27 7/8" (709)	4.43 (0.41)
ATA2730	23 1/2" (596)	31 7/8" (810)	5.08 (0.47)
ATA2810	24 3/8" (625)	8 3/16" (207)	1.26 (0.12)
ATA2820	24 3/8" (625)	20 3/16" (512)	3.31 (0.31)
ATA2824	24 3/8" (625)	24 3/16" (614)	3.99 (0.37)
ATA2828	24 3/8" (625)	28 3/16" (715)	4.68 (0.43)
ATA2830	24 3/8" (625)	32 3/16" (817)	5.36 (0.50)
ATA2834	24 3/8" (625)	36 3/16" (919)	6.04 (0.56)
ATA2838	24 3/8" (625)	40 3/16" (1020)	6.72 (0.62)
ATA2840	24 3/8" (625)	44 3/16" (1122)	7.41 (0.69)
ATA2844	24 3/8" (625)	48 3/16" (1223)	8.09 (0.75)
ATA2848	24 3/8" (625)	52 3/16" (1325)	8.77 (0.82)
ATA2850	24 3/8" (625)	56 3/16" (1427)	9.46 (0.88)
ATA2854	24 3/8" (625)	60 3/16" (1528)	10.14 (0.94)
ATA2858	24 3/8" (625)	64 3/16" (1630)	10.82 (1.01)
ATA2860	24 3/8" (625)	68 3/16" (1731)	11.51 (1.07)
ATA2864	24 3/8" (625)	72 3/16" (1833)	12.19 (1.13)
ATA2868	24 3/8" (625)	76 3/16" (1935)	12.87 (1.20)
ATA2874	24 3/8" (625)	84 3/16" (2138)	14.24 (1.32)
ATA2880	24 3/8" (625)	92 3/16" (2341)	15.61 (1.45)
ATA2910	25 1/2" (647)	8 3/8" (213)	1.33 (0.12)
ATA2920	25 1/2" (647)	20 3/8" (518)	3.45 (0.32)
ATA2924	25 1/2" (647)	24 3/8" (619)	4.16 (0.39)
ATA2928	25 1/2" (647)	28 3/8" (721)	4.87 (0.45)

Window Number	Unobstructed Glass Width Inches/(mm)	Unobstructed Glass Height Inches/(mm)	Glass Area Sq. Ft./ (m ²)
ATA2930	25 1/2" (647)	32 3/8" (822)	5.58 (0.52)
ATA2910G	25 3/4" (653)	8 7/16" (214)	1.35 (0.13)
ATA2920G	25 3/4" (653)	20 7/16" (519)	3.50 (0.32)
ATA2924G	25 3/4" (653)	24 7/16" (621)	4.21 (0.39)
ATA2928G	25 3/4" (653)	28 7/16" (722)	4.92 (0.46)
ATA2930G	25 3/4" (653)	32 7/16" (824)	5.64 (0.52)
ATA21010	26 3/8" (675)	8 11/16" (220)	1.43 (0.13)
ATA21020	26 3/8" (675)	20 11/16" (525)	3.65 (0.34)
ATA21024	26 3/8" (675)	24 11/16" (626)	4.38 (0.41)
ATA21028	26 3/8" (675)	28 11/16" (728)	5.12 (0.48)
ATA21030	26 3/8" (675)	32 11/16" (830)	5.86 (0.54)
ATA21034	26 3/8" (675)	36 11/16" (931)	6.60 (0.61)
ATA21038	26 3/8" (675)	40 11/16" (1033)	7.34 (0.68)
ATA21040	26 3/8" (675)	44 11/16" (1134)	8.08 (0.75)
ATA21044	26 3/8" (675)	48 11/16" (1236)	8.82 (0.82)
ATA21048	26 3/8" (675)	52 11/16" (1338)	9.55 (0.89)
ATA21050	26 3/8" (675)	56 11/16" (1439)	10.29 (0.96)
ATA21054	26 3/8" (675)	60 11/16" (1541)	11.03 (1.02)
ATA21058	26 3/8" (675)	64 11/16" (1642)	11.77 (1.09)
ATA21060	26 3/8" (675)	68 11/16" (1744)	12.51 (1.16)
ATA21064	26 3/8" (675)	72 11/16" (1846)	13.25 (1.23)
ATA21068	26 3/8" (675)	76 11/16" (1947)	13.99 (1.30)
ATA21074	26 3/8" (675)	84 11/16" (2150)	15.46 (1.44)
ATA21080	26 3/8" (675)	92 11/16" (2354)	16.94 (1.57)
ATA3010	28 3/8" (726)	9 3/16" (234)	1.61 (0.15)
ATA3020	28 3/8" (726)	21 3/16" (539)	4.00 (0.37)
ATA3024	28 3/8" (726)	25 3/16" (640)	4.79 (0.45)

Window Number	Unobstructed Glass Width Inches/(mm)	Unobstructed Glass Height Inches/(mm)	Glass Area Sq. Ft./ (m ²)
ATA3028	28 3/8" (726)	29 3/16" (742)	5.59 (0.52)
ATA3030	28 3/8" (726)	33 3/16" (843)	6.38 (0.59)
ATA3034	28 3/8" (726)	37 3/16" (945)	7.17 (0.67)
ATA3038	28 3/8" (726)	41 3/16" (1047)	7.97 (0.74)
ATA3040	28 3/8" (726)	45 3/16" (1148)	8.76 (0.81)
ATA3044	28 3/8" (726)	49 3/16" (1250)	9.56 (0.89)
ATA3048	28 3/8" (726)	53 3/16" (1351)	10.35 (0.96)
ATA3050	28 3/8" (726)	57 3/16" (1453)	11.15 (1.04)
ATA3054	28 3/8" (726)	61 3/16" (1555)	11.94 (1.11)
ATA3058	28 3/8" (726)	65 3/16" (1656)	12.73 (1.18)
ATA3060	28 3/8" (726)	69 3/16" (1758)	13.53 (1.26)
ATA3064	28 3/8" (726)	73 3/16" (1859)	14.32 (1.33)
ATA3068	28 3/8" (726)	77 3/16" (1961)	15.12 (1.40)
ATA3074	28 3/8" (726)	85 3/16" (2164)	16.71 (1.55)
ATA3080	28 3/8" (726)	93 3/16" (2367)	18.29 (1.70)
ATA3110	29 1/2" (749)	9 7/16" (240)	1.70 (0.16)
ATA3120	29 1/2" (749)	21 7/16" (545)	4.16 (0.39)
ATA3124	29 1/2" (749)	25 7/16" (647)	4.97 (0.46)
ATA3128	29 1/2" (749)	29 7/16" (748)	5.79 (0.54)
ATA3130	29 1/2" (749)	33 7/16" (850)	6.61 (0.61)
ATA3210	30 5/8" (777)	8 15/16" (227)	1.68 (0.16)
ATA3220	30 5/8" (777)	20 15/16" (532)	4.23 (0.39)
ATA3224	30 5/8" (777)	24 15/16" (634)	5.08 (0.47)
ATA3228	30 5/8" (777)	28 15/16" (735)	5.93 (0.55)
ATA3230	30 5/8" (777)	32 15/16" (837)	6.78 (0.63)

• Dimensions in parentheses are in millimeters or square meters.

continued on next page

SPECIALTY WINDOWS

Sash-Set Arch Window Unobstructed Glass Dimensions and Area Specifications *(continued)*

Window Number	Unobstructed Glass Width Inches/(mm)	Unobstructed Glass Height Inches/(mm)	Glass Area Sq. Ft./ (m ²)
ATA3234	30 5/8" (777)	36 15/16" (939)	7.63 (0.71)
ATA3238	30 5/8" (777)	40 15/16" (1040)	8.48 (0.79)
ATA3240	30 5/8" (777)	44 15/16" (1142)	9.33 (0.87)
ATA3244	30 5/8" (777)	48 15/16" (1243)	10.18 (0.95)
ATA3248	30 5/8" (777)	52 15/16" (1345)	11.03 (1.02)
ATA3250	30 5/8" (777)	56 15/16" (1447)	11.88 (1.10)
ATA3254	30 5/8" (777)	60 15/16" (1548)	12.73 (1.18)
ATA3258	30 5/8" (777)	64 15/16" (1650)	13.58 (1.26)
ATA3260	30 5/8" (777)	68 15/16" (1751)	14.43 (1.34)
ATA3264	30 5/8" (777)	72 15/16" (1853)	15.28 (1.42)
ATA3268	30 5/8" (777)	76 15/16" (1955)	16.13 (1.50)
ATA3274	30 5/8" (777)	84 15/16" (2158)	17.83 (1.66)
ATA3280	30 5/8" (777)	92 15/16" (2361)	19.53 (1.81)
ATA3310	31 1/2" (799)	9 3/16" (233)	1.76 (0.16)
ATA3320	31 1/2" (799)	21 3/16" (538)	4.39 (0.41)
ATA3324	31 1/2" (799)	25 3/16" (639)	5.26 (0.49)
ATA3328	31 1/2" (799)	29 3/16" (741)	6.14 (0.57)
ATA3330	31 1/2" (799)	33 3/16" (842)	7.01 (0.65)
ATA3310G	31 3/4" (806)	9 1/4" (235)	1.79 (0.17)
ATA3320G	31 3/4" (806)	21 1/4" (539)	4.43 (0.41)
ATA3324G	31 3/4" (806)	25 1/4" (641)	5.31 (0.49)
ATA3328G	31 3/4" (806)	29 1/4" (743)	6.19 (0.58)
ATA3330G	31 3/4" (806)	33 1/4" (844)	7.08 (0.66)
ATA3410	32 5/8" (828)	9 7/16" (240)	1.88 (0.17)
ATA3420	32 5/8" (828)	21 7/16" (545)	4.59 (0.43)
ATA3424	32 5/8" (828)	25 7/16" (647)	5.50 (0.51)
ATA3428	32 5/8" (828)	29 7/16" (748)	6.40 (0.59)
ATA3430	32 5/8" (828)	33 7/16" (850)	7.31 (0.68)
ATA3434	32 5/8" (828)	37 7/16" (952)	8.21 (0.76)
ATA3438	32 5/8" (828)	41 7/16" (1053)	9.12 (0.85)
ATA3440	32 5/8" (828)	45 7/16" (1155)	10.02 (0.93)
ATA3444	32 5/8" (828)	49 7/16" (1256)	10.93 (1.02)
ATA3448	32 5/8" (828)	53 7/16" (1358)	11.83 (1.10)
ATA3450	32 5/8" (828)	57 7/16" (1460)	12.74 (1.18)
ATA3454	32 5/8" (828)	61 7/16" (1561)	13.65 (1.27)
ATA3458	32 5/8" (828)	65 7/16" (1663)	14.55 (1.35)
ATA3460	32 5/8" (828)	69 7/16" (1764)	15.46 (1.44)
ATA3464	32 5/8" (828)	73 7/16" (1866)	16.36 (1.52)
ATA3468	32 5/8" (828)	77 7/16" (1968)	17.27 (1.60)
ATA3474	32 5/8" (828)	85 7/16" (2131)	19.08 (1.77)
ATA3480	32 5/8" (828)	93 7/16" (2374)	20.89 (1.94)
ATA3810	36 5/8" (929)	9 3/4" (247)	2.15 (0.20)
ATA3820	36 5/8" (929)	21 3/4" (552)	5.20 (0.48)
ATA3824	36 5/8" (929)	25 3/4" (654)	6.22 (0.58)
ATA3828	36 5/8" (929)	29 3/4" (755)	7.23 (0.67)
ATA3830	36 5/8" (929)	33 3/4" (857)	8.25 (0.77)
ATA3834	36 5/8" (929)	37 3/4" (959)	9.27 (0.86)
ATA3838	36 5/8" (929)	41 3/4" (1060)	10.28 (0.96)
ATA3840	36 5/8" (929)	45 3/4" (1162)	11.30 (1.05)
ATA3844	36 5/8" (929)	49 3/4" (1263)	12.31 (1.14)
ATA3848	36 5/8" (929)	53 3/4" (1365)	13.33 (1.24)
ATA3850	36 5/8" (929)	57 3/4" (1467)	14.35 (1.33)
ATA3854	36 5/8" (929)	61 3/4" (1568)	15.36 (1.43)
ATA3858	36 5/8" (929)	65 3/4" (1670)	16.38 (1.52)
ATA3860	36 5/8" (929)	69 3/4" (1771)	17.40 (1.62)
ATA3864	36 5/8" (929)	73 3/4" (1873)	18.41 (1.71)
ATA3868	36 5/8" (929)	77 3/4" (1975)	19.43 (1.81)
ATA3874	36 5/8" (929)	85 3/4" (2138)	21.46 (1.99)
ATA3880	36 5/8" (929)	93 3/4" (2381)	23.50 (2.18)
ATA3910	37 3/4" (958)	10" (255)	2.27 (0.21)
ATA3920	37 3/4" (958)	22" (560)	5.41 (0.50)

Window Number	Unobstructed Glass Width Inches/(mm)	Unobstructed Glass Height Inches/(mm)	Glass Area Sq. Ft./ (m ²)
ATA3924	37 3/4" (958)	26" (661)	6.46 (0.60)
ATA3928	37 3/4" (958)	30" (763)	7.51 (0.70)
ATA3930	37 3/4" (958)	34" (864)	8.56 (0.79)
ATA4010	40 5/8" (1031)	10 13/16" (275)	2.60 (0.24)
ATA4020	40 5/8" (1031)	22 13/16" (579)	5.98 (0.56)
ATA4024	40 5/8" (1031)	26 13/16" (681)	7.11 (0.66)
ATA4028	40 5/8" (1031)	30 13/16" (783)	8.24 (0.77)
ATA4030	40 5/8" (1031)	34 13/16" (884)	9.37 (0.87)
ATA4034	40 5/8" (1031)	38 13/16" (986)	10.49 (0.97)
ATA4038	40 5/8" (1031)	42 13/16" (1087)	11.62 (1.08)
ATA4040	40 5/8" (1031)	46 13/16" (1189)	12.75 (1.18)
ATA4044	40 5/8" (1031)	50 13/16" (1291)	13.88 (1.29)
ATA4048	40 5/8" (1031)	54 13/16" (1392)	15.00 (1.39)
ATA4050	40 5/8" (1031)	58 13/16" (1494)	16.13 (1.50)
ATA4054	40 5/8" (1031)	62 13/16" (1595)	17.26 (1.60)
ATA4058	40 5/8" (1031)	66 13/16" (1697)	18.39 (1.71)
ATA4060	40 5/8" (1031)	70 13/16" (1799)	19.51 (1.81)
ATA4064	40 5/8" (1031)	74 13/16" (2000)	20.64 (1.92)
ATA4068	40 5/8" (1031)	78 13/16" (2002)	21.77 (2.02)
ATA4074	40 5/8" (1031)	86 13/16" (2205)	24.02 (2.23)
ATA4080	40 5/8" (1031)	94 13/16" (2408)	26.28 (2.44)
ATA4310	43 3/4" (1110)	10 1/8" (257)	2.64 (0.25)
ATA4320	43 3/4" (1110)	22 1/8" (562)	6.28 (0.58)
ATA4324	43 3/4" (1110)	26 1/8" (664)	7.50 (0.70)
ATA4328	43 3/4" (1110)	30 1/8" (765)	8.71 (0.81)
ATA4330	43 3/4" (1110)	34 1/8" (867)	9.93 (0.92)
ATA4410	44 5/8" (1133)	10 5/16" (263)	2.74 (0.25)
ATA4420	44 5/8" (1133)	22 5/16" (567)	6.45 (0.60)
ATA4424	44 5/8" (1133)	26 5/16" (669)	7.69 (0.71)
ATA4428	44 5/8" (1133)	30 5/16" (771)	8.93 (0.83)
ATA4430	44 5/8" (1133)	34 5/16" (872)	10.17 (0.94)
ATA4434	44 5/8" (1133)	38 5/16" (974)	11.41 (1.06)
ATA4438	44 5/8" (1133)	42 5/16" (1075)	12.65 (1.18)
ATA4440	44 5/8" (1133)	46 5/16" (1177)	13.89 (1.29)
ATA4444	44 5/8" (1133)	50 5/16" (1279)	15.13 (1.41)
ATA4448	44 5/8" (1133)	54 5/16" (1380)	16.36 (1.52)
ATA4450	44 5/8" (1133)	58 5/16" (1482)	17.60 (1.64)
ATA4454	44 5/8" (1133)	62 5/16" (1583)	18.84 (1.75)
ATA4458	44 5/8" (1133)	66 5/16" (1685)	20.08 (1.87)
ATA4460	44 5/8" (1133)	70 5/16" (1787)	21.32 (1.98)
ATA4464	44 5/8" (1133)	74 5/16" (1888)	22.56 (2.10)
ATA4468	44 5/8" (1133)	78 5/16" (1990)	23.80 (2.21)
ATA4474	44 5/8" (1133)	86 5/16" (2193)	26.27 (2.44)
ATA4480	44 5/8" (1133)	94 5/16" (2396)	28.75 (2.67)
ATA4810	48 5/8" (1234)	11 1/16" (288)	3.22 (0.30)
ATA4820	48 5/8" (1234)	23 5/16" (593)	7.27 (0.68)
ATA4824	48 5/8" (1234)	27 5/16" (694)	8.62 (0.80)
ATA4828	48 5/8" (1234)	31 5/16" (796)	9.97 (0.93)
ATA4830	48 5/8" (1234)	35 5/16" (897)	11.32 (1.05)
ATA4834	48 5/8" (1234)	39 5/16" (999)	12.67 (1.18)
ATA4838	48 5/8" (1234)	43 5/16" (1101)	14.02 (1.30)
ATA4840	48 5/8" (1234)	47 5/16" (1202)	15.37 (1.43)
ATA4844	48 5/8" (1234)	51 5/16" (1304)	16.72 (1.55)
ATA4848	48 5/8" (1234)	55 5/16" (1405)	18.07 (1.68)
ATA4850	48 5/8" (1234)	59 5/16" (1507)	19.42 (1.80)
ATA4854	48 5/8" (1234)	63 5/16" (1609)	20.77 (1.93)
ATA4858	48 5/8" (1234)	67 5/16" (1710)	22.12 (2.05)
ATA4860	48 5/8" (1234)	71 5/16" (1812)	23.47 (2.18)
ATA4864	48 5/8" (1234)	75 5/16" (1913)	24.82 (2.31)
ATA4868	48 5/8" (1234)	79 5/16" (2015)	26.17 (2.43)
ATA4874	48 5/8" (1234)	87 5/16" (2218)	28.87 (2.68)

Window Number	Unobstructed Glass Width Inches/(mm)	Unobstructed Glass Height Inches/(mm)	Glass Area Sq. Ft./ (m ²)
ATA4880	48 5/8" (1234)	95 5/16" (2421)	31.57 (2.93)
ATA5010	52 5/8" (1336)	12 7/16" (315)	3.77 (0.35)
ATA5020	52 5/8" (1336)	24 7/16" (620)	8.15 (0.76)
ATA5024	52 5/8" (1336)	28 7/16" (722)	9.61 (0.89)
ATA5028	52 5/8" (1336)	32 7/16" (823)	11.07 (1.03)
ATA5030	52 5/8" (1336)	36 7/16" (925)	12.53 (1.16)
ATA5034	52 5/8" (1336)	40 7/16" (1027)	13.99 (1.30)
ATA5038	52 5/8" (1336)	44 7/16" (1128)	15.45 (1.44)
ATA5040	52 5/8" (1336)	48 7/16" (1230)	16.92 (1.57)
ATA5044	52 5/8" (1336)	52 7/16" (1331)	18.38 (1.71)
ATA5048	52 5/8" (1336)	56 7/16" (1433)	19.84 (1.84)
ATA5050	52 5/8" (1336)	60 7/16" (1535)	21.30 (1.98)
ATA5054	52 5/8" (1336)	64 7/16" (1636)	22.76 (2.11)
ATA5058	52 5/8" (1336)	68 7/16" (1738)	24.22 (2.25)
ATA5060	52 5/8" (1336)	72 7/16" (1839)	25.68 (2.39)
ATA5064	52 5/8" (1336)	76 7/16" (1941)	27.14 (2.52)
ATA5068	52 5/8" (1336)	80 7/16" (2043)	28.60 (2.66)
ATA5074	52 5/8" (1336)	88 7/16" (2246)	31.52 (2.93)
ATA5080	52 5/8" (1336)	96 7/16" (2449)	34.45 (3.20)
ATA5410	56 5/8" (1437)	11 15/16" (303)	3.90 (0.36)
ATA5420	56 5/8" (1437)	23 15/16" (607)	8.61 (0.80)
ATA5424	56 5/8" (1437)	27 15/16" (709)	10.18 (0.95)
ATA5428	56 5/8" (1437)	31 15/16" (811)	11.76 (1.09)
ATA5430	56 5/8" (1437)	35 15/16" (912)	13.33 (1.24)
ATA5434	56 5/8" (1437)	39 15/16" (1014)	14.90 (1.38)
ATA5438	56 5/8" (1437)	43 15/16" (1115)	16.47 (1.53)
ATA5440	56 5/8" (1437)	47 15/16" (1213)	18.05 (1.68)
ATA5444	56 5/8" (1437)	51 15/16" (1319)	19.62 (1.82)
ATA5448	56 5/8" (1437)	55 15/16" (1420)	21.19 (1.97)
ATA5450	56 5/8" (1437)	59 15/16" (1522)	22.76 (2.11)
ATA5454	56 5/8" (1437)	63 15/16" (1623)	24.33 (2.26)
ATA5458	56 5/8" (1437)	67 15/16" (1725)	25.91 (2.41)
ATA5460	56 5/8" (1437)	71 15/16" (1827)	27.48 (2.55)
ATA5464	56 5/8" (1437)	75 15/16" (1928)	29.05 (2.70)
ATA5468	56 5/8" (1437)	79 15/16" (2030)	30.62 (2.84)
ATA5474	56 5/8" (1437)	87 15/16" (2233)	33.77 (3.14)
ATA5480	56 5/8" (1437)	95 15/16" (2436)	36.91 (3.43)
ATA5810	60 5/8" (1539)	12 15/16" (328)	4.47 (0.42)
ATA5820	60 5/8" (1539)	24 15/16" (633)	9.52 (0.88)
ATA5824	60 5/8" (1539)	28 15/16" (735)	11.21 (1.04)
ATA5828	60 5/8" (1539)	32 15/16" (836)	12.89 (1.20)
ATA5830	60 5/8" (1539)	36 15/16" (938)	14.57 (1.35)
ATA5834	60 5/8" (1539)	40 15/16" (1040)	16.26 (1.51)
ATA5838	60 5/8" (1539)	44 15/16" (1141)	17.94 (1.67)
ATA5840	60 5/8" (1539)	48 15/16" (1243)	19.62 (1.82)
ATA5844	60 5/8" (1539)	52 15/16" (1344)	21.30 (1.98)
ATA5848	60 5/8" (1539)	56 15/16" (1446)	22.99 (2.14)
ATA5850	60 5/8" (1539)	60 15/16" (1548)	24.67 (2.29)
ATA5854	60 5/8" (1539)	64 15/16" (1649)	26.35 (2.45)
ATA5858	60 5/8" (1539)	68 15/16" (1751)	28.04 (2.60)
ATA5860	60 5/8" (1539)	72 15/16" (1852)	29.72 (2.76)
ATA5864	60 5/8" (1539)	76 15/16" (1954)	31.40 (2.92)
ATA5868	60 5/8" (1539)	80 15/16" (2056)	33.09 (3.07)
ATA5874	60 5/8" (1539)	88 15/16" (2259)	36.45 (3.39)
ATA5880	60 5/8" (1539)	96 15/16" (2462)	39.82 (3.70)
ATA6010	64 5/8" (1641)	14" (356)	5.11 (0.48)
ATA6020	64 5/8" (1641)	26" (661)	10.50 (0.98)
ATA6024	64 5/8" (1641)	30" (763)	12.29 (1.14)
ATA6028	64 5/8" (1641)	34" (864)	14.09 (1.31)
ATA6030	64 5/8" (1641)	38" (966)	15.88 (1.48)

* Dimensions in parentheses are in millimeters or square meters.

continued on next page

Sash-Set Arch Window Unobstructed Glass Dimensions and Area Specifications *(continued)*

Window Number	Unobstructed Glass Width Inches/(mm)	Unobstructed Glass Height Inches/(mm)	Glass Area Sq. Ft./ (m ²)
ATA6034	64 5/8" (1641)	42" (1067)	17.67 (1.64)
ATA6038	64 5/8" (1641)	46" (1169)	19.47 (1.81)
ATA6040	64 5/8" (1641)	50" (1271)	21.26 (1.98)
ATA6044	64 5/8" (1641)	54" (1372)	23.06 (2.14)
ATA6048	64 5/8" (1641)	58" (1474)	24.85 (2.31)
ATA6050	64 5/8" (1641)	62" (1575)	26.65 (2.48)
ATA6054	64 5/8" (1641)	66" (1677)	28.44 (2.64)
ATA6058	64 5/8" (1641)	70" (1779)	30.23 (2.81)
ATA6060	64 5/8" (1641)	74" (1880)	32.03 (2.98)
ATA6064	64 5/8" (1641)	78" (1982)	33.82 (3.14)
ATA6068	64 5/8" (1641)	82" (2083)	35.62 (3.31)
ATA6074	64 5/8" (1641)	90" (2287)	39.21 (3.64)
ATA6080	64 5/8" (1641)	98" (2490)	42.79 (3.98)
ATA6410	68 5/8" (1742)	13 1/2" (343)	5.24 (0.49)
ATA6420	68 5/8" (1742)	25 1/2" (647)	10.95 (1.02)
ATA6424	68 5/8" (1742)	29 1/2" (749)	12.86 (1.19)
ATA6428	68 5/8" (1742)	33 1/2" (851)	14.76 (1.37)
ATA6430	68 5/8" (1742)	37 1/2" (952)	16.67 (1.55)
ATA6434	68 5/8" (1742)	41 1/2" (1054)	18.57 (1.73)
ATA6438	68 5/8" (1742)	45 1/2" (1155)	20.48 (1.90)
ATA6440	68 5/8" (1742)	49 1/2" (1257)	22.38 (2.08)
ATA6444	68 5/8" (1742)	53 1/2" (1359)	24.29 (2.26)
ATA6448	68 5/8" (1742)	57 1/2" (1460)	26.19 (2.43)
ATA6450	68 5/8" (1742)	61 1/2" (1562)	28.10 (2.61)
ATA6454	68 5/8" (1742)	65 1/2" (1663)	30.01 (2.79)
ATA6458	68 5/8" (1742)	69 1/2" (1765)	31.91 (2.96)
ATA6460	68 5/8" (1742)	73 1/2" (1867)	33.82 (3.14)
ATA6464	68 5/8" (1742)	77 1/2" (1968)	35.72 (3.32)
ATA6468	68 5/8" (1742)	81 1/2" (2070)	37.63 (3.50)
ATA6474	68 5/8" (1742)	89 1/2" (2273)	41.44 (3.85)
ATA6480	68 5/8" (1742)	97 1/2" (2476)	45.25 (4.20)
ATA6810	72 5/8" (1844)	14 1/2" (369)	5.91 (0.55)
ATA6820	72 5/8" (1844)	26 1/2" (674)	11.96 (1.11)
ATA6824	72 5/8" (1844)	30 1/2" (775)	13.97 (1.30)
ATA6828	72 5/8" (1844)	34 1/2" (877)	15.99 (1.49)
ATA6830	72 5/8" (1844)	38 1/2" (979)	18.01 (1.67)
ATA6834	72 5/8" (1844)	42 1/2" (1080)	20.02 (1.86)
ATA6838	72 5/8" (1844)	46 1/2" (1182)	22.04 (2.05)
ATA6840	72 5/8" (1844)	50 1/2" (1283)	24.05 (2.23)
ATA6844	72 5/8" (1844)	54 1/2" (1385)	26.07 (2.42)
ATA6848	72 5/8" (1844)	58 1/2" (1487)	28.09 (2.61)
ATA6850	72 5/8" (1844)	62 1/2" (1588)	30.10 (2.80)
ATA6854	72 5/8" (1844)	66 1/2" (1690)	32.12 (2.98)
ATA6858	72 5/8" (1844)	70 1/2" (1791)	34.14 (3.17)
ATA6860	72 5/8" (1844)	74 1/2" (1893)	36.15 (3.36)
ATA6864	72 5/8" (1844)	78 1/2" (1995)	38.17 (3.55)
ATA6868	72 5/8" (1844)	82 1/2" (2096)	40.19 (3.73)
ATA6874	72 5/8" (1844)	90 1/2" (2299)	44.22 (4.11)
ATA6880	72 5/8" (1844)	98 1/2" (2503)	48.25 (4.48)
ATA7010	76 5/8" (1945)	15 5/8" (397)	6.64 (0.62)
ATA7020	76 5/8" (1945)	27 5/8" (702)	13.03 (1.21)
ATA7024	76 5/8" (1945)	31 5/8" (803)	15.15 (1.41)
ATA7028	76 5/8" (1945)	35 5/8" (905)	17.28 (1.61)
ATA7030	76 5/8" (1945)	39 5/8" (1007)	19.41 (1.80)
ATA7034	76 5/8" (1945)	43 5/8" (1108)	21.54 (2.00)
ATA7038	76 5/8" (1945)	47 5/8" (1210)	23.66 (2.20)
ATA7040	76 5/8" (1945)	51 5/8" (1311)	25.79 (2.40)
ATA7044	76 5/8" (1945)	55 5/8" (1413)	27.92 (2.59)
ATA7048	76 5/8" (1945)	59 5/8" (1515)	30.05 (2.79)
ATA7050	76 5/8" (1945)	63 5/8" (1616)	32.18 (2.99)
ATA7054	76 5/8" (1945)	67 5/8" (1718)	34.30 (3.19)

Window Number	Unobstructed Glass Width Inches/(mm)	Unobstructed Glass Height Inches/(mm)	Glass Area Sq. Ft./ (m ²)
ATA7058	76 5/8" (1945)	71 5/8" (1819)	36.43 (3.38)
ATA7060	76 5/8" (1945)	75 5/8" (1921)	38.56 (3.58)
ATA7064	76 5/8" (1945)	79 5/8" (2023)	40.69 (3.78)
ATA7068	76 5/8" (1945)	83 5/8" (2124)	42.81 (3.98)
ATA7074	76 5/8" (1945)	91 5/8" (2327)	47.07 (4.37)
ATA7080	76 5/8" (1945)	99 5/8" (2531)	51.32 (4.77)
ATA7410	80 5/8" (2047)	15 1/16" (383)	6.76 (0.63)
ATA7420	80 5/8" (2047)	27 1/16" (688)	13.47 (1.25)
ATA7424	80 5/8" (2047)	31 1/16" (789)	15.71 (1.46)
ATA7428	80 5/8" (2047)	35 1/16" (891)	17.95 (1.67)
ATA7430	80 5/8" (2047)	39 1/16" (993)	20.19 (1.88)
ATA7434	80 5/8" (2047)	43 1/16" (1094)	22.43 (2.08)
ATA7438	80 5/8" (2047)	47 1/16" (1196)	24.66 (2.29)
ATA7440	80 5/8" (2047)	51 1/16" (1297)	26.90 (2.50)
ATA7444	80 5/8" (2047)	55 1/16" (1399)	29.14 (2.71)
ATA7448	80 5/8" (2047)	59 1/16" (1501)	31.38 (2.92)
ATA7450	80 5/8" (2047)	63 1/16" (1602)	33.62 (3.12)
ATA7454	80 5/8" (2047)	67 1/16" (1704)	35.86 (3.33)
ATA7458	80 5/8" (2047)	71 1/16" (1805)	38.10 (3.54)
ATA7460	80 5/8" (2047)	75 1/16" (1907)	40.34 (3.75)
ATA71110	87 13/16" (2230)	17" (432)	8.18 (0.76)
ATA71120	87 13/16" (2230)	29" (737)	15.49 (1.44)
ATA71124	87 13/16" (2230)	33" (838)	17.93 (1.67)
ATA71128	87 13/16" (2230)	37" (940)	20.37 (1.89)
ATA71130	87 13/16" (2230)	41" (1042)	22.81 (2.12)
ATA8010	88 5/8" (2250)	17 1/4" (438)	8.35 (0.78)
ATA8020	88 5/8" (2250)	29 1/4" (743)	15.74 (1.46)
ATA8024	88 5/8" (2250)	33 1/4" (844)	18.20 (1.69)
ATA8028	88 5/8" (2250)	37 1/4" (946)	20.66 (1.92)
ATA8030	88 5/8" (2250)	41 1/4" (1047)	23.12 (2.15)
ATA8034	88 5/8" (2250)	45 1/4" (1149)	25.58 (2.38)
ATA8038	88 5/8" (2250)	49 1/4" (1251)	28.04 (2.61)
ATA8040	88 5/8" (2250)	53 1/4" (1352)	30.50 (2.83)
ATA8044	88 5/8" (2250)	57 1/4" (1454)	32.96 (3.06)
ATA8048	88 5/8" (2250)	61 1/4" (1555)	35.42 (3.29)
ATA8050	88 5/8" (2250)	65 1/4" (1657)	37.89 (3.52)
ATA8054	88 5/8" (2250)	69 1/4" (1759)	40.35 (3.75)
ATA8058	88 5/8" (2250)	73 1/4" (1860)	42.81 (3.98)
ATA8060	88 5/8" (2250)	77 1/4" (1962)	45.27 (4.21)
ATA8810	96 5/8" (2453)	16 1/4" (413)	8.61 (0.80)
ATA8820	96 5/8" (2453)	28 1/4" (718)	16.66 (1.55)
ATA8824	96 5/8" (2453)	32 1/4" (820)	19.35 (1.80)
ATA8828	96 5/8" (2453)	36 1/4" (921)	22.03 (2.05)
ATA8830	96 5/8" (2453)	40 1/4" (1023)	24.71 (2.30)
ATA8834	96 5/8" (2453)	44 1/4" (1124)	27.40 (2.55)
ATA8838	96 5/8" (2453)	48 1/4" (1226)	30.08 (2.79)
ATA8840	96 5/8" (2453)	52 1/4" (1328)	32.76 (3.04)
ATA8844	96 5/8" (2453)	56 1/4" (1429)	35.45 (3.29)
ATA8848	96 5/8" (2453)	60 1/4" (1531)	38.13 (3.54)
ATA8850	96 5/8" (2453)	64 1/4" (1632)	40.81 (3.79)
ATA8854	96 5/8" (2453)	68 1/4" (1734)	43.50 (4.04)
ATA8858	96 5/8" (2453)	72 1/4" (1836)	46.18 (4.29)
ATA8860	96 5/8" (2453)	76 1/4" (1937)	48.86 (4.54)
ATA81110	99 13/16" (2534)	17 1/16" (433)	9.27 (0.86)
ATA81120	99 13/16" (2534)	29 1/16" (738)	17.59 (1.63)
ATA81124	99 13/16" (2534)	33 1/16" (839)	20.36 (1.89)
ATA81128	99 13/16" (2534)	37 1/16" (941)	23.13 (2.15)
ATA81130	99 13/16" (2534)	41 1/16" (1042)	25.90 (2.41)
ATA9410	104 5/8" (2657)	18 1/4" (464)	10.34 (0.96)
ATA9420	104 5/8" (2657)	30 1/4" (769)	19.05 (1.77)
ATA9424	104 5/8" (2657)	34 1/4" (870)	21.96 (2.04)

Window Number	Unobstructed Glass Width Inches/(mm)	Unobstructed Glass Height Inches/(mm)	Glass Area Sq. Ft./ (m ²)
ATA9428	104 5/8" (2657)	38 1/4" (972)	24.86 (2.31)
ATA9430	104 5/8" (2657)	42 1/4" (1074)	27.77 (2.58)
ATA9434	104 5/8" (2657)	46 1/4" (1175)	30.67 (2.85)
ATA9438	104 5/8" (2657)	50 1/4" (1277)	33.58 (3.12)
ATA9440	104 5/8" (2657)	54 1/4" (1378)	36.49 (3.39)
ATA9444	104 5/8" (2657)	58 1/4" (1480)	39.39 (3.66)
ATA9448	104 5/8" (2657)	62 1/4" (1582)	42.30 (3.93)
ATA9450	104 5/8" (2657)	66 1/4" (1683)	45.20 (4.20)
ATA9454	104 5/8" (2657)	70 1/4" (1785)	48.11 (4.47)
ATA9458	104 5/8" (2657)	74 1/4" (1886)	51.01 (4.74)
ATA10010	112 5/8" (2860)	20 7/16" (520)	12.32 (1.14)
ATA10020	112 5/8" (2860)	32 7/16" (824)	21.70 (2.02)
ATA10024	112 5/8" (2860)	36 7/16" (926)	24.83 (2.31)
ATA10028	112 5/8" (2860)	40 7/16" (1028)	27.96 (2.60)
ATA10030	112 5/8" (2860)	44 7/16" (1129)	31.08 (2.89)
ATA10034	112 5/8" (2860)	48 7/16" (1231)	34.21 (3.18)
ATA10038	112 5/8" (2860)	52 7/16" (1332)	37.34 (3.47)
ATA10040	112 5/8" (2860)	56 7/16" (1434)	40.47 (3.76)
ATA10044	112 5/8" (2860)	60 7/16" (1536)	43.59 (4.05)
ATA10048	112 5/8" (2860)	64 7/16" (1637)	46.72 (4.34)
ATA10050	112 5/8" (2860)	68 7/16" (1739)	49.85 (4.63)
ATA10054	112 5/8" (2860)	72 7/16" (1840)	52.98 (4.92)
ATA10058	112 5/8" (2860)	76 7/16" (1942)	56.11 (5.21)
ATA10810	120 5/8" (3063)	20 7/16" (532)	13.45 (1.25)
ATA10820	120 5/8" (3063)	32 7/16" (837)	23.50 (2.18)
ATA10824	120 5/8" (3063)	36 7/16" (938)	26.85 (2.49)
ATA10828	120 5/8" (3063)	40 7/16" (1040)	30.20 (2.81)
ATA10830	120 5/8" (3063)	44 7/16" (1141)	33.55 (3.12)
ATA10834	120 5/8" (3063)	48 7/16" (1243)	36.90 (3.43)
ATA10838	120 5/8" (3063)	52 7/16" (1345)	40.25 (3.74)
ATA10840	120 5/8" (3063)	56 7/16" (1446)	43.60 (4.05)
ATA10844	120 5/8" (3063)	60 7/16" (1548)	46.95 (4.36)
ATA10848	120 5/8" (3063)	64 7/16" (1649)	50.30 (4.67)
ATA10850	120 5/8" (3063)	68 7/16" (1751)	53.65 (4.98)
ATA10854	120 5/8" (3063)	72 7/16" (1853)	57.00 (5.30)
ATA10858	120 5/8" (3063)	76 7/16" (1954)	60.35 (5.61)
ATA11410	128 5/8" (3266)	20 7/16" (545)	14.64 (1.36)
ATA11420	128 5/8" (3266)	32 7/16" (850)	25.36 (2.36)
ATA11424	128 5/8" (3266)	36 7/16" (952)	28.93 (2.69)
ATA11428	128 5/8" (3266)	40 7/16" (1053)	32.50 (3.02)
ATA11430	128 5/8" (3266)	44 7/16" (1155)	36.07 (3.35)
ATA11434	128 5/8" (3266)	48 7/16" (1256)	39.65 (3.68)
ATA11438	128 5/8" (3266)	52 7/16" (1358)	43.22 (4.02)
ATA11440	128 5/8" (3266)	56 7/16" (1460)	46.79 (4.35)
ATA11444	128 5/8" (3266)	60 7/16" (1561)	50.36 (4.68)
ATA11448	128 5/8" (3266)	64 7/16" (1663)	53.94 (5.01)
ATA11450	128 5/8" (3266)	68 7/16" (1764)	57.51 (5.34)
ATA11454	128 5/8" (3266)	72 7/16" (1866)	61.08 (5.67)
ATA12010	136 5/8" (3469)	20 7/16" (601)	17.01 (1.58)
ATA12020	136 5/8" (3469)	32 7/16" (906)	28.39 (2.64)
ATA12024	136 5/8" (3469)	36 7/16" (1008)	32.19 (2.99)
ATA12028	136 5/8" (3469)	40 7/16" (1109)	35.98 (3.34)
ATA12030	136 5/8" (3469)	44 7/16" (1211)	39.77 (3.70)
ATA12034	136 5/8" (3469)	48 7/16" (1312)	43.57 (4.05)
ATA12038	136 5/8" (3469)	52 7/16" (1414)	47.36 (4.40)
ATA12040	136 5/8" (3469)	56 7/16" (1516)	51.16 (4.75)
ATA12044	136 5/8" (3469)	60 7/16" (1617)	54.95 (5.10)
ATA12048	136 5/8" (3469)	64 7/16" (1719)	58.75 (5.46)
ATA12050	136 5/8" (3469)	68 7/16" (1820)	62.54 (5.81)
ATA12054	136 5/8" (3469)	72 7/16" (1922)	66.33 (6.16)

*Dimensions in parentheses are in millimeters or square meters.

SPECIALTY WINDOWS

Table of Direct-Set Springline™ Window Sizes

Scale 1/8" (3) = 1'-0" (305) – 1:96

Notes on page 106 also apply to this page.

Window Width Dimension	1'-7 1/4" (489)	1'-11 1/4" (591)	2'-3 1/4" (692)	2'-5 1/4" (743)	2'-7 1/4" (794)	2'-9 1/4" (845)	2'-11 1/4" (895)	3'-1 1/4" (946)	3'-3 1/4" (997)
Minimum Rough Opening	1'-8" (508)	2'-0" (610)	2'-4" (711)	2'-6" (762)	2'-8" (813)	2'-10" (864)	3'-0" (914)	3'-2" (965)	3'-4" (1016)
Unobstructed Glass	15 1/4" (387)	19 1/4" (489)	23 1/4" (591)	25 1/4" (641)	27 1/4" (692)	29 1/4" (743)	31 1/4" (794)	33 1/4" (845)	35 1/4" (895)

CUSTOM SIZES AVAILABLE

Window height shown in table

Radius	9 5/8" (244)	11 5/8" (295)	13 5/8" (346)	14 5/8" (371)	15 5/8" (397)	16 5/8" (422)	17 5/8" (448)	18 5/8" (473)	19 5/8" (498)
--------	--------------	---------------	---------------	---------------	---------------	---------------	---------------	---------------	---------------

Chord Height	9 5/8" (244)	11 5/8" (295)	13 5/8" (346)	14 5/8" (371)	15 5/8" (397)	16 5/8" (422)	17 5/8" (448)	18 5/8" (473)	19 5/8" (498)
--------------	--------------	---------------	---------------	---------------	---------------	---------------	---------------	---------------	---------------

Shoulder Height	6 1/4" (159)	1'-3 7/8" (403)	1'-5 7/8" (454)	1'-7 7/8" (505)	1'-8 7/8" (530)	1'-9 7/8" (556)	1'-10 7/8" (581)	1'-11 7/8" (606)	2'-0 7/8" (632)	2'-1 7/8" (657)
	ATSD1807	ATSD2007	ATSD2407	ATSD2607	ATSD2807	ATSD21007	ATSD3007	ATSD3207	ATSD3407	

Shoulder Height	11 1/4" (286)	1'-8 7/8" (530)	1'-10 7/8" (581)	2'-0 7/8" (632)	2'-1 7/8" (657)	2'-2 7/8" (683)	2'-3 7/8" (708)	2'-4 7/8" (733)	2'-5 7/8" (759)	2'-6 7/8" (784)
	ATSD1810	ATSD2010	ATSD2410	ATSD2610	ATSD2810	ATSD21010	ATSD3010	ATSD3210	ATSD3410	

Shoulder Height	23 1/4" (591)	2'-8 7/8" (635)	2'-10 7/8" (686)	3'-0 7/8" (937)	3'-1 7/8" (962)	3'-2 7/8" (987)	3'-3 7/8" (1013)	3'-4 7/8" (1038)	3'-5 7/8" (1064)	3'-6 7/8" (1089)
	ATSD1820	ATSD2020	ATSD2420	ATSD2620	ATSD2820	ATSD21020	ATSD3020	ATSD3220	ATSD3420	

Shoulder Height	27 1/4" (692)	3'-0 7/8" (937)	3'-2 7/8" (987)	3'-4 7/8" (1038)	3'-5 7/8" (1064)	3'-6 7/8" (1089)	3'-7 7/8" (1114)	3'-8 7/8" (1140)	3'-9 7/8" (1166)	3'-10 7/8" (1191)
	ATSD1824	ATSD2024	ATSD2424	ATSD2624	ATSD2824	ATSD21024	ATSD3024	ATSD3224	ATSD3424	

Shoulder Height	31 1/4" (794)	3'-4 7/8" (1038)	3'-6 7/8" (1089)	3'-8 7/8" (1140)	3'-9 7/8" (1165)	3'-10 7/8" (1191)	3'-11 7/8" (1216)	4'-0 7/8" (1241)	4'-1 7/8" (1267)	4'-2 7/8" (1292)
	ATSD1828	ATSD2028	ATSD2428	ATSD2628	ATSD2828	ATSD21028	ATSD3028	ATSD3228	ATSD3428	

Shoulder Height	35 1/4" (895)	3'-8 7/8" (1140)	3'-10 7/8" (1191)	4'-0 7/8" (1241)	4'-1 7/8" (1267)	4'-2 7/8" (1292)	4'-3 7/8" (1318)	4'-4 7/8" (1343)	4'-5 7/8" (1368)	4'-6 7/8" (1394)
	ATSD1830	ATSD2030	ATSD2430	ATSD2630	ATSD2830	ATSD21030	ATSD3030	ATSD3230	ATSD3430	

Shoulder Height	39 1/4" (997)	4'-0 7/8" (1241)	4'-2 7/8" (1292)	4'-4 7/8" (1343)	4'-5 7/8" (1368)	4'-6 7/8" (1394)	4'-7 7/8" (1419)	4'-8 7/8" (1445)	4'-9 7/8" (1470)	4'-10 7/8" (1495)
	ATSD1834	ATSD2034	ATSD2434	ATSD2634	ATSD2834	ATSD21034	ATSD3034	ATSD3234	ATSD3434	

Shoulder Height	43 1/4" (1099)	4'-4 7/8" (1343)	4'-6 7/8" (1394)	4'-8 7/8" (1445)	4'-9 7/8" (1470)	4'-10 7/8" (1495)	4'-11 7/8" (1521)	5'-0 7/8" (1546)	5'-1 7/8" (1572)	5'-2 7/8" (1597)
	ATSD1838	ATSD2038	ATSD2438	ATSD2638	ATSD2838	ATSD21038	ATSD3038	ATSD3238	ATSD3438	

Minimum Rough Opening = window height + 3/4" (19)
 Unobstructed Glass = window height - 4" (102)

CUSTOM SIZES AVAILABLE

• "Window Dimension" always refers to outside frame-to-frame dimension.
 • "Minimum Rough Opening" dimensions may need to be increased to allow for use of building wraps, flashing, sill panning, brackets, fasteners or other items. See pages 226-227 for more details.
 • Dimensions in parentheses are in millimeters.

Notes on page 106 also apply to this page.

3'-7 1/4" (1099)	3'-11 1/4" (1200)	4'-3 1/4" (1302)	4'-7 1/4" (1403)	4'-11 1/4" (1505)	5'-3 1/4" (1607)	5'-7 1/4" (1708)	5'-11 1/4" (1810)
3'-8" (1118)	4'-0" (1219)	4'-4" (1321)	4'-8" (1422)	5'-0" (1524)	5'-4" (1626)	5'-8" (1727)	6'-0" (1829)
39 1/4" (997)	43 1/4" (1099)	47 1/4" (1200)	51 1/4" (1302)	55 1/4" (1403)	59 1/4" (1505)	63 1/4" (1607)	67 1/4" (1708)
21 5/8" (549)	23 5/8" (600)	25 5/8" (651)	27 5/8" (702)	29 5/8" (752)	31 5/8" (803)	33 5/8" (854)	35 5/8" (905)
21 5/8" (549)	23 5/8" (600)	25 5/8" (651)	27 5/8" (702)	29 5/8" (752)	31 5/8" (803)	33 5/8" (854)	35 5/8" (905)
2'-3 7/8" (708)	2'-5 7/8" (759)	2'-7 7/8" (810)	2'-9 7/8" (860)	2'-11 7/8" (911)	3'-1 7/8" (962)	3'-3 7/8" (1013)	3'-5 7/8" (1064)
ATSD3807	ATSD4007	ATSD4407	ATSD4807	ATSD5007	ATSD5407	ATSD5807	ATSD6007
2'-8 7/8" (835)	2'-10 7/8" (886)	3'-0 7/8" (937)	3'-2 7/8" (987)	3'-4 7/8" (1038)	3'-6 7/8" (1089)	3'-8 7/8" (1140)	3'-10 7/8" (1191)
ATSD3810	ATSD4010	ATSD4410	ATSD4810	ATSD5010	ATSD5410	ATSD5810	ATSD6010
3'-8 7/8" (1140)	3'-10 7/8" (1191)	4'-0 7/8" (1241)	4'-2 7/8" (1292)	4'-4 7/8" (1343)	4'-6 7/8" (1394)	4'-8 7/8" (1445)	4'-10 7/8" (1495)
ATSD3820	ATSD4020	ATSD4420	ATSD4820	ATSD5020	ATSD5420	ATSD5820	ATSD6020
4'-0 7/8" (1241)	4'-2 7/8" (1292)	4'-4 7/8" (1343)	4'-6 7/8" (1394)	4'-8 7/8" (1445)	4'-10 7/8" (1495)	5'-0 7/8" (1546)	5'-2 7/8" (1597)
ATSD3824	ATSD4024	ATSD4424	ATSD4824	ATSD5024	ATSD5424	ATSD5824	ATSD6024
4'-4 7/8" (1343)	4'-6 7/8" (1394)	4'-8 7/8" (1445)	4'-10 7/8" (1495)	5'-0 7/8" (1546)	5'-2 7/8" (1597)	5'-4 7/8" (1648)	5'-6 7/8" (1699)
ATSD3828	ATSD4028*	ATSD4428*	ATSD4828*	ATSD5028	ATSD5428	ATSD5828	ATSD6028
4'-8 7/8" (1445)	4'-10 7/8" (1495)	5'-0 7/8" (1546)	5'-2 7/8" (1597)	5'-4 7/8" (1648)	5'-6 7/8" (1699)	5'-8 7/8" (1749)	5'-10 7/8" (1800)
ATSD3830	ATSD4030	ATSD4430	ATSD4830	ATSD5030	ATSD5430	ATSD5830	ATSD6030
5'-0 7/8" (1546)	5'-2 7/8" (1597)	5'-4 7/8" (1648)	5'-6 7/8" (1699)	5'-8 7/8" (1749)	5'-10 7/8" (1800)	6'-0 7/8" (1851)	6'-2 7/8" (1902)
ATSD3834	ATSD4034	ATSD4434	ATSD4834	ATSD5034	ATSD5434	ATSD5834	ATSD6034
5'-4 7/8" (1648)	5'-6 7/8" (1699)	5'-8 7/8" (1749)	5'-10 7/8" (1800)	6'-0 7/8" (1851)	6'-2 7/8" (1902)	6'-4 7/8" (1953)	6'-6 7/8" (2003)
ATSD3838	ATSD4038	ATSD4438	ATSD4838	ATSD5038	ATSD5438	ATSD5838	ATSD6038

continued on next page

- "Window Dimension" always refers to outside frame-to-frame dimension.
- "Minimum Rough Opening" dimensions may need to be increased to allow for use of building wraps, flashing, sill panning, brackets, fasteners or other items. See pages 226-227 for more details.
- Dimensions in parentheses are in millimeters.

SPECIALTY WINDOWS

Table of Direct-Set Springline™ Window Sizes (continued)

Scale 1/8" (3) = 1'-0" (305) – 1:96

Notes on page 106 also apply to this page.

Window Width Dimension	1'-7 1/4" (489)	1'-11 1/4" (591)	2'-3 1/4" (692)	2'-5 1/4" (743)	2'-7 1/4" (794)	2'-9 1/4" (845)	2'-11 1/4" (895)	3'-1 1/4" (946)	3'-3 1/4" (997)
Minimum Rough Opening	1'-8" (508)	2'-0" (610)	2'-4" (711)	2'-6" (762)	2'-8" (813)	2'-10" (864)	3'-0" (914)	3'-2" (965)	3'-4" (1016)
Unobstructed Glass	15 1/4" (387)	19 1/4" (489)	23 1/4" (591)	25 1/4" (641)	27 1/4" (692)	29 1/4" (743)	31 1/4" (794)	33 1/4" (845)	35 1/4" (895)

CUSTOM SIZES AVAILABLE

Window height shown in table	Radius	9 5/8" (244)	11 5/8" (295)	13 5/8" (346)	14 5/8" (371)	15 5/8" (397)	16 5/8" (422)	17 5/8" (448)	18 5/8" (473)	19 5/8" (498)
Chord Height		9 5/8" (244)	11 5/8" (295)	13 5/8" (346)	14 5/8" (371)	15 5/8" (397)	16 5/8" (422)	17 5/8" (448)	18 5/8" (473)	19 5/8" (498)
Shoulder Height	47 1/4" (1200)	ATSD1840	ATSD2040	ATSD2440	ATSD2640	ATSD2840	ATSD21040	ATSD3040	ATSD3240	ATSD3440
	4'-8 7/8" (1445)	ATSD1840	ATSD2040	ATSD2440	ATSD2640	ATSD2840	ATSD21040	ATSD3040	ATSD3240	ATSD3440
	5'-1 7/8" (1517)	ATSD1840	ATSD2040	ATSD2440	ATSD2640	ATSD2840	ATSD21040	ATSD3040	ATSD3240	ATSD3440
	5'-2 7/8" (1597)	ATSD1844	ATSD2044	ATSD2444	ATSD2644	ATSD2844	ATSD21044	ATSD3044	ATSD3244	ATSD3444
	5'-10 7/8" (1673)	ATSD1848	ATSD2048	ATSD2448	ATSD2648	ATSD2848	ATSD21048	ATSD3048	ATSD3248	ATSD3448
	5'-11 7/8" (1775)	ATSD1850	ATSD2050	ATSD2450	ATSD2650	ATSD2850	ATSD21050	ATSD3050	ATSD3250	ATSD3450
	6'-0 7/8" (1800)	ATSD1854	ATSD2054	ATSD2454	ATSD2654	ATSD2854	ATSD21054	ATSD3054	ATSD3254	ATSD3454
	6'-2 7/8" (1876)	ATSD1858	ATSD2058	ATSD2458	ATSD2658	ATSD2858	ATSD21058	ATSD3058	ATSD3258	ATSD3458
	6'-4 7/8" (1953)	ATSD1854	ATSD2054	ATSD2454	ATSD2654	ATSD2854	ATSD21054	ATSD3054	ATSD3254	ATSD3454
	6'-6 7/8" (1978)	ATSD1854	ATSD2054	ATSD2454	ATSD2654	ATSD2854	ATSD21054	ATSD3054	ATSD3254	ATSD3454
6'-8 7/8" (2054)	ATSD1854	ATSD2054	ATSD2454	ATSD2654	ATSD2854	ATSD21054	ATSD3054	ATSD3254	ATSD3454	
6'-10 7/8" (2105)	ATSD1854	ATSD2054	ATSD2454	ATSD2654	ATSD2854	ATSD21054	ATSD3054	ATSD3254	ATSD3454	
6'-11 7/8" (2130)	ATSD1858	ATSD2058	ATSD2458	ATSD2658	ATSD2858	ATSD21058	ATSD3058	ATSD3258	ATSD3458	
7'-0 7/8" (2156)	ATSD1858	ATSD2058	ATSD2458	ATSD2658	ATSD2858	ATSD21058	ATSD3058	ATSD3258	ATSD3458	
7'-1 7/8" (2181)	ATSD1858	ATSD2058	ATSD2458	ATSD2658	ATSD2858	ATSD21058	ATSD3058	ATSD3258	ATSD3458	
7'-2 7/8" (2207)	ATSD1858	ATSD2058	ATSD2458	ATSD2658	ATSD2858	ATSD21058	ATSD3058	ATSD3258	ATSD3458	

Minimum Rough Opening = window height + 3/4" (19)
 Unobstructed Glass = window height - 4" (102)

• "Window Dimension" always refers to outside frame-to-frame dimension.
 • "Minimum Rough Opening" dimensions may need to be increased to allow for use of building wraps, flashing, sill panning, brackets, fasteners or other items. See pages 226-227 for more details.
 • Dimensions in parentheses are in millimeters.

Notes on page 106 also apply to this page.

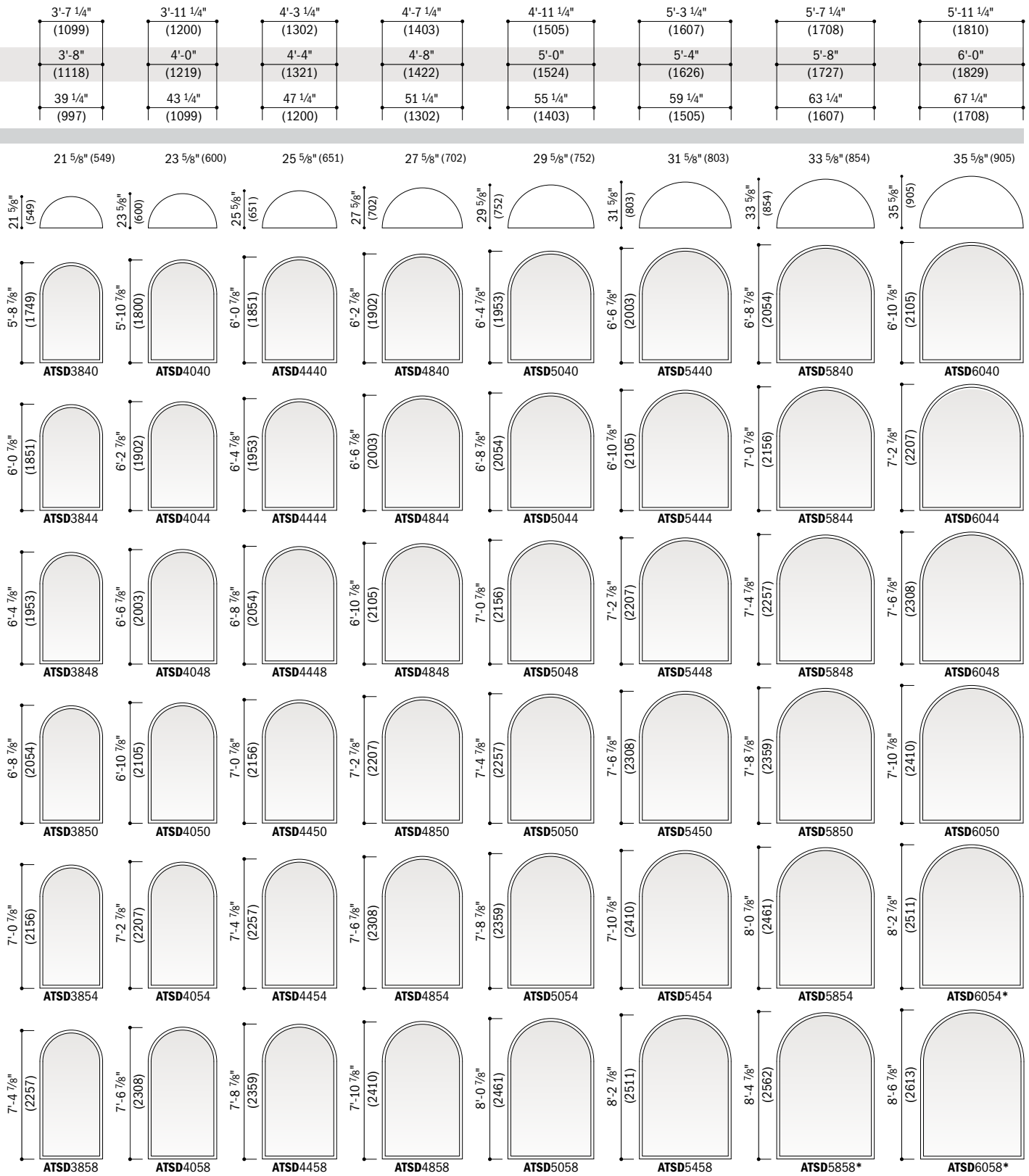

continued on next page

- *"Window Dimension" always refers to outside frame-to-frame dimension.
- **"Minimum Rough Opening" dimensions may need to be increased to allow for use of building wraps, flashing, sill panning, brackets, fasteners or other items. See pages 226-227 for more details.
- Dimensions in parentheses are in millimeters.
- *Tempered glass required. Some visual distortion may occur.

SPECIALTY WINDOWS

Table of Direct-Set Springline™ Window Sizes (continued)

Notes on page 106 also apply to this page.

Scale 1/8" (3) = 1'-0" (305) – 1:96

Window Width Dimension	1'-7 1/4" (489)	1'-11 1/4" (591)	2'-3 1/4" (692)	2'-5 1/4" (743)	2'-7 1/4" (794)	2'-9 1/4" (845)	2'-11 1/4" (895)	3'-1 1/4" (946)	3'-3 1/4" (997)
Minimum Rough Opening	1'-8" (508)	2'-0" (610)	2'-4" (711)	2'-6" (762)	2'-8" (813)	2'-10" (864)	3'-0" (914)	3'-2" (965)	3'-4" (1016)
Unobstructed Glass	15 1/4" (387)	19 1/4" (489)	23 1/4" (591)	25 1/4" (641)	27 1/4" (692)	29 1/4" (743)	31 1/4" (794)	33 1/4" (845)	35 1/4" (895)

CUSTOM SIZES AVAILABLE

Window height shown in table

Radius	9 5/8" (244)	11 5/8" (295)	13 5/8" (346)	14 5/8" (371)	15 5/8" (397)	16 5/8" (422)	17 5/8" (448)	18 5/8" (473)	19 5/8" (498)
--------	--------------	---------------	---------------	---------------	---------------	---------------	---------------	---------------	---------------

Chord Height	9 5/8" (244)	11 5/8" (295)	13 5/8" (346)	14 5/8" (371)	15 5/8" (397)	16 5/8" (422)	17 5/8" (448)	18 5/8" (473)	19 5/8" (498)
--------------	--------------	---------------	---------------	---------------	---------------	---------------	---------------	---------------	---------------

Minimum Rough Opening = window height + 3/4" (19)
 Unobstructed Glass = window height - 4" (102)

CUSTOM SIZES AVAILABLE

Shoulder Height	71 1/4" (1810)	6'-10 7/8" (2105)	7'-0 7/8" (2156)	7'-1 7/8" (2181)	7'-2 7/8" (2207)	7'-3 7/8" (2232)	7'-4 7/8" (2257)	7'-5 7/8" (2283)	7'-6 7/8" (2308)
ATSD1860	ATSD2060	ATSD2460	ATSD2660	ATSD2860	ATSD21060	ATSD3060	ATSD3260	ATSD3460	
75 1/4" (1911)	7'-0 7/8" (2156)	7'-2 7/8" (2207)	7'-4 7/8" (2257)	7'-5 7/8" (2283)	7'-6 7/8" (2308)	7'-7 7/8" (2334)	7'-8 7/8" (2359)	7'-9 7/8" (2384)	7'-10 7/8" (2410)
ATSD1864	ATSD2064	ATSD2464	ATSD2664	ATSD2864	ATSD21064	ATSD3064	ATSD3264	ATSD3464	
79 1/4" (2013)	7'-4 7/8" (2257)	7'-6 7/8" (2308)	7'-8 7/8" (2359)	7'-9 7/8" (2384)	7'-10 7/8" (2410)	7'-11 7/8" (2435)	8'-0 7/8" (2461)	8'-1 7/8" (2486)	8'-2 7/8" (2511)
ATSD1868	ATSD2068	ATSD2468	ATSD2668	ATSD2868	ATSD21068	ATSD3068	ATSD3268	ATSD3468	
87 1/4" (2216)	8'-0 7/8" (2461)	8'-2 7/8" (2511)	8'-4 7/8" (2562)	8'-5 7/8" (2588)	8'-6 7/8" (2613)	8'-7 7/8" (2638)	8'-8 7/8" (2664)	8'-9 7/8" (2689)	8'-10 7/8" (2715)
ATSD1874	ATSD2074	ATSD2474	ATSD2674	ATSD2874	ATSD21074	ATSD3074	ATSD3274	ATSD3474	
95 1/4" (2419)	8'-8 7/8" (2664)	8'-10 7/8" (2715)	9'-0 7/8" (2765)	9'-1 7/8" (2791)	9'-2 7/8" (2816)	9'-3 7/8" (2842)	9'-4 7/8" (2867)	9'-5 7/8" (2892)	9'-6 7/8" (2918)
ATSD1880	ATSD2080	ATSD2480	ATSD2680	ATSD2880	ATSD21080	ATSD3080	ATSD3280	ATSD3480	

• "Window Dimension" always refers to outside frame-to-frame dimension.
 • "Minimum Rough Opening" dimensions may need to be increased to allow for use of building wraps, flashing, sill panning, brackets, fasteners or other items. See pages 226-227 for more details.
 • Dimensions in parentheses are in millimeters.

Notes on page 106 also apply to this page.

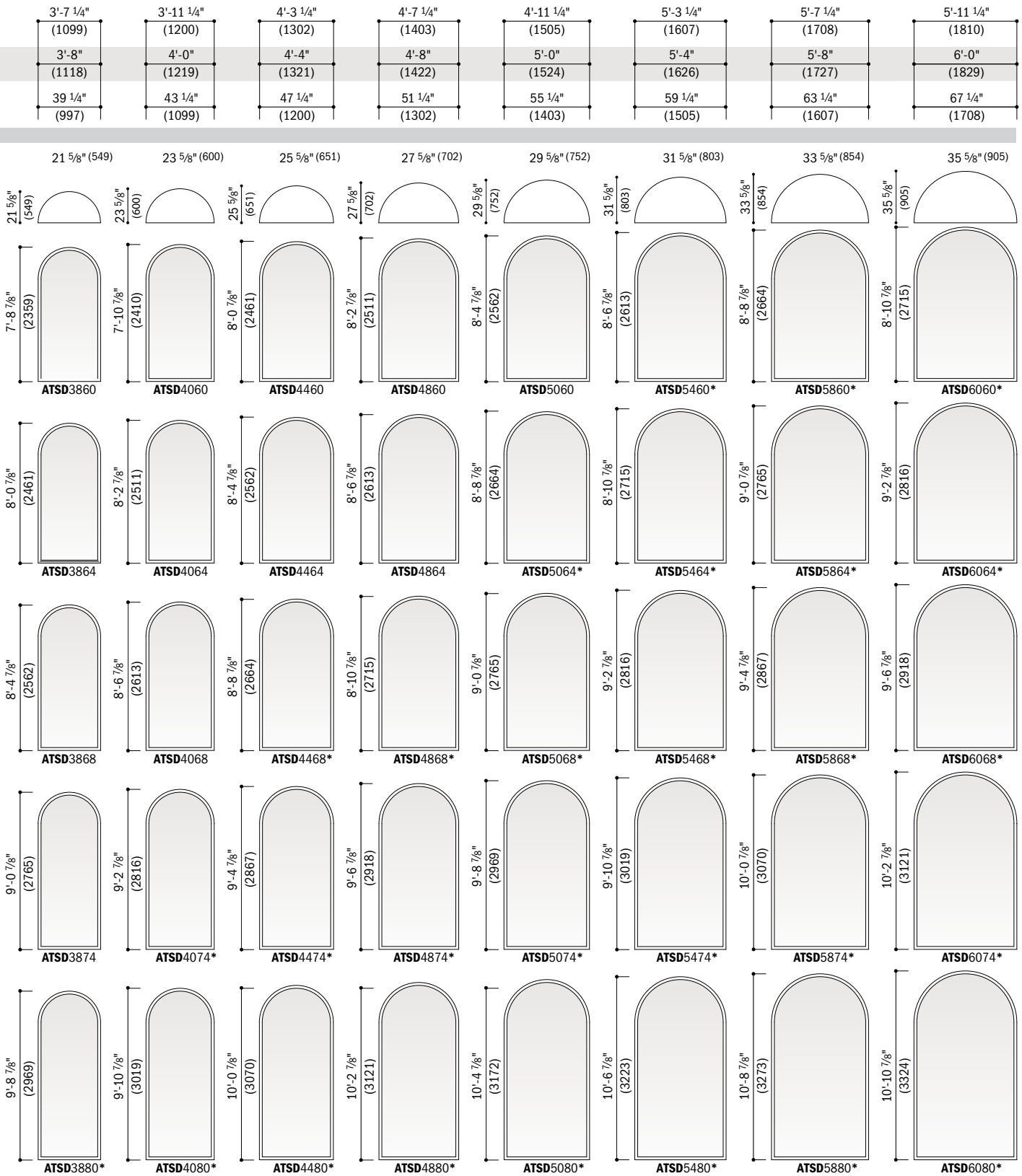

continued on next page

- *Window Dimension* always refers to outside frame-to-frame dimension.
- *Minimum Rough Opening* dimensions may need to be increased to allow for use of building wraps, flashing, sill panning, brackets, fasteners or other items. See pages 226-227 for more details.
- Dimensions in parentheses are in millimeters.
- *Tempered glass required. Some visual distortion may occur.

SPECIALTY WINDOWS

Table of Direct-Set Springline™ Window Sizes (continued)

Notes on page 106 also apply to this page.

Scale 1/8" (3) = 1'-0" (305) – 1:96

Window Width Dimension	6'-3 1/4" (1911)	6'-7 1/4" (2013)	6'-11 1/4" (2115)	7'-3 1/4" (2216)	7'-11 1/4" (2419)
Minimum Rough Opening	6'-4" (1930)	6'-8" (2032)	7'-0" (2134)	7'-4" (2235)	8'-0" (2438)
Unobstructed Glass	71 1/4" (1810)	75 1/4" (1911)	79 1/4" (2013)	83 1/4" (2115)	91 1/4" (2318)

CUSTOM SIZES AVAILABLE

Minimum Rough Opening = window height + 3/4" (19)
 Unobstructed Glass = window height - 4" (102)

CUSTOM SIZES AVAILABLE

Window height shown in table	Radius	37 5/8" (956)	39 5/8" (1006)	41 5/8" (1057)	43 5/8" (1108)	47 5/8" (1210)
Chord Height		37 5/8" (956)	39 5/8" (1006)	41 5/8" (1057)	43 5/8" (1108)	47 5/8" (1210)
Shoulder Height		6 1/4" (159)	3-9 7/8" (1165)	3-11 7/8" (1216)	4-1 7/8" (1267)	4-5 7/8" (1368)
		3-7 7/8" (1114)	4-0 7/8" (1241)	4-4 7/8" (1343)	4-6 7/8" (1394)	4-10 7/8" (1495)
		11 1/4" (286)	4-2 7/8" (1292)	4-4 7/8" (1343)	4-6 7/8" (1394)	4-10 7/8" (1495)
		23 1/4" (591)	5-2 7/8" (1597)	5-4 7/8" (1648)	5-6 7/8" (1699)	5-10 7/8" (1800)
		27 1/4" (692)	5-4 7/8" (1648)	5-8 7/8" (1749)	5-10 7/8" (1800)	6-2 7/8" (1902)
		31 1/4" (794)	5-8 7/8" (1749)	6-0 7/8" (1851)	6-2 7/8" (1902)	6-6 7/8" (2003)
		35 1/4" (895)	6-0 7/8" (1851)	6-4 7/8" (1953)	6-6 7/8" (2003)	6-10 7/8" (2105)
		39 1/4" (997)	6-4 7/8" (1953)	6-8 7/8" (2054)	6-10 7/8" (2105)	
		43 1/4" (1099)	6-8 7/8" (2054)	7-0 7/8" (2156)		
		ATSD6407	ATSD6807	ATSD7007	ATSD7407	ATSD8007
		ATSD6410	ATSD6810	ATSD7010	ATSD7410	ATSD8010
		ATSD6420	ATSD6820	ATSD7020	ATSD7420	ATSD8020*
		ATSD6424	ATSD6824	ATSD7024	ATSD7424	ATSD8024*
		ATSD6428	ATSD6828	ATSD7028	ATSD7428	ATSD8028*
		ATSD6430	ATSD6830	ATSD7030	ATSD7430*	ATSD8030*
		ATSD6434	ATSD6834	ATSD7034	ATSD7434*	
		ATSD6438	ATSD6838	ATSD7038*		

continued on page 106

* "Window Dimension" always refers to outside frame-to-frame dimension.
 * "Minimum Rough Opening" dimensions may need to be increased to allow for use of building wraps, flashing, sill panning, brackets, fasteners or other items. See pages 226-227 for more details.
 * Dimensions in parentheses are in millimeters.
 * Tempered glass required. Some visual distortion may occur.

Grille Patterns

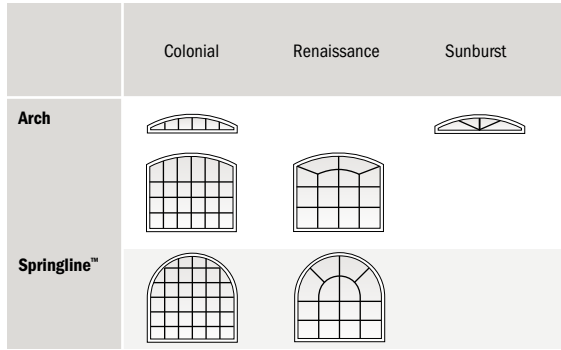

Number of lights and overall pattern varies with window size. Patterns may not be available in all configurations or sizes. Specified equal light and custom patterns are also available. For more grille options, see page 19 or visit andersenwindows.com/grilles.

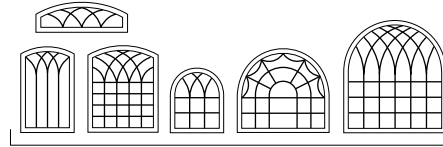

Custom Examples

**Direct-Set Springline™
Window Area Specifications**

Window Number	Glass Area Sq. Ft./ (m ²)
ATSD1807	1.08 (0.10)
ATSD1810	1.61 (0.15)
ATSD1820	2.88 (0.27)
ATSD1824	3.31 (0.31)
ATSD1828	3.73 (0.35)
ATSD1830	4.16 (0.39)
ATSD1834	4.58 (0.43)
ATSD1838	5.00 (0.46)
ATSD1840	5.43 (0.50)
ATSD1844	5.85 (0.54)
ATSD1848	6.27 (0.58)
ATSD1850	6.70 (0.62)
ATSD1854	7.12 (0.66)
ATSD1858	7.54 (0.70)
ATSD1860	7.97 (0.74)
ATSD1864	8.39 (0.78)
ATSD1868	8.82 (0.82)
ATSD1874	9.66 (0.90)
ATSD1880	10.51 (0.98)
ATSD2007	1.58 (0.15)
ATSD2010	2.25 (0.21)
ATSD2020	3.85 (0.36)
ATSD2024	4.39 (0.41)
ATSD2028	4.92 (0.46)
ATSD2030	5.46 (0.51)
ATSD2034	5.99 (0.56)
ATSD2038	6.52 (0.61)
ATSD2040	7.06 (0.66)
ATSD2044	7.59 (0.71)
ATSD2048	8.13 (0.76)
ATSD2050	8.66 (0.80)
ATSD2054	9.20 (0.85)
ATSD2058	9.73 (0.90)
ATSD2060	10.27 (0.95)
ATSD2064	10.80 (1.00)
ATSD2068	11.34 (1.05)
ATSD2074	12.41 (1.15)
ATSD2080	13.48 (1.25)
ATSD2407	2.16 (0.20)

Window Number	Glass Area Sq. Ft./ (m ²)
ATSD2410	2.97 (0.28)
ATSD2420	4.91 (0.46)
ATSD2424	5.55 (0.52)
ATSD2428	6.20 (0.58)
ATSD2430	6.84 (0.64)
ATSD2434	7.49 (0.70)
ATSD2438	8.13 (0.76)
ATSD2440	8.78 (0.82)
ATSD2444	9.43 (0.88)
ATSD2448	10.07 (0.94)
ATSD2450	10.72 (1.00)
ATSD2454	11.36 (1.06)
ATSD2458	12.01 (1.12)
ATSD2460	12.66 (1.18)
ATSD2464	13.30 (1.24)
ATSD2468	13.95 (1.30)
ATSD2474	15.24 (1.42)
ATSD2480	16.53 (1.54)
ATSD2607	2.48 (0.23)
ATSD2610	3.36 (0.31)
ATSD2620	5.46 (0.51)
ATSD2624	6.17 (0.57)
ATSD2628	6.87 (0.64)
ATSD2630	7.57 (0.70)
ATSD2634	8.27 (0.77)
ATSD2638	8.97 (0.83)
ATSD2640	9.67 (0.90)
ATSD2644	10.37 (0.96)
ATSD2648	11.08 (1.03)
ATSD2650	11.78 (1.09)
ATSD2654	12.48 (1.16)
ATSD2658	13.18 (1.22)
ATSD2660	13.88 (1.29)
ATSD2664	14.58 (1.35)
ATSD2668	15.28 (1.42)
ATSD2674	16.69 (1.55)
ATSD2680	18.09 (1.68)
ATSD2807	2.83 (0.26)
ATSD2810	3.78 (0.35)

Window Number	Glass Area Sq. Ft./ (m ²)
ATSD2820	6.05 (0.56)
ATSD2824	6.80 (0.63)
ATSD2828	7.56 (0.70)
ATSD2830	8.32 (0.77)
ATSD2834	9.07 (0.84)
ATSD2838	9.83 (0.91)
ATSD2840	10.59 (0.98)
ATSD2844	11.34 (1.05)
ATSD2848	12.10 (1.12)
ATSD2850	12.86 (1.19)
ATSD2854	13.62 (1.26)
ATSD2858	14.37 (1.34)
ATSD2860	15.13 (1.41)
ATSD2864	15.89 (1.48)
ATSD2868	16.64 (1.55)
ATSD2874	18.16 (1.69)
ATSD2880	19.67 (1.83)
ATSD21007	3.20 (0.30)
ATSD21010	4.21 (0.39)
ATSD21020	6.65 (0.62)
ATSD21024	7.46 (0.69)
ATSD21028	8.27 (0.77)
ATSD21030	9.09 (0.84)
ATSD21034	9.90 (0.92)
ATSD21038	10.71 (1.00)
ATSD21040	11.52 (1.07)
ATSD21044	12.34 (1.15)
ATSD21048	13.15 (1.22)
ATSD21050	13.96 (1.30)
ATSD21054	14.77 (1.37)
ATSD21058	15.59 (1.45)
ATSD21060	16.40 (1.52)
ATSD21064	17.21 (1.60)
ATSD21068	18.02 (1.67)
ATSD21074	19.65 (1.83)
ATSD21080	21.27 (1.98)
ATSD3007	3.59 (0.33)
ATSD3010	4.67 (0.43)
ATSD3020	7.27 (0.68)

Window Number	Glass Area Sq. Ft./ (m ²)
ATSD3024	8.14 (0.76)
ATSD3028	9.01 (0.84)
ATSD3030	9.88 (0.92)
ATSD3034	10.75 (1.00)
ATSD3038	11.61 (1.08)
ATSD3040	12.48 (1.16)
ATSD3044	13.35 (1.24)
ATSD3048	14.22 (1.32)
ATSD3050	15.09 (1.40)
ATSD3054	15.96 (1.48)
ATSD3058	16.82 (1.56)
ATSD3060	17.69 (1.64)
ATSD3064	18.56 (1.72)
ATSD3068	19.43 (1.80)
ATSD3074	21.16 (1.97)
ATSD3080	22.90 (2.13)
ATSD3207	4.00 (0.37)
ATSD3210	5.15 (0.48)
ATSD3220	7.92 (0.74)
ATSD3224	8.85 (0.82)
ATSD3228	9.77 (0.91)
ATSD3230	10.69 (0.99)
ATSD3234	11.62 (1.08)
ATSD3238	12.54 (1.16)
ATSD3240	13.46 (1.25)
ATSD3244	14.39 (1.34)
ATSD3248	15.31 (1.42)
ATSD3250	16.23 (1.51)
ATSD3254	17.16 (1.59)
ATSD3258	18.08 (1.68)
ATSD3260	19.00 (1.77)
ATSD3264	19.93 (1.85)
ATSD3268	20.85 (1.94)
ATSD3274	22.70 (2.11)
ATSD3280	24.55 (2.28)
ATSD3407	4.43 (0.41)
ATSD3410	5.65 (0.53)
ATSD3420	8.59 (0.80)

* Dimensions in parentheses are in square meters.

continued on page 107

SPECIALTY WINDOWS

Table of Direct-Set Springline™ Window Sizes (continued from page 104)

Scale 1/8" (3) = 1'-0" (305) – 1:96

Window Width Dimension	6'-3 1/4" (1911)	6'-7 1/4" (2013)	6'-11 1/4" (2115)
Minimum Rough Opening	6'-4" (1930)	6'-8" (2032)	7'-0" (2134)
Unobstructed Glass	71 1/4" (1810)	75 1/4" (1911)	79 1/4" (2013)

CUSTOM SIZES AVAILABLE				
Window height shown in table	Radius	37 5/8" (956)	39 5/8" (1006)	41 5/8" (1057)
Chord Height		37 5/8" (956)	39 5/8" (1006)	41 5/8" (1057)
Shoulder Height 47 1/4" (1200)		7'-0 7/8" (2156)	7'-2 7/8" (2207)	7'-4 7/8" (2257)
		ATSD6440	ATSD6840*	ATSD7040*
	51 1/4" (1302)	7'-4 7/8" (2257)	7'-6 7/8" (2308)	7'-8 7/8" (2359)
		ATSD6444	ATSD6844*	ATSD7044*
	55 1/4" (1403)	7'-8 7/8" (2359)	7'-10 7/8" (2410)	8'-0 7/8" (2461)
		ATSD6448*	ATSD6848*	ATSD7048*
	59 1/4" (1505)	8'-0 7/8" (2461)	8'-2 7/8" (2511)	8'-4 7/8" (2562)
		ATSD6450*	ATSD6850*	ATSD7050*
	63 1/4" (1607)	8'-4 7/8" (2562)	8'-6 7/8" (2613)	8'-8 7/8" (2664)
		ATSD6454*	ATSD6854*	ATSD7054*
67 1/4" (1708)	8'-8 7/8" (2664)	8'-10 7/8" (2715)	9'-0 7/8" (2765)	
	ATSD6458*	ATSD6858*	ATSD7058*	

Minimum Rough Opening = window height + 3/4" (19)
Unobstructed Glass = window height - 4" (102)

CUSTOM SIZES AVAILABLE



Custom-size windows are available in 1/8" (3) increments. Contact your Andersen supplier for more information.

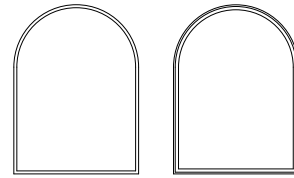

Direct-Set Springline Sash-Set Springline

Direct-set Springline (ATSD) window sizes shown. Use window dimensions and minimum rough opening formula shown for sash-set Springline (ATS) window sizes. For sash-set unobstructed glass dimensions, see pages 108-110.

All sizes shown, along with custom sizes, are available with PG upgrade.

Grille patterns shown on page 105.

Details shown on page 111.

*"Window Dimension" always refers to outside frame-to-frame dimension.
 *"Minimum Rough Opening" dimensions may need to be increased to allow for use of building wraps, flashing, sill panning, brackets, fasteners or other items. See pages 226-227 for more details.
 *Dimensions in parentheses are in millimeters.
 *Tempered glass required. Some visual distortion may occur.

continued on page 108

**Direct-Set Springline™
Window Area Specifications** *(continued from page 105)*

Window Number	Glass Area Sq. Ft./ (m ²)	Window Number	Glass Area Sq. Ft./ (m ²)	Window Number	Glass Area Sq. Ft./ (m ²)	Window Number	Glass Area Sq. Ft./ (m ²)
ATSD3424	9.57 (0.89)	ATSD4434	18.31 (1.70)	ATSD5444	29.84 (2.77)	ATSD6454	44.15 (4.10)
ATSD3428	10.55 (0.98)	ATSD4438	19.62 (1.82)	ATSD5448	31.48 (2.92)	ATSD6458	46.13 (4.29)
ATSD3430	11.53 (1.07)	ATSD4440	20.94 (1.94)	ATSD5450	33.13 (3.08)	ATSD6460	48.11 (4.47)
ATSD3434	12.51 (1.16)	ATSD4444	22.25 (2.07)	ATSD5454	34.78 (3.23)	ATSD6464	50.09 (4.65)
ATSD3438	13.49 (1.25)	ATSD4448	23.56 (2.19)	ATSD5458	36.42 (3.38)	ATSD6468	52.07 (4.84)
ATSD3440	14.47 (1.34)	ATSD4450	24.87 (2.31)	ATSD5460	38.07 (3.54)	ATSD6474	56.03 (5.20)
ATSD3444	15.44 (1.43)	ATSD4454	26.19 (2.43)	ATSD5464	39.71 (3.69)	ATSD6480	59.98 (5.57)
ATSD3448	16.42 (1.53)	ATSD4458	27.50 (2.55)	ATSD5468	41.36 (3.84)	ATSD6807	17.66 (1.64)
ATSD3450	17.40 (1.62)	ATSD4460	28.81 (2.68)	ATSD5474	44.65 (4.15)	ATSD6810	20.28 (1.88)
ATSD3454	18.38 (1.71)	ATSD4464	30.12 (2.80)	ATSD5480	47.94 (4.45)	ATSD6820	26.55 (2.47)
ATSD3458	19.36 (1.80)	ATSD4468	31.44 (2.92)	ATSD5807	12.78 (1.19)	ATSD6824	28.64 (2.66)
ATSD3460	20.34 (1.89)	ATSD4474	34.06 (3.16)	ATSD5810	14.97 (1.39)	ATSD6828	30.73 (2.85)
ATSD3464	21.32 (1.98)	ATSD4480	36.69 (3.41)	ATSD5820	20.24 (1.88)	ATSD6830	32.82 (3.05)
ATSD3468	22.30 (2.07)	ATSD4807	8.68 (0.81)	ATSD5824	22.00 (2.04)	ATSD6834	34.91 (3.24)
ATSD3474	24.26 (2.25)	ATSD4810	10.45 (0.97)	ATSD5828	23.76 (2.21)	ATSD6838	37.00 (3.44)
ATSD3480	26.22 (2.44)	ATSD4820	14.73 (1.37)	ATSD5830	25.51 (2.37)	ATSD6840	39.09 (3.63)
ATSD3807	5.36 (0.50)	ATSD4824	16.15 (1.50)	ATSD5834	27.27 (2.53)	ATSD6844	41.18 (3.83)
ATSD3810	6.72 (0.62)	ATSD4828	17.57 (1.63)	ATSD5838	29.03 (2.70)	ATSD6848	43.27 (4.02)
ATSD3820	9.99 (0.93)	ATSD4830	19.00 (1.76)	ATSD5840	30.79 (2.86)	ATSD6850	45.36 (4.21)
ATSD3824	11.08 (1.03)	ATSD4834	20.42 (1.90)	ATSD5844	32.54 (3.02)	ATSD6854	47.45 (4.41)
ATSD3828	12.17 (1.13)	ATSD4838	21.84 (2.03)	ATSD5848	34.30 (3.19)	ATSD6858	49.54 (4.60)
ATSD3830	13.26 (1.23)	ATSD4840	23.27 (2.16)	ATSD5850	36.06 (3.35)	ATSD6860	51.63 (4.80)
ATSD3834	14.35 (1.33)	ATSD4844	24.69 (2.29)	ATSD5854	37.81 (3.51)	ATSD6864	53.72 (4.99)
ATSD3838	15.44 (1.43)	ATSD4848	26.11 (2.43)	ATSD5858	39.57 (3.68)	ATSD6868	55.81 (5.18)
ATSD3840	16.53 (1.54)	ATSD4850	27.54 (2.56)	ATSD5860	41.33 (3.84)	ATSD6874	59.99 (5.57)
ATSD3844	17.63 (1.64)	ATSD4854	28.96 (2.69)	ATSD5864	43.08 (4.00)	ATSD6880	64.17 (5.96)
ATSD3848	18.72 (1.74)	ATSD4858	30.39 (2.82)	ATSD5868	44.84 (4.17)	ATSD7007	19.47 (1.81)
ATSD3850	19.81 (1.84)	ATSD4860	31.81 (2.96)	ATSD5874	48.35 (4.49)	ATSD7010	22.22 (2.06)
ATSD3854	20.90 (1.94)	ATSD4864	33.23 (3.09)	ATSD5880	51.87 (4.82)	ATSD7020	28.82 (2.68)
ATSD3858	21.99 (2.04)	ATSD4868	34.66 (3.22)	ATSD6007	14.32 (1.33)	ATSD7024	31.02 (2.88)
ATSD3860	23.08 (2.14)	ATSD4874	37.50 (3.48)	ATSD6010	16.65 (1.55)	ATSD7028	33.23 (3.09)
ATSD3864	24.17 (2.25)	ATSD4880	40.35 (3.75)	ATSD6020	22.26 (2.07)	ATSD7030	35.43 (3.29)
ATSD3868	25.26 (2.35)	ATSD5007	9.96 (0.92)	ATSD6024	24.13 (2.24)	ATSD7034	37.63 (3.50)
ATSD3874	27.44 (2.55)	ATSD5010	11.87 (1.10)	ATSD6028	25.99 (2.41)	ATSD7038	39.83 (3.70)
ATSD3880	29.62 (2.75)	ATSD5020	16.48 (1.53)	ATSD6030	27.86 (2.59)	ATSD7040	42.03 (3.90)
ATSD4007	6.38 (0.59)	ATSD5024	18.01 (1.67)	ATSD6034	29.73 (2.76)	ATSD7044	44.23 (4.11)
ATSD4010	7.88 (0.73)	ATSD5028	19.55 (1.82)	ATSD6038	31.60 (2.94)	ATSD7048	46.43 (4.31)
ATSD4020	11.48 (1.07)	ATSD5030	21.08 (1.96)	ATSD6040	33.47 (3.11)	ATSD7050	48.63 (4.52)
ATSD4024	12.68 (1.18)	ATSD5034	22.62 (2.10)	ATSD6044	35.33 (3.28)	ATSD7054	50.84 (4.72)
ATSD4028	13.89 (1.29)	ATSD5038	24.15 (2.24)	ATSD6048	37.20 (3.46)	ATSD7058	53.04 (4.93)
ATSD4030	15.09 (1.40)	ATSD5040	25.69 (2.39)	ATSD6050	39.07 (3.63)	ATSD7060	55.24 (5.13)
ATSD4034	16.29 (1.51)	ATSD5044	27.22 (2.53)	ATSD6054	40.94 (3.80)	ATSD7064	57.44 (5.34)
ATSD4038	17.49 (1.62)	ATSD5048	28.76 (2.67)	ATSD6058	42.81 (3.98)	ATSD7068	59.64 (5.54)
ATSD4040	18.69 (1.74)	ATSD5050	30.29 (2.81)	ATSD6060	44.67 (4.15)	ATSD7074	64.04 (5.95)
ATSD4044	19.89 (1.85)	ATSD5054	31.83 (2.96)	ATSD6064	46.54 (4.32)	ATSD7080	68.45 (6.36)
ATSD4048	21.09 (1.96)	ATSD5058	33.36 (3.10)	ATSD6068	48.41 (4.50)	ATSD7407	21.36 (1.98)
ATSD4050	22.30 (2.07)	ATSD5060	34.89 (3.24)	ATSD6074	52.15 (4.84)	ATSD7410	24.25 (2.25)
ATSD4054	23.50 (2.18)	ATSD5064	36.43 (3.38)	ATSD6080	55.88 (5.19)	ATSD7420	31.19 (2.90)
ATSD4058	24.70 (2.29)	ATSD5068	37.96 (3.53)	ATSD6407	15.95 (1.48)	ATSD7424	33.50 (3.11)
ATSD4060	25.90 (2.41)	ATSD5074	41.03 (3.81)	ATSD6410	18.42 (1.71)	ATSD7428	35.81 (3.33)
ATSD4064	27.10 (2.52)	ATSD5080	44.10 (4.10)	ATSD6420	24.36 (2.26)	ATSD7430	38.12 (3.54)
ATSD4068	28.30 (2.63)	ATSD5407	11.32 (1.05)	ATSD6424	26.34 (2.45)	ATSD7434	40.44 (3.76)
ATSD4074	30.71 (2.85)	ATSD5410	13.38 (1.24)	ATSD6428	28.32 (2.63)	ATSD8007	25.40 (2.36)
ATSD4080	33.11 (3.08)	ATSD5420	18.32 (1.70)	ATSD6430	30.30 (2.81)	ATSD8010	28.57 (2.65)
ATSD4407	7.48 (0.70)	ATSD5424	19.96 (1.85)	ATSD6434	32.28 (3.00)	ATSD8020	36.17 (3.36)
ATSD4410	9.12 (0.85)	ATSD5428	21.61 (2.01)	ATSD6438	34.25 (3.18)	ATSD8024	38.71 (3.60)
ATSD4420	13.06 (1.21)	ATSD5430	23.25 (2.16)	ATSD6440	36.23 (3.37)	ATSD8028	41.24 (3.83)
ATSD4424	14.37 (1.34)	ATSD5434	24.90 (2.31)	ATSD6444	38.21 (3.55)	ATSD8030	43.78 (4.07)
ATSD4428	15.69 (1.46)	ATSD5438	26.55 (2.47)	ATSD6448	40.19 (3.73)		
ATSD4430	17.00 (1.58)	ATSD5440	28.19 (2.62)	ATSD6450	42.17 (3.92)		

* Dimensions in parentheses are in square meters.

SPECIALTY WINDOWS

Table of Direct-Set Springline™ Window Sizes

Scale 1/8" (3) = 1'-0" (305) – 1:96 (continued from page 106)

Notes on page 106 also apply to this page.

Sash-Set Springline™ Window Unobstructed Glass Dimensions and Area Specifications

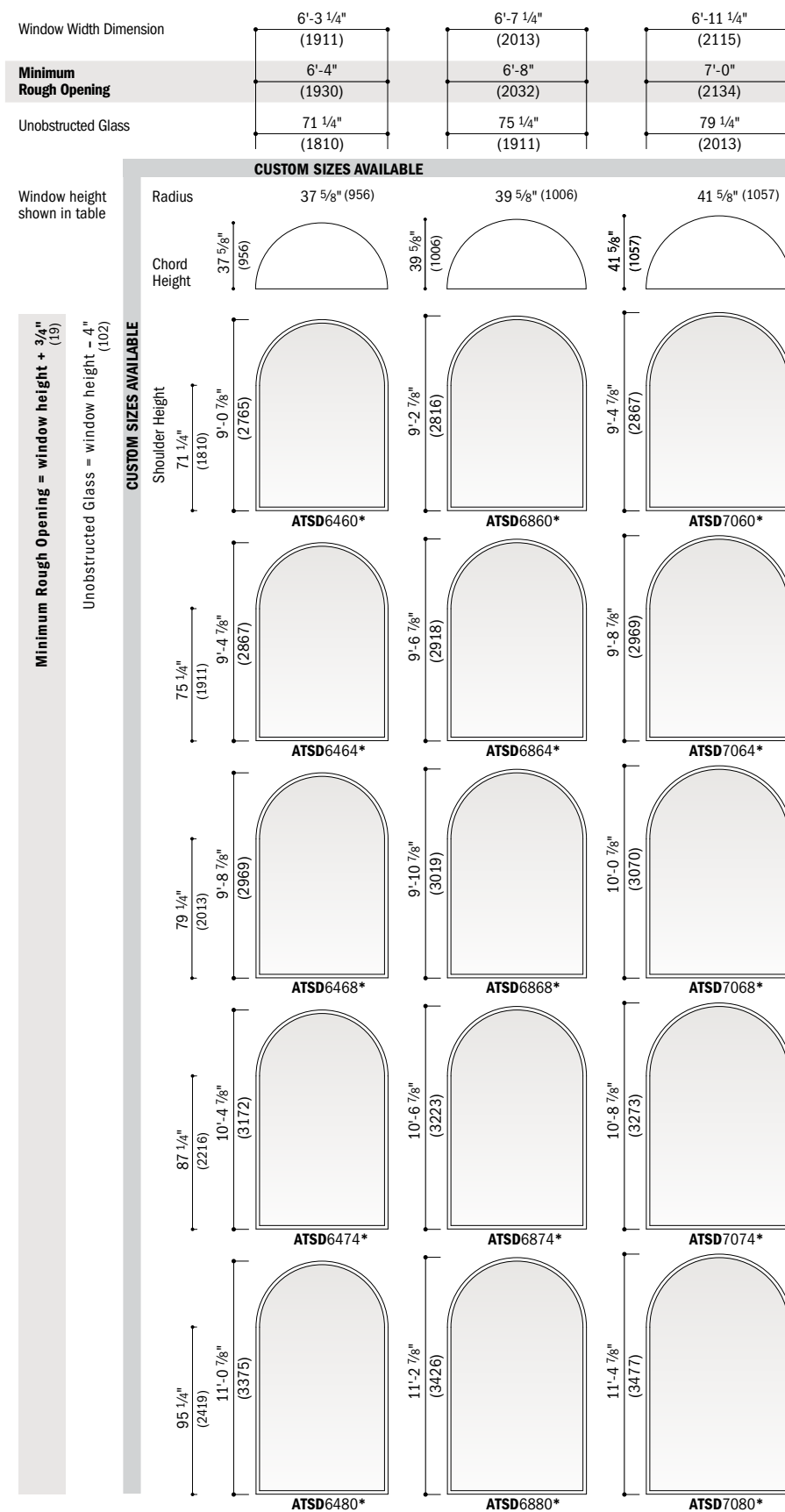

Window Number	Unobstructed Glass Width Inches/(mm)	Unobstructed Glass Height Inches/(mm)	Glass Area Sq. Ft./ (m ²)
ATS1807	12 5/8" (320)	9 1/4" (234)	0.69 (0.06)
ATS1810	12 5/8" (320)	14 1/4" (361)	1.13 (0.10)
ATS1820	12 5/8" (320)	26 1/4" (666)	2.17 (0.20)
ATS1824	12 5/8" (320)	30 1/4" (768)	2.52 (0.23)
ATS1828	12 5/8" (320)	34 1/4" (869)	2.87 (0.27)
ATS1830	12 5/8" (320)	38 1/4" (971)	3.22 (0.30)
ATS1834	12 5/8" (320)	42 1/4" (1072)	3.57 (0.33)
ATS1838	12 5/8" (320)	46 1/4" (1174)	3.92 (0.36)
ATS1840	12 5/8" (320)	50 1/4" (1276)	4.27 (0.40)
ATS1844	12 5/8" (320)	54 1/4" (1377)	4.62 (0.43)
ATS1848	12 5/8" (320)	58 1/4" (1479)	4.97 (0.46)
ATS1850	12 5/8" (320)	62 1/4" (1580)	5.32 (0.49)
ATS1854	12 5/8" (320)	66 1/4" (1682)	5.67 (0.53)
ATS1858	12 5/8" (320)	70 1/4" (1784)	6.02 (0.56)
ATS1860	12 5/8" (320)	74 1/4" (1885)	6.37 (0.59)
ATS1864	12 5/8" (320)	78 1/4" (1987)	6.72 (0.62)
ATS1868	12 5/8" (320)	82 1/4" (2088)	7.07 (0.66)
ATS1874	12 5/8" (320)	90 1/4" (2292)	7.77 (0.72)
ATS1880	12 5/8" (320)	98 1/4" (2495)	8.47 (0.79)
ATS2007	16 5/8" (421)	11 1/4" (285)	1.09 (0.10)
ATS2010	16 5/8" (421)	16 1/4" (412)	1.66 (0.15)
ATS2020	16 5/8" (421)	28 1/4" (717)	3.05 (0.28)
ATS2024	16 5/8" (421)	32 1/4" (818)	3.51 (0.33)
ATS2028	16 5/8" (421)	36 1/4" (920)	3.97 (0.37)
ATS2030	16 5/8" (421)	40 1/4" (1022)	4.43 (0.41)
ATS2034	16 5/8" (421)	44 1/4" (1123)	4.89 (0.45)
ATS2038	16 5/8" (421)	48 1/4" (1225)	5.35 (0.50)
ATS2040	16 5/8" (421)	52 1/4" (1326)	5.81 (0.54)
ATS2044	16 5/8" (421)	56 1/4" (1428)	6.27 (0.58)
ATS2048	16 5/8" (421)	60 1/4" (1530)	6.73 (0.63)
ATS2050	16 5/8" (421)	64 1/4" (1631)	7.20 (0.67)
ATS2054	16 5/8" (421)	68 1/4" (1733)	7.66 (0.71)
ATS2058	16 5/8" (421)	72 1/4" (1834)	8.12 (0.75)
ATS2060	16 5/8" (421)	76 1/4" (1936)	8.58 (0.80)
ATS2064	16 5/8" (421)	80 1/4" (2038)	9.04 (0.84)
ATS2068	16 5/8" (421)	84 1/4" (2139)	9.50 (0.88)
ATS2074	16 5/8" (421)	92 1/4" (2342)	10.42 (0.97)
ATS2080	16 5/8" (421)	100 1/4" (2546)	11.34 (1.05)
ATS2407	20 5/8" (523)	13 1/4" (336)	1.57 (0.15)
ATS2410	20 5/8" (523)	18 1/4" (463)	2.29 (0.21)
ATS2420	20 5/8" (523)	30 1/4" (768)	4.01 (0.37)
ATS2424	20 5/8" (523)	34 1/4" (869)	4.58 (0.43)
ATS2428	20 5/8" (523)	38 1/4" (971)	5.15 (0.48)
ATS2430	20 5/8" (523)	42 1/4" (1072)	5.72 (0.53)
ATS2434	20 5/8" (523)	46 1/4" (1174)	6.29 (0.58)
ATS2438	20 5/8" (523)	50 1/4" (1276)	6.87 (0.64)
ATS2440	20 5/8" (523)	54 1/4" (1377)	7.44 (0.69)
ATS2444	20 5/8" (523)	58 1/4" (1479)	8.01 (0.74)
ATS2448	20 5/8" (523)	62 1/4" (1580)	8.58 (0.80)
ATS2450	20 5/8" (523)	66 1/4" (1682)	9.15 (0.85)
ATS2454	20 5/8" (523)	70 1/4" (1784)	9.73 (0.90)
ATS2458	20 5/8" (523)	74 1/4" (1885)	10.30 (0.96)
ATS2460	20 5/8" (523)	78 1/4" (1987)	10.87 (1.01)
ATS2464	20 5/8" (523)	82 1/4" (2088)	11.44 (1.06)
ATS2468	20 5/8" (523)	86 1/4" (2190)	12.01 (1.12)
ATS2474	20 5/8" (523)	94 1/4" (2393)	13.16 (1.22)
ATS2480	20 5/8" (523)	102 1/4" (2596)	14.30 (1.33)
ATS2607	22 5/8" (574)	14 1/4" (361)	1.85 (0.17)
ATS2610	22 5/8" (574)	19 1/4" (488)	2.64 (0.24)

* Dimensions in parentheses are in millimeters or square meters.

continued on next page

Sash-Set Springline™ Window Unobstructed Glass Dimensions and Area Specifications *(continued)*

Window Number	Unobstructed Glass		Glass Area Sq. Ft./ (m ²)	Window Number	Unobstructed Glass		Glass Area Sq. Ft./ (m ²)	Window Number	Unobstructed Glass		Glass Area Sq. Ft./ (m ²)
	Width Inches/(mm)	Height Inches/(mm)			Width Inches/(mm)	Height Inches/(mm)			Width Inches/(mm)	Height Inches/(mm)	
ATS2620	22 5/8" (574)	31 1/4" (793)	4.52 (0.42)	ATS3030	28 5/8" (726)	46 1/4" (1174)	8.57 (0.80)	ATS3840	36 5/8" (929)	62 1/4" (1580)	14.81 (1.38)
ATS2624	22 5/8" (574)	35 1/4" (895)	5.15 (0.48)	ATS3034	28 5/8" (726)	50 1/4" (1276)	9.36 (0.87)	ATS3844	36 5/8" (929)	66 1/4" (1682)	15.83 (1.47)
ATS2628	22 5/8" (574)	39 1/4" (996)	5.77 (0.54)	ATS3038	28 5/8" (726)	54 1/4" (1377)	10.16 (0.94)	ATS3848	36 5/8" (929)	70 1/4" (1784)	16.85 (1.57)
ATS2630	22 5/8" (574)	43 1/4" (1098)	6.40 (0.59)	ATS3040	28 5/8" (726)	58 1/4" (1479)	10.95 (1.02)	ATS3850	36 5/8" (929)	74 1/4" (1885)	17.86 (1.66)
ATS2634	22 5/8" (574)	47 1/4" (1199)	7.03 (0.65)	ATS3044	28 5/8" (726)	62 1/4" (1580)	11.75 (1.09)	ATS3854	36 5/8" (929)	78 1/4" (1987)	18.88 (1.75)
ATS2638	22 5/8" (574)	51 1/4" (1301)	7.66 (0.71)	ATS3048	28 5/8" (726)	66 1/4" (1682)	12.54 (1.16)	ATS3858	36 5/8" (929)	82 1/4" (2088)	19.90 (1.85)
ATS2640	22 5/8" (574)	55 1/4" (1403)	8.28 (0.77)	ATS3050	28 5/8" (726)	70 1/4" (1784)	13.33 (1.24)	ATS3860	36 5/8" (929)	86 1/4" (2190)	20.91 (1.94)
ATS2644	22 5/8" (574)	59 1/4" (1504)	8.91 (0.83)	ATS3054	28 5/8" (726)	74 1/4" (1885)	14.13 (1.31)	ATS3864	36 5/8" (929)	90 1/4" (2292)	21.93 (2.04)
ATS2648	22 5/8" (574)	63 1/4" (1606)	9.54 (0.89)	ATS3058	28 5/8" (726)	78 1/4" (1987)	14.92 (1.39)	ATS3868	36 5/8" (929)	94 1/4" (2393)	22.95 (2.13)
ATS2650	22 5/8" (574)	67 1/4" (1707)	10.17 (0.94)	ATS3060	28 5/8" (726)	82 1/4" (2088)	15.72 (1.46)	ATS3874	36 5/8" (929)	102 1/4" (2596)	24.98 (2.32)
ATS2654	22 5/8" (574)	71 1/4" (1809)	10.79 (1.00)	ATS3064	28 5/8" (726)	86 1/4" (2190)	16.51 (1.53)	ATS3880	36 5/8" (929)	110 1/4" (2800)	27.01 (2.51)
ATS2658	22 5/8" (574)	75 1/4" (1911)	11.42 (1.06)	ATS3068	28 5/8" (726)	90 1/4" (2292)	17.31 (1.61)	ATS4007	40 5/8" (1031)	23 1/4" (590)	5.32 (0.49)
ATS2660	22 5/8" (574)	79 1/4" (2012)	12.05 (1.12)	ATS3074	28 5/8" (726)	98 1/4" (2495)	18.89 (1.76)	ATS4010	40 5/8" (1031)	28 1/4" (717)	6.73 (0.62)
ATS2664	22 5/8" (574)	83 1/4" (2114)	12.68 (1.18)	ATS3080	28 5/8" (726)	106 1/4" (2698)	20.48 (1.90)	ATS4020	40 5/8" (1031)	40 1/4" (1022)	10.11 (0.94)
ATS2668	22 5/8" (574)	87 1/4" (2215)	13.30 (1.24)	ATS3207	30 5/8" (777)	18 1/4" (463)	3.17 (0.29)	ATS4024	40 5/8" (1031)	44 1/4" (1123)	11.24 (1.04)
ATS2674	22 5/8" (574)	95 1/4" (2419)	14.56 (1.35)	ATS3210	30 5/8" (777)	23 1/4" (590)	4.24 (0.39)	ATS4028	40 5/8" (1031)	48 1/4" (1225)	12.37 (1.15)
ATS2680	22 5/8" (574)	103 1/4" (2622)	15.81 (1.47)	ATS3220	30 5/8" (777)	35 1/4" (895)	6.79 (0.63)	ATS4030	40 5/8" (1031)	52 1/4" (1326)	13.49 (1.25)
ATS2807	24 5/8" (625)	15 1/4" (387)	2.15 (0.20)	ATS3224	30 5/8" (777)	39 1/4" (996)	7.63 (0.71)	ATS4034	40 5/8" (1031)	56 1/4" (1428)	14.62 (1.36)
ATS2810	24 5/8" (625)	20 1/4" (514)	3.00 (0.28)	ATS3228	30 5/8" (777)	43 1/4" (1098)	8.48 (0.79)	ATS4038	40 5/8" (1031)	60 1/4" (1530)	15.75 (1.46)
ATS2820	24 5/8" (625)	32 1/4" (818)	5.05 (0.47)	ATS3230	30 5/8" (777)	47 1/4" (1199)	9.33 (0.87)	ATS4040	40 5/8" (1031)	64 1/4" (1631)	16.88 (1.57)
ATS2824	24 5/8" (625)	36 1/4" (920)	5.74 (0.53)	ATS3234	30 5/8" (777)	51 1/4" (1301)	10.18 (0.95)	ATS4044	40 5/8" (1031)	68 1/4" (1733)	18.00 (1.67)
ATS2828	24 5/8" (625)	40 1/4" (1022)	6.42 (0.60)	ATS3238	30 5/8" (777)	55 1/4" (1403)	11.03 (1.03)	ATS4048	40 5/8" (1031)	72 1/4" (1834)	19.13 (1.78)
ATS2830	24 5/8" (625)	44 1/4" (1123)	7.10 (0.66)	ATS3240	30 5/8" (777)	59 1/4" (1504)	11.88 (1.10)	ATS4050	40 5/8" (1031)	76 1/4" (1936)	20.26 (1.88)
ATS2834	24 5/8" (625)	48 1/4" (1225)	7.78 (0.72)	ATS3244	30 5/8" (777)	63 1/4" (1606)	12.73 (1.18)	ATS4054	40 5/8" (1031)	80 1/4" (2038)	21.39 (1.99)
ATS2838	24 5/8" (625)	52 1/4" (1326)	8.47 (0.79)	ATS3248	30 5/8" (777)	67 1/4" (1707)	13.58 (1.26)	ATS4058	40 5/8" (1031)	84 1/4" (2139)	22.51 (2.09)
ATS2840	24 5/8" (625)	56 1/4" (1428)	9.15 (0.85)	ATS3250	30 5/8" (777)	71 1/4" (1809)	14.43 (1.34)	ATS4060	40 5/8" (1031)	88 1/4" (2241)	23.64 (2.20)
ATS2844	24 5/8" (625)	60 1/4" (1530)	9.83 (0.91)	ATS3254	30 5/8" (777)	75 1/4" (1911)	15.28 (1.42)	ATS4064	40 5/8" (1031)	92 1/4" (2342)	24.77 (2.30)
ATS2848	24 5/8" (625)	64 1/4" (1631)	10.52 (0.98)	ATS3258	30 5/8" (777)	79 1/4" (2012)	16.13 (1.50)	ATS4068	40 5/8" (1031)	96 1/4" (2444)	25.90 (2.41)
ATS2850	24 5/8" (625)	68 1/4" (1733)	11.20 (1.04)	ATS3260	30 5/8" (777)	83 1/4" (2114)	16.98 (1.58)	ATS4074	40 5/8" (1031)	104 1/4" (2647)	28.15 (2.62)
ATS2854	24 5/8" (625)	72 1/4" (1834)	11.88 (1.10)	ATS3264	30 5/8" (777)	87 1/4" (2215)	17.83 (1.66)	ATS4080	40 5/8" (1031)	112 1/4" (2850)	30.41 (2.82)
ATS2858	24 5/8" (625)	76 1/4" (1936)	12.57 (1.17)	ATS3268	30 5/8" (777)	91 1/4" (2317)	18.68 (1.74)	ATS4407	44 5/8" (1133)	25 1/4" (641)	6.33 (0.59)
ATS2860	24 5/8" (625)	80 1/4" (2038)	13.25 (1.23)	ATS3274	30 5/8" (777)	99 1/4" (2520)	20.38 (1.89)	ATS4410	44 5/8" (1133)	30 1/4" (768)	7.88 (0.73)
ATS2864	24 5/8" (625)	84 1/4" (2139)	13.93 (1.29)	ATS3280	30 5/8" (777)	107 1/4" (2723)	22.08 (2.05)	ATS4420	44 5/8" (1133)	42 1/4" (1072)	11.59 (1.08)
ATS2868	24 5/8" (625)	88 1/4" (2241)	14.62 (1.36)	ATS3407	32 5/8" (828)	19 1/4" (488)	3.56 (0.33)	ATS4424	44 5/8" (1133)	46 1/4" (1174)	12.83 (1.19)
ATS2874	24 5/8" (625)	96 1/4" (2444)	15.98 (1.48)	ATS3410	32 5/8" (828)	24 1/4" (615)	4.69 (0.44)	ATS4428	44 5/8" (1133)	50 1/4" (1276)	14.07 (1.31)
ATS2880	24 5/8" (625)	104 1/4" (2647)	17.35 (1.61)	ATS3420	32 5/8" (828)	36 1/4" (920)	7.41 (0.69)	ATS4430	44 5/8" (1133)	54 1/4" (1377)	15.31 (1.42)
ATS21007	26 5/8" (675)	16 1/4" (412)	2.47 (0.23)	ATS3424	32 5/8" (828)	40 1/4" (1022)	8.31 (0.77)	ATS4434	44 5/8" (1133)	58 1/4" (1479)	16.55 (1.54)
ATS21010	26 5/8" (675)	21 1/4" (539)	3.39 (0.32)	ATS3428	32 5/8" (828)	44 1/4" (1123)	9.22 (0.86)	ATS4438	44 5/8" (1133)	62 1/4" (1580)	17.79 (1.65)
ATS21020	26 5/8" (675)	33 1/4" (844)	5.61 (0.52)	ATS3430	32 5/8" (828)	48 1/4" (1225)	10.12 (0.94)	ATS4440	44 5/8" (1133)	66 1/4" (1682)	19.02 (1.77)
ATS21024	26 5/8" (675)	37 1/4" (945)	6.35 (0.59)	ATS3434	32 5/8" (828)	52 1/4" (1326)	11.03 (1.02)	ATS4444	44 5/8" (1133)	70 1/4" (1784)	20.26 (1.88)
ATS21028	26 5/8" (675)	41 1/4" (1047)	7.09 (0.66)	ATS3438	32 5/8" (828)	56 1/4" (1428)	11.93 (1.11)	ATS4448	44 5/8" (1133)	74 1/4" (1885)	21.50 (2.00)
ATS21030	26 5/8" (675)	45 1/4" (1149)	7.82 (0.73)	ATS3440	32 5/8" (828)	60 1/4" (1530)	12.84 (1.19)	ATS4450	44 5/8" (1133)	78 1/4" (1987)	22.74 (2.11)
ATS21034	26 5/8" (675)	49 1/4" (1250)	8.56 (0.80)	ATS3444	32 5/8" (828)	64 1/4" (1631)	13.74 (1.28)	ATS4454	44 5/8" (1133)	82 1/4" (2088)	23.98 (2.23)
ATS21038	26 5/8" (675)	53 1/4" (1352)	9.30 (0.86)	ATS3448	32 5/8" (828)	68 1/4" (1733)	14.65 (1.36)	ATS4458	44 5/8" (1133)	86 1/4" (2190)	25.22 (2.34)
ATS21040	26 5/8" (675)	57 1/4" (1453)	10.04 (0.93)	ATS3450	32 5/8" (828)	72 1/4" (1834)	15.55 (1.45)	ATS4460	44 5/8" (1133)	90 1/4" (2292)	26.46 (2.46)
ATS21044	26 5/8" (675)	61 1/4" (1555)	10.78 (1.00)	ATS3454	32 5/8" (828)	76 1/4" (1936)	16.46 (1.53)	ATS4464	44 5/8" (1133)	94 1/4" (2393)	27.70 (2.57)
ATS21048	26 5/8" (675)	65 1/4" (1657)	11.52 (1.07)	ATS3458	32 5/8" (828)	80 1/4" (2038)	17.37 (1.61)	ATS4468	44 5/8" (1133)	98 1/4" (2495)	28.93 (2.69)
ATS21050	26 5/8" (675)	69 1/4" (1758)	12.26 (1.14)	ATS3460	32 5/8" (828)	84 1/4" (2139)	18.27 (1.70)	ATS4474	44 5/8" (1133)	106 1/4" (2698)	31.41 (2.92)
ATS21054	26 5/8" (675)	73 1/4" (1860)	13.00 (1.21)	ATS3464	32 5/8" (828)	88 1/4" (2241)	19.18 (1.78)	ATS4480	44 5/8" (1133)	114 1/4" (2901)	33.89 (3.15)
ATS21058	26 5/8" (675)	77 1/4" (1961)	13.73 (1.28)	ATS3468	32 5/8" (828)	92 1/4" (2342)	20.08 (1.87)	ATS4807	48 5/8" (1234)	27 1/4" (691)	7.43 (0.69)
ATS21060	26 5/8" (675)	81 1/4" (2063)	14.47 (1.34)	ATS3474	32 5/8" (828)	100 1/4" (2546)	21.89 (2.03)	ATS4810	48 5/8" (1234)	32 1/4" (818)	9.11 (0.85)
ATS21064	26 5/8" (675)	85 1/4" (2165)	15.21 (1.41)	ATS3480	32 5/8" (828)	108 1/4" (2749)	23.70 (2.20)	ATS4820	48 5/8" (1234)	44 1/4" (1123)	13.16 (1.22)
ATS21068	26 5/8" (675)	89 1/4" (2266)	15.95 (1.48)	ATS3807	36 5/8" (929)	21 1/4" (539)	4.39 (0.41)	ATS4824	48 5/8" (1234)	48 1/4" (1225)	14.51 (1.35)
ATS21074	26 5/8" (675)	97 1/4" (2469)	17.43 (1.62)	ATS3810	36 5/8" (929)	26 1/4" (666)	5.67 (0.53)	ATS4828	48 5/8" (1234)	52 1/4" (1326)	15.86 (1.47)
ATS21080	26 5/8" (675)	105 1/4" (2673)	18.90 (1.76)	ATS3820	36 5/8" (929)	38 1/4" (971)	8.71 (0.81)	ATS4830	48 5/8" (1234)	56 1/4" (1428)	17.21 (1.60)
ATS3007	28 5/8" (726)	17 1/4" (437)	2.81 (0.26)	ATS3824	36 5/8" (929)	42 1/4" (1072)	9.73 (0.90)	ATS4834	48 5/8" (1234)	60 1/4" (1530)	18.56 (1.72)
ATS3010	28 5/8" (726)	22 1/4" (564)	3.80 (0.35)	ATS3828	36 5/8" (929)	46 1/4" (1174)	10.75 (1.00)	ATS4838	48 5/8" (1234)	64.219 (1631)	19.91 (1.85)
ATS3020	28 5/8" (726)	34 1/4" (869)	6.19 (0.57)	ATS3830	36 5/8" (929)	50 1/4" (1276)	11.76 (1.09)	ATS4840	48 5/8" (1234)	68 1/4" (1733)	21.26 (1.98)
ATS3024	28 5/8" (726)	38 1/4" (971)	6.98 (0.65)	ATS3834	36 5/8" (929)	54 1/4" (1377)	12.78 (1.19)	ATS4844	48 5/8" (1234)	72 1/4" (1834)	22.61 (2.10)
ATS3028	28 5/8" (726)	42 1/4" (1072)	7.77 (0.72)	ATS3838	36 5/8" (929)	58 1/4" (1479)	13.80 (1.28)				

*Dimensions in parentheses are in millimeters or square meters.

continued on next page

SPECIALTY WINDOWS

Sash-Set Springline™ Window Unobstructed Glass Dimensions and Area Specifications (continued)

Window Number	Unobstructed Glass Width	Unobstructed Glass Height	Glass Area Sq. Ft./ (m ²)
	Inches/(mm)	Inches/(mm)	
ATS4848	48 5/8" (1234)	76 1/4" (1936)	23.96 (2.23)
ATS4850	48 5/8" (1234)	80 1/4" (2038)	25.31 (2.35)
ATS4854	48 5/8" (1234)	84 1/4" (2139)	26.66 (2.48)
ATS4858	48 5/8" (1234)	88 1/4" (2241)	28.01 (2.60)
ATS4860	48 5/8" (1234)	92 1/4" (2342)	29.36 (2.73)
ATS4864	48 5/8" (1234)	96 1/4" (2444)	30.71 (2.85)
ATS4868	48 5/8" (1234)	100 1/4" (2546)	32.06 (2.98)
ATS4874	48 5/8" (1234)	108 1/4" (2749)	34.76 (3.23)
ATS4880	48 5/8" (1234)	116 1/4" (2952)	37.46 (3.48)
ATS5007	52 5/8" (1336)	29 1/4" (742)	8.61 (0.80)
ATS5010	52 5/8" (1336)	34 1/4" (869)	10.44 (0.97)
ATS5020	52 5/8" (1336)	46 1/4" (1174)	14.82 (1.38)
ATS5024	52 5/8" (1336)	50 1/4" (1276)	16.28 (1.51)
ATS5028	52 5/8" (1336)	54 1/4" (1377)	17.74 (1.65)
ATS5030	52 5/8" (1336)	58 1/4" (1479)	19.20 (1.78)
ATS5034	52 5/8" (1336)	62 1/4" (1580)	20.66 (1.92)
ATS5038	52 5/8" (1336)	66 1/4" (1682)	22.12 (2.06)
ATS5040	52 5/8" (1336)	70 1/4" (1784)	23.59 (2.19)
ATS5044	52 5/8" (1336)	74 1/4" (1885)	25.05 (2.33)
ATS5048	52 5/8" (1336)	78 1/4" (1987)	26.51 (2.46)
ATS5050	52 5/8" (1336)	82 1/4" (2088)	27.97 (2.60)
ATS5054	52 5/8" (1336)	86 1/4" (2190)	29.43 (2.73)
ATS5058	52 5/8" (1336)	90 1/4" (2292)	30.89 (2.87)
ATS5060	52 5/8" (1336)	94 1/4" (2393)	32.35 (3.01)
ATS5064	52 5/8" (1336)	98 1/4" (2495)	33.81 (3.14)
ATS5068	52 5/8" (1336)	102 1/4" (2596)	35.27 (3.28)
ATS5074	52 5/8" (1336)	110 1/4" (2800)	38.19 (3.55)
ATS5080	52 5/8" (1336)	118 1/4" (3003)	41.12 (3.82)
ATS5407	56 5/8" (1437)	31 1/4" (793)	9.88 (0.92)
ATS5410	56 5/8" (1437)	36 1/4" (920)	11.85 (1.10)
ATS5420	56 5/8" (1437)	48 1/4" (1225)	16.56 (1.54)
ATS5424	56 5/8" (1437)	52 1/4" (1326)	18.14 (1.68)
ATS5428	56 5/8" (1437)	56 1/4" (1428)	19.71 (1.83)
ATS5430	56 5/8" (1437)	60 1/4" (1530)	21.28 (1.98)
ATS5434	56 5/8" (1437)	64 1/4" (1631)	22.85 (2.12)
ATS5438	56 5/8" (1437)	68 1/4" (1733)	24.42 (2.27)
ATS5440	56 5/8" (1437)	72 1/4" (1834)	26.00 (2.42)
ATS5444	56 5/8" (1437)	76 1/4" (1936)	27.57 (2.56)
ATS5448	56 5/8" (1437)	80 1/4" (2038)	29.14 (2.71)
ATS5450	56 5/8" (1437)	84 1/4" (2139)	30.71 (2.85)
ATS5454	56 5/8" (1437)	88 1/4" (2241)	32.28 (3.00)
ATS5458	56 5/8" (1437)	92 1/4" (2342)	33.86 (3.15)
ATS5460	56 5/8" (1437)	96 1/4" (2444)	35.43 (3.29)
ATS5464	56 5/8" (1437)	100 1/4" (2546)	37.00 (3.44)
ATS5468	56 5/8" (1437)	104 1/4" (2647)	38.57 (3.58)
ATS5474	56 5/8" (1437)	112 1/4" (2850)	41.72 (3.88)
ATS5480	56 5/8" (1437)	120 1/4" (3054)	44.86 (4.17)
ATS5807	60 5/8" (1539)	33 1/4" (844)	11.24 (1.04)
ATS5810	60 5/8" (1539)	38 1/4" (971)	13.35 (1.24)
ATS5820	60 5/8" (1539)	50 1/4" (1276)	18.40 (1.71)
ATS5824	60 5/8" (1539)	54 1/4" (1377)	20.08 (1.87)
ATS5828	60 5/8" (1539)	58 1/4" (1479)	21.76 (2.02)
ATS5830	60 5/8" (1539)	62 1/4" (1580)	23.45 (2.18)
ATS5834	60 5/8" (1539)	66 1/4" (1682)	25.13 (2.33)
ATS5838	60 5/8" (1539)	70 1/4" (1784)	26.81 (2.49)
ATS5840	60 5/8" (1539)	74 1/4" (1885)	28.49 (2.65)
ATS5844	60 5/8" (1539)	78 1/4" (1987)	30.18 (2.80)
ATS5848	60 5/8" (1539)	82 1/4" (2088)	31.86 (2.96)
ATS5850	60 5/8" (1539)	86 1/4" (2190)	33.54 (3.12)
ATS5854	60 5/8" (1539)	90 1/4" (2292)	35.23 (3.27)

Window Number	Unobstructed Glass Width	Unobstructed Glass Height	Glass Area Sq. Ft./ (m ²)
	Inches/(mm)	Inches/(mm)	
ATS5858	60 5/8" (1539)	94 1/4" (2393)	36.91 (3.43)
ATS5860	60 5/8" (1539)	98 1/4" (2495)	38.59 (3.59)
ATS5864	60 5/8" (1539)	102 1/4" (2596)	40.28 (3.74)
ATS5868	60 5/8" (1539)	106 1/4" (2698)	41.96 (3.90)
ATS5874	60 5/8" (1539)	114 1/4" (2901)	45.33 (4.21)
ATS5880	60 5/8" (1539)	122 1/4" (3104)	48.69 (4.52)
ATS6007	64 5/8" (1641)	35 1/4" (895)	12.69 (1.18)
ATS6010	64 5/8" (1641)	40 1/4" (1022)	14.93 (1.39)
ATS6020	64 5/8" (1641)	52 1/4" (1326)	20.31 (1.89)
ATS6024	64 5/8" (1641)	56 1/4" (1428)	22.11 (2.05)
ATS6028	64 5/8" (1641)	60 1/4" (1530)	23.90 (2.22)
ATS6030	64 5/8" (1641)	64 1/4" (1631)	25.70 (2.39)
ATS6034	64 5/8" (1641)	68 1/4" (1733)	27.49 (2.55)
ATS6038	64 5/8" (1641)	72 1/4" (1834)	29.29 (2.72)
ATS6040	64 5/8" (1641)	76 1/4" (1936)	31.08 (2.89)
ATS6044	64 5/8" (1641)	80 1/4" (2038)	32.87 (3.05)
ATS6048	64 5/8" (1641)	84 1/4" (2139)	34.67 (3.22)
ATS6050	64 5/8" (1641)	88 1/4" (2241)	36.46 (3.39)
ATS6054	64 5/8" (1641)	92 1/4" (2342)	38.26 (3.55)
ATS6058	64 5/8" (1641)	96 1/4" (2444)	40.05 (3.72)
ATS6060	64 5/8" (1641)	100 1/4" (2546)	41.85 (3.89)
ATS6064	64 5/8" (1641)	104 1/4" (2647)	43.64 (4.05)
ATS6068	64 5/8" (1641)	108 1/4" (2749)	45.43 (4.22)
ATS6074	64 5/8" (1641)	116 1/4" (2952)	49.02 (4.55)
ATS6080	64 5/8" (1641)	124 1/4" (3155)	52.61 (4.89)
ATS6407	68 5/8" (1742)	37 1/4" (945)	14.22 (1.32)
ATS6410	68 5/8" (1742)	42 1/4" (1072)	16.60 (1.54)
ATS6420	68 5/8" (1742)	54 1/4" (1377)	22.32 (2.07)
ATS6424	68 5/8" (1742)	58 1/4" (1479)	24.23 (2.25)
ATS6428	68 5/8" (1742)	62 1/4" (1580)	26.13 (2.43)
ATS6430	68 5/8" (1742)	66 1/4" (1682)	28.04 (2.60)
ATS6434	68 5/8" (1742)	70 1/4" (1784)	29.94 (2.78)
ATS6438	68 5/8" (1742)	74 1/4" (1885)	31.85 (2.96)
ATS6440	68 5/8" (1742)	78 1/4" (1987)	33.75 (3.14)
ATS6444	68 5/8" (1742)	82 1/4" (2088)	35.66 (3.31)
ATS6448	68 5/8" (1742)	86 1/4" (2190)	37.56 (3.49)
ATS6450	68 5/8" (1742)	90 1/4" (2292)	39.47 (3.67)
ATS6454	68 5/8" (1742)	94 1/4" (2393)	41.37 (3.84)
ATS6458	68 5/8" (1742)	98 1/4" (2495)	43.28 (4.02)
ATS6460	68 5/8" (1742)	102 1/4" (2596)	45.19 (4.20)
ATS6464	68 5/8" (1742)	106 1/4" (2698)	47.09 (4.37)
ATS6468	68 5/8" (1742)	110 1/4" (2800)	49.00 (4.55)
ATS6474	68 5/8" (1742)	118 1/4" (3003)	52.81 (4.91)
ATS6480	68 5/8" (1742)	126 1/4" (3206)	56.62 (5.26)
ATS6807	72 5/8" (1844)	39 1/4" (996)	15.84 (1.47)
ATS6810	72 5/8" (1844)	44 1/4" (1123)	18.37 (1.71)
ATS6820	72 5/8" (1844)	56 1/4" (1428)	24.41 (2.27)
ATS6824	72 5/8" (1844)	60 1/4" (1530)	26.43 (2.46)
ATS6828	72 5/8" (1844)	64 1/4" (1631)	28.45 (2.64)
ATS6830	72 5/8" (1844)	68 1/4" (1733)	30.46 (2.83)
ATS6834	72 5/8" (1844)	72 1/4" (1834)	32.48 (3.02)
ATS6838	72 5/8" (1844)	76 1/4" (1936)	34.50 (3.20)
ATS6840	72 5/8" (1844)	80 1/4" (2038)	36.51 (3.39)
ATS6844	72 5/8" (1844)	84 1/4" (2139)	38.53 (3.58)
ATS6848	72 5/8" (1844)	88 1/4" (2241)	40.55 (3.77)
ATS6850	72 5/8" (1844)	92 1/4" (2342)	42.56 (3.95)
ATS6854	72 5/8" (1844)	96 1/4" (2444)	44.58 (4.14)
ATS6858	72 5/8" (1844)	100 1/4" (2546)	46.60 (4.33)
ATS6860	72 5/8" (1844)	104 1/4" (2647)	48.61 (4.52)
ATS6864	72 5/8" (1844)	108 1/4" (2749)	50.63 (4.70)

Window Number	Unobstructed Glass Width	Unobstructed Glass Height	Glass Area Sq. Ft./ (m ²)
	Inches/(mm)	Inches/(mm)	
ATS6868	72 5/8" (1844)	112 1/4" (2850)	52.65 (4.89)
ATS6874	72 5/8" (1844)	120 1/4" (3054)	56.68 (5.27)
ATS6880	72 5/8" (1844)	128 1/4" (3257)	60.71 (5.64)
ATS7007	76 5/8" (1945)	41 1/4" (1047)	17.55 (1.63)
ATS7010	76 5/8" (1945)	46 1/4" (1174)	20.21 (1.88)
ATS7020	76 5/8" (1945)	58 1/4" (1479)	26.60 (2.47)
ATS7024	76 5/8" (1945)	62 1/4" (1580)	28.72 (2.67)
ATS7028	76 5/8" (1945)	66 1/4" (1682)	30.85 (2.87)
ATS7030	76 5/8" (1945)	70 1/4" (1784)	32.98 (3.06)
ATS7034	76 5/8" (1945)	74 1/4" (1885)	35.11 (3.26)
ATS7038	76 5/8" (1945)	78 1/4" (1987)	37.23 (3.46)
ATS7040	76 5/8" (1945)	82 1/4" (2088)	39.36 (3.66)
ATS7044	76 5/8" (1945)	86 1/4" (2190)	41.49 (3.85)
ATS7048	76 5/8" (1945)	90 1/4" (2292)	43.62 (4.05)
ATS7050	76 5/8" (1945)	94 1/4" (2393)	45.74 (4.25)
ATS7054	76 5/8" (1945)	98 1/4" (2495)	47.87 (4.45)
ATS7058	76 5/8" (1945)	102 1/4" (2596)	50.00 (4.64)
ATS7060	76 5/8" (1945)	106 1/4" (2698)	52.13 (4.84)
ATS7064	76 5/8" (1945)	110 1/4" (2800)	54.25 (5.04)
ATS7068	76 5/8" (1945)	114 1/4" (2901)	56.38 (5.24)
ATS7074	76 5/8" (1945)	122 1/4" (3104)	60.64 (5.63)
ATS7080	76 5/8" (1945)	130 1/4" (3308)	64.89 (6.03)
ATS7407	80 5/8" (2047)	43 1/4" (1098)	19.35 (1.80)
ATS7410	80 5/8" (2047)	48 1/4" (1225)	22.15 (2.06)
ATS7420	80 5/8" (2047)	60 1/4" (1530)	28.86 (2.68)
ATS7424	80 5/8" (2047)	64 1/4" (1631)	31.10 (2.89)
ATS7428	80 5/8" (2047)	68 1/4" (1733)	33.34 (3.10)
ATS7430	80 5/8" (2047)	72 1/4" (1834)	35.58 (3.31)
ATS7434	80 5/8" (2047)	76 1/4" (1936)	37.82 (3.51)
ATS8007	88 5/8" (2250)	47 1/4" (1199)	23.20 (2.16)
ATS8010	88 5/8" (2250)	52 1/4" (1326)	26.28 (2.44)
ATS8020	88 5/8" (2250)	64 1/4" (1631)	33.66 (3.13)
ATS8024	88 5/8" (2250)	68 1/4" (1733)	36.12 (3.36)
ATS8028	88 5/8" (2250)	72 1/4" (1834)	38.58 (3.58)
ATS8030	88 5/8" (2250)	76 1/4" (1936)	41.04 (3.81)

* Dimensions in parentheses are in millimeters or square meters.

Direct-Set Specialty Window Details

Scale 1 1/2" (38) = 1'-0" (305) – 1:8

Sash-Set Specialty Window Details

Scale 1 1/2" (38) = 1'-0" (305) – 1:8

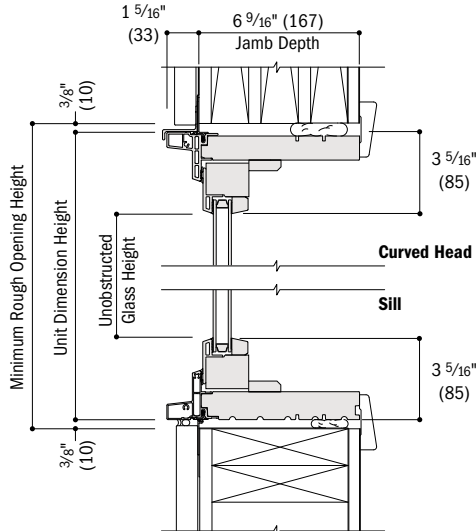
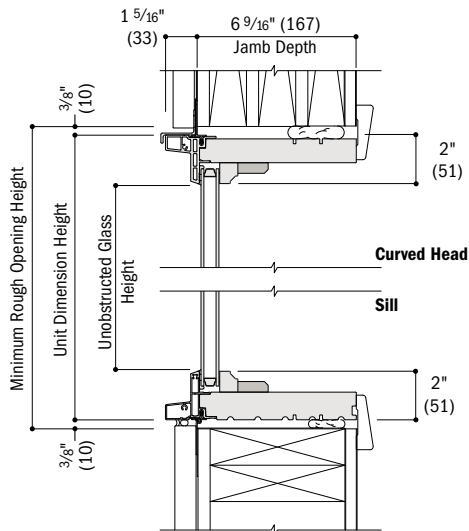
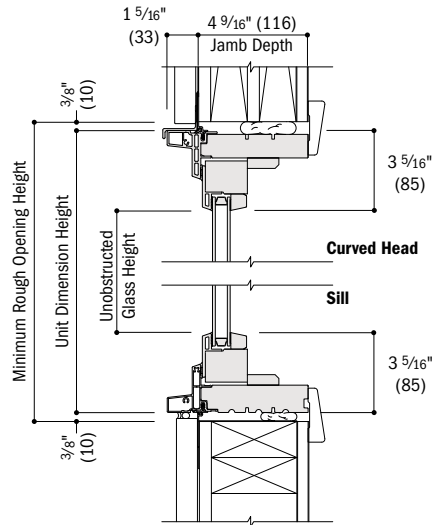
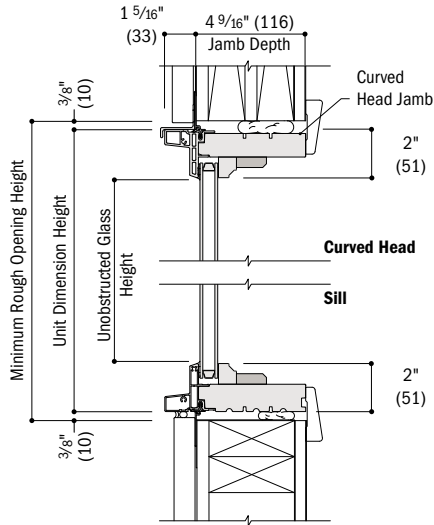
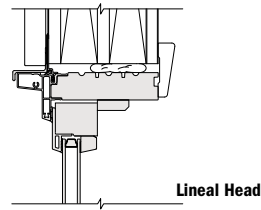
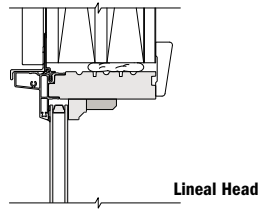

Both lineal and curved head jambs are shown. Choose detail based on your specialty window shape.

Direct-set specialty and sash-set specialty windows are available in both 4 9/16" (116) and 6 9/16" (167) base jamb depths.

Oval windows are only available direct-set.

See page 112 for joining details.

- 4 9/16" (116) and 6 9/16" (167) base jamb depth measurements are from back side of installation flange.
- Light-colored areas are parts included with window. Dark-colored areas are additional Andersen® parts required to complete window assembly as shown.
- Dimensions in parentheses are in millimeters.
- **Minimum rough openings may need to be increased to allow for use of building wraps, flashing, sill panning, brackets, fasteners or other items. See installation information on pages 226-227.**
- Details are for illustration only and are not intended to represent product installation methods or materials. Refer to product installation instructions at andersenwindows.com.

SPECIALTY WINDOWS

Horizontal (stack) Joining Details

Scale 1 1/2" (38) = 1'-0" (305) – 1:8

Windows can be joined to other windows using clip or 4 9/16" (116) fiberglass joining materials. Specialty windows can be joined over patio doors using fiberglass joining material for 4 9/16" (116) and 6 9/16" (167) base jamb depths. For factory-joined specialty-to-specialty window combinations, 4 9/16" (116) or 6 9/16" (167) Laminated veneer Lumber (LVL) joining material will be used. For additional window combinations, see pages 60-62.

Overall "Specialty Window/Window" or

"Specialty Window/Door" Dimension Height -

Sum of individual "specialty window/window" or "specialty window/door" heights plus 3/4" (19) per join.

Overall Minimum Rough Opening Height -

Overall dimension height plus 3/4" (19).

For more information on joining, refer to the combination designs section starting on page 196.

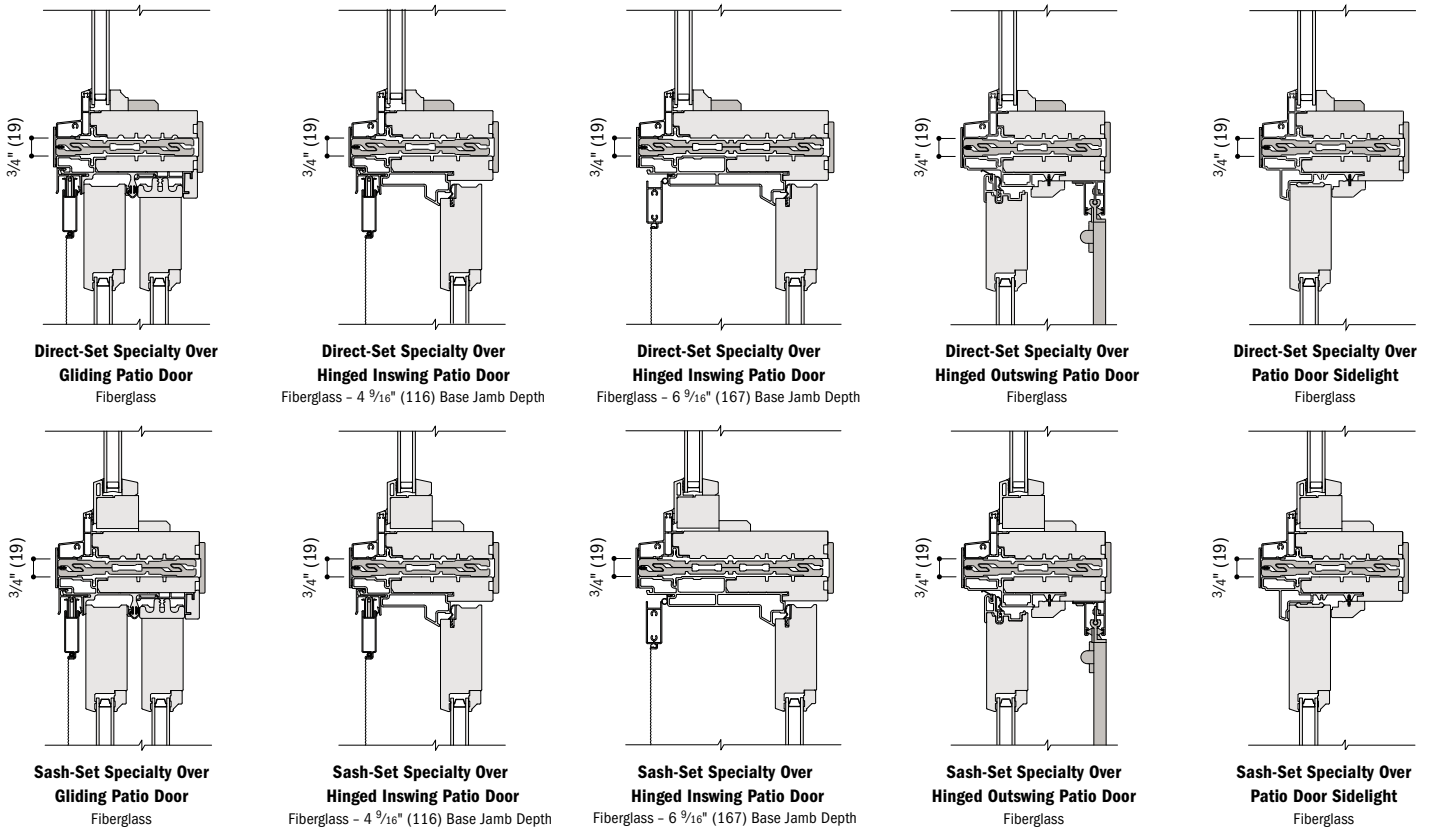
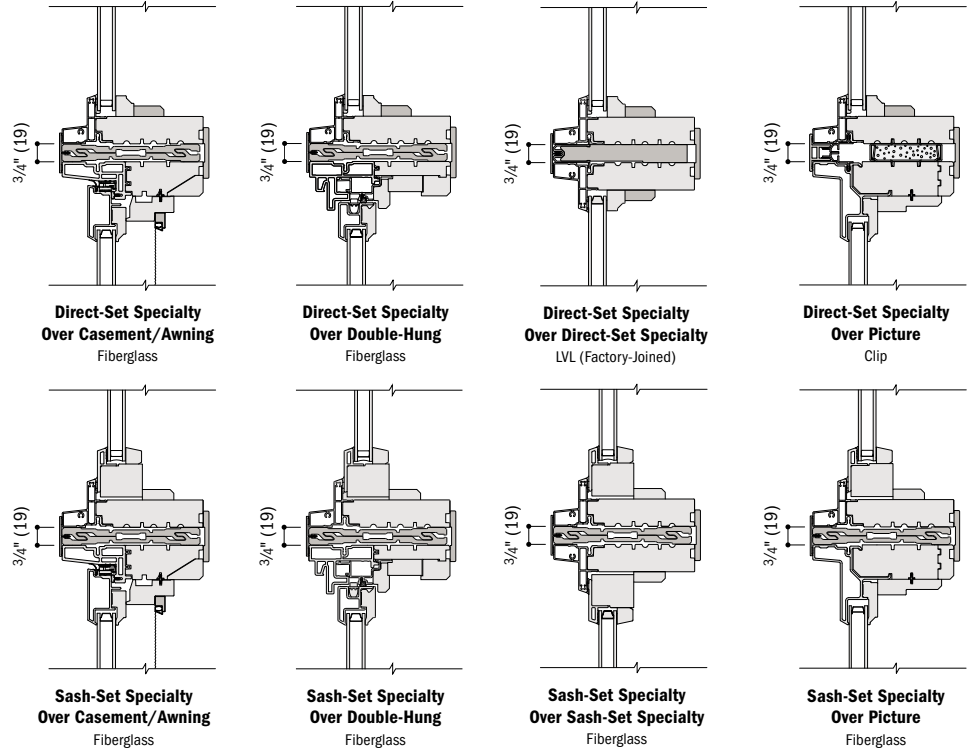

* Light-colored areas are parts included with window. Dark-colored areas are additional Andersen® parts required to complete window assembly as shown.
 * Dimensions in parentheses are in millimeters.
 * Minimum rough openings may need to be increased to allow for use of building wraps, flashing, sill panning, brackets, fasteners or other items. See installation information on pages 226-227.
 * Details are for illustration only and are not intended to represent product installation methods or materials. Refer to product installation instructions at andersenwindows.com.
 * Structural performance of any combination is only as high as the lowest structural performance of any individual product or join in the combination.



COMPLEMENTARY CASEMENT WINDOWS

Custom Sizes	116
Window Details	117-118
Product Performance	206

CUSTOM SIZING
in 1/8" (3) increments 

Dimensions in parentheses are in millimeters.

COMPLEMENTARY CASEMENT WINDOWS

FEATURES

FRAME

A Heavy-duty extruded aluminum cladding protects the frame exterior, providing low-maintenance durability. Standard cladding finish meets AAMA 2604. An optional finish that meets the AAMA 2605 standard is also available.

B Wood frame members are treated with a water-repellent preservative for long-lasting protection and performance.

Installation flange extends 1 1/2" (38) around the perimeter of the unit for positioning and locating. Installation clips are standard for increased structural anchoring to building members. Mounted around the frame perimeter, the clips rotate into position and can be bent into place against the framing members to suit all jamb conditions.



C Interior stops are unfinished. Low-maintenance prefinished white, dark bronze and black interiors are also available.

SASH

D Wood core members provide excellent structural stability and energy efficiency.

E Heavy-duty extruded aluminum cladding protects the sash exterior, providing low-maintenance durability.

F Weatherstrip throughout the unit provides a long-lasting, energy-efficient seal. Rain skirt is factory installed on the perimeter of the sash.

GLASS

G In addition to stainless steel glass spacers, black or white glass spacers are available to allow the spacer to blend in with the unit color.

H Silicone glazing bead combined with two-sided silicone tape provide superior weathertightness.

I High-Performance options include:

- Low-E4® glass
- Low-E4 HeatLock® glass
- Low-E4 SmartSun™ glass
- Low-E4 SmartSun HeatLock glass
- Low-E4 Sun glass

Tempered and other glass options are available; contact your Andersen supplier.

A removable translucent film helps shield the glass from damage during delivery and construction, and simplifies finishing at the job site.

Patterned Glass

Patterned glass options are available. See page 15 for more details.

EXTERIORS & INTERIORS

EXTERIOR COLORS

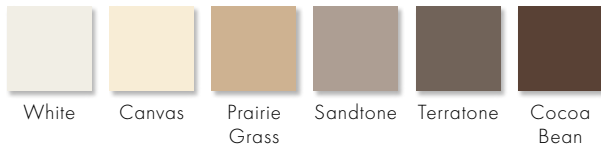

For custom colors, contact your Andersen supplier.

INTERIOR WOOD SPECIES

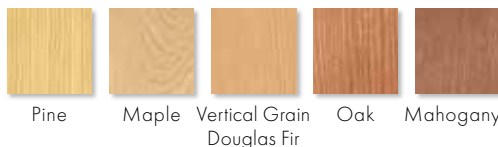

For mixed grain Douglas fir, hickory, white oak and walnut, contact your Andersen supplier. All wood interiors are unfinished unless a paint color is specified. Naturally occurring variations in grain, color and texture of wood make each window one of a kind.

INTERIOR PAINT COLORS

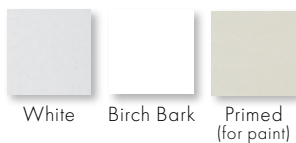

Also available in 11 exterior colors shown above. Painted colors on pine. For custom colors and painted colors on maple, contact your Andersen supplier.

HARDWARE Sold Separately



CONTEMPORARY FOLDING

Black | Bright Brass
Oil Rubbed Bronze | **Satin Nickel**
Stone | White



TRADITIONAL FOLDING

Antique Brass | Black | Bright Brass
Distressed Bronze | Distressed Nickel
Oil Rubbed Bronze | Satin Nickel
Stone | White

Folding handles avoid interference with window treatments.



CLASSIC SERIES™

Stone | **White**



ESTATE™

Antique Brass | Bright Brass
Distressed Bronze | Distressed Nickel
Oil Rubbed Bronze | Satin Nickel

Bold name denotes finish shown.

HARDWARE FINISHES



Distressed bronze and oil rubbed bronze are "living" finishes that will change with time and use.

Printing limitations prevent exact replication of colors and finishes. See your Andersen supplier for actual color and finish samples.

Dimensions in parentheses are in millimeters.

HARDWARE

Smooth Control Hardware System



The smooth control hardware system employs a worm gear drive for easy operation. Units with a wash mode have hinges that move the sash away from the frame to provide easier glass cleaning on rectangular units. Arch and Springline™ casement units use the same smooth control hardware system with stainless steel butt hinges for smooth operation. Hardware option and finish must be specified. Operator handle and cover sold separately.

Single-Actuation Casement Lock



A single-actuation lock easily releases all locking points on the casement sash while the reach-out action eliminates binding when closing. The lock handle is offered in finishes that coordinate with your specified hardware option.

FRENCH CASEMENT



Andersen® complementary French casements allow both sash to swing outward from the center, eliminating a center mullion post. They offer smooth operating multi-point locking mechanisms and hinges. The multi-point lock is activated with a single turn of a handle that simultaneously secures both sash. French casement windows have a unique locking handle that's available in antique brass, black, bright brass, oil rubbed bronze, satin nickel, stone and white finishes.

ACCESSORIES Sold Separately

FRAME

Extension Jamb



Complementary casement jamb depth is 3 3/8" (86). Extension base jambs are available in 1/16" (1.5) increments between 4 7/16" (116) and 7 1/8" (181). Additional dimensions are available. Contact your Andersen supplier for more information. Extension jambs are available in all wood species and interior colors. Available for job site application or can be factory applied.

HARDWARE

Corrosion-Resistant Components



Corrosion-resistant hinge and operator arm hardware is designed for applications in harsh and corrosive environments such as heavy industrial or coastal areas.* Shown above on a 400 Series casement window.

Window Opening Control Device



A window opening control device is available, which limits sash travel to less than 4" (102) when the window is first opened. Available factory applied, or as a field-applied kit in black, stone and white. Not available for French casement windows.

SPECIAL USE OPERATOR HANDLES

Available in Classic Series™ design only.

Compact Operator Handle



Specially designed for use in situations where blinds or other window treatments interfere with standard operator handle. Available in white or stone finish.

Easy-Grip Handle

Larger knob makes it easier to grip and operate. Available in white or stone finish.



Operator Spline Cover



An operator spline cover is an attractive cap that covers the roto operator stud when the handle has been removed to control access or operation of the window. The operator spline cover should not be used on any window designated or intended for emergency escape or rescue. Please consult your local building code official for local egress code requirements.

Metal T-Handle



Our smallest operator handle, the metal T-handle, may make it more difficult for young children (5 and under) to open the window. For more information on child safety, write:

Andersen Corporation
LookOut For Kids® Program
100 Fourth Avenue North
Bayport, MN 55003
Call 800-313-8889 or email
lofk@andersencorp.com.

INSECT SCREENS

TruScene® Insect Screens



Our TruScene insect screens let in over 25% more fresh air** and provide 50% greater clarity than Andersen conventional insect screens, all while keeping out unwanted small insects. For complementary casement windows, TruScene frames are available in white, stone, dark bronze and black as well as pine, maple and oak wood veneers.

Conventional Insect Screens

Conventional insect screens have black fiberglass screen mesh. Optional charcoal powder-coated aluminum screen mesh is available. Frames are available in white, stone, dark bronze and black.

CAUTION:

- Do not paint weatherstrip.
- Creosote-based stains should not come in contact with Andersen products.
- Abrasive cleaners or solutions containing corrosive solvents should not be used on Andersen products.

A-Series
Complementary
Casement Windows

*Visit andersenwindows.com/warranty for details.

**TruScene insect screens let in over 25% more fresh air than standard Andersen fiberglass insect screens.

Dimensions in parentheses are in millimeters.

COMPLEMENTARY CASEMENT WINDOWS

Shapes and Sizes

Choose left, right or stationary as viewed from the exterior. Standard sizes are available for casement windows along with the custom sizing shown below. Picture and transom windows are also available. For standard sizes, minimum rough opening dimensions and opening specifications, contact your Andersen supplier. Complementary casement windows are designed to be standalone feature windows and cannot be directly joined to A-Series windows or doors.



Custom-size windows are available in 1/8" (3) increments between minimum and maximum widths and heights. Some restrictions apply. Standard sizes are also available.

French Casement

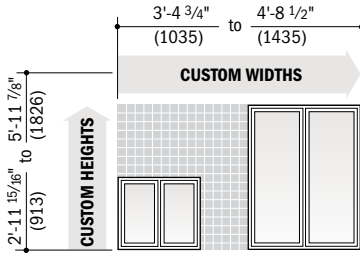

Springline™ French Casement

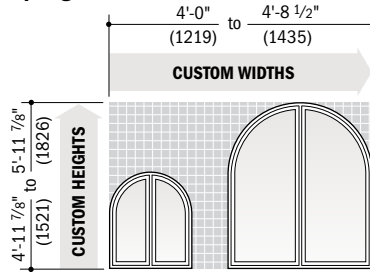

Arch French Casement

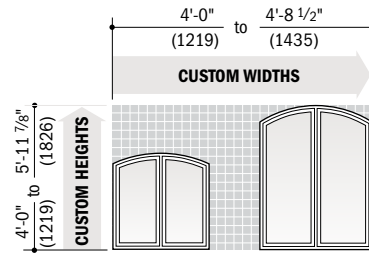

Springline™ Casement*

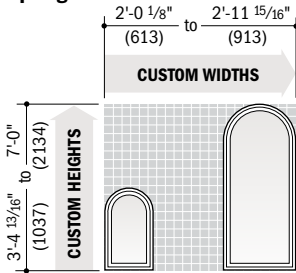

Springline™ Flanker Casement*

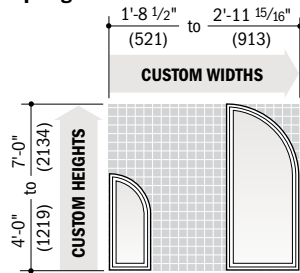

Twin Springline™ Casement*

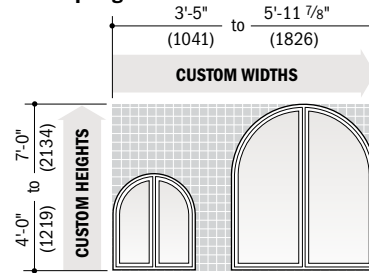

Arch Casement*

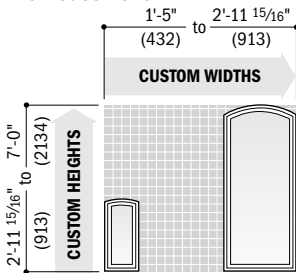

Twin Arch Casement*

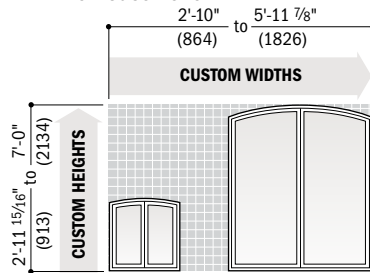

Triple Arch Casement*

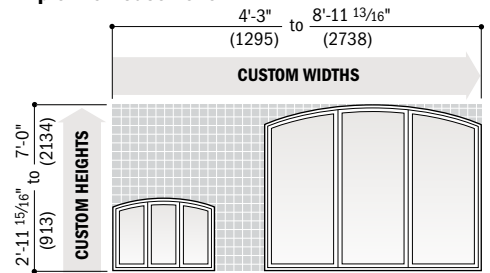

Trapezoid Casement*

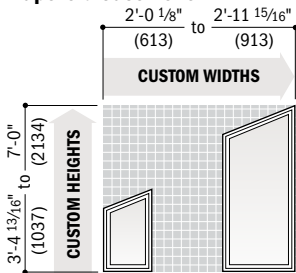

Unequal Leg Arch Casement

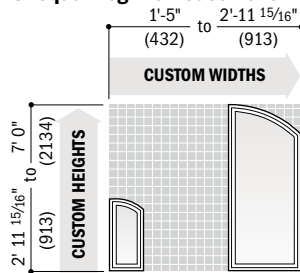

Casement

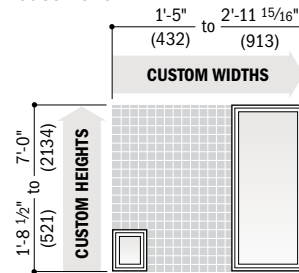

* Rough openings may need to be increased to allow for use of building wraps, flashing, sill panning, brackets, fasteners or other items. See pages 226-227 for more details.

• Dimensions in parentheses are in millimeters.

*For exterior wall cladding that extends beyond the face of the window, there may be a reduction in the amount of opening "swing" when the top of the sash touches the wall cladding.

Clad Complementary French Casement Window Details - Venting

Scale 1 1/2" (38) = 1'-0" (305) – 1:8

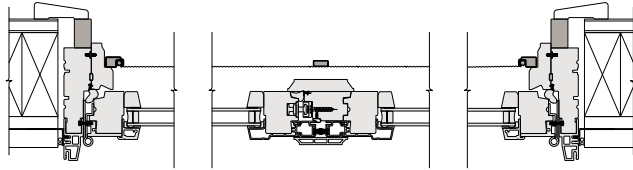

Horizontal Section
French Springline™ Casement

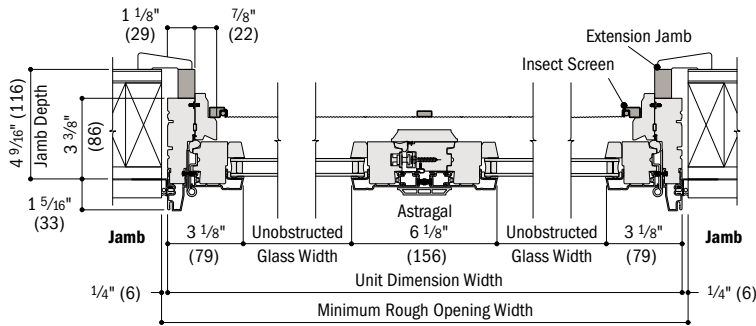

Horizontal Section
French Casement and French Arch Casement

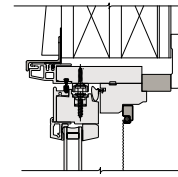

Head - Curved

French Springline™ Casement and French Arch Casement

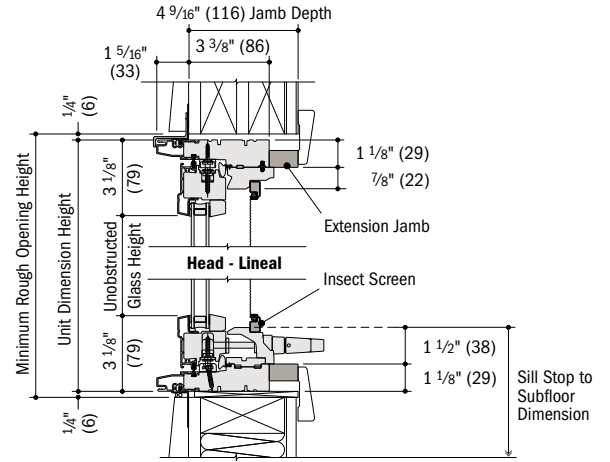

Vertical Section

French Casement and French Arch Casement

Clad Complementary French Casement Window Details - Stationary

Scale 1 1/2" (38) = 1'-0" (305) – 1:8

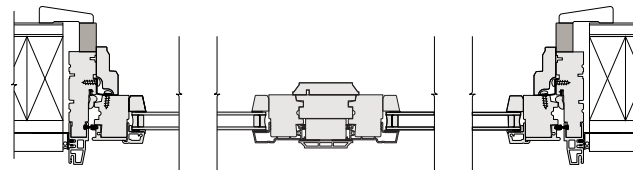

Horizontal Section
French Springline™ Casement

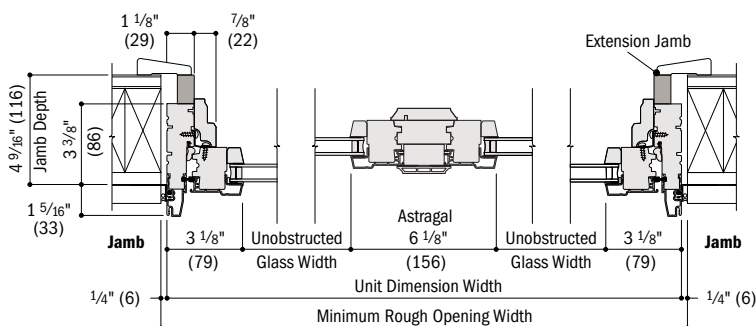

Horizontal Section
French Casement and French Arch Casement

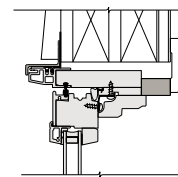

Head - Curved

French Springline™ and French Arch Casement

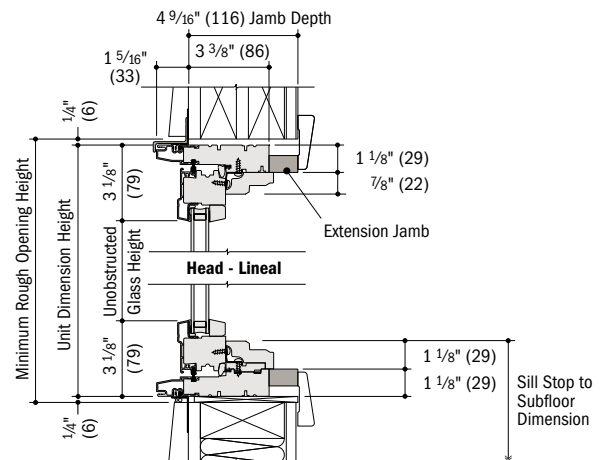

Vertical Section

French Casement and French Arch Casement

- 4 9/16" (116) overall jamb depth and 3 3/8" (86) base jamb depth measurements are from back side of installation flange.
- Light-colored areas are parts included with window. Dark-colored areas are additional Andersen® parts required to complete window assembly as shown.
- Dimensions in parentheses are in millimeters.
- **Minimum rough openings may need to be increased to allow for use of building wraps, flashing, sill panning, brackets, fasteners or other items. See installation information on pages 226-227.**
- Details are for illustration only and are not intended to represent product installation methods or materials. Refer to product installation instructions at andersenwindows.com.

COMPLEMENTARY CASEMENT WINDOWS

Clad Complementary Casement Window Details - Venting

Scale 1 1/2" (38) = 1'-0" (305) - 1:8

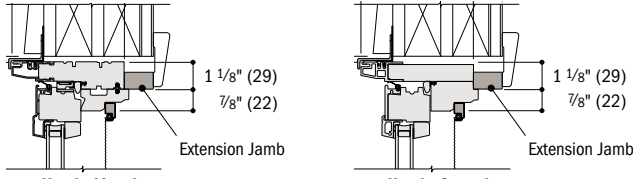

Head - Lineal
Trapezoid Casement

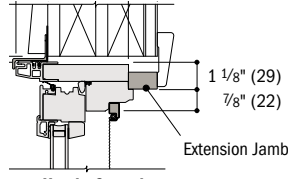

Head - Curved
Arch Casement, Unequal Leg Arch Casement,
Springline™ Casement and Springline Flanker Casement

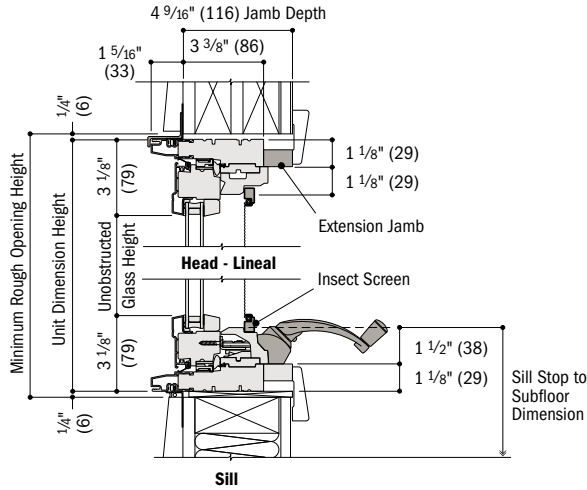

Vertical Section
Casement

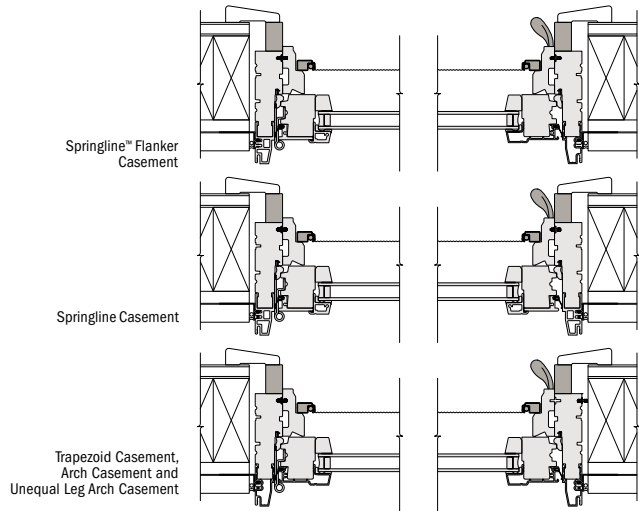

Springline™ Flanker Casement

Springline Casement

Trapezoid Casement,
Arch Casement and
Unequal Leg Arch Casement

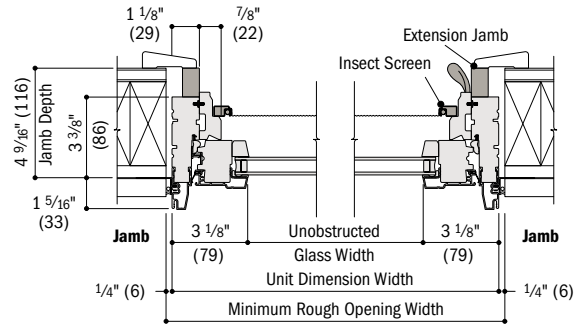

Horizontal Section
Casement

Clad Complementary Casement Window Details - Stationary

Scale 1 1/2" (38) = 1'-0" (305) - 1:8

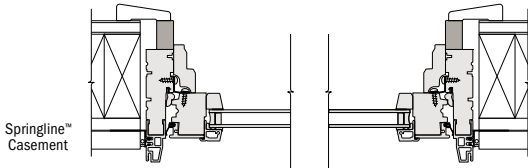

Springline™ Casement

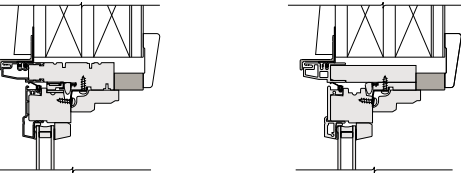

Head - Lineal
Trapezoid Casement

Head - Curved
Arch Casement, Unequal Leg Arch Casement,
Springline™ Casement and Springline Flanker Casements

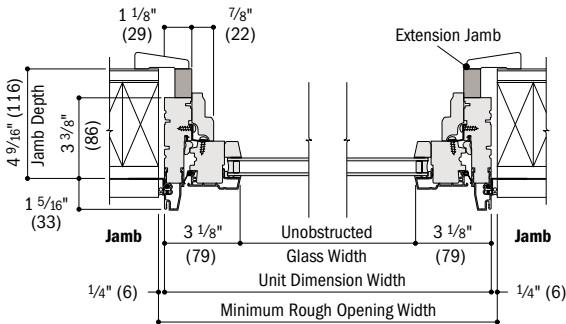

Horizontal Section
Casement, Trapezoid Casement, Arch Casement and Unequal Leg Arch Casement

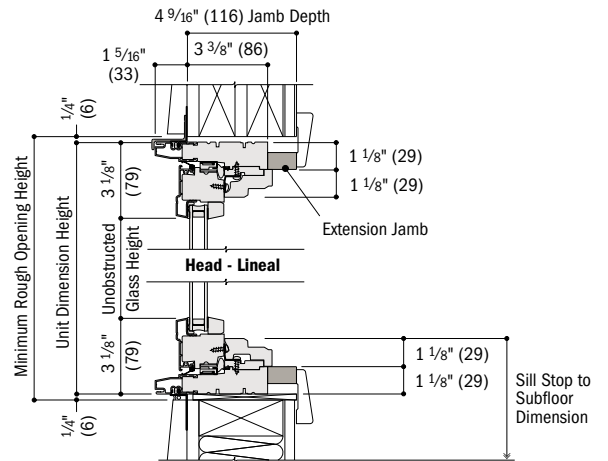

Vertical Section
Casement

- 4 9/16" (116) overall jamb depth and 3 3/8" (86) base jamb depth measurements are from back side of installation flange.
- Light-colored areas are parts included with window. Dark-colored areas are additional Andersen® parts required to complete window assembly as shown.
- Dimensions in parentheses are in millimeters.
- **Minimum rough openings may need to be increased to allow for use of building wraps, flashing, sill panning, brackets, fasteners or other items. See installation information on pages 226-227.**
- Details are for illustration only and are not intended to represent product installation methods or materials. Refer to product installation instructions at andersenwindows.com.

PATIO DOORS

Gliding

Table of Sizes	126-127
Specifications	128
Grille Patterns	129
Door Details	130-133

Hinged Inswing

Table of Sizes	134-137
Specifications	138-139
Grille Patterns	140
Door Details	141-149

Hinged Outswing

Table of Sizes	150-151
Specifications	152
Grille Patterns	151
Door Details	153-155

Sidelights & Transoms

Tables of Sizes	156-161
Specifications	161-163
Grille Patterns	164
Sidelight & Transom Details	164-167

Joining Details	168-171
Custom Sizing	172-175
Combination Designs	196
Product Performance	206

CUSTOM SIZING
in 1/8" (3) increments 
CUSTOM SIZES

Dimensions in parentheses are in millimeters.



PATIO DOORS

FEATURES

GLIDING PATIO DOORS

FRAME

A The frame is constructed with a wood core and a fiberglass exterior. This construction produces a rigid frame and a low-maintenance, durable exterior.

B Wood members are treated with a water-repellent preservative for long-lasting* protection and performance.

The interior wood jamb has an extension jamb kerf, making it easy to add interior extension jambs to match the wall depth.

C The weather seal is made from a flexible polyethylene leaf with a urethane foam core on the sill and stationary side jambs, and a polypropylene fin weatherstrip on the head and operating side jambs, creating a positive seal between the frame and panels. This system provides a long-lasting, energy-efficient barrier against wind, water and dust.

SILL

D The one-piece fiberglass design provides superior water management. The nonconductive fiberglass construction enhances energy performance, and its superior strength eliminates the need for a sill support.

The slip- and wear-resistant poly bead finish is available in either a neutral gray or dark bronze color.

The roller track has a stainless steel cap that resists denting for smooth, reliable operation.

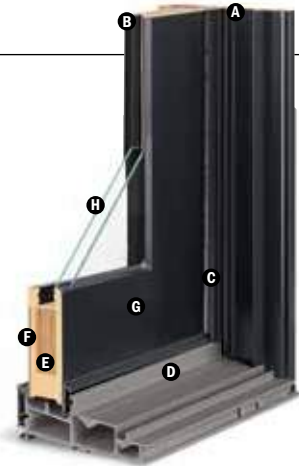

Contemporary Panel

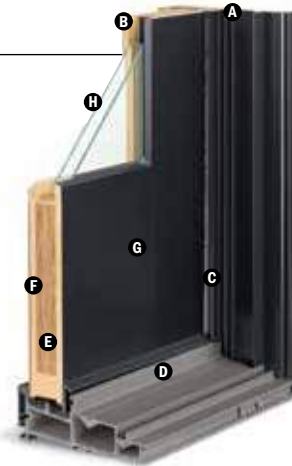

Traditional Panel

PANEL

E Panel stiles and rails are constructed of an engineered Laminated Veneer Lumber (LVL) core. This LVL core provides strength and helps prevent warping for consistent, smooth operation.

Now available with contemporary panels in addition to traditional panels. Contemporary panels feature 5 5/8" (143) stiles and top rail with a 6 1/4" (159) bottom rail and contemporary glass stops. Traditional panels feature 5 5/8" (143) stiles and top rail with a 10 1/2" (267) bottom rail and traditional glass stops.

F Interior panel surfaces are constructed from premium wood veneer available in pine, maple, vertical grain Douglas fir, oak, mahogany** and cherry. All prefinished interiors use water-based paints and stains.

G The exterior of the wood panel is protected with a Flexacron® paint system; this stabilized polyester paint is electrostatically applied to penetrate all exterior surfaces for maximum protection and a lustrous, low-maintenance finish.

Dual corrosion-resistant* ball-bearing rollers on the door panels provide smooth gliding operation with self-contained leveling adjusters.

Dual ball-bearing rollers have deep grooves to increase engagement with the roller track and resist lateral movement.

A parting stop bracket adds strength to the door by reinforcing the top of the panels.

Flexible Seal



A full-length combination weatherstrip/interlock system provides a flexible seal at the meeting stile. Shown above on a 400 Series Frenchwood® gliding patio door.

CONFIGURATIONS

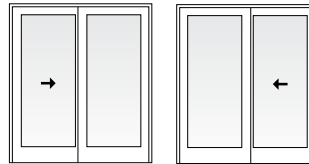

Two-Panel

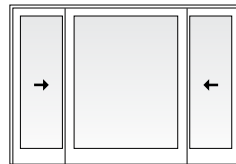

Three-Panel

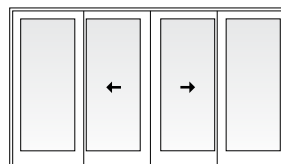

Four-Panel

H GLASS

See Common Features on page 123 for details.

Blinds-Between-the-Glass



Blinds-between-the-glass are available for select door sizes when ordered with Low-E4® tempered glass and any exterior or interior color. White or slate gray 1/2" (13) aluminum slat blinds come mounted between the glass. Available in 3368, 33611, 6068, 60611, 111068-4, 1110611-4, 2968, 5068 and 91068-4 door sizes.

HARDWARE

Multi-Point Locking System for Standard Hardware



The multi-point locking system for standard hardware features a unique reachout design that pulls the door panel tightly closed for a weathertight seal and enhanced security.

Two-Point Locking System for Flush Hardware

The two-point locking system for flush hardware provides intuitive adjustment. Equipped with laminated stainless steel hooks and an anti-slam device to prevent damage to the side jamb.

PERFORMANCE

See Common Features on page 123 for details.

**Actual wood species is either Sapele or Sipo, both non-endangered species grown in Africa, with color and characteristics similar to Central American mahoganies.

*Flexacron® is a registered trademark of PPG Industries, Inc. Andersen patio doors are not intended for use as entrance doors. Dimensions in parentheses are in millimeters.

FEATURES

HINGED INSWING PATIO DOORS

FRAME

A The frame is constructed with a wood core and a fiberglass exterior. This construction produces a rigid frame and a low-maintenance, durable exterior.

B Wood members are treated with a water-repellent preservative for long-lasting* protection and performance.

The interior wood jamb has an extension jamb kerf, making it easy to add interior extension jambs to match the wall depth.

Hinged inswing patio doors are available in 4 9/16" (116) and 6 1/16" (167) base jamb depths.

SILL

C This one-piece fiberglass design provides superior water management. The nonconductive fiberglass construction enhances energy performance, and its superior strength eliminates the need for a sill support.

The slip- and wear-resistant poly bead finish is available in either a neutral gray or dark bronze color.

PANEL

D Panel stiles and rails are constructed of an engineered Laminated Veneer Lumber (LVL) core. This LVL core provides strength and helps prevent warping for consistent, smooth operation.

Now available with contemporary panels in addition to traditional panels. Contemporary panels feature 5 5/8" (143) stiles and top rail with a 6 1/4" (159) bottom rail and contemporary glass stops. Traditional panels feature 5 5/8" (143) stiles and top rail with a 10 1/2" (267) bottom rail and traditional glass stops.

E Interior panel surfaces are constructed from premium wood veneer available in pine, maple, vertical grain Douglas fir, oak, mahogany** and cherry. All prefinished interiors use water-based paints and stains.

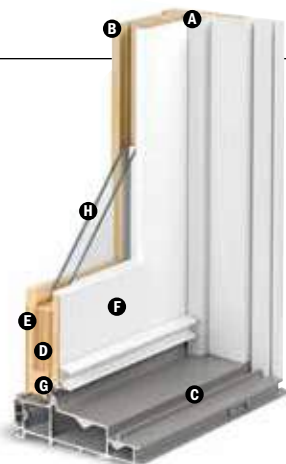

Contemporary Panel

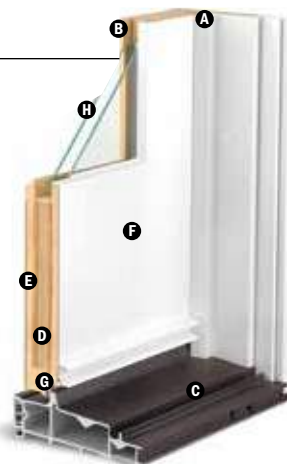

Traditional Panel

F The exterior of the wood panel is protected with a Flexacron® paint system; this stabilized polyester paint is electrostatically applied to penetrate all exterior surfaces for maximum protection and a lustrous, low-maintenance finish.

G Factory-applied, one-piece (welded corners), compression-type weatherstrip made from a durable thermoplastic material is attached directly to the panel, not the frame, creating a continuous seal around the panel to provide maximum effectiveness against air and water infiltration. This system provides a long-lasting, energy-efficient barrier against wind, water and dust.

Two-panel doors are available with one or two active panels. For doors with one active panel, hinges can be located along either the jamb or astragal.

Adjustable Hinges

Adjustable hinges have ball-bearing pivots for smooth, frictionless movement and feature easy horizontal and vertical adjustments, plus release tabs for easy panel removal. Available in finishes that coordinate with most trim set hardware finishes.



Removable Panels

Panels can be easily removed with the unique panel-release tab on the hinge. Release tabs are covered with a cap for a clean appearance. This release feature is ideal for transporting large units up stairs or to other hard-to-reach areas.

H GLASS

See Common Features on page 123 for details.

Blinds-Between-the-Glass



Blinds-between-the-glass are available for select door sizes when ordered with Low-E4® tempered glass and any exterior or interior color. White or slate gray 1/2" (13) aluminum slat blinds come mounted between the glass. Available in 2768, 27611, 5068, 50611, 2968, 5468, 71168, 3168, 31611, 6068, 60611, 81168 and 811611 door sizes.

HARDWARE

Multi-Point Locking System



Hinged doors have a multi-point locking system that combines hook bolts with a center deadbolt. This system provides added weathertightness and enhanced security.

Optional Corrosion-Resistant Hardware

An optional corrosion-resistant locking mechanism is available and recommended for applications within two miles of the coast and other harsh environments.

PERFORMANCE

See Common Features on page 123 for details.

*Visit andersenwindows.com/warranty for details.

**Actual wood species is either Sapele or Sipo, both non-endangered species grown in Africa, with color and characteristics similar to Central American mahoganies.

"Flexacron" is a registered trademark of PPG Industries, Inc.

Andersen patio doors are not intended for use as entrance doors.

Dimensions in parentheses are in millimeters.

PATIO DOORS

FEATURES

HINGED OUTSWING PATIO DOORS

FRAME

A The frame is constructed with a wood core and a fiberglass exterior. This construction produces a rigid frame and a low-maintenance, durable exterior.

B Wood members are treated with a water-repellent preservative for long-lasting* protection and performance.

The interior wood jamb has an extension jamb kerf, making it easy to add interior extension jambs to match the wall depth.

SILL

C One-piece non-conductive fiberglass construction enhances energy performance, and its superior strength eliminates the need for a sill support. An innovative sill design provides superior water management.

The slip- and wear-resistant poly bead finish is available in either a neutral gray or dark bronze color.

PANEL

D Panel stiles and rails are constructed of an engineered Laminated Veneer Lumber (LVL) core. This LVL core provides strength and helps prevent warping for consistent, smooth operation.

Now available with contemporary panels in addition to traditional panels. Contemporary panels feature 5 5/8" (143) stiles and top rail with a 6 1/4" (159) bottom rail and contemporary glass stops. Traditional panels feature 5 5/8" (143) stiles and top rail with a 10 1/2" (267) bottom rail and traditional glass stops.

E Interior panel surfaces are constructed from premium wood veneer available in pine, maple, vertical grain Douglas fir, oak, mahogany** and cherry. All prefinished interiors use water-based paints and stains.

F The exterior of the wood panel is protected with a Flexacron® paint system; this stabilized polyester paint is electrostatically applied to penetrate all exterior surfaces for maximum protection and a lustrous, low-maintenance finish.

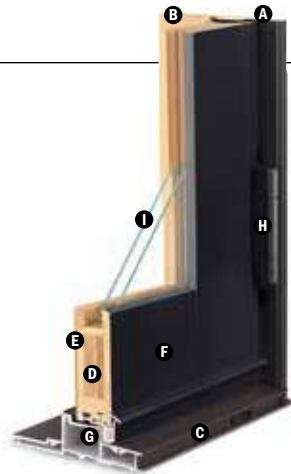

Contemporary Panel

G Factory-applied, one-piece (welded corners), compression-type weatherstrip made from a durable thermoplastic material is attached directly to the panel, not the frame, creating a continuous seal around the panel to provide maximum effectiveness against air and water infiltration. This system creates a strong, long-lasting* seal that stands up to harsh weather.

Hinged outswing operating panels are available in either single left- or right-hand active or two-panel active-passive or passive-active jamb hinged.

Adjustable Hinges

H The ball-bearing hinges are covered with a corrosion-resistant powder-coated finish. Adjustable hinges have ball-bearing pivots for smooth, frictionless movement and feature easy horizontal and vertical adjustments, plus release tabs for easy panel removal. Hinges are color-matched to the exterior.

Removable Panels



Panels can be easily removed with the unique panel-release tab on the hinge. Release tabs are covered with a cap for a clean appearance. This release feature is ideal for transporting large units up stairs or to other hard-to-reach areas.

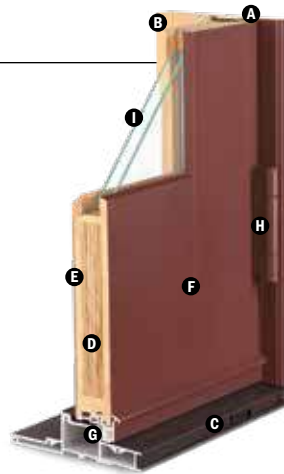

Traditional Panel

I GLASS

See Common Features on page 123 for details.

Blinds-Between-the-Glass



Blinds-between-the-glass are available for select door sizes when ordered with Low-E4® tempered glass and any exterior or interior color. White or slate gray 1/2" (13) aluminum slat blinds come mounted between the glass. Available in 2768, 27611, 5068, 50611, 2968, 5468, 3168, 31611, 6068 and 60611 door sizes.

HARDWARE

Multi-Point Locking System



Hinged doors have a multi-point locking system that combines hook bolts with a center deadbolt. This system provides added weather-tightness and enhanced security.

Optional Corrosion-Resistant Hardware

An optional corrosion-resistant locking mechanism and hinges are available and recommended for applications within two miles of the coast and other harsh environments.

PERFORMANCE

See Common Features on page 123 for details.

*Visit andersenwindows.com/warranty for details.

**Actual wood species is either Sapele or Sipo, both non-endangered species grown in Africa, with color and characteristics similar to Central American mahoganies.

Flexacron® is a registered trademark of PPG Industries, Inc. Andersen patio doors are not intended for use as entrance doors.

Dimensions in parentheses are in millimeters.

FEATURES

PATIO DOOR SIDELIGHTS

FRAME

The frame is constructed with a wood core and a fiberglass exterior. This construction produces a rigid frame and a low-maintenance, durable exterior.

Wood members are treated with a water-repellent preservative for long-lasting* protection and performance.

The interior wood jamb has an extension jamb kerf, making it easy to add interior extension jambs to match the wall depth.

SILL

The one-piece fiberglass design provides superior water management. The nonconductive fiberglass construction enhances energy performance, and its superior strength eliminates the need for a sill support.

The slip- and wear-resistant poly bead finish is available in either a neutral gray or dark bronze color.

PANEL

Panel stiles and rails are constructed of an engineered Laminated Veneer Lumber (LVL) core. This LVL core provides strength and helps prevent warping.

Now available with contemporary panels in addition to traditional panels. Contemporary panels feature 5 5/8" (143) stiles and top rail with a 6 1/4" (159) bottom rail and contemporary glass stops. Traditional panels feature 5 5/8" (143) stiles and top rail with a 10 1/2" (267) bottom rail and traditional glass stops.

Interior panel surfaces are constructed from premium wood veneer available in pine, maple, vertical grain Douglas fir, oak, mahogany** and cherry. All prefinished interior options use water-based paints and stains.

The exterior of the wood panel is protected with a Flexacron® paint system; this stabilized polyester paint is electrostatically applied to penetrate all exterior surfaces for maximum protection and a lustrous, low-maintenance finish.

GLASS

See Common Features below.

PERFORMANCE OPTIONS

See Common Features below.



Sidelights and sash-set transoms shown with traditional option; contemporary option also available.

PATIO DOOR TRANSOMS

FRAME

The frame is constructed with a wood core and a fiberglass exterior. This construction produces a rigid frame and a low-maintenance, durable exterior.

Wood members are treated with a water-repellent preservative for long-lasting* protection and performance.

The interior wood jamb has an extension jamb kerf, making it easy to add interior extension jambs to match the wall depth.

SASH

Direct-set transoms have glass glazed directly into the frame and maximize the glass area.

Sash-set transoms feature a fixed sash and provide common sight lines with A-Series patio doors. Available with contemporary or traditional glass stops to match your door panel option. Available in pine, maple, vertical grain Douglas fir, oak, mahogany** and cherry. All prefinished interior options use water-based paints and stains.

GLASS

See Common Features below.

PERFORMANCE

See Common Features below.

VENTING TRANSOMS

Venting transom windows are also available in sizes to fit over doors. See pages 52-53.

A-Series Patio Door Overview

COMMON FEATURES

GLASS

In addition to stainless steel glass spacers, black or white glass spacers are available to allow the spacer to blend in with the unit color.

3/4" (19) dual-pane glass construction provides exceptional energy performance. High-Performance dual-pane glass options include:

- Low-E4® tempered glass
- Low-E4 HeatLock® tempered glass
- Low-E4 SmartSun™ tempered glass
- Low-E4 SmartSun HeatLock tempered glass
- Low-E4 Sun tempered glass

For even greater energy performance, 1" (25) triple-pane glass is available in these options:

- Low-E4 tempered glass
- Low-E4 Enhanced tempered glass
- Low-E4 Enhanced HeatLock tempered glass
- Low-E4 SmartSun tempered glass

- Low-E4 SmartSun Enhanced tempered glass
- Low-E4 SmartSun Enhanced HeatLock tempered glass

Additional glass options are available; see your Andersen supplier.

A removable translucent film helps shield the glass from damage during delivery and construction, and simplifies finishing at the job site.

Patterned Glass

Patterned glass options are available. See page 15 for more details.

Between-the-Glass Art Glass

Available in a variety of original patterns. For details see page 16 or visit andersenwindows.com/artglass.

PERFORMANCE

Performance Grade (PG) Upgrade Drop-Nose Channel

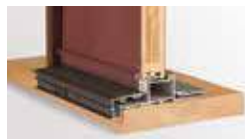

A factory-applied, patented drop-nose channel attachment is available for doors to enhance water performance without increasing the interior sill height. PG upgrades allow standard non-impact products to achieve higher performance ratings. Performance Grade (PG) ratings are more comprehensive than Design Pressure (DP) ratings for measuring product performance. For up-to-date performance information of individual products, visit andersenwindows.com. Shown on a hinged inswing door.



A-Series patio doors available with Stormwatch® Protection include impact-resistant glass in addition to structural upgrades. For a copy of the A-Series Coastal Product Guide, visit andersenwindows.com/coastal.

**Actual wood species is either Sapele or Sipo, both non-endangered species grown in Africa, with color and characteristics similar to Central American mahoganies.

*Flexacron® is a registered trademark of PPG Industries, Inc. Dimensions in parentheses are in millimeters.

PATIO DOORS

EXTERIORS & INTERIORS

EXTERIOR COLORS



INTERIOR WOOD SPECIES



FACTORY-FINISHED INTERIORS

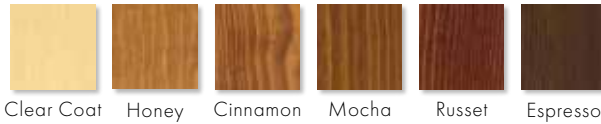

All wood interiors are unfinished unless a finish is specified. Factory finishes on pine, maple and oak. Shown above on pine. Naturally occurring variations in grain, color and texture of wood make each window one of a kind.

INTERIOR PAINT COLORS



Also available in 11 exterior colors shown at left; contact your Andersen supplier. Painted colors on pine or maple.

HARDWARE Sold Separately



HARDWARE FINISHES

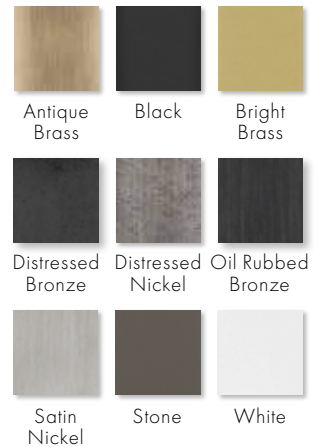

Bold name denotes finish shown.

FSB® HARDWARE FOR HINGED PATIO DOORS

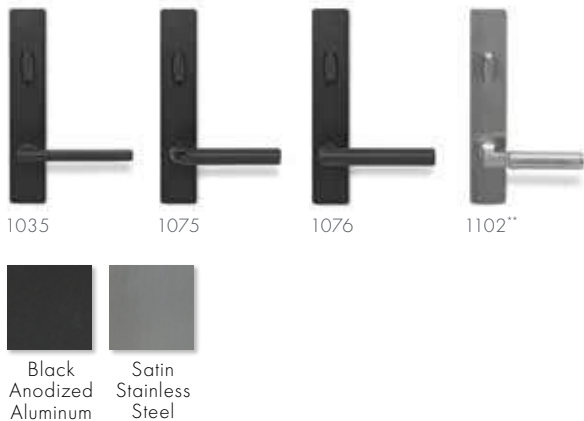

FLUSH HARDWARE FOR GLIDING PATIO DOORS



*Actual wood species is either Sapele or Sipo, both non-endangered species grown in Africa, with color and characteristics similar to Central American mahoganies.

**FSB style 1102 is not available in black anodized aluminum.

Matching hinges available in most hardware finishes for inswing patio doors; excludes FSB hardware.

Mix-and-match interior and exterior style and finish options are available; excludes FSB and flush hardware.

Bright brass and satin nickel finishes feature a 10-year limited warranty.

Albany and Tribeca hardware are zinc die-cast with powder-coated durable finish; Yuma, Encino, Newbury and Anvers are solid forged brass..

Distressed bronze and oil rubbed bronze are "living" finishes that will change with time and use.

Printing limitations prevent exact replication of colors and finishes. See your Andersen supplier for actual color and finish samples.

"FSB" is a registered trademark of Franz Schneider Brakel GmbH & Co.

ACCESSORIES Sold Separately

FRAME

Extension Jamb

Extension jambs are available in pine, maple, vertical grain Douglas fir, oak, mahogany* and cherry precut to fit the unit. Available in 1/8" (1.5) increments up to 7 1/8" (181) and can be prefinished in six stain colors as well as all interior paint options to match the interior finish of the unit. This option is also available factory applied.

Interior extension jambs on inswing units will restrict the full opening of the door.

Threshold for Gliding and Hinged Inswing Patio Doors



A maple or oak threshold is available for finishing the interior of the sill on gliding and hinged inswing doors.

Sill Step for Hinged Outswing Patio Doors

The hinged outswing door offers an optional maple or oak sill step. Detail is shown on page 129.

Remodeler Sill Bracket for Gliding and Hinged Inswing Patio Doors



The remodeler sill bracket allows for easy installation in replacement applications with a finished interior floor. It fastens to the subfloor, and the sill snaps into the bracket, providing a secure structural installation. Detail is shown on page 129 for gliding, 141 for inswing and 153 for outswing doors.

HARDWARE

Exterior Keyed Lock



A six-pin exterior key cylinder lock is available for all doors in styles and finishes that coordinate with the hardware. This lock allows the door to be locked and unlocked from the exterior. Gliding door lock shown.

Auxiliary Foot Lock for Gliding Patio Doors



Provides an extra measure of security when the door is in a locked position. Lock can be set so the door is fully closed or partially open to provide a secure venting position. Available in all hardware finishes.

Handle Extension for Hinged Inswing and Outswing Patio Doors



Extends interior door handle an additional 1" (25) from the door panel to accommodate interior blinds or shades. The kit includes one handle extender and spindle. A second extender may be added to the spindle to increase the length an additional 1" (25) to a 2" (51) total extension. Extenders are available in finishes that coordinate with the hardware.

Strike Plate Extension for Hinged Inswing Patio Doors

Antique brass, bright brass, oil rubbed bronze and satin nickel strike plate extensions are available for: 5 1/4" (133), 6 3/8" (167) and 7 1/8" (181) wall depths.

Construction Hardware for Hinged Inswing and Outswing Patio Doors



This hardware can be used to help secure the job site during the construction phase of the project. It features an undersized escutcheon plate, which makes on-site finishing easier.

Yale® Assure Lock® Keyless Lock for Hinged Patio Doors



Monitor, lock and unlock from anywhere with the Yale Assure Lock. The sleek key-free lock includes Bluetooth® technology for key-free unlocking and is compatible with Z-Wave® for integration with a wide range of smart home platforms. See page 13 for additional details.

INSECT SCREENS

All insect screens have a long-lasting** fiberglass mesh with a charcoal finish. Insect screen frames are color matched to the exterior of the door unless otherwise noted.

Top-Hung Gliding and Gliding Insect Screens for Gliding or Hinged Inswing Patio Doors

Patented square-corner joints add considerable strength to the frame members. Available in premium top-hung and conventional gliding designs. The premium top-hung insect screen has silicone-embedded glide hooks that hang from the top of the screen track, allowing it to glide smoothly and effortlessly without the interference of dust and debris. Alignment rollers on the bottom keep it in place on the track, while the perimeter bug seal helps ensure insects stay out. The conventional insect screen has bottom rollers with self-contained leveling adjusters.

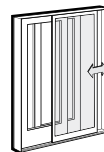

Hinged Insect Screen for Hinged Inswing Patio Doors

Available for single-panel doors.



Double-Hinged Insect Screen for Hinged Inswing Patio Doors

Available for two-panel jamb-hinged doors.



Retractable Insect Screen for Gliding Patio Doors

The retractable insect screen is installed on the exterior of the door and opens side to side across the width of the opening. When the insect screen is not in use, it neatly retracts into a small canister mounted on the exterior of the door. Available for two-panel doors. Please note, the retractable screen track reduces the clear opening height by 1" (25).



Retractable Insect Screen for Hinged Outswing Patio Doors

The retractable insect screen is installed on the interior of the door across the width of the opening. When the insect screen is not in use, it neatly retracts into a small canister mounted on each side of the door. Retractable insect screens are available for single-panel and two-panel doors, and in white, gold dust, pine, maple and oak finishes and six stain options to match the interior of the door. Please note, the retractable screen track reduces the clear opening height by 1" (25).

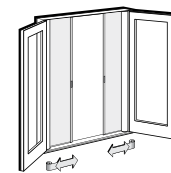

GRILLES

Grilles are available in both traditional and contemporary profiles in a variety of configurations and widths. See page 19 for details.

EXTERIOR TRIM

Available with Andersen exterior trim. See the exterior trim section starting on page 189.

*Actual wood species is either Sapele or Sipo, both non-endangered species grown in Africa, with color and characteristics similar to Central American mahoganies.

**Visit andersenwindows.com/warranty for details.

All marks are trademarks of their respective owners. Dimensions in parentheses are in millimeters.

GLIDING PATIO DOORS

Table of Gliding Patio Door Sizes

Scale 1/8" (3) = 1'-0" (305) – 1:96

Door Dimension	2'-8 3/8" (822)	4'-11 1/4" (1505)	4'-11 1/4" (1505)	9'-9" (2972)	9'-9" (2972)
Minimum Rough Opening	2'-9" (838)	5'-0" (1524)	5'-0" (1524)	9'-10" (2997)	9'-10" (2997)
Unobstructed Glass (single panel only)	21 1/8" (537)	21 1/8" (537)	21 1/8" (537)	21 1/8" (537) 52" (1321) 21 1/8" (537)	21 1/8" (537)

1 FWGD/FWCGD	2968S	5068L	5068R	91068-3	91068-4*
2 FWGD/FWCGD	29611S	50611L	50611R	910611-3	910611-4*
3 FWGD/FWCGD	2980S	5080L	5080R	91080-3	91080-4*
4 FWGD/FWCGD	29100S	50100L	50100R	910100-3	910100-4*



Custom-size patio doors are available in 1/8" (3) increments.

See pages 172 and 175 for custom sizes, specifications and information on shipping patio doors greater than 8' (2438).

Door Dimension	3'-2 3/8" (974)	5'-11 1/4" (1810)	5'-11 1/4" (1810)	11'-9" (3581)	11'-9" (3581)
Minimum Rough Opening	3'-3" (991)	6'-0" (1829)	6'-0" (1829)	11'-10" (3606)	11'-10" (3600)
Unobstructed Glass (single panel only)	27 1/8" (689)	27 1/8" (689)	27 1/8" (689)	27 1/8" (689) 64" (1626) 27 1/8" (689)	27 1/8" (689)

1 FWGD/FWCGD	3368S	6068L	6068R	111068-3	111068-4*
2 FWGD/FWCGD	33611S	60611L	60611R	1110611-3	1110611-4*
3 FWGD/FWCGD	3380S	6080L	6080R	111080-3	111080-4*
4 FWGD/FWCGD	33100S	60100L	60100R	1110100-3	1110100-4*

Door Dimension	3'-8 3/8" (1126)	6'-11 1/4" (2114)	6'-11 1/4" (2114)
Minimum Rough Opening	3'-9" (1067)	7'-0" (2133)	7'-0" (2133)
Unobstructed Glass (single panel only)	33 1/8" (841)	33 1/8" (841)	33 1/8" (841)

1 FWGD/FWCGD	3968S	7068L	7068R
2 FWGD/FWCGD	39611S	70611L	70611R
3 FWGD/FWCGD	3980S	7080L	7080R
4 FWGD/FWCGD	39100S	70100L	70100R

Viewed from the exterior. Arrows indicate direction of panel operation. Choose traditional (FWGD) or contemporary (FWCGD) panels. Contemporary panels shown. Stationary (S) patio doors can be used as an individual door or as a sidelight. Single-panel doors are factory assembled. Two-panel doors are available unassembled, or can be factory assembled and will arrive at the job site ready to install. Three- and four-panel doors are not available factory assembled.

Grille patterns shown on page 129. Details shown on pages 130-133.

Door Dimension	4'-2 3/8" (1279)	7'-11 1/4" (2419)	7'-11 1/4" (2419)	15'-9" (4801)
Minimum Rough Opening	4'-3" (1295)	8'-0" (2438)	8'-0" (2438)	15'-10" (4826)
Unobstructed Glass (single panel only)	39 1/8" (994)	39 1/8" (994)	39 1/8" (994)	39 1/8" (994)

1 FWGD/FWCGD	4368S	8068L	8068R	151068-4*
2 FWGD/FWCGD	43611S	80611L	80611R	1510611-4*
3 FWGD/FWCGD	4380S	8080L	8080R	151080-4*
4 FWGD/FWCGD	43100S	80100L	80100R	1510100-4*

* "Door Dimension" always refers to outside frame-to-frame dimension.
 * "Minimum Rough Opening" dimensions may need to be increased to allow for use of building wraps, flashing, sill panning, brackets, fasteners or other items. See pages 226-227 for more details.
 * Dimensions in parentheses are in millimeters.
 * Add 1/4" (6) to the "Minimum Rough Opening" height dimension for four-panel doors.

Four Patio Door Heights

For all four-panel gliding patio doors, add 1/4" (6) to the "Minimum Rough Opening" height dimension.

Traditional Panels

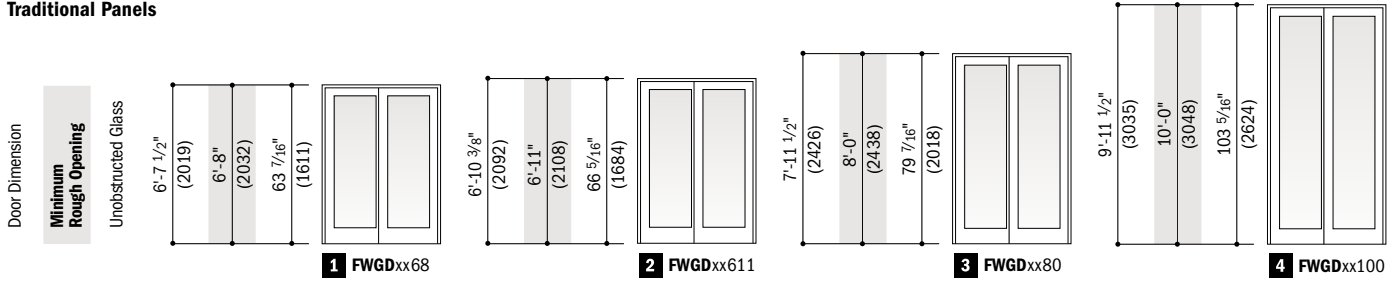

Contemporary Panels

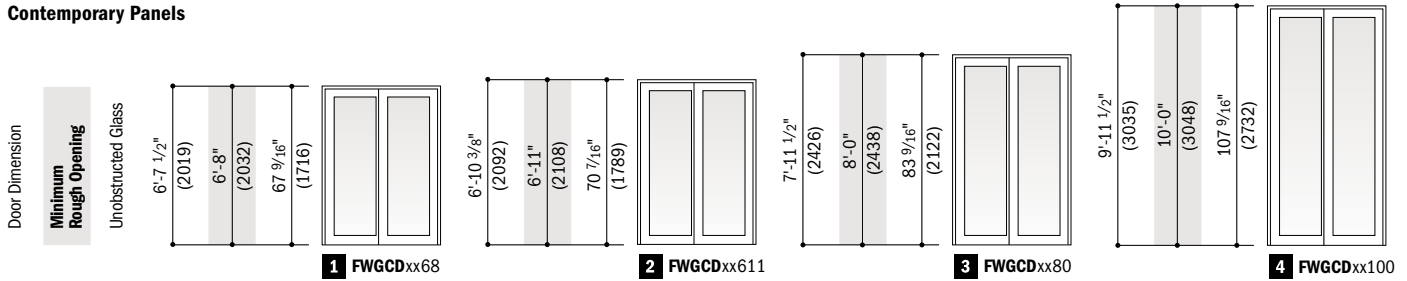

Order Designation Description

Viewed from the exterior. Traditional panels shown.

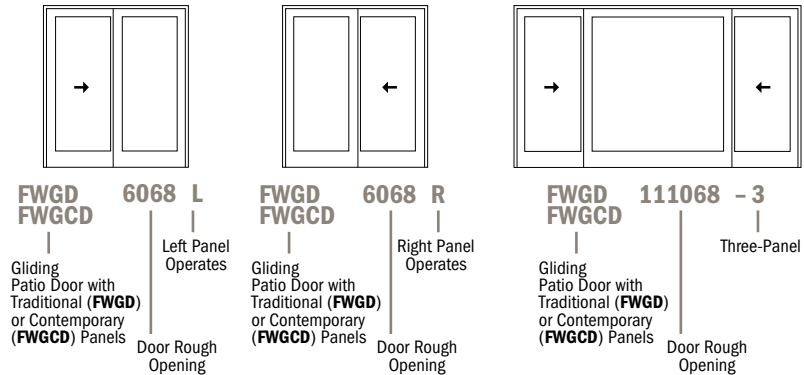

• "Door Dimension" always refers to outside frame-to-frame dimension.
 • "Minimum Rough Opening" dimensions may need to be increased to allow for use of building wraps, flashing, sill panning, brackets, fasteners or other items. See pages 226-227 for more details.
 • Dimensions in parentheses are in millimeters.

GLIDING PATIO DOORS

Gliding Patio Door Opening and Area Specifications

Door Number	Number of Panels in Open Position	Clear Opening Area Sq. Ft./ (m ²)		Clear Opening in Full Open Position		Traditional Panel Glass Area Sq. Ft./ (m ²)		Contemporary Panel Glass Area Sq. Ft./ (m ²)		Vent Area Sq. Ft./ (m ²)		Overall Door Area Sq. Ft./ (m ²)			
				Width Inches/(mm)	Height Inches/(mm)	Sq. Ft./ (m ²)	Sq. Ft./ (m ²)	Sq. Ft./ (m ²)	Sq. Ft./ (m ²)	Sq. Ft./ (m ²)	Sq. Ft./ (m ²)				
FWGD/FWGED2968S	1	-	-	-	-	9.31	(0.86)	9.91	(0.92)	-	-	17.86	(1.66)		
FWGD/FWGED3368S	1	-	-	-	-	11.95	(1.11)	12.73	(1.18)	-	-	21.17	(1.97)		
FWGD/FWGED3968S	1	-	-	-	-	14.59	(1.35)	15.54	(1.44)	-	-	24.48	(2.27)		
FWGD/FWGED4368S	1	-	-	-	-	17.24	(1.60)	18.36	(1.70)	-	-	27.79	(2.58)		
FWGD/FWGED29611S	1	-	-	-	-	9.73	(0.90)	10.33	(0.96)	-	-	18.50	(1.72)		
FWGD/FWGED33611S	1	-	-	-	-	12.49	(1.16)	13.27	(1.23)	-	-	21.93	(2.04)		
FWGD/FWGED39611S	1	-	-	-	-	15.25	(1.41)	16.20	(1.50)	-	-	25.37	(2.36)		
FWGD/FWGED43611S	1	-	-	-	-	18.02	(1.67)	19.14	(1.77)	-	-	28.80	(2.68)		
FWGD/FWGED2980S	1	-	-	-	-	11.65	(1.08)	12.26	(1.13)	-	-	21.45	(1.99)		
FWGD/FWGED3380S	1	-	-	-	-	14.96	(1.38)	15.74	(1.46)	-	-	21.94	(2.04)		
FWGD/FWGED3980S	1	-	-	-	-	18.27	(1.69)	19.22	(1.78)	-	-	29.41	(2.73)		
FWGD/FWGED4380S	1	-	-	-	-	21.58	(2.00)	22.71	(2.10)	-	-	33.39	(3.10)		
FWGD/FWGED29100S	1	-	-	-	-	15.17	(1.40)	15.78	(1.46)	-	-	26.84	(2.49)		
FWGD/FWGED33100S	1	-	-	-	-	19.48	(1.80)	20.26	(1.88)	-	-	31.82	(2.96)		
FWGD/FWGED39100S	1	-	-	-	-	23.79	(2.21)	24.74	(2.29)	-	-	36.80	(3.42)		
FWGD/FWGED43100S	1	-	-	-	-	28.10	(2.61)	29.23	(2.71)	-	-	41.78	(3.88)		
FWGD/FWGED5068	1	11.16	(1.04)	21 1/4"	(540)	75 1/2"	(1918)	18.61	(1.72)	19.83	(1.84)	11.16	(1.04)	32.71	(3.04)
FWGD/FWGED6068	1	14.31	(1.33)	27 1/4"	(692)	75 1/2"	(1918)	23.90	(2.22)	25.46	(2.36)	14.31	(1.33)	39.34	(3.65)
FWGD/FWGED7068	1	17.45	(1.62)	33 1/4"	(845)	75 1/2"	(1918)	29.19	(2.71)	31.09	(2.88)	17.45	(1.62)	45.96	(4.27)
FWGD/FWGED8068	1	20.60	(1.91)	39 1/4"	(997)	75 1/2"	(1918)	34.47	(3.20)	36.72	(3.41)	20.60	(1.91)	52.59	(4.89)
FWGD/FWGED91068-4	2	22.60	(2.10)	43 1/16"	(1094)	75 1/2"	(1918)	37.22	(3.45)	39.66	(3.68)	22.60	(2.10)	64.59	(6.00)
FWGD/FWGED91068-3	1	11.16	(1.04)	21 1/4"	(540)	75 1/2"	(1918)	41.51	(3.85)	44.22	(4.10)	11.16	(1.04)	64.59	(6.00)
FWGD/FWGED111068-4	2	28.89	(2.68)	55 1/16"	(1399)	75 1/2"	(1918)	47.80	(4.44)	50.92	(4.73)	28.89	(2.68)	77.84	(7.23)
FWGD/FWGED111068-3	1	14.31	(1.33)	27 1/4"	(692)	75 1/2"	(1918)	52.08	(4.83)	55.49	(5.15)	14.31	(1.33)	77.84	(7.23)
FWGD/FWGED151068-4	2	41.49	(3.86)	79 1/16"	(2008)	75 1/2"	(1918)	68.94	(6.40)	73.45	(6.82)	41.49	(3.85)	104.34	(9.69)
FWGD/FWGED50611	1	11.58	(1.08)	21 1/4"	(540)	78 7/16"	(1992)	19.46	(1.80)	20.67	(1.92)	11.58	(1.08)	33.89	(3.15)
FWGD/FWGED60611	1	14.85	(1.38)	27 1/4"	(692)	78 7/16"	(1992)	24.98	(2.32)	26.54	(2.46)	14.85	(1.38)	40.76	(3.79)
FWGD/FWGED70611	1	18.12	(1.68)	33 1/4"	(845)	78 7/16"	(1992)	30.51	(2.83)	32.41	(3.01)	18.12	(1.68)	47.62	(4.42)
FWGD/FWGED80611	1	21.39	(1.99)	39 1/4"	(997)	78 7/16"	(1992)	36.03	(3.34)	38.29	(3.55)	21.39	(1.99)	54.49	(5.06)
FWGD/FWGED910611-4	2	23.46	(2.18)	43 1/16"	(1094)	78 7/16"	(1992)	38.91	(3.61)	41.34	(3.84)	23.46	(2.18)	66.93	(6.22)
FWGD/FWGED910611-3	1	11.58	(1.08)	21 1/4"	(540)	78 7/16"	(1992)	43.39	(4.03)	46.10	(4.28)	11.58	(1.08)	66.93	(6.22)
FWGD/FWGED1110611-4	2	29.99	(2.79)	55 1/16"	(1399)	78 7/16"	(1992)	49.96	(4.64)	53.09	(4.93)	29.99	(2.79)	80.66	(7.49)
FWGD/FWGED1110611-3	1	14.85	(1.38)	27 1/4"	(692)	78 7/16"	(1992)	54.44	(5.05)	57.85	(5.37)	14.85	(1.38)	80.66	(7.49)
FWGD/FWGED1510611-4	2	43.07	(4.00)	79 1/16"	(2008)	78 7/16"	(1992)	72.07	(6.69)	76.58	(7.11)	43.07	(4.00)	108.12	(10.04)
FWGD/FWGED5080	1	13.52	(1.26)	21 1/4"	(540)	91 1/2"	(2324)	23.31	(2.16)	24.52	(2.27)	13.52	(1.26)	39.29	(3.65)
FWGD/FWGED6080	1	17.33	(1.61)	27 1/4"	(692)	91 1/2"	(2324)	29.93	(2.78)	31.49	(2.92)	17.33	(1.61)	47.25	(4.39)
FWGD/FWGED7080	1	21.15	(1.96)	33 1/4"	(845)	91 1/2"	(2324)	36.55	(3.39)	38.45	(3.57)	21.15	(1.96)	55.21	(5.13)
FWGD/FWGED8080	1	24.96	(2.32)	39 1/4"	(997)	91 1/2"	(2324)	43.17	(4.01)	45.42	(4.21)	24.96	(2.32)	63.17	(5.87)
FWGD/FWGED91080-4	2	27.38	(2.54)	43 1/16"	(1094)	91 1/2"	(2324)	46.61	(4.33)	49.04	(4.55)	27.38	(2.54)	77.59	(7.21)
FWGD/FWGED91080-3	1	13.52	(1.26)	21 1/4"	(540)	91 1/2"	(2324)	51.97	(4.82)	54.69	(5.08)	13.52	(1.26)	77.59	(7.21)
FWGD/FWGED111080-4	2	35.01	(3.25)	55 1/16"	(1399)	91 1/2"	(2324)	59.85	(5.56)	62.98	(5.85)	35.01	(3.25)	93.51	(8.69)
FWGD/FWGED111080-3	1	17.33	(1.61)	27 1/4"	(692)	91 1/2"	(2324)	65.21	(6.05)	68.62	(6.37)	17.33	(1.61)	93.51	(8.69)
FWGD/FWGED151080-4	2	50.27	(4.67)	79 1/16"	(2008)	91 1/2"	(2324)	86.33	(8.02)	90.84	(8.43)	50.27	(4.67)	125.34	(11.64)
FWGD/FWGED50100	1	17.04	(1.58)	21 1/4"	(540)	115 1/2"	(2934)	30.35	(2.81)	31.56	(2.93)	17.04	(1.58)	49.17	(4.57)
FWGD/FWGED60100	1	21.86	(2.03)	27 1/4"	(692)	115 1/2"	(2934)	38.97	(3.62)	40.53	(3.76)	21.86	(2.03)	59.13	(5.49)
FWGD/FWGED70100	1	26.67	(2.48)	33 1/4"	(845)	115 1/2"	(2934)	47.59	(4.42)	49.49	(4.59)	26.67	(2.48)	69.09	(6.42)
FWGD/FWGED80100	1	31.48	(2.93)	39 1/4"	(997)	115 1/2"	(2934)	56.21	(5.22)	58.46	(5.43)	31.48	(2.93)	79.04	(7.34)
FWGD/FWGED910100-4	2	34.54	(3.21)	43 1/16"	(1094)	115 1/2"	(2934)	60.69	(5.63)	63.13	(5.86)	34.54	(3.21)	97.09	(9.02)
FWGD/FWGED910100-3	1	17.04	(1.58)	21 1/4"	(540)	115 1/2"	(2934)	67.68	(6.28)	70.39	(6.53)	17.04	(1.58)	97.09	(9.02)
FWGD/FWGED1110100-4	2	44.16	(4.10)	55 1/16"	(1399)	115 1/2"	(2934)	77.93	(7.23)	81.06	(7.53)	44.16	(4.10)	117.01	(10.87)
FWGD/FWGED1110100-3	1	21.86	(2.03)	27 1/4"	(692)	115 1/2"	(2934)	84.92	(7.88)	88.32	(8.20)	21.86	(2.03)	117.01	(10.87)
FWGD/FWGED1510100-4	2	63.41	(5.89)	79 1/16"	(2008)	115 1/2"	(2934)	112.41	(10.44)	116.92	(10.86)	63.41	(5.89)	156.84	(14.57)

*Dimensions in parentheses are in millimeters or square meters.

Grille Patterns

	Queen Anne	Diamond	Prairie A	Colonial	Modified Colonial	Modified Colonial with Simulated Check Rail	Tall Fractional	Tall Fractional with Simulated Check Rail	Short Fractional	Short Fractional with Simulated Check Rail
Gliding Patio Doors Traditional Panels										
Gliding Patio Doors Contemporary Panels										

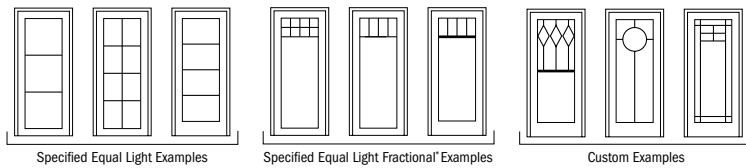

Number of lights and overall pattern varies with patio door size. Patterns may not be available in all configuration or sizes.
Specified equal light, specified equal light fractional and custom patterns are also available. For more grille options, see page 19 or visit andersenwindows.com/grilles.

*Bottom horizontal bar located at center or at custom dimensions.

Drop-Nose Channel

Optional drop-nose channel is available when higher product performance is required. Wood and concrete installations shown.

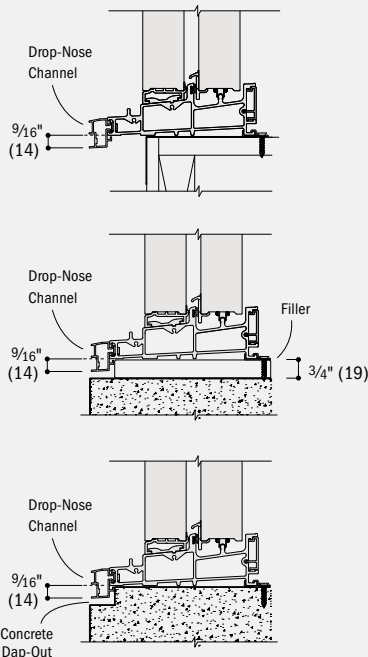

Remodeler Sill Bracket

Optional remodeler sill bracket is available for installation with an existing finished interior floor.

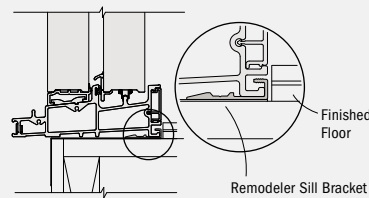

*Dimensions in parentheses are in millimeters.

GLIDING PATIO DOORS

Gliding Patio Door Details - Traditional Panels

Scale 1 1/2" (38) = 1'-0" (305) - 1:8

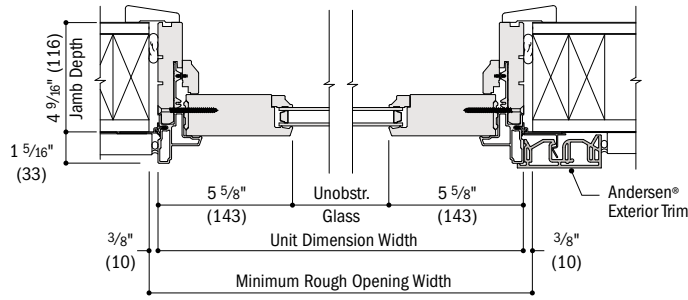

Horizontal Section
Stationary, Traditional Panel

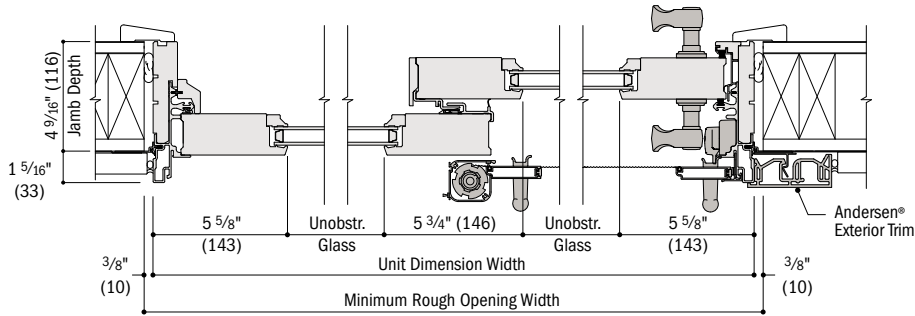

Horizontal Section
Two-Panel, Traditional Panels, Retractable Insect Screen

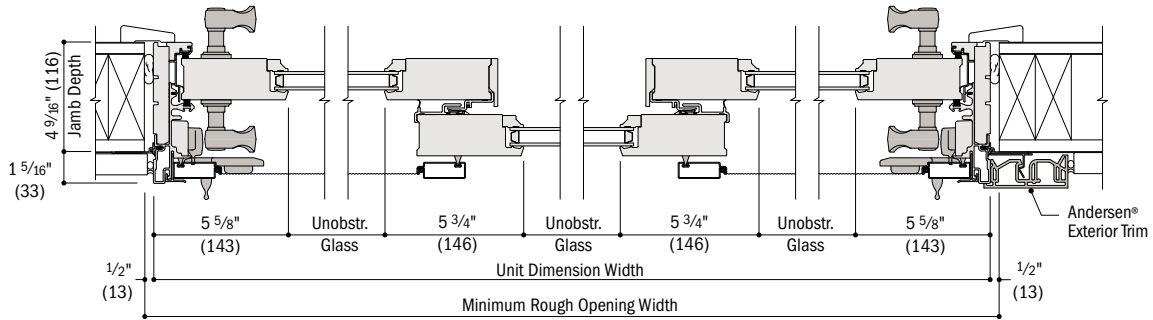

Horizontal Section
Three-Panel, Traditional Panels, Top-Hung Gliding or Gliding Insect Screen

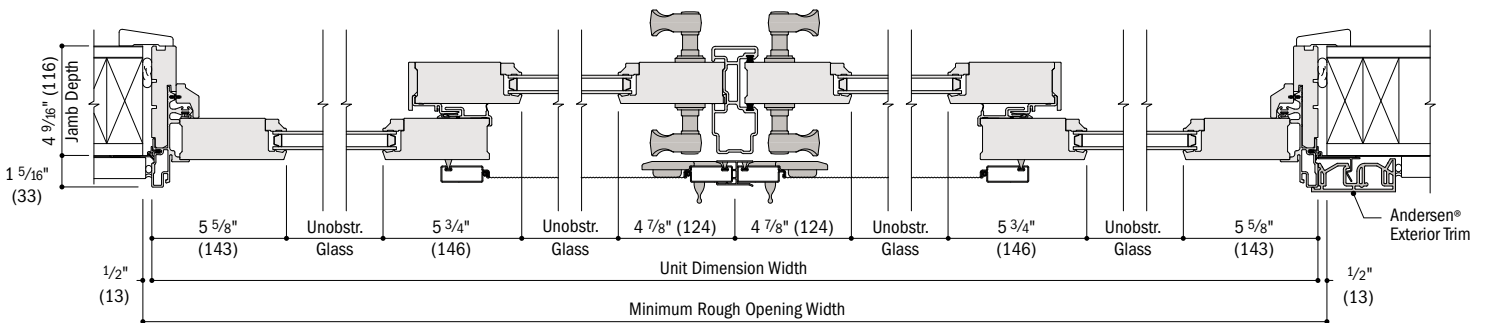

Horizontal Section
Four-Panel, Traditional Panels, Top-Hung Gliding or Gliding Insect Screen

continued on next page

- 4 9/16" (116) base jamb depth measurement is from back side of installation flange.
- Light-colored areas are parts included with door. Dark-colored areas are additional Andersen® parts required to complete door assembly as shown.
- **Minimum rough openings may need to be increased to allow for use of building wraps, flashing, sill panning, brackets, fasteners or other items. See installation information on pages 226-227.**
- Details are for illustration only and are not intended to represent product installation methods or materials. Refer to product installation instructions at andersenwindows.com.
- Dimensions in parentheses are in millimeters.
- Additional hardware options are available, including flush mount hardware.

Gliding Patio Door Details – Traditional Panels (continued)

Scale 1 1/2" (38) = 1'-0" (305) – 1:8

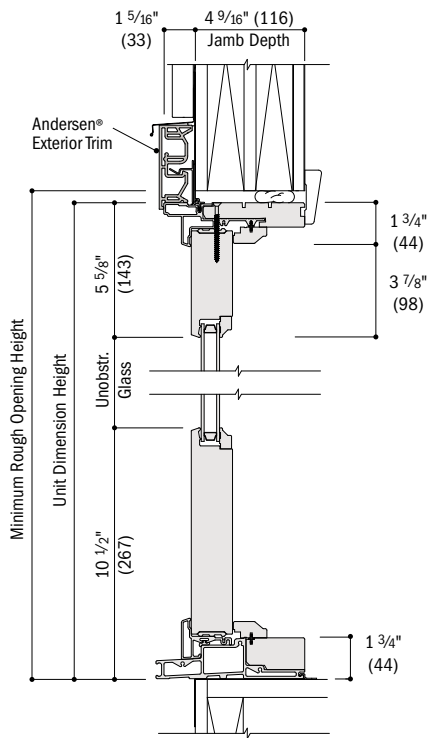

Vertical Section
Stationary, Traditional Panel

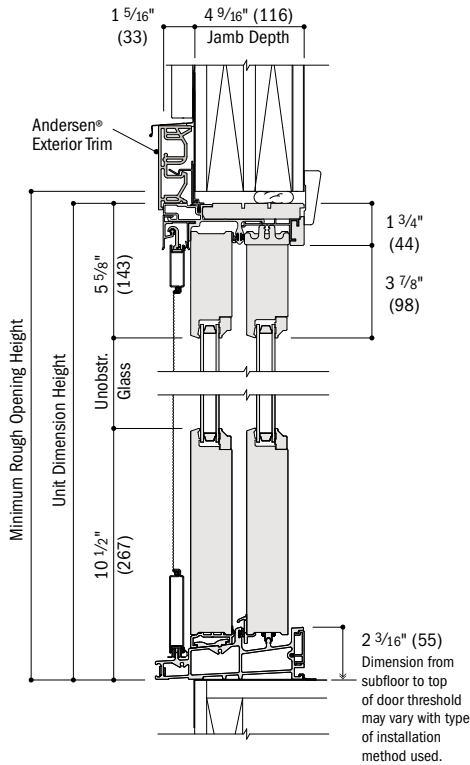

Vertical Section
Operating, Traditional Panels, Top-Hung Gliding Insect Screen

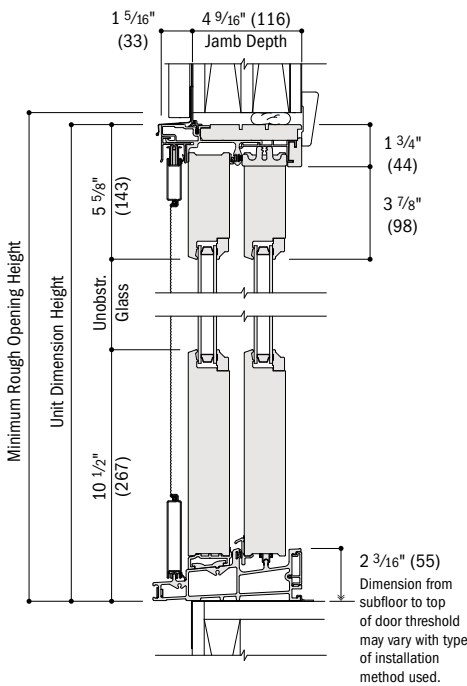

Vertical Section
Operating, Traditional Panels, Gliding Insect Screen

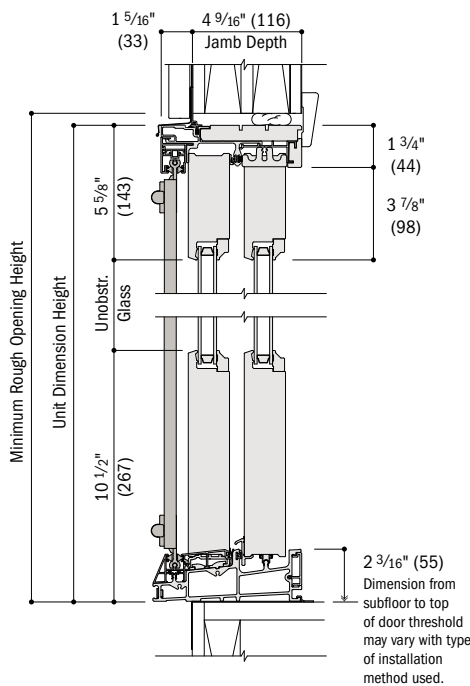

Vertical Section
Operating, Traditional Panels, Retractable Insect Screen

For optional drop-nose channel and remodeler sill bracket details, see page 129.
See pages 168-171 for joining details.

- 4 9/16" (116) base jamb depth measurement is from back side of installation flange.
- Light-colored areas are parts included with door. Dark-colored areas are additional Andersen® parts required to complete door assembly as shown.
- **Minimum rough openings may need to be increased to allow for use of building wraps, flashing, sill panning, brackets, fasteners or other items. See installation information on pages 226-227.**
- Details are for illustration only and are not intended to represent product installation methods or materials. Refer to product installation instructions at andersenwindows.com.
- Dimensions in parentheses are in millimeters.

GLIDING PATIO DOORS

Gliding Patio Door Details - Contemporary Panels

Scale 1 1/2" (38) = 1'-0" (305) - 1:8

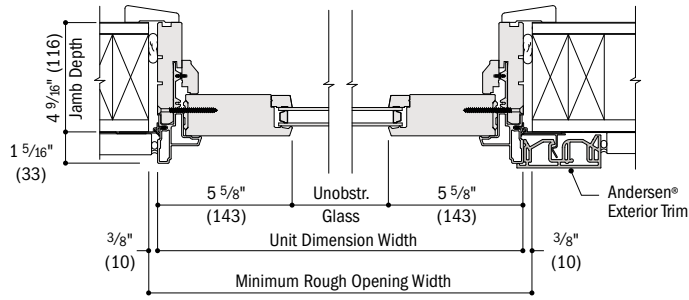

Horizontal Section
Stationary, Contemporary Panel

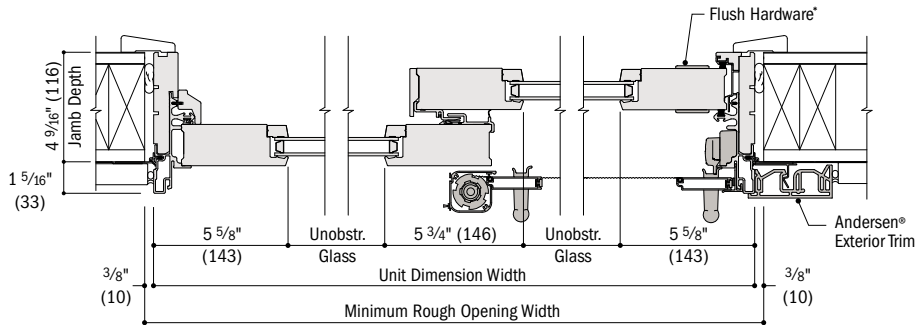

Horizontal Section
Two-Panel, Contemporary Panels, Retractable Insect Screen

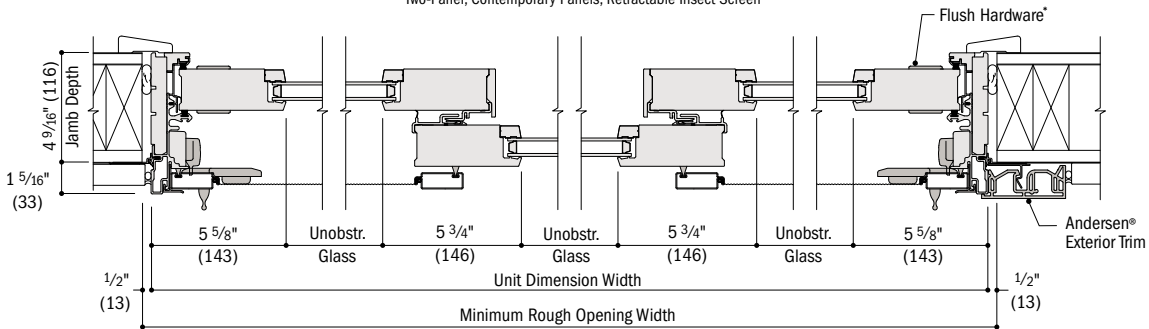

Horizontal Section
Three-Panel, Contemporary Panels, Top-Hung Gliding or Gliding Insect Screen

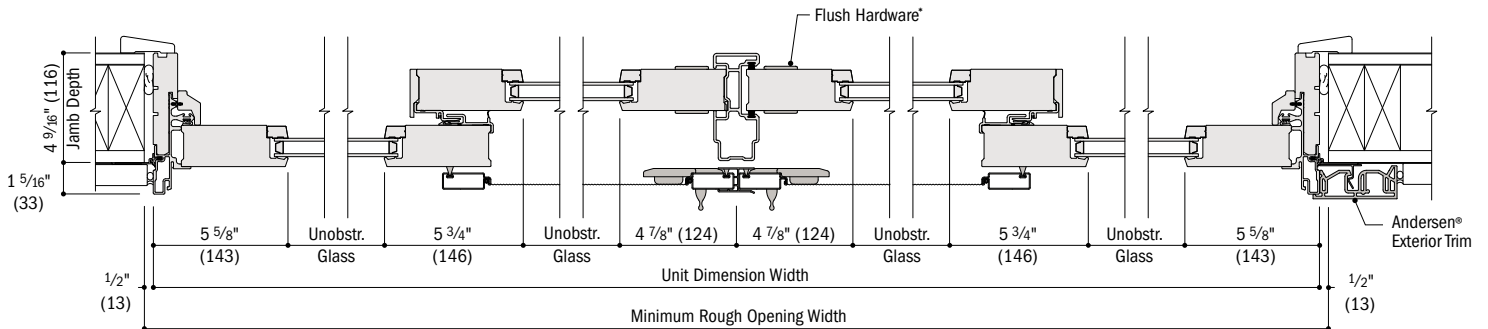

Horizontal Section
Four-Panel, Contemporary Panels, Top-Hung Gliding or Gliding Insect Screen

continued on next page

- 4 9/16" (116) base jamb depth measurement is from back side of installation flange.
- Light-colored areas are parts included with door. Dark-colored areas are additional Andersen® parts required to complete door assembly as shown.
- **Minimum rough openings may need to be increased to allow for use of building wraps, flashing, sill panning, brackets, fasteners or other items. See installation information on pages 226-227.**
- Details are for illustration only and are not intended to represent product installation methods or materials. Refer to product installation instructions at andersenwindows.com.
- Dimensions in parentheses are in millimeters.
- Flush hardware shown. Additional hardware options are available.

Gliding Patio Door Details – Contemporary Panels (continued)

Scale 1 1/2" (38) = 1'-0" (305) – 1:8

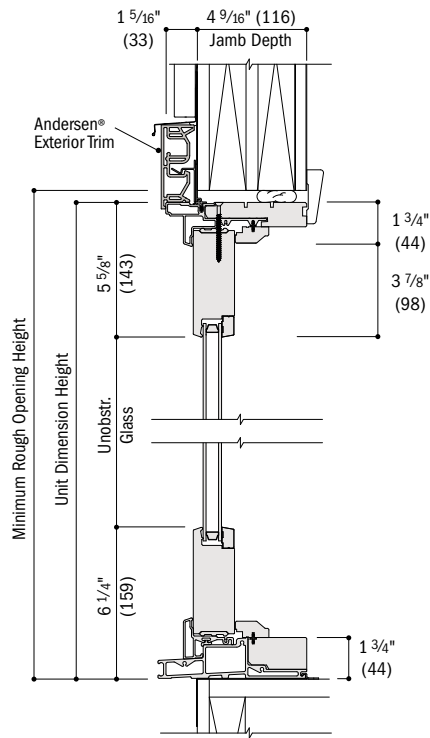

Vertical Section
Stationary, Contemporary Panel

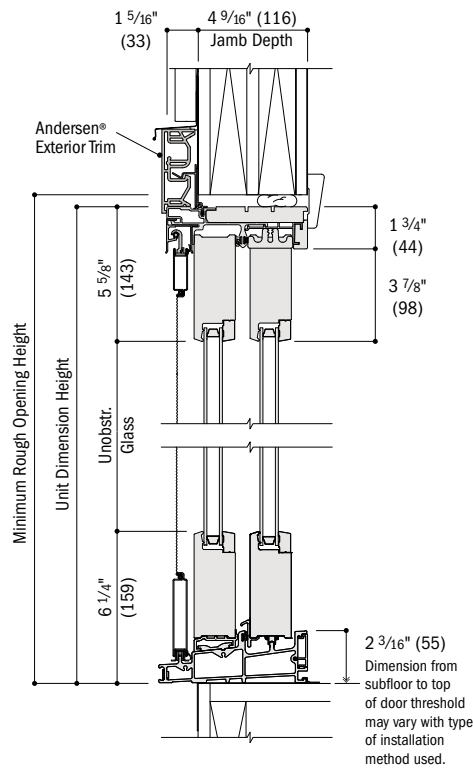

Vertical Section
Operating, Contemporary Panels, Top-Hung Gliding Insect Screen

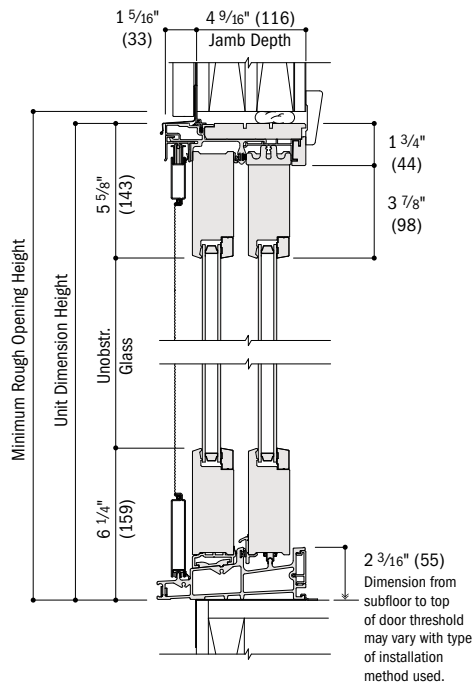

Vertical Section
Operating, Contemporary Panels, Gliding Insect Screen

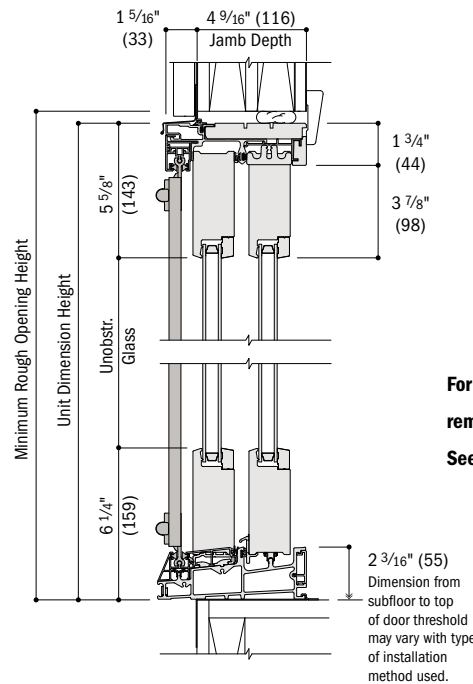

Vertical Section
Operating, Contemporary Panels, Retractable Insect Screen

For optional drop-nose channel and remodeler sill bracket details, see page 129.
See pages 168-171 for joining details.

- 4 9/16" (116) base jamb depth measurement is from back side of installation flange.
- Light-colored areas are parts included with door. Dark-colored areas are additional Andersen® parts required to complete door assembly as shown.
- **Minimum rough openings may need to be increased to allow for use of building wraps, flashing, sill panning, brackets, fasteners or other items. See installation information on pages 226-227.**
- Details are for illustration only and are not intended to represent product installation methods or materials. Refer to product installation instructions at andersenwindows.com.
- Dimensions in parentheses are in millimeters.

HINGED INSWING PATIO DOORS

Table of Hinged Inswing Patio Door Sizes

Notes on the next page also apply to this page.

Scale 1/8" (3) = 1'-0" (305) – 1:96

Door Dimension	2'-0 1/8" (612)	3'-11 1/4" (1200)	3'-11 1/4" (1200)	2'-6 1/8" (764)	2'-6 1/8" (764)	2'-6 1/8" (764)	4'-11 1/4" (1505)	4'-11 1/4" (1505)	4'-11 1/4" (1505)
Minimum Rough Opening	2'-1" (634)	4'-0" (1219)	4'-0" (1219)	2'-7" (787)	2'-7" (787)	2'-7" (787)	5'-0" (1524)	5'-0" (1524)	5'-0" (1524)
Unobstructed Glass (single panel only)	12 7/8" (327)	12 7/8" (327)	12 7/8" (327)	18 7/8" (479)	18 7/8" (479)	18 7/8" (479)	18 7/8" (479)	18 7/8" (479)	18 7/8" (479)

4 heights

1 FWHID/FWHICD	2168S*	4068SS	4068APLR/4068PALR	2768S	2768AR	2768AL	5068SS	5068ASR	5068ASL
2 FWHID/FWHICD	21611S*	40611SS	40611APLR/40611PALR	27611S	27611AR	27611AL	50611SS	50611ASR	50611ASL
3 FWHID/FWHICD	2180S*	4080SS	4080APLR/4080PALR	2780S	2780AR	2780AL	5080SS	5080ASR	5080ASL
4 FWHID/FWHICD	21100S*	40100SS	40100APLR/40100PALR	27100S	27100AR	27100AL	50100SS	50100ASR	50100ASL

Door Dimension	2'-8 1/8" (815)	2'-8 1/8" (815)	2'-8 1/8" (815)	5'-3 1/4" (1607)	5'-3 1/4" (1607)	5'-3 1/4" (1607)	5'-3 1/4" (1607)	5'-3 1/4" (1607)	5'-3 1/4" (1607)
Minimum Rough Opening	2'-9" (838)	2'-9" (838)	2'-9" (838)	5'-4" (1626)	5'-4" (1626)	5'-4" (1626)	5'-4" (1626)	5'-4" (1626)	5'-4" (1626)
Unobstructed Glass (single panel only)	20 7/8" (530)	20 7/8" (530)	20 7/8" (530)	20 7/8" (530)	20 7/8" (530)	20 7/8" (530)	20 7/8" (530)	20 7/8" (530)	20 7/8" (530)

4 heights

1 FWHID/FWHICD	2968S	2968AR	2968AL	5468SS	5468ASR	5468ASL	5468SAR	5468SAL	5468APLR/5468PALR
2 FWHID/FWHICD	29611S	29611AR	29611AL	54611SS	54611ASR	54611ASL	54611SAR	54611SAL	54611APLR/54611PALR
3 FWHID/FWHICD	2980S	2980AR	2980AL	5480SS	5480ASR	5480ASL	5480SAR	5480SAL	5480APLR/5480PALR
4 FWHID/FWHICD	29100S	29100AR	29100AL	54100SS	54100ASR	54100ASL	54100SAR	54100SAL	54100APLR/54100PALR

Door Dimension	3'-0 1/8" (917)	3'-0 1/8" (917)	3'-0 1/8" (917)	5'-11 1/4" (1810)	5'-11 1/4" (1810)	5'-11 1/4" (1810)	5'-11 1/4" (1810)	5'-11 1/4" (1810)	5'-11 1/4" (1810)
Minimum Rough Opening	3'-1" (940)	3'-1" (940)	3'-1" (940)	6'-0" (1829)	6'-0" (1829)	6'-0" (1829)	6'-0" (1829)	6'-0" (1829)	6'-0" (1829)
Unobstructed Glass (single panel only)	24 7/8" (632)	24 7/8" (632)	24 7/8" (632)	24 7/8" (632)	24 7/8" (632)	24 7/8" (632)	24 7/8" (632)	24 7/8" (632)	24 7/8" (632)

4 heights

1 FWHID/FWHICD	3168S	3168AR	3168AL	6068SS	6068ASR	6068ASL	6068SAR	6068SAL	6068APLR/6068PALR
2 FWHID/FWHICD	31611S	31611AR	31611AL	60611SS	60611ASR	60611ASL	60611SAR	60611SAL	60611APLR/60611PALR
3 FWHID/FWHICD	3180S	3180AR	3180AL	6080SS	6080ASR	6080ASL	6080SAR	6080SAL	6080APLR/6080PALR
4 FWHID/FWHICD	31100S	31100AR	31100AL	60100SS	60100ASR	60100ASL	60100SAR	60100SAL	60100APLR/60100PALR

Door Dimension	3'-2 1/8" (968)	3'-2 1/8" (968)	3'-2 1/8" (968)	6'-3 1/4" (1911)	6'-3 1/4" (1911)	6'-3 1/4" (1911)	6'-3 1/4" (1911)	6'-3 1/4" (1911)	6'-3 1/4" (1911)
Minimum Rough Opening	3'-3" (991)	3'-3" (991)	3'-3" (991)	6'-4" (1930)	6'-4" (1930)	6'-4" (1930)	6'-4" (1930)	6'-4" (1930)	6'-4" (1930)
Unobstructed Glass (single panel only)	26 7/8" (683)	26 7/8" (683)	26 7/8" (683)	26 7/8" (683)	26 7/8" (683)	26 7/8" (683)	26 7/8" (683)	26 7/8" (683)	26 7/8" (683)

4 heights

1 FWHID/FWHICD	3368S	3368AR	3368AL	6468SS	6468ASR	6468ASL	6468SAR	6468SAL	6468APLR/6468PALR
2 FWHID/FWHICD	33611S	33611AR	33611AL	64611SS	64611ASR	64611ASL	64611SAR	64611SAL	64611APLR/64611PALR
3 FWHID/FWHICD	3380S	3380AR	3380AL	6480SS	6480ASR	6480ASL	6480SAR	6480SAL	6480APLR/6480PALR
4 FWHID/FWHICD	33100S	33100AR	33100AL	64100SS	64100ASR	64100ASL	64100SAR	64100SAL	64100APLR/64100PALR

4'-11 1/4" (1505)	4'-11 1/4" (1505)	4'-11 1/4" (1505)
5'-0" (1524)	5'-0" (1524)	5'-0" (1524)
18 7/8" (479)	18 7/8" (479)	18 7/8" (479)

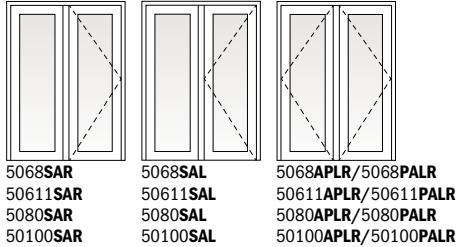

continued on the next page

- * "Door Dimension" always refers to outside frame-to-frame dimension.
- * "Minimum Rough Opening" dimensions may need to be increased to allow for use of building wraps, flashing, sill panning, brackets, fasteners or other items. See pages 226-227 for more details.
- * Dimensions in parentheses are in millimeters.
- * Single-panel active left- and right-hinged patio doors, shown on page 134, also available. Contact your Andersen supplier for more information.



Custom-size doors are available in 1/8" (3) increments. See pages 173 and 175 for custom sizes, specifications and information on shipping patio doors greater than 8' (2438).

Choose traditional (FWHID) or contemporary (FWHICD) panels. Contemporary panels shown. Stationary (S) patio doors can be used as an individual door or a sidelight. Inswing doors are available in both 4 9/16" (116) and 6 9/16" (167) base jamb depths.

Grille patterns shown on page 140. Details shown on pages 141-149.

Four Patio Door Heights

Traditional Panels

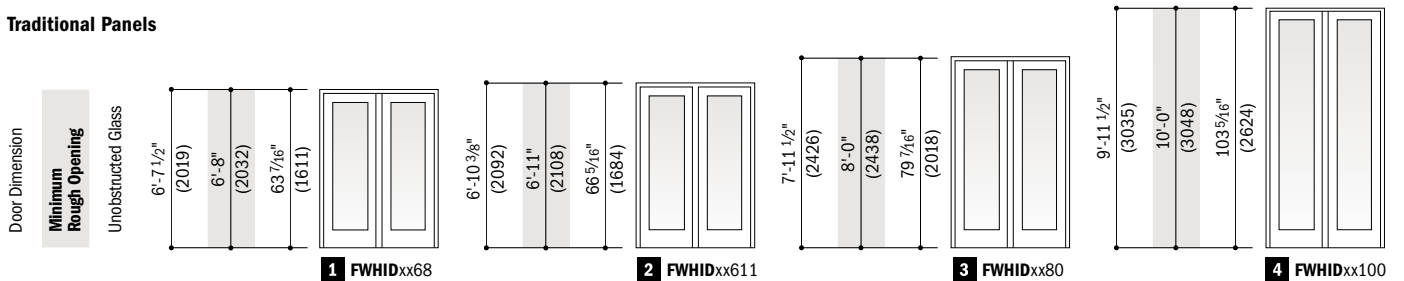

Contemporary Panels

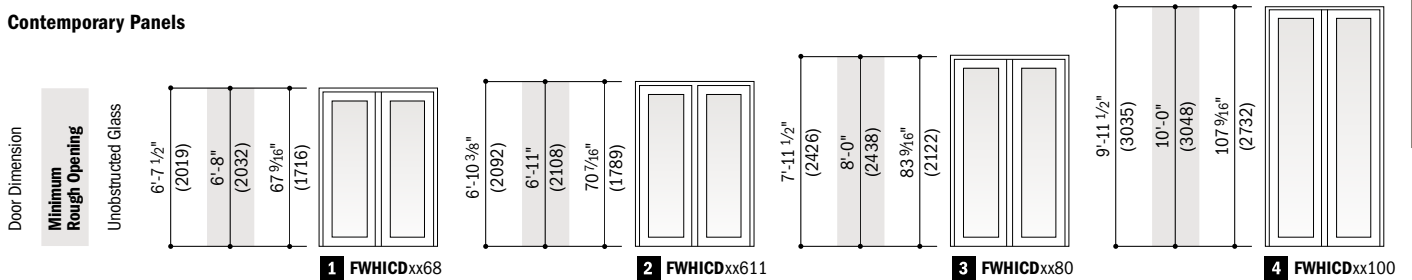

Order Designation Description Viewed from the exterior. Traditional panels shown.

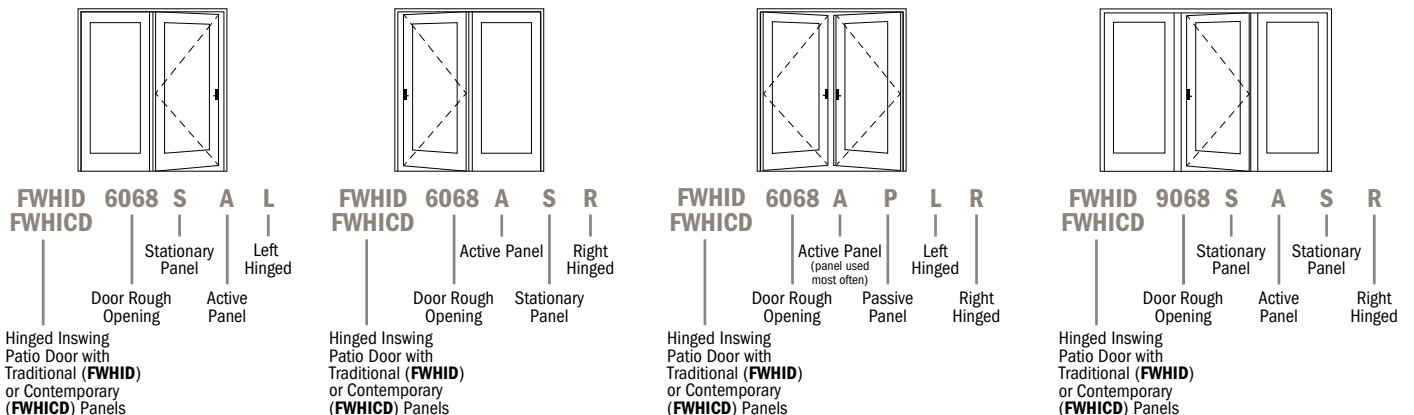

A-Series Hinged Inswing Patio Doors

HINGED INSWING PATIO DOORS

Table of Hinged Inswing Patio Door Sizes (continued)

Scale 1/8" (3) = 1'-0" (305) – 1:96

Door Dimension	7'-10 7/16" (2398)	7'-10 7/16" (2398)	7'-10 7/16" (2398)	7'-10 7/16" (2398)	7'-10 7/16" (2398)	7'-10 7/16" (2398)
Minimum Rough Opening	7'-11" (2413)	7'-11" (2413)	7'-11" (2413)	7'-11" (2413)	7'-11" (2413)	7'-11" (2413)
Unobstructed Glass (single panel only)	20 7/8" (530)	20 7/8" (530)	20 7/8" (530)	20 7/8" (530)	20 7/8" (530)	20 7/8" (530)

1 FWHID/FWHICD	71168SSS-3	71168ASSR-3	71168ASSL-3	71168SASR-3	71168SASL-3	71168SSAR-3
2 FWHID/FWHICD	711611SSS-3	711611ASSR-3	711611ASSL-3	711611SASR-3	711611SASL-3	711611SAR-3
3 FWHID/FWHICD	71180SSS-3	71180ASSR-3	71180SASSL-3	71180SASR-3	71180SASL-3	71180SSAR-3
4 FWHID/FWHICD	711100SSS-3	711100ASSR-3	711100SASSL-3	711100SASR-3	711100SASL-3	711100SAR-3

Door Dimension	8'-10 7/16" (2703)	8'-10 7/16" (2703)	8'-10 7/16" (2703)	8'-10 7/16" (2703)	8'-10 7/16" (2703)
Minimum Rough Opening	8'-11" (2717)	8'-11" (2717)	8'-11" (2717)	8'-11" (2717)	8'-11" (2717)
Unobstructed Glass (single panel only)	24 7/8" (632)	24 7/8" (632)	24 7/8" (632)	24 7/8" (632)	24 7/8" (632)

1 FWHID/FWHICD	81168SSS-3	81168ASSR-3	81168ASSL-3	81168SASR-3	81168SASL-3
2 FWHID/FWHICD	811611SSS-3	811611ASSR-3	811611ASSL-3	811611SASR-3	811611SASL-3
3 FWHID/FWHICD	81180SSS-3	81180ASSR-3	81180SASSL-3	81180SASR-3	81180SASL-3
4 FWHID/FWHICD	811100SSS-3	811100ASSR-3	811100SASSL-3	811100SASR-3	811100SASL-3

Door Dimension	9'-4 7/16" (2856)	9'-4 7/16" (2856)	9'-4 7/16" (2856)	9'-4 7/16" (2856)	9'-4 7/16" (2856)
Minimum Rough Opening	9'-5" (2870)	9'-5" (2870)	9'-5" (2870)	9'-5" (2870)	9'-5" (2870)
Unobstructed Glass (single panel only)	26 7/8" (683)	26 7/8" (683)	26 7/8" (683)	26 7/8" (683)	26 7/8" (683)

1 FWHID/FWHICD	9668SSS-3	9668ASSR-3	9668ASSL-3	9668SASR-3	9668SASL-3
2 FWHID/FWHICD	96611SSS-3	96611ASSR-3	96611ASSL-3	96611SASR-3	96611SASL-3
3 FWHID/FWHICD	9680SSS-3	9680ASSR-3	9680ASSL-3	9680SASR-3	9680SASL-3
4 FWHID/FWHICD	96100SSS-3	96100ASSR-3	96100ASSL-3	96100SASR-3	96100SASL-3



Custom-size doors are available in 1/8" (3) increments.

See pages 173 and 175 for custom sizes, specifications and information on shipping patio doors greater than 8' (2438).

Choose traditional (**FWHID**) or contemporary (**FWHICD**) panels. Contemporary panels shown.

Stationary (**S**) patio doors can be used as an individual door or as a sidelight. Inswing doors are available in both 4 9/16" (116) and 6 9/16" (167) base jamb depths. Grille patterns shown on page 140. Details shown on pages 141-149.

* "Door Dimension" always refers to outside frame-to-frame dimension.

* "Minimum Rough Opening" dimensions may need to be increased to allow for use of building wraps, flashing, sill panning, brackets, fasteners or other items. See pages 226-227 for more details.

* Dimensions in parentheses are in millimeters.

Notes on the previous page also apply to this page.

7'-10 7/16" (2398)	7'-10 7/16" (2398)	7'-10 7/16" (2398)	7'-10 7/16" (2398)	7'-10 7/16" (2398)
7'-11" (2413)	7'-11" (2413)	7'-11" (2413)	7'-11" (2413)	7'-11" (2413)
20 7/8" (530)	20 7/8" (530)	20 7/8" (530)	20 7/8" (530)	20 7/8" (530)

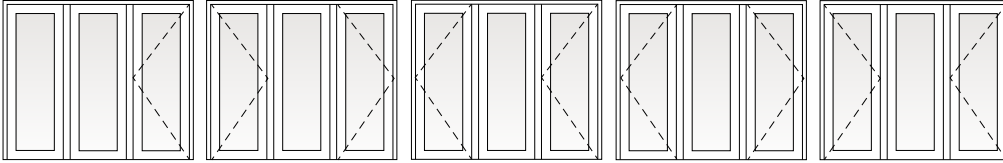

71168SSAL-3	71168ASARR-3	71168ASALL-3	71168ASALR-3	71168ASARL-3
711611SSAL-3	711611ASARR-3	711611ASALL-3	711611ASALR-3	711611ASARL-3
71180SSAL-3	71180ASARR-3	71180ASALL-3	71180ASALR-3	71180ASARL-3
711100SSAL-3	711100ASARR-3	711100ASALL-3	711100ASALR-3	711100ASARL-3

8'-10 7/16" (2703)	8'-10 7/16" (2703)	8'-10 7/16" (2703)	8'-10 7/16" (2703)	8'-10 7/16" (2703)	8'-10 7/16" (2703)
8'-11" (2717)	8'-11" (2717)	8'-11" (2717)	8'-11" (2717)	8'-11" (2717)	8'-11" (2717)
24 7/8" (632)	24 7/8" (632)	24 7/8" (632)	24 7/8" (632)	24 7/8" (632)	24 7/8" (632)

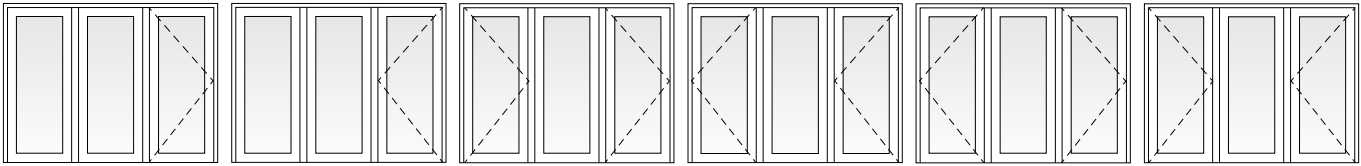

81168SSAR-3	81168SSAL-3	81168ASARR-3	81168ASALL-3	81168ASALR-3	81168ASARL-3
811611SSAR-3	811611SSAL-3	811611ASARR-3	811611ASALL-3	811611ASALR-3	811611ASARL-3
81180SSAR-3	81180SSAL-3	81180ASARR-3	81180ASALL-3	81180ASALR-3	81180ASARL-3
811100SSAR-3	811100SSAL-3	811100ASARR-3	811100ASALL-3	811100ASALR-3	811100ASARL-3

9'-4 7/16" (2856)	9'-4 7/16" (2856)	9'-4 7/16" (2856)	9'-4 7/16" (2856)	9'-4 7/16" (2856)	9'-4 7/16" (2856)
9'-5" (2870)	9'-5" (2870)	9'-5" (2870)	9'-5" (2870)	9'-5" (2870)	9'-5" (2870)
26 7/8" (683)	26 7/8" (683)	26 7/8" (683)	26 7/8" (683)	26 7/8" (683)	26 7/8" (683)

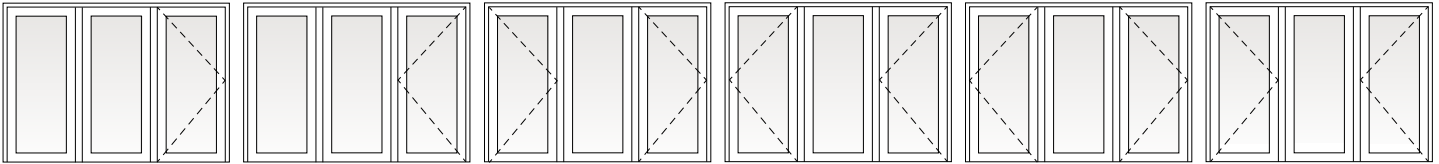

9668SSAR-3	9668SSAL-3	9668ASARR-3	9668ASALL-3	9668ASALR-3	9668ASARL-3
96611SSAR-3	96611SSAL-3	96611ASARR-3	96611ASALL-3	96611ASALR-3	96611ASARL-3
9680SSAR-3	9680SSAL-3	9680ASARR-3	9680ASALL-3	9680ASALR-3	9680ASARL-3
96100SSAR-3	96100SSAL-3	96100ASARR-3	96100ASALL-3	96100ASALR-3	96100ASARL-3

* "Door Dimension" always refers to outside frame-to-frame dimension.
 • "Minimum Rough Opening" dimensions may need to be increased to allow for use of building wraps, flashing, sill panning, brackets, fasteners or other items. See pages 226-227 for more details.
 • Dimensions in parentheses are in millimeters.

HINGED INSWING PATIO DOORS

Hinged Inswing Patio Door Opening and Area Specifications

Door Number	Number of Panels in Open Position*	Clear Opening Area Sq. Ft./ (m ²)		Clear Opening Maximums			Traditional Panel Glass Area Sq. Ft./ (m ²)	Contemporary Panel Glass Area Sq. Ft./ (m ²)	Vent Area Sq. Ft./ (m ²)	Overall Door Area Sq. Ft./ (m ²)
				90° Width Inches/ (mm)	Full Width Inches/ (mm)	Height Inches/ (mm)				
FWHID/FWHICD2168S**	1	10.43 (0.97)	18 5/16" (465)	20" (508)	75 1/2" (1918)	5.66 (0.53)	6.04 (0.56)	10.43 (0.97)	13.30 (1.24)	
FWHID/FWHICD2768	1	13.57 (1.26)	24 5/16" (618)	26" (660)	75 1/2" (1918)	8.30 (0.77)	8.85 (0.82)	13.57 (1.26)	16.61 (1.54)	
FWHID/FWHICD2968	1	14.62 (1.36)	26 5/16" (668)	28" (711)	75 1/2" (1918)	9.18 (0.85)	9.79 (0.91)	14.62 (1.36)	17.72 (1.65)	
FWHID/FWHICD3168	1	16.71 (1.55)	30 5/16" (770)	32" (813)	75 1/2" (1918)	10.94 (1.02)	11.66 (1.08)	16.71 (1.55)	19.93 (1.85)	
FWHID/FWHICD3368	1	17.75 (1.65)	32 5/16" (821)	34" (864)	75 1/2" (1918)	11.82 (1.10)	12.60 (1.17)	17.75 (1.65)	21.03 (1.95)	
FWHID/FWHICD4068	2	22.54 (2.09)	18 5/16" (465)	43 1/8" (1095)	75 1/2" (1918)	11.34 (1.05)	12.08 (1.12)	22.54 (2.09)	26.09 (2.42)	
FWHID/FWHICD4068	1	10.43 (0.97)	18 5/16" (465)	20" (508)	75 1/2" (1918)	11.34 (1.05)	12.08 (1.12)	10.43 (0.97)	26.09 (2.42)	
FWHID/FWHICD5068	1 AS/SA	13.57 (1.26)	24 5/16" (618)	26" (660)	75 1/2" (1918)	16.63 (1.54)	17.71 (1.65)	13.57 (1.26)	32.71 (3.04)	
FWHID/FWHICD5068	2 AP/PA	28.81 (2.68)	24 5/16" (618)	55 1/8" (1400)	75 1/2" (1918)	16.63 (1.54)	17.71 (1.65)	28.81 (2.68)	32.71 (3.04)	
FWHID/FWHICD5068	1 AP/PA	13.57 (1.26)	24 5/16" (618)	26" (660)	75 1/2" (1918)	16.63 (1.54)	17.71 (1.65)	13.57 (1.26)	32.71 (3.04)	
FWHID/FWHICD5468	1 AS/SA	14.62 (1.36)	26 5/16" (668)	28" (711)	75 1/2" (1918)	18.39 (1.71)	19.59 (1.82)	14.62 (1.36)	34.92 (3.24)	
FWHID/FWHICD5468	2 AP/PA	30.90 (2.87)	26 5/16" (668)	59 1/8" (1502)	75 1/2" (1918)	18.39 (1.71)	19.59 (1.82)	30.90 (2.87)	34.92 (3.24)	
FWHID/FWHICD5468	1 AP/PA	14.61 (1.36)	26 5/16" (668)	28" (711)	75 1/2" (1918)	18.39 (1.71)	19.59 (1.82)	14.61 (1.36)	34.92 (3.24)	
FWHID/FWHICD6068	1 AS/SA	16.71 (1.55)	30 5/16" (770)	32" (813)	75 1/2" (1918)	21.92 (2.04)	23.34 (2.17)	16.71 (1.55)	39.34 (3.65)	
FWHID/FWHICD6068	2 AP/PA	35.08 (3.26)	30 5/16" (770)	67 1/8" (1705)	75 1/2" (1918)	21.92 (2.04)	23.34 (2.17)	35.08 (3.26)	39.34 (3.65)	
FWHID/FWHICD6068	1 AP/PA	16.71 (1.55)	30 5/16" (770)	32" (813)	75 1/2" (1918)	21.92 (2.04)	23.34 (2.17)	16.71 (1.55)	39.34 (3.65)	
FWHID/FWHICD6468	1 AS/SA	17.75 (1.65)	32 5/16" (821)	34" (864)	75 1/2" (1918)	23.68 (2.20)	25.22 (2.34)	17.75 (1.65)	41.54 (3.86)	
FWHID/FWHICD6468	2 AP/PA	37.17 (3.45)	32 5/16" (821)	71 1/8" (1806)	75 1/2" (1918)	23.68 (2.20)	25.22 (2.34)	37.17 (3.45)	41.54 (3.86)	
FWHID/FWHICD6468	1 AP/PA	17.75 (1.65)	32 5/16" (821)	34" (864)	75 1/2" (1918)	23.68 (2.20)	25.22 (2.34)	17.75 (1.65)	41.54 (3.86)	
FWHID/FWHICD71168-3	1 ASS/SAS/SSA/ASA	14.62 (1.36)	26 5/16" (668)	28" (711)	75 1/2" (1918)	27.59 (2.56)	29.40 (2.73)	14.62 (1.36)	52.12 (4.84)	
FWHID/FWHICD71168-3	2 ASA	14.62 (1.36)	26 5/16" (668)	28" (711)	75 1/2" (1918)	27.59 (2.56)	29.40 (2.73)	29.24 (2.72)	52.12 (4.84)	
FWHID/FWHICD81168-3	1 ASS/SAS/SSA/ASA	16.71 (1.55)	30 5/16" (770)	32" (813)	75 1/2" (1918)	32.87 (3.05)	35.03 (3.25)	16.71 (1.55)	58.74 (5.46)	
FWHID/FWHICD81168-3	2 ASA	16.71 (1.55)	30 5/16" (770)	32" (813)	75 1/2" (1918)	32.87 (3.05)	35.03 (3.25)	33.42 (3.10)	58.74 (5.46)	
FWHID/FWHICD9668-3	1 ASS/SAS/SSA/ASA	17.75 (1.65)	32 5/16" (821)	34" (864)	75 1/2" (1918)	35.52 (3.30)	37.84 (3.52)	17.75 (1.65)	62.06 (5.77)	
FWHID/FWHICD9668-3	2 ASA	17.75 (1.65)	32 5/16" (821)	34" (864)	75 1/2" (1918)	35.52 (3.30)	37.84 (3.52)	35.50 (3.30)	62.06 (5.77)	
FWHID/FWHICD21611S**	1	10.83 (1.01)	18 5/16" (465)	20" (508)	78 1/8" (1984)	5.92 (0.55)	6.29 (0.58)	10.83 (1.01)	13.78 (1.28)	
FWHID/FWHICD27611	1	14.09 (1.31)	24 5/16" (618)	26" (660)	78 1/8" (1984)	8.68 (0.81)	9.23 (0.86)	14.09 (1.31)	17.22 (1.60)	
FWHID/FWHICD29611	1	15.17 (1.41)	26 5/16" (668)	28" (711)	78 1/8" (1984)	9.60 (0.89)	10.20 (0.95)	15.17 (1.41)	18.36 (1.71)	
FWHID/FWHICD31611	1	17.34 (1.61)	30 5/16" (770)	32" (813)	78 1/8" (1984)	11.44 (1.06)	12.16 (1.13)	17.34 (1.61)	20.65 (1.92)	
FWHID/FWHICD33611	1	18.43 (1.71)	32 5/16" (821)	34" (864)	78 1/8" (1984)	12.36 (1.15)	13.14 (1.22)	18.43 (1.71)	21.79 (2.02)	
FWHID/FWHICD40611	2	23.40 (2.17)	18 5/16" (465)	43 1/8" (1095)	78 1/8" (1984)	11.86 (1.10)	12.60 (1.17)	23.40 (2.17)	27.03 (2.51)	
FWHID/FWHICD40611	1	10.83 (1.01)	18 5/16" (465)	20" (508)	78 1/8" (1984)	11.86 (1.10)	12.60 (1.17)	10.83 (1.01)	27.03 (2.51)	
FWHID/FWHICD50611	1 AS/SA	14.09 (1.31)	24 5/16" (618)	26" (660)	78 1/8" (1984)	17.38 (1.61)	18.46 (1.71)	14.09 (1.31)	33.89 (3.15)	
FWHID/FWHICD50611	2 AP/PA	29.91 (2.78)	24 5/16" (618)	55 1/8" (1400)	78 1/8" (1984)	17.38 (1.61)	18.46 (1.71)	29.91 (2.78)	33.89 (3.15)	
FWHID/FWHICD50611	1 AP/PA	14.09 (1.31)	24 5/16" (618)	26" (660)	78 1/8" (1984)	17.38 (1.61)	18.46 (1.71)	14.09 (1.31)	33.89 (3.15)	
FWHID/FWHICD54611	1 AS/SA	15.17 (1.41)	26 5/16" (668)	28" (711)	78 1/8" (1984)	19.23 (1.79)	20.42 (1.90)	15.17 (1.41)	36.18 (3.36)	
FWHID/FWHICD54611	2 AP/PA	32.08 (2.98)	26 5/16" (668)	59 1/8" (1502)	78 1/8" (1984)	19.23 (1.79)	20.42 (1.90)	32.08 (2.98)	36.18 (3.36)	
FWHID/FWHICD54611	1 AP/PA	15.17 (1.41)	26 5/16" (668)	28" (711)	78 1/8" (1984)	19.23 (1.79)	20.42 (1.90)	15.17 (1.41)	36.18 (3.36)	
FWHID/FWHICD60611	1 AS/SA	17.34 (1.61)	30 5/16" (770)	32" (813)	78 1/8" (1984)	22.91 (2.13)	24.33 (2.26)	17.34 (1.61)	40.76 (3.79)	
FWHID/FWHICD60611	2 AP/PA	36.42 (3.38)	30 5/16" (770)	67 1/8" (1705)	78 1/8" (1984)	22.91 (2.13)	24.33 (2.26)	36.42 (3.38)	40.76 (3.79)	
FWHID/FWHICD60611	1 AP/PA	17.34 (1.61)	30 5/16" (770)	32" (813)	78 1/8" (1984)	22.91 (2.13)	24.33 (2.26)	17.34 (1.61)	40.76 (3.79)	
FWHID/FWHICD64611	1 AS/SA	18.43 (1.71)	32 5/16" (821)	34" (864)	78 1/8" (1984)	24.75 (2.30)	26.29 (2.44)	18.43 (1.71)	43.05 (4.00)	
FWHID/FWHICD64611	2 AP/PA	38.59 (3.59)	32 5/16" (821)	71 1/8" (1806)	78 1/8" (1984)	24.75 (2.30)	26.29 (2.44)	38.59 (3.59)	43.05 (4.00)	
FWHID/FWHICD64611	1 AP/PA	18.43 (1.71)	32 5/16" (821)	34" (864)	78 1/8" (1984)	24.75 (2.30)	26.29 (2.44)	18.43 (1.71)	43.05 (4.00)	
FWHID/FWHICD711611-3	1 ASS/SAS/SSA/ASA	15.17 (1.41)	26 5/16" (668)	28" (711)	78 1/8" (1984)	28.84 (2.68)	30.65 (2.85)	15.17 (1.41)	54.00 (5.02)	
FWHID/FWHICD711611-3	2 ASA	15.17 (1.41)	26 5/16" (668)	28" (711)	78 1/8" (1984)	28.84 (2.68)	30.65 (2.85)	30.34 (2.82)	54.00 (5.02)	
FWHID/FWHICD811611-3	1 ASS/SAS/SSA/ASA	17.34 (1.61)	30 5/16" (770)	32" (813)	78 1/8" (1984)	34.36 (3.19)	36.52 (3.39)	17.34 (1.61)	60.87 (5.65)	
FWHID/FWHICD811611-3	2 ASA	17.34 (1.61)	30 5/16" (770)	32" (813)	78 1/8" (1984)	34.36 (3.19)	36.52 (3.39)	34.68 (3.22)	60.87 (5.65)	
FWHID/FWHICD96611-3	1 ASS/SAS/SSA/ASA	18.43 (1.71)	32 5/16" (821)	34" (864)	78 1/8" (1984)	37.13 (3.45)	39.45 (3.67)	18.43 (1.71)	64.30 (5.97)	
FWHID/FWHICD96611-3	2 ASA	18.43 (1.71)	32 5/16" (821)	34" (864)	78 1/8" (1984)	37.13 (3.45)	39.45 (3.67)	36.86 (3.42)	64.30 (5.97)	
FWHID/FWHICD2180S**	1	12.65 (1.18)	18 5/16" (465)	20" (508)	91 1/2" (2324)	7.09 (0.66)	7.47 (0.69)	12.65 (1.18)	15.98 (1.48)	
FWHID/FWHICD2780	1	16.46 (1.53)	24 5/16" (618)	26" (660)	91 1/2" (2324)	10.40 (0.97)	10.95 (1.02)	16.46 (1.53)	19.96 (1.85)	
FWHID/FWHICD2980	1	17.72 (1.65)	26 5/16" (668)	28" (711)	91 1/2" (2324)	11.50 (1.07)	12.11 (1.13)	17.72 (1.65)	21.28 (1.98)	
FWHID/FWHICD3180	1	20.26 (1.88)	30 5/16" (770)	32" (813)	91 1/2" (2324)	13.71 (1.27)	14.43 (1.34)	20.26 (1.88)	23.94 (2.22)	
FWHID/FWHICD3380	1	21.53 (2.00)	32 5/16" (821)	34" (864)	91 1/2" (2324)	14.81 (1.38)	15.59 (1.45)	21.53 (2.00)	25.26 (2.35)	
FWHID/FWHICD4080	2	27.33 (2.54)	18 5/16" (465)	43 1/8" (1095)	91 1/2" (2324)	14.20 (1.32)	14.94 (1.39)	27.33 (2.54)	31.34 (2.91)	
FWHID/FWHICD4080	1	12.65 (1.18)	18 5/16" (465)	20" (508)	91 1/2" (2324)	14.20 (1.32)	14.94 (1.39)	12.65 (1.18)	31.34 (2.91)	
FWHID/FWHICD5080	1 AS/SA	16.46 (1.53)	24 5/16" (618)	26" (660)	91 1/2" (1984)	20.82 (1.93)	21.91 (2.04)	16.46 (1.53)	39.29 (3.65)	

* Dimensions in parentheses are in millimeters or square meters.

** For two-panel AP/PA doors with only one panel open, clear opening is based on the active panel open and the passive panel closed.

** Active left- and right-hinged patio doors also available. Contact your Andersen supplier for more information.

continued on next page

Hinged Inswing Patio Door Opening and Area Specifications *(continued)*

Door Number	Number of Panels in Open Position*	Clear Opening Area Sq. Ft./ (m ²)	Clear Opening Maximums			Traditional Panel Glass Area Sq. Ft./ (m ²)		Contemporary Panel Glass Area Sq. Ft./ (m ²)		Vent Area Sq. Ft./ (m ²)	Overall Door Area Sq. Ft./ (m ²)
			90° Width Inches/ (mm)	Full Width Inches/ (mm)	Height Inches/ (mm)	Sq. Ft./ (m ²)	Sq. Ft./ (m ²)				
FWHID/FWHICD5080	2 AP/PA	34.93 (3.25)	24 5/16" (618)	55 1/8" (1400)	91 1/2" (2324)	20.82 (1.93)	21.91 (2.04)	34.93 (3.24)	39.29 (3.65)		
FWHID/FWHICD5080	1 AP/PA	16.45 (1.53)	24 5/16" (618)	26" (660)	91 1/2" (2324)	20.82 (1.93)	21.91 (2.04)	16.45 (1.53)	39.29 (3.65)		
FWHID/FWHICD5480	1 AS/SA	17.72 (1.65)	26 5/16" (668)	28" (711)	91 1/2" (2324)	23.03 (2.14)	24.23 (2.25)	17.72 (1.65)	41.95 (3.90)		
FWHID/FWHICD5480	2 AP/PA	37.47 (3.48)	26 5/16" (668)	59 1/8" (1502)	91 1/2" (2324)	23.03 (2.14)	24.23 (2.25)	37.47 (3.48)	41.95 (3.90)		
FWHID/FWHICD5480	1 AP/PA	17.72 (1.65)	26 5/16" (668)	28" (711)	91 1/2" (2324)	23.03 (2.14)	24.23 (2.25)	17.72 (1.65)	41.95 (3.90)		
FWHID/FWHICD6080	1 AS/SA	20.26 (1.88)	30 5/16" (770)	32" (813)	91 1/2" (2324)	27.44 (2.55)	28.88 (2.68)	20.26 (1.88)	47.25 (4.39)		
FWHID/FWHICD6080	2 AP/PA	42.54 (3.95)	30 5/16" (770)	67 1/8" (1705)	91 1/2" (2324)	27.44 (2.55)	28.88 (2.68)	42.54 (3.95)	47.25 (4.39)		
FWHID/FWHICD6080	1 AP/PA	20.26 (1.88)	30 5/16" (770)	32" (813)	91 1/2" (2324)	27.44 (2.55)	28.88 (2.68)	20.26 (1.88)	47.25 (4.39)		
FWHID/FWHICD6480	1 AS/SA	21.53 (2.00)	32 5/16" (821)	34" (864)	91 1/2" (2324)	29.65 (2.75)	31.30 (2.90)	21.53 (2.00)	49.91 (4.64)		
FWHID/FWHICD6480	2 AP/PA	45.07 (4.19)	32 5/16" (821)	71 1/8" (1806)	91 1/2" (2324)	29.65 (2.75)	31.30 (2.90)	45.07 (4.19)	49.91 (4.64)		
FWHID/FWHICD6480	1 AP/PA	21.52 (2.00)	32 5/16" (821)	34" (864)	91 1/2" (2324)	29.65 (2.75)	31.30 (2.90)	21.52 (2.00)	49.91 (4.64)		
FWHID/FWHICD71180-3	1 ASS/SAS/SSA/ASA	17.72 (1.65)	26 5/16" (668)	28" (711)	91 1/2" (2324)	34.55 (3.21)	36.35 (3.38)	17.72 (1.65)	62.61 (5.82)		
FWHID/FWHICD71180-3	2 ASA	17.72 (1.65)	26 5/16" (668)	28" (711)	91 1/2" (2324)	34.55 (3.21)	36.35 (3.38)	35.44 (3.30)	62.61 (5.82)		
FWHID/FWHICD81180-3	1 ASS/SAS/SSA/ASA	20.26 (1.88)	30 5/16" (770)	32" (813)	91 1/2" (2324)	41.17 (3.82)	43.32 (4.02)	20.26 (1.88)	70.57 (6.56)		
FWHID/FWHICD81180-3	2 ASA	20.26 (1.88)	30 5/16" (770)	32" (813)	91 1/2" (2324)	41.17 (3.82)	43.32 (4.02)	40.52 (3.76)	70.57 (6.56)		
FWHID/FWHICD9680-3	1 ASS/SAS/SSA/ASA	21.53 (2.00)	32 5/16" (821)	34" (864)	91 1/2" (2324)	44.48 (4.13)	46.80 (4.35)	21.53 (2.00)	74.55 (6.93)		
FWHID/FWHICD9680-3	2 ASA	21.53 (2.00)	32 5/16" (821)	34" (864)	91 1/2" (2324)	44.48 (4.13)	46.80 (4.35)	43.06 (4.00)	74.55 (6.93)		
FWHID/FWHICD21100S**	1	16.04 (1.49)	18 5/16" (465)	20" (508)	115 1/2" (2934)	9.24 (0.86)	9.61 (0.89)	16.04 (1.49)	20.00 (1.86)		
FWHID/FWHICD27100	1	20.85 (1.94)	24 5/16" (618)	26" (660)	115 1/2" (2934)	13.56 (1.26)	14.10 (1.31)	20.85 (1.94)	24.97 (2.32)		
FWHID/FWHICD29100	1	22.46 (2.09)	26 5/16" (668)	28" (711)	115 1/2" (2934)	15.00 (1.39)	15.60 (1.45)	22.46 (2.09)	26.63 (2.47)		
FWHID/FWHICD31100	1	25.67 (2.39)	30 5/16" (770)	32" (813)	115 1/2" (2934)	17.87 (1.66)	18.59 (1.73)	25.67 (2.39)	29.95 (2.78)		
FWHID/FWHICD33100	1	27.27 (2.53)	32 5/16" (821)	34" (864)	115 1/2" (2934)	19.31 (1.72)	20.08 (1.87)	27.27 (2.53)	31.61 (2.94)		
FWHID/FWHICD40100	2	34.59 (3.21)	18 5/16" (465)	43 1/8" (1095)	115 1/2" (2934)	18.50 (1.72)	19.23 (1.79)	34.59 (3.21)	39.21 (3.64)		
FWHID/FWHICD40100	1	16.04 (1.49)	18 5/16" (465)	20" (508)	115 1/2" (2934)	18.50 (1.72)	19.23 (1.79)	16.04 (1.49)	39.21 (3.64)		
FWHID/FWHICD50100	1 AS/SA	20.85 (1.94)	24 5/16" (618)	26" (660)	115 1/2" (2934)	27.11 (2.52)	28.20 (2.62)	20.85 (1.94)	49.17 (4.57)		
FWHID/FWHICD50100	2 AP/PA	44.21 (4.11)	24 5/16" (618)	55 1/8" (1400)	115 1/2" (2934)	27.11 (2.52)	28.20 (2.62)	44.21 (4.11)	49.17 (4.57)		
FWHID/FWHICD50100	1 AP/PA	20.85 (1.94)	24 5/16" (618)	26" (660)	115 1/2" (2934)	27.11 (2.52)	28.20 (2.62)	20.85 (1.94)	49.17 (4.57)		
FWHID/FWHICD54100	1 AS/SA	22.46 (2.09)	26 5/16" (668)	28" (711)	115 1/2" (2934)	29.99 (2.79)	31.19 (2.90)	22.46 (2.09)	52.49 (4.88)		
FWHID/FWHICD54100	2 AP/PA	47.42 (4.41)	26 5/16" (668)	59 1/8" (1502)	115 1/2" (2934)	29.99 (2.79)	31.19 (2.90)	47.42 (4.41)	52.49 (4.88)		
FWHID/FWHICD54100	1 AP/PA	22.46 (2.09)	26 5/16" (668)	28" (711)	115 1/2" (2934)	29.99 (2.79)	31.19 (2.90)	22.46 (2.09)	52.49 (4.88)		
FWHID/FWHICD60100	1 AS/SA	25.67 (2.39)	30 5/16" (770)	32" (813)	115 1/2" (2934)	35.73 (3.32)	37.17 (3.45)	25.67 (2.39)	59.13 (5.49)		
FWHID/FWHICD60100	2 AP/PA	53.84 (5.00)	30 5/16" (770)	67 1/8" (1705)	115 1/2" (2934)	35.73 (3.32)	37.17 (3.45)	53.84 (5.00)	59.13 (5.49)		
FWHID/FWHICD60100	1 AP/PA	25.67 (2.39)	30 5/16" (770)	32" (813)	115 1/2" (2934)	35.73 (3.32)	37.17 (3.45)	25.67 (2.39)	59.13 (5.49)		
FWHID/FWHICD64100	1 AS/SA	27.27 (2.53)	32 5/16" (821)	34" (864)	115 1/2" (2934)	38.61 (3.59)	40.16 (3.73)	27.27 (2.53)	62.45 (5.80)		
FWHID/FWHICD64100	2 AP/PA	57.05 (5.30)	32 5/16" (821)	71 1/8" (1806)	115 1/2" (2934)	38.61 (3.59)	40.16 (3.73)	57.05 (5.30)	62.45 (5.80)		
FWHID/FWHICD64100	1 AP/PA	27.27 (2.53)	32 5/16" (821)	34" (864)	115 1/2" (2934)	38.61 (3.59)	40.16 (3.73)	27.27 (2.53)	62.45 (5.80)		
FWHID/FWHICD711100-3	1 ASS/SAS/SSA/ASA	22.46 (2.09)	26 5/16" (668)	28" (711)	115 1/2" (2934)	44.98 (4.18)	46.79 (4.35)	22.46 (2.09)	78.34 (7.28)		
FWHID/FWHICD711100-3	2 ASA	22.46 (2.09)	26 5/16" (668)	28" (711)	115 1/2" (2934)	44.98 (4.18)	46.79 (4.35)	44.92 (4.17)	78.34 (7.28)		
FWHID/FWHICD811100-3	1 ASS/SAS/SSA/ASA	25.67 (2.39)	30 5/16" (770)	32" (813)	115 1/2" (2934)	53.60 (4.98)	55.76 (5.18)	25.67 (2.39)	88.30 (8.20)		
FWHID/FWHICD811100-3	2 ASA	25.67 (2.39)	30 5/16" (770)	32" (813)	115 1/2" (2934)	53.60 (4.98)	55.76 (5.18)	51.33 (4.77)	88.30 (8.20)		
FWHID/FWHICD96100-3	1 ASS/SAS/SSA/ASA	27.27 (2.53)	32 5/16" (821)	34" (864)	115 1/2" (2934)	57.91 (5.38)	60.24 (5.60)	27.27 (2.53)	93.28 (8.67)		
FWHID/FWHICD96100-3	2 ASA	27.27 (2.53)	32 5/16" (821)	34" (864)	115 1/2" (2934)	57.91 (5.38)	60.24 (5.60)	54.54 (5.07)	93.28 (8.67)		

* Dimensions in parentheses are in millimeters or square meters.
 ** For two-panel AP/PA doors with only one panel open, clear opening is based on the active panel open and the passive panel closed.
 *** Active left- and right-hinged patio doors also available. Contact your Andersen supplier for more information.

HINGED INSWING PATIO DOORS

Grille Patterns

	Queen Anne	Diamond	Prairie A	Colonial	Modified Colonial	Modified Colonial with Simulated Check Rail	Tall Fractional	Tall Fractional with Simulated Check Rail	Short Fractional	Short Fractional with Simulated Check Rail
Hinged Inswing Patio Doors Traditional Panels										
Hinged Inswing Patio Doors Contemporary Panels										

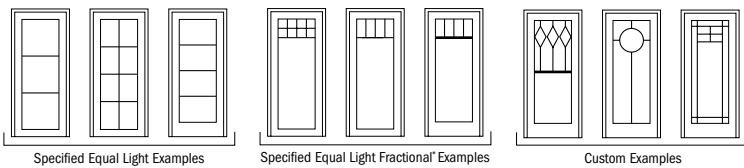

Number of lights and overall pattern varies with patio door size. Patterns may not be available in all configuration or sizes.

Specified equal light, specified equal light fractional and custom patterns are also available. For more grille options, see page 19 or visit andersenwindows.com/grilles.

*Bottom horizontal bar located at center or at custom dimensions.

Drop-Nose Channel

Optional drop-nose channel is available when higher product performance is required. Wood and concrete installations shown.

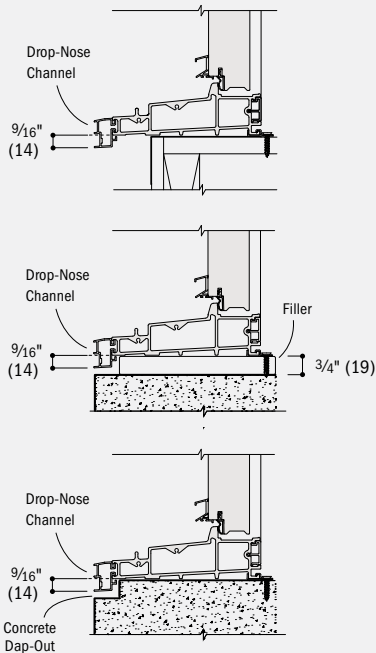

Remodeler Sill Bracket

Optional remodeler sill bracket is available for installation with an existing finished interior floor.

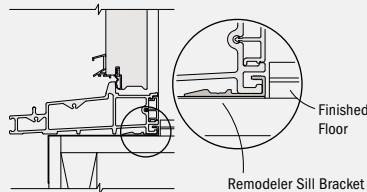

Hinged Inswing Patio Door Details – 6 9/16" (167) Base Jamb Depth with Traditional Panels

Scale 1 1/2" (38) = 1'-0" (305) – 1:8

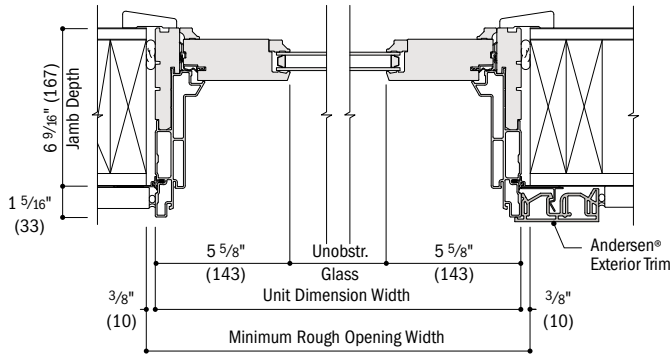

Horizontal Section
Stationary (S), Traditional Panel

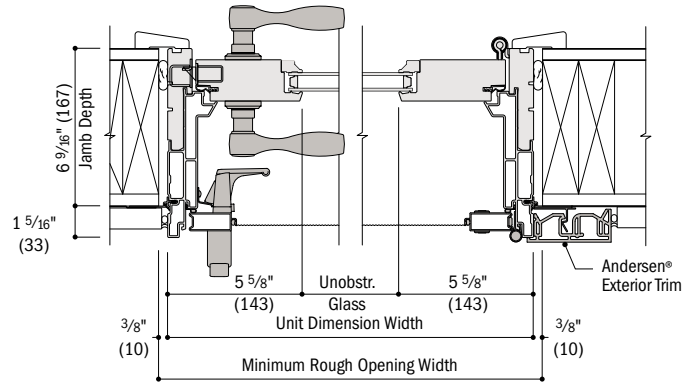

Horizontal Section
Active (AR/AL), Traditional Panel, Hinged Insect Screen

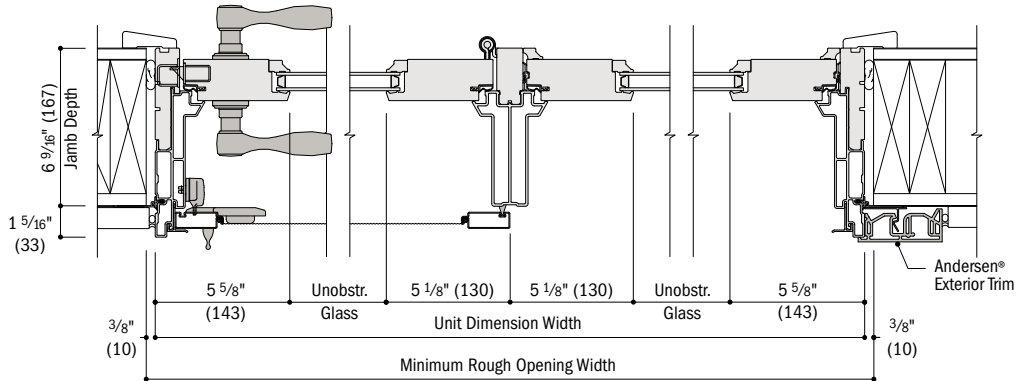

Horizontal Section
Two-Panel Active-Stationary (ASR/ASL/SAL/SAR), Traditional Panels, Top-Hung Gliding or Gliding Insect Screen

continued on next page

- 6 9/16" (167) base jamb depth measurement is from back side of installation flange.
- Light-colored areas are parts included with door. Dark-colored areas are additional Andersen® parts required to complete door assembly as shown.
- Dimensions in parentheses are in millimeters.
- **Rough openings may need to be increased to allow for use of building wraps, flashing, sill panning, brackets, fasteners or other items. See installation information on pages 226-227.**
- Details are for illustration only and are not intended to represent product installation methods or materials. Refer to product installation instructions at andersenwindows.com.

HINGED INSWING PATIO DOORS

Hinged Inswing Patio Door Details – 6 9/16" (167) Base Jamb Depth with Traditional Panels *(continued)*

Scale 1 1/2" (38) = 1'-0" (305) – 1:8

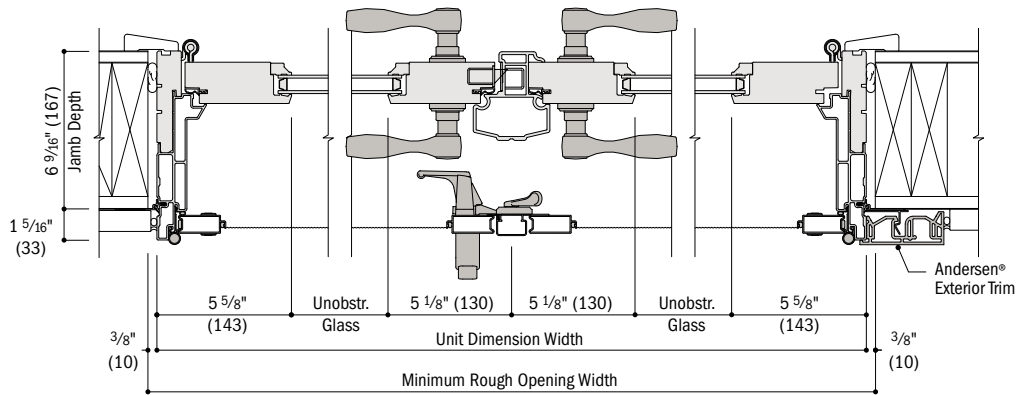

Horizontal Section

Two-Panel Active-Passive (ARLR/PALR), Traditional Panels, Hinged Insect Screen with Astragal

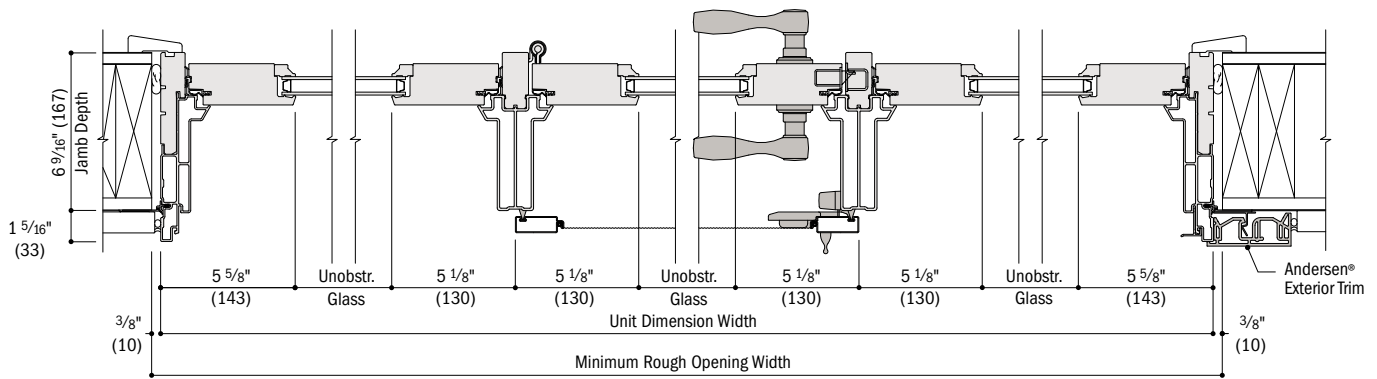

Horizontal Section

Three-Panel Stationary-Active-Stationary (SASL/SASR/ASSL/ASSR/SSAL/SSAR),
Traditional Panels, Top-Hung Gliding or Gliding Insect Screen

continued on next page

- 6 9/16" (167) base jamb depth measurement is from back side of installation flange.
- Light-colored areas are parts included with door. Dark-colored areas are additional Andersen® parts required to complete door assembly as shown.
- Dimensions in parentheses are in millimeters.
- **Rough openings may need to be increased to allow for use of building wraps, flashing, sill panning, brackets, fasteners or other items. See installation information on pages 226-227.**
- Details are for illustration only and are not intended to represent product installation methods or materials. Refer to product installation instructions at andersenwindows.com.

Hinged Inswing Patio Door Details – 6 9/16" (167) Base Jamb Depth with Traditional Panels *(continued)*

Scale 1 1/2" (38) = 1'-0" (305) – 1:8

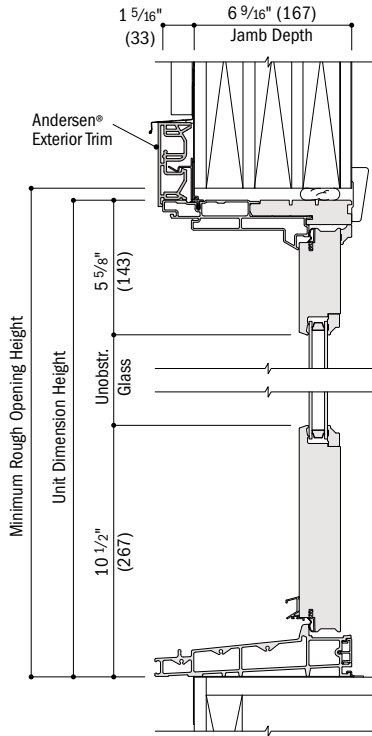

Vertical Section
Stationary, Traditional Panel

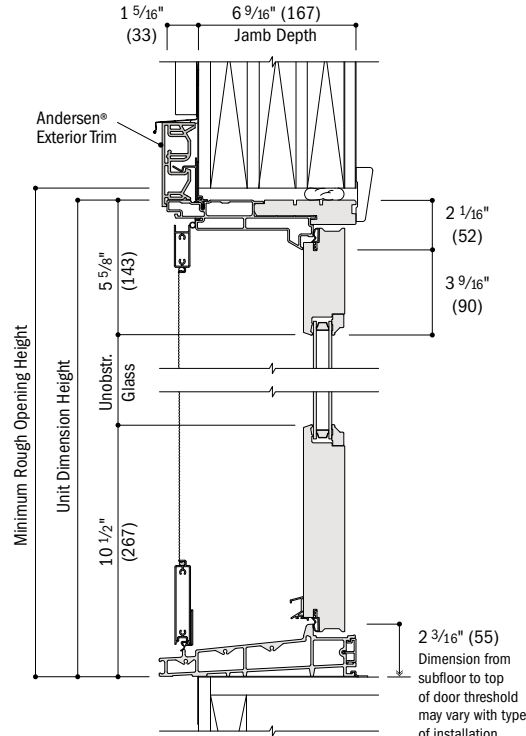

Vertical Section
Active, Traditional Panel, Hinged Insect Screen

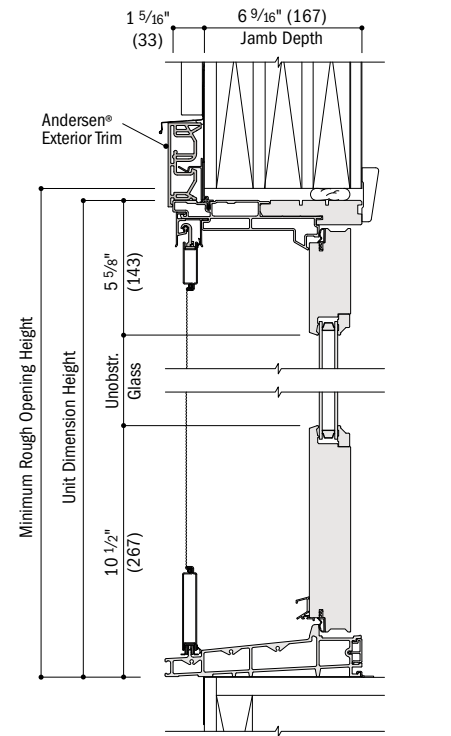

Vertical Section
Active, Traditional Panel, Top-Hung Gliding Insect Screen

For optional drop-nose channel and remodeler sill bracket details, see page 140.

See pages 168-171 for joining details.

- 6 9/16" (167) base jamb depth measurement is from back side of installation flange.
- Light-colored areas are parts included with door. Dark-colored areas are additional Andersen® parts required to complete door assembly as shown.
- Dimensions in parentheses are in millimeters.
- **Rough openings may need to be increased to allow for use of building wraps, flashing, sill panning, brackets, fasteners or other items. See installation information on pages 226-227.**
- Details are for illustration only and are not intended to represent product installation methods or materials. Refer to product installation instructions at andersenwindows.com.

HINGED INSWING PATIO DOORS

Hinged Inswing Patio Door Details – 4 9/16" (116) Base Jamb Depth with Traditional Panels

Scale 1 1/2" (38) = 1'-0" (305) – 1:8

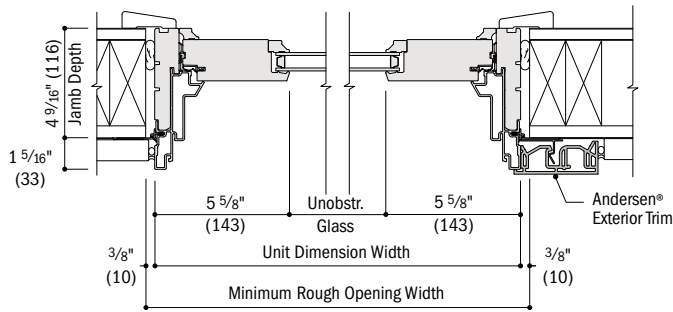

Horizontal Section
Stationary (S), Traditional Panel

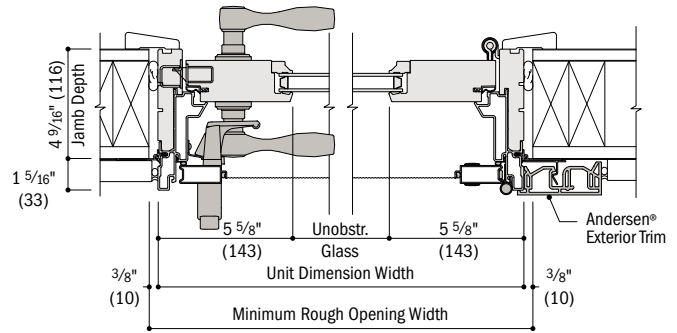

Horizontal Section
Active (AR/AL), Traditional Panel, Hinged Insect Screen

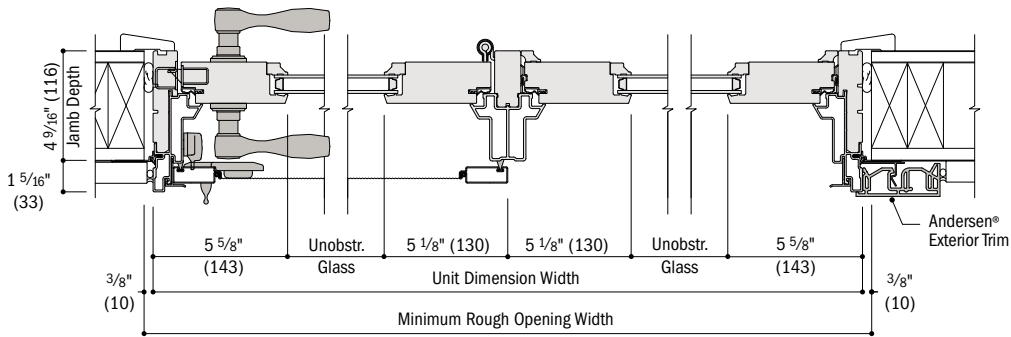

Horizontal Section
Two-Panel Active-Stationary (ASR/ASL/SAL/SAR), Traditional Panels, Top-Hung Gliding or Gliding Insect Screen

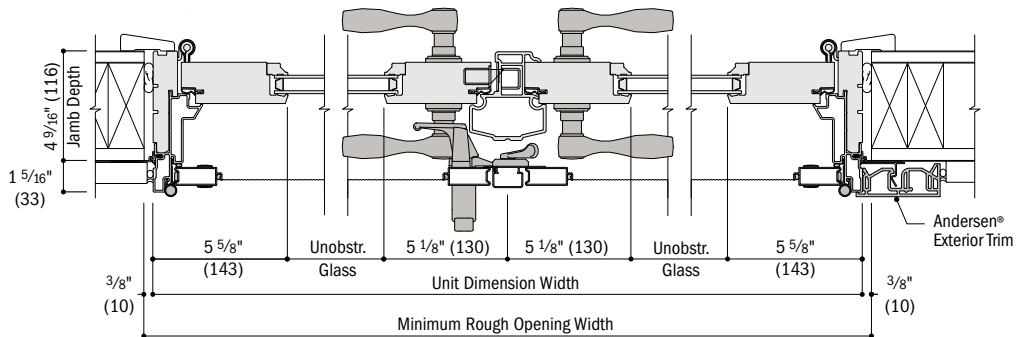

Horizontal Section
Two-Panel Active-Passive (APLR/PALR), Traditional Panels, Hinged Insect Screen

continued on next page

- 4 9/16" (116) base jamb depth measurement is from back side of installation flange.
- Light-colored areas are parts included with door. Dark-colored areas are additional Andersen® parts required to complete door assembly as shown.
- Dimensions in parentheses are in millimeters.
- **Rough openings may need to be increased to allow for use of building wraps, flashing, sill panning, brackets, fasteners or other items. See installation information on pages 226-227.**
- Details are for illustration only and are not intended to represent product installation methods or materials. Refer to product installation instructions at andersenwindows.com.

Hinged Inswing Patio Door Details - 4 9/16" (116) Base Jamb Depth with Traditional Panels *(continued)*

Scale 1 1/2" (38) = 1'-0" (305) - 1:8

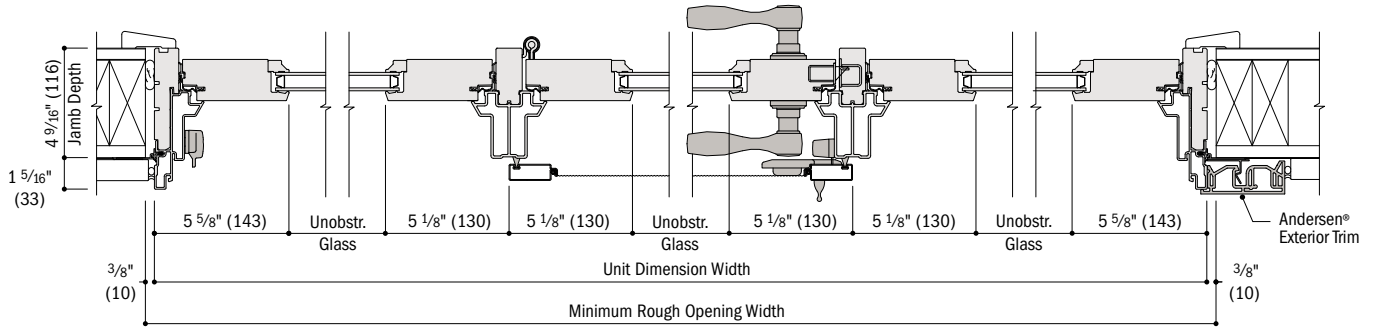

Horizontal Section

Three-Panel Stationary-Active-Stationary (SASL/SASR/ASL/ASSR/SSAL/SSAR),
Traditional Panels, Top-Hung Gliding or Gliding Insect Screen

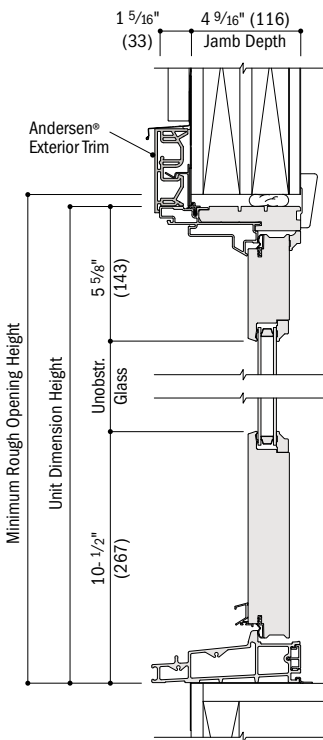

Vertical Section
Stationary, Traditional Panel

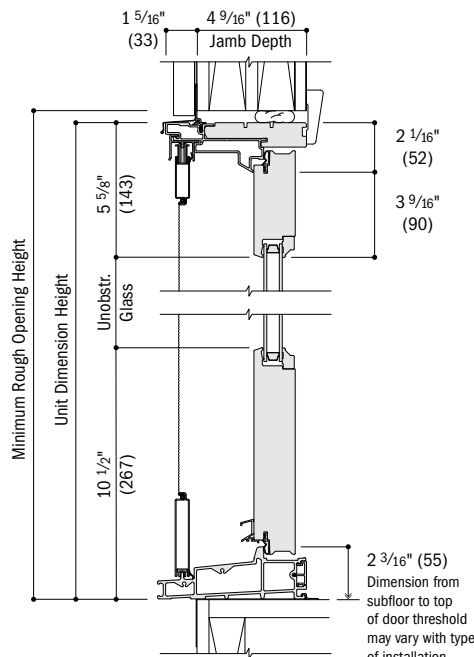

Vertical Section
Active, Traditional Panel, Gliding Insect Screen

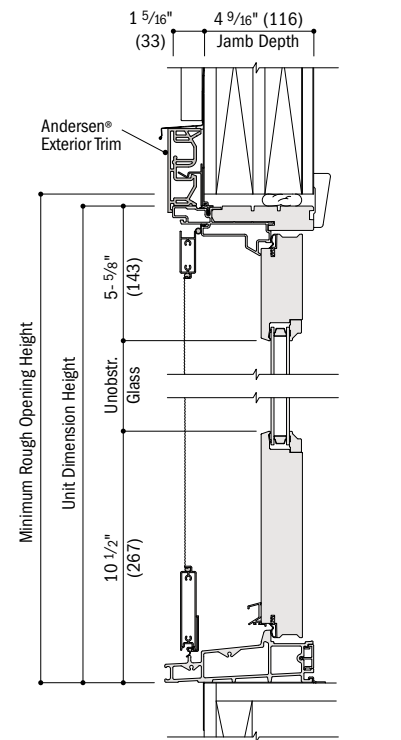

Vertical Section
Active, Traditional Panel, Hinged Insect Screen

For optional drop-nose channel and remodeler sill bracket details, see page 140.

See pages 168-171 for joining details.

- 4 9/16" (116) base jamb depth measurement is from back side of installation flange.
- Light-colored areas are parts included with door. Dark-colored areas are additional Andersen® parts required to complete door assembly as shown.
- Dimensions in parentheses are in millimeters.
- Rough openings may need to be increased to allow for use of building wraps, flashing, sill panning, brackets, fasteners or other items. See installation information on pages 226-227.
- Details are for illustration only and are not intended to represent product installation methods or materials. Refer to product installation instructions at andersenwindows.com.

A-Series Hinged
Inswing Patio Doors

HINGED INSWING PATIO DOORS

Hinged Inswing Patio Door Details – 6 9/16" (167) Base Jamb Depth with Contemporary Panels

Scale 1 1/2" (38) = 1'-0" (305) – 1:8

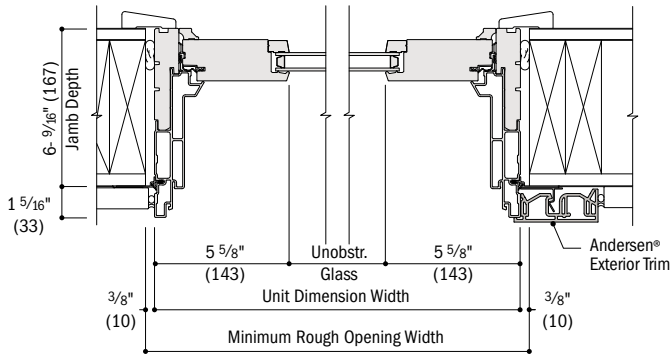

Horizontal Section
Stationary (S), Contemporary Panel

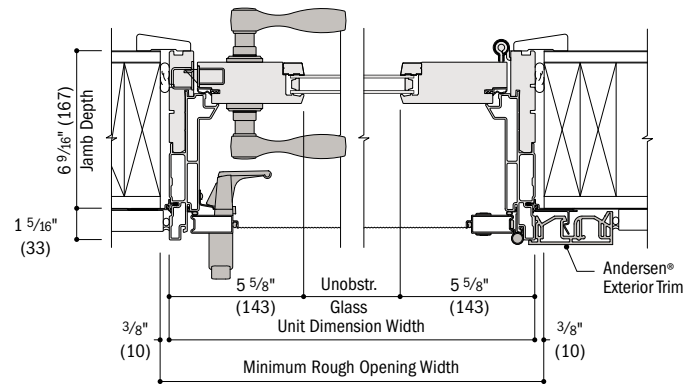

Horizontal Section
Active (AR/AL), Contemporary Panel, Hinged Insect Screen

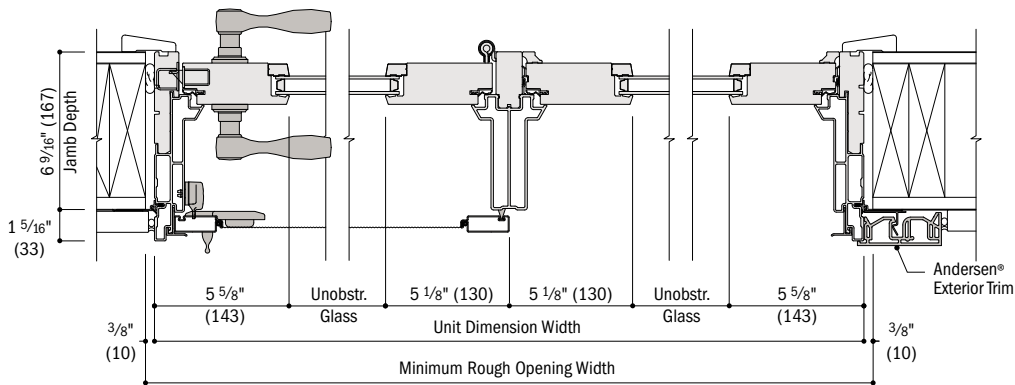

Horizontal Section
Two-Panel Active-Stationary (ASR/ASL/SAL/SAR), Contemporary Panels, Top-Hung Gliding or Gliding Insect Screen

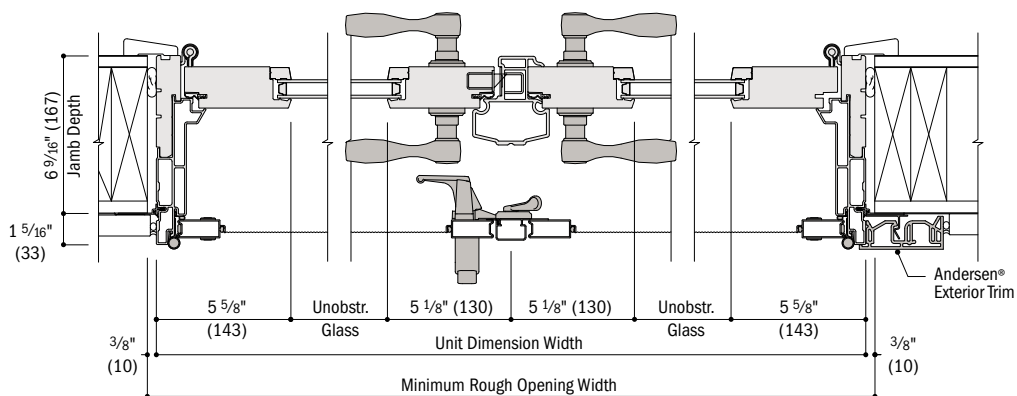

Horizontal Section
Two-Panel Active-Passive (APLR/PALR), Contemporary Panels, Hinged Insect Screen with Astragal

continued on next page

- 6 9/16" (167) base jamb depth measurement is from back side of installation flange.
- Light-colored areas are parts included with door. Dark-colored areas are additional Andersen® parts required to complete door assembly as shown.
- Dimensions in parentheses are in millimeters.
- **Rough openings may need to be increased to allow for use of building wraps, flashing, sill panning, brackets, fasteners or other items. See installation information on pages 226-227.**
- Details are for illustration only and are not intended to represent product installation methods or materials. Refer to product installation instructions at andersenwindows.com.

Hinged Inswing Patio Door Details - 6 9/16" (167) Base Jamb Depth with Contemporary Panels (continued)

Scale 1 1/2" (38) = 1'-0" (305) - 1:8

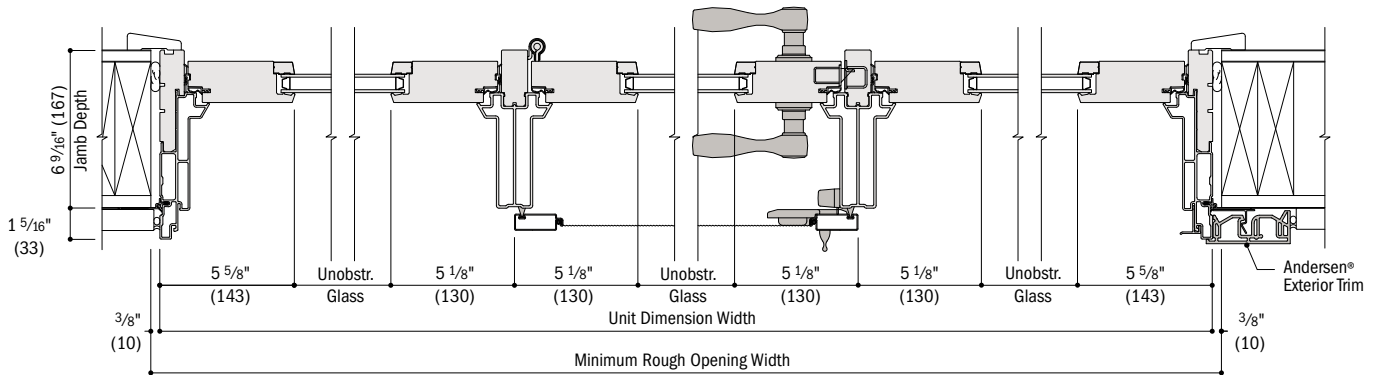

Horizontal Section

Three-Panel Stationary-Active-Stationary (SASL/SASR/ASSL/ASSR/SSAL/SSAR),
Contemporary Panels, Top-Hung Gliding or Gliding Insect Screen

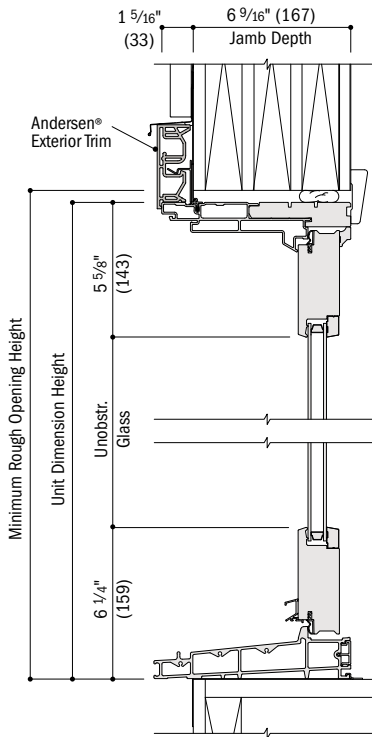

Vertical Section
Stationary, Contemporary Panel

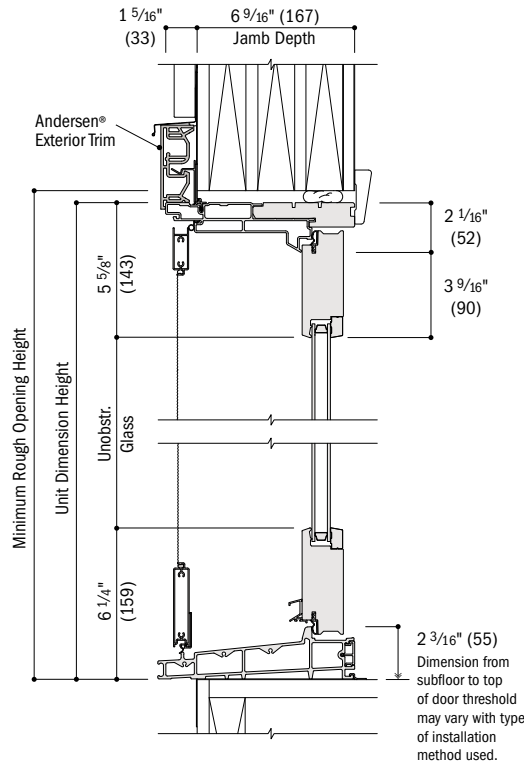

Vertical Section
Active, Contemporary Panel, Hinged Insect Screen

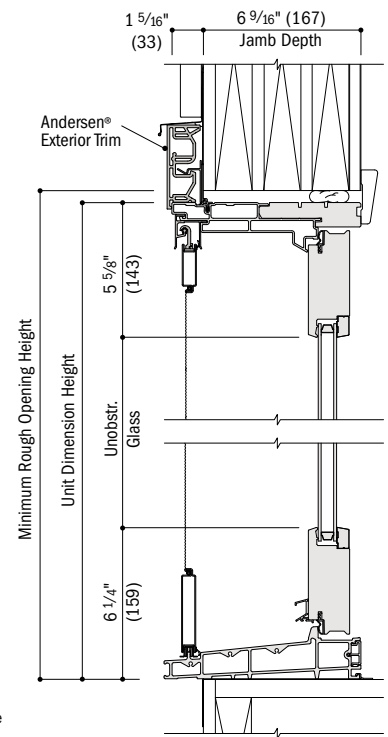

Vertical Section
Active, Contemporary Panel, Top-Hung Gliding Insect Screen

For optional drop-nose channel and remodeler sill bracket details, see page 140.

See pages 168-171 for joining details.

- 6 9/16" (167) base jamb depth measurement is from back side of installation flange.
- Light-colored areas are parts included with door. Dark-colored areas are additional Andersen® parts required to complete door assembly as shown.
- Dimensions in parentheses are in millimeters.
- Rough openings may need to be increased to allow for use of building wraps, flashing, sill panning, brackets, fasteners or other items. See installation information on pages 226-227.
- Details are for illustration only and are not intended to represent product installation methods or materials. Refer to product installation instructions at andersenwindows.com.

HINGED INSWING PATIO DOORS

Hinged Inswing Patio Door Details – 4 9/16" (116) Base Jamb Depth with Contemporary Panels

Scale 1 1/2" (38) = 1'-0" (305) – 1:8

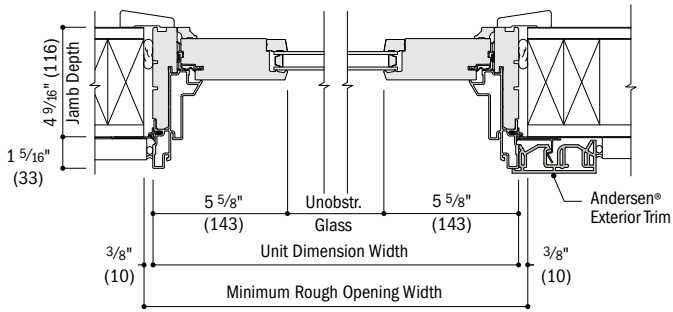

Horizontal Section
Stationary (S), Contemporary Panel

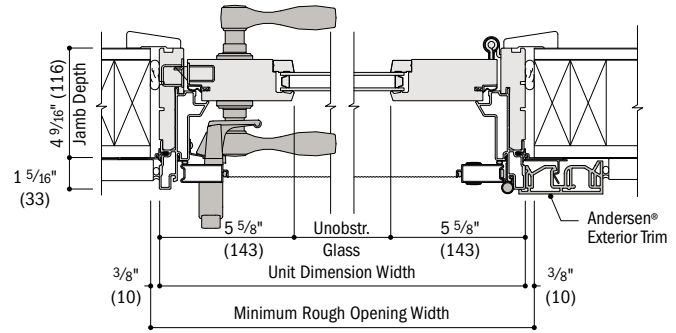

Horizontal Section
Active (AR/AL), Contemporary Panel, Hinged Insect Screen

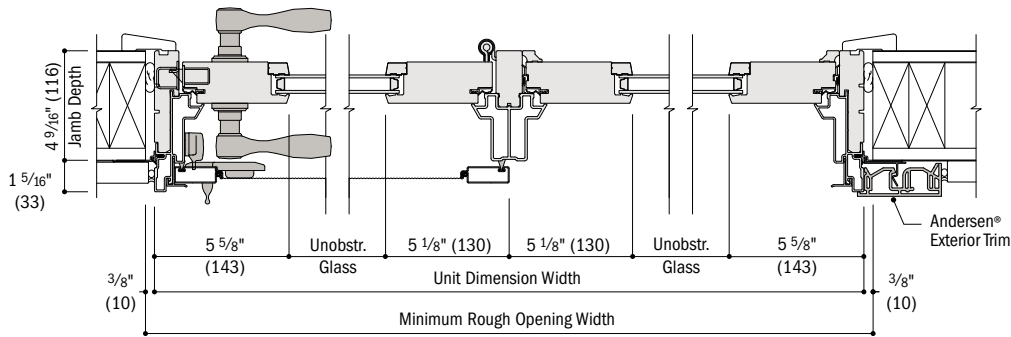

Horizontal Section
Two-Panel Active-Stationary (ASR/ASL/SAL/SAR), Contemporary Panels, Top-Hung Gliding or Gliding Insect Screen

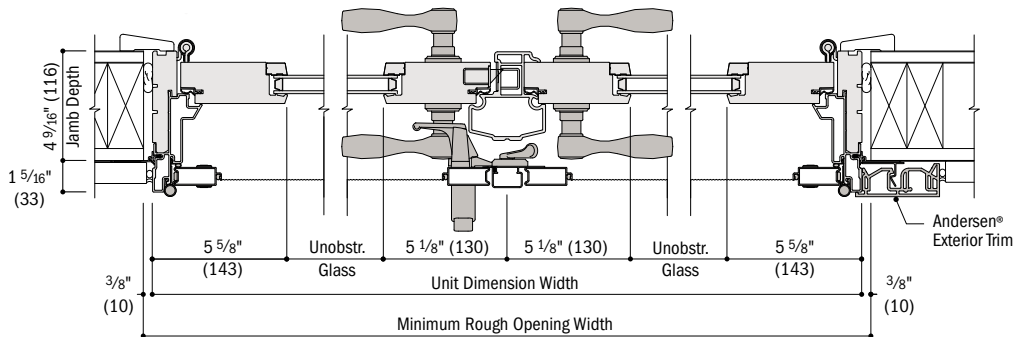

Horizontal Section – Two-Panel Active-Passive (APLR/PALR)
Two-Panel Active-Passive (APLR/PALR), Contemporary Panels, Hinged Insect Screen

continued on next page

- 4 9/16" (116) base jamb depth measurement is from back side of installation flange.
- Light-colored areas are parts included with door. Dark-colored areas are additional Andersen® parts required to complete door assembly as shown.
- Dimensions in parentheses are in millimeters.
- **Rough openings may need to be increased to allow for use of building wraps, flashing, sill panning, brackets, fasteners or other items. See installation information on pages 226-227.**
- Details are for illustration only and are not intended to represent product installation methods or materials. Refer to product installation instructions at andersenwindows.com.

Hinged Inswing Patio Door Details – 4 9/16" (116) Base Jamb Depth with Contemporary Panels (continued)

Scale 1 1/2" (38) = 1'-0" (305) – 1:8

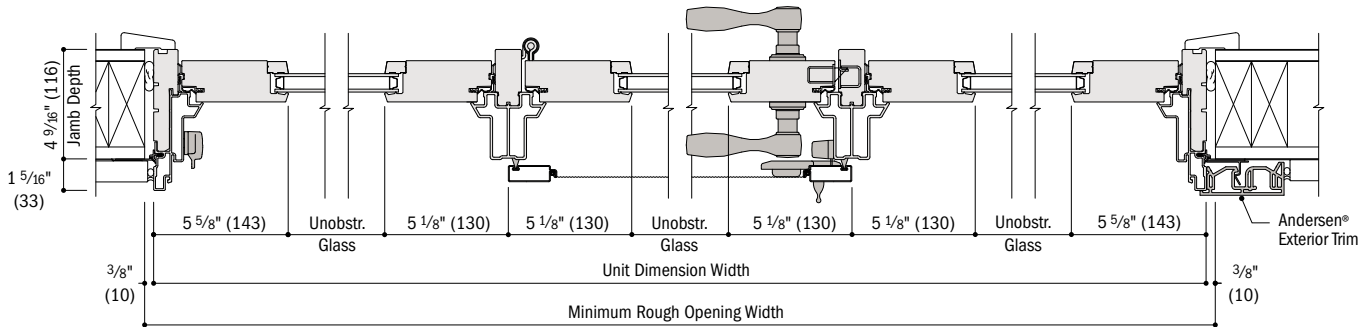

Horizontal Section

Three-Panel Stationary-Active-Stationary (SASL/SASR/ASL/ASSR/SSAL/SSAR), Contemporary Panels, Top-Hung Gliding or Gliding Insect Screen

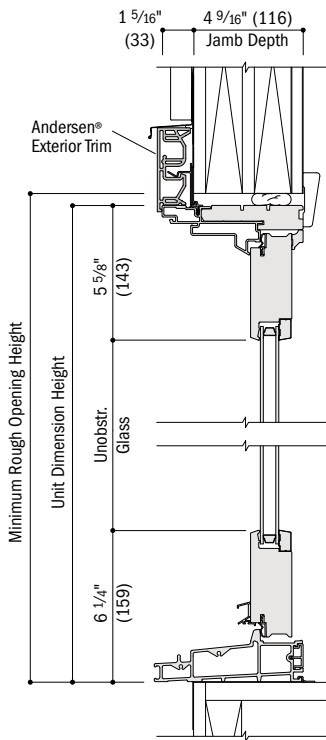

Vertical Section
Stationary, Contemporary Panel

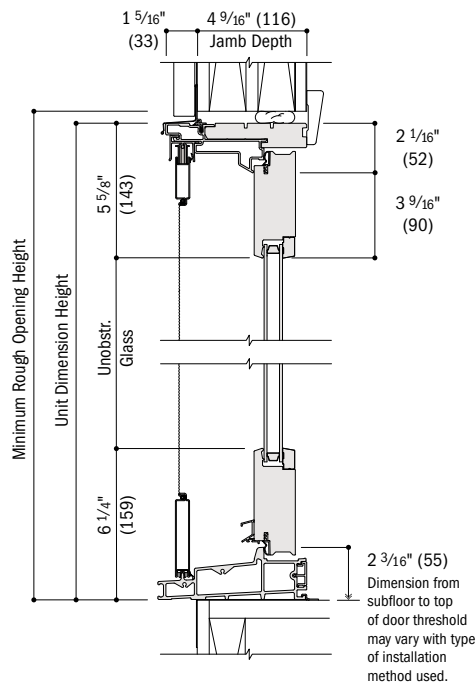

Vertical Section
Active, Contemporary Panel, Gliding Insect Screen

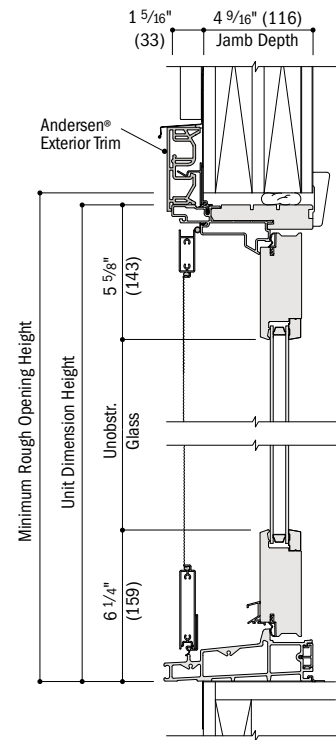

Vertical Section
Active, Contemporary Panel, Hinged Insect Screen

For optional drop-nose channel and remodeler sill bracket details, see page 140.

See pages 168-171 for joining details.

- 4 9/16" (116) base jamb depth measurement is from back side of installation flange.
- Light-colored areas are parts included with door. Dark-colored areas are additional Andersen® parts required to complete door assembly as shown.
- Dimensions in parentheses are in millimeters.
- Rough openings may need to be increased to allow for use of building wraps, flashing, sill panning, brackets, fasteners or other items. See installation information on pages 226-227.
- Details are for illustration only and are not intended to represent product installation methods or materials. Refer to product installation instructions at andersenwindows.com.

HINGED OUTSWING PATIO DOORS

Table of Hinged Outswing Patio Door Sizes

Scale 1/8" (3) = 1'-0" (305) – 1:96

Door Dimension	2'-0 1/8"	2'-0 1/8"	2'-0 1/8"	3'-11 1/4"	2'-6 1/8"	2'-6 1/8"	2'-6 1/8"	4'-11 1/4"
	(612)	(612)	(612)	(1200)	(764)	(764)	(764)	(1505)
Minimum Rough Opening	2'-1"	2'-1"	2'-1"	4'-0"	2'-7"	2'-7"	2'-7"	5'-0"
	(634)	(634)	(634)	(1219)	(787)	(787)	(787)	(1524)
Unobstructed Glass (single panel only)	12 7/8"	12 7/8"	12 7/8"	12 7/8"	18 7/8"	18 7/8"	18 7/8"	18 7/8"
	(327)	(327)	(327)	(327)	(479)	(479)	(479)	(479)

Door Dimension	2'-8 1/8"	2'-8 1/8"	2'-8 1/8"	5'-3 1/4"	3'-0 1/8"	3'-0 1/8"	3'-0 1/8"	5'-11 1/4"
	(815)	(815)	(815)	(1607)	(917)	(917)	(917)	(1810)
Minimum Rough Opening	2'-9"	2'-9"	2'-9"	5'-4"	3'-1"	3'-1"	3'-1"	6'-0"
	(838)	(838)	(838)	(1626)	(940)	(940)	(940)	(1829)
Unobstructed Glass (single panel only)	20 7/8"	20 7/8"	20 7/8"	20 7/8"	24 7/8"	24 7/8"	24 7/8"	24 7/8"
	(530)	(530)	(530)	(530)	(632)	(632)	(632)	(632)

Door Dimension	3'-2 1/8"	3'-2 1/8"	3'-2 1/8"	6'-3 1/4"
	(968)	(968)	(968)	(1911)
Minimum Rough Opening	3'-3"	3'-3"	3'-3"	6'-4"
	(991)	(991)	(991)	(1930)
Unobstructed Glass (single panel only)	26 7/8"	26 7/8"	26 7/8"	26 7/8"
	(683)	(683)	(683)	(683)



Custom-size patio doors are available in 1/8" (3) increments.
See pages 173 and 175 for custom sizes, specifications and information on shipping patio doors greater than 8' (2438).

Choose traditional (**FWOD**) or contemporary (**FWOCD**) panel. Contemporary panels shown. Stationary (**S**) patio doors can be used as an individual patio door or a sidelight.

Grille patterns shown on page 151. Details shown on pages 153-155.

- 1 FWOD/FWODD
- 2 FWOD/FWODD
- 3 FWOD/FWODD
- 4 FWOD/FWODD

- 1 FWOD/FWODD
- 2 FWOD/FWODD
- 3 FWOD/FWODD
- 4 FWOD/FWODD

- 1 FWOD/FWODD
- 2 FWOD/FWODD
- 3 FWOD/FWODD
- 4 FWOD/FWODD

* "Door Dimension" always refers to outside frame-to-frame dimension.
** "Minimum Rough Opening" dimensions may need to be increased to allow for use of building wraps, flashing, sill panning, brackets, fasteners or other items. See pages 226-227 for more details.
* Dimensions in parentheses are in millimeters.

Identification and Order Designation Description

Viewed from the exterior. Traditional panels shown.

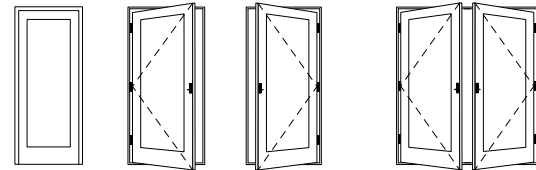

Stationary (non-operating panel) **Left Hinged** (hinges on left) **Right Hinged** (hinges on right) **Active Panel** (operating panel used most often) **Passive Panel** (operating panel with attached astragal)

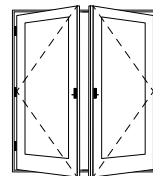

FWOD
FWOCD

Hinged Outswing Patio Door with Traditional (**FWOD**) or Contemporary (**FWOCD**) Panels

6068 A P L R

Active Panel (panel used most often) Left Hinged Right Hinged

Door Rough Opening Passive Panel

Four Patio Door Heights

Traditional Panels

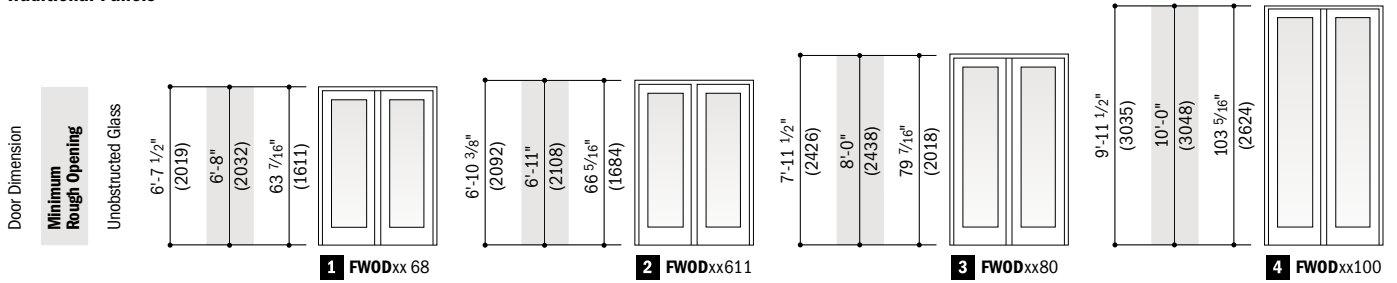

Contemporary Panels

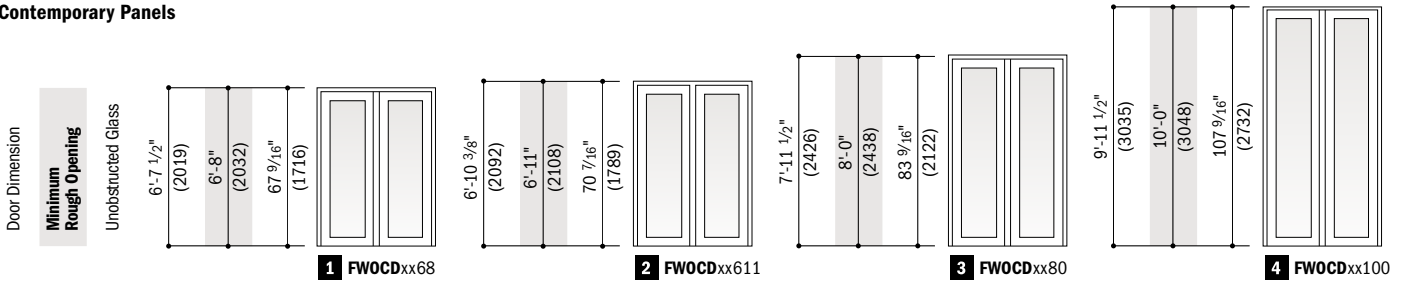

Grille Patterns

	Queen Anne	Diamond	Prairie A	Colonial	Modified Colonial	Modified Colonial SCR Simulated Check Rail	Tall Fractional	Tall Fractional SCR Simulated Check Rail	Short Fractional	Short Fractional SCR Simulated Check Rail
Hinged Outswing Patio Doors Traditional Panels										
Hinged Outswing Patio Doors Contemporary Panels										

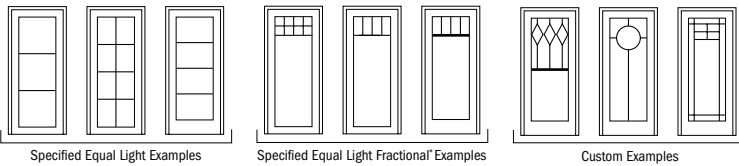

Number of lights and overall pattern varies with patio door size. Patterns may not be available in all configuration or sizes. Specified equal light, specified equal light fractional and custom patterns are also available. For more grille options, see page 19 or visit andersenwindows.com/grilles.

*Bottom horizontal bar located at center or at custom dimensions.

HINGED OUTSWING PATIO DOORS

Hinged Outswing Patio Door Opening and Area Specifications

Door Number	Number of Panels in Open Position*	Clear Opening Maximums				Traditional Panel Glass Area Sq. Ft./ (m ²)	Contemporary Panel Glass Area Sq. Ft./ (m ²)	Vent Sq. Ft./ (m ²)	Overall Door Area Sq. Ft./ (m ²)
		Clear Opening Sq. Ft./ (m ²)	90° Width Inches/(mm)	Full Width Inches/(mm)	Height Inches/(mm)				
FWOD/FW OCD2168	1	10.94 (1.02)	19 1/16" (484)	20 3/4" (527)	76 1/8" (1934)	5.67 (0.53)	6.04 (0.56)	10.94 (1.02)	13.30 (1.24)
FWOD/FW OCD2768	1	14.11 (1.31)	25 1/16" (637)	26 3/4" (679)	76 1/8" (1934)	8.31 (0.77)	8.86 (0.82)	14.11 (1.31)	16.61 (1.54)
FWOD/FW OCD2968	1	15.17 (1.41)	27 1/16" (687)	28 3/4" (730)	76 1/8" (1934)	9.20 (0.85)	9.80 (0.91)	15.17 (1.41)	17.72 (1.65)
FWOD/FW OCD3168	1	17.28 (1.61)	31 1/16" (789)	32 3/4" (832)	76 1/8" (1934)	10.96 (1.02)	11.68 (1.09)	17.28 (1.61)	19.93 (1.85)
FWOD/FW OCD3368	1	18.34 (1.70)	33 1/16" (840)	34 3/4" (883)	76 1/8" (1934)	11.84 (1.10)	12.61 (1.17)	18.34 (1.70)	21.03 (1.95)
FWOD/FW OCD4068	2	23.18 (2.15)	40 5/8" (1032)	43 7/8" (1114)	76 1/8" (1934)	11.34 (1.05)	12.09 (1.12)	23.18 (2.15)	26.09 (2.42)
FWOD/FW OCD4068	1	10.89 (1.01)	19" (483)	20 5/8" (524)	76 1/8" (1934)	11.34 (1.05)	12.09 (1.12)	10.89 (1.01)	26.09 (2.42)
FWOD/FW OCD5068	2	29.52 (2.74)	52 5/8" (1337)	55 7/8" (1419)	76 1/8" (1934)	16.63 (1.54)	17.72 (1.65)	29.52 (2.74)	32.71 (3.04)
FWOD/FW OCD5068	1	14.07 (1.31)	25" (635)	26 5/8" (676)	76 1/8" (1934)	16.63 (1.54)	17.72 (1.65)	14.07 (1.31)	32.71 (3.04)
FWOD/FW OCD5468	2	31.63 (2.94)	56 5/8" (1438)	59 7/8" (1521)	76 1/8" (1934)	18.39 (1.71)	19.60 (1.82)	31.63 (2.94)	34.92 (3.24)
FWOD/FW OCD5468	1	15.12 (1.40)	27" (686)	28 5/8" (727)	76 1/8" (1934)	18.39 (1.71)	19.60 (1.82)	15.12 (1.40)	34.92 (3.24)
FWOD/FW OCD6068	2	35.86 (3.33)	64 5/8" (1641)	67 7/8" (1724)	76 1/8" (1934)	21.92 (2.04)	23.35 (2.17)	35.86 (3.33)	39.34 (3.65)
FWOD/FW OCD6068	1	17.24 (1.60)	31" (787)	32 5/8" (829)	76 1/8" (1934)	21.92 (2.04)	23.35 (2.17)	17.24 (1.60)	39.34 (3.65)
FWOD/FW OCD6468	2	37.97 (3.53)	68 5/8" (1743)	71 7/8" (1826)	76 1/8" (1934)	23.68 (2.20)	25.23 (2.34)	37.97 (3.53)	41.54 (3.86)
FWOD/FW OCD6468	1	18.29 (1.70)	33" (838)	34 5/8" (879)	76 1/8" (1934)	23.68 (2.20)	25.23 (2.34)	18.29 (1.70)	41.54 (3.86)
FWOD/FW OCD21611	1	11.35 (1.05)	19 1/16" (484)	20 3/4" (527)	79" (2007)	5.93 (0.55)	6.30 (0.59)	11.35 (1.05)	13.78 (1.28)
FWOD/FW OCD27611	1	14.64 (1.36)	25 1/16" (637)	26 3/4" (679)	79" (2007)	8.69 (0.81)	9.24 (0.86)	14.64 (1.36)	17.22 (1.60)
FWOD/FW OCD29611	1	15.74 (1.46)	27 1/16" (687)	28 3/4" (730)	79" (2007)	9.61 (0.89)	10.21 (0.95)	15.74 (1.46)	18.36 (1.71)
FWOD/FW OCD31611	1	17.93 (1.67)	31 1/16" (789)	32 3/4" (832)	79" (2007)	11.45 (1.06)	12.17 (1.13)	17.93 (1.67)	20.65 (1.92)
FWOD/FW OCD33611	1	19.03 (1.77)	33 1/16" (840)	34 3/4" (883)	79" (2007)	12.38 (1.15)	13.15 (1.22)	19.03 (1.77)	21.79 (2.02)
FWOD/FW OCD40611	2	24.05 (2.23)	40 5/8" (1032)	43 7/8" (1114)	79" (2007)	11.86 (1.10)	12.60 (1.17)	24.05 (2.23)	27.03 (2.51)
FWOD/FW OCD40611	1	11.31 (1.05)	19" (483)	20 5/8" (524)	79" (2007)	11.86 (1.10)	12.60 (1.17)	11.31 (1.05)	27.03 (2.51)
FWOD/FW OCD50611	2	30.63 (2.85)	52 5/8" (1337)	55 7/8" (1419)	79" (2007)	17.38 (1.61)	18.47 (1.72)	30.63 (2.85)	33.89 (3.15)
FWOD/FW OCD50611	1	14.60 (1.36)	25" (635)	26 5/8" (676)	79" (2007)	17.38 (1.61)	18.47 (1.72)	14.60 (1.36)	33.89 (3.15)
FWOD/FW OCD54611	2	32.83 (3.05)	56 5/8" (1438)	59 7/8" (1521)	79" (2007)	19.22 (1.79)	20.43 (1.90)	32.83 (3.05)	36.18 (3.36)
FWOD/FW OCD54611	1	15.69 (1.46)	27" (686)	28 5/8" (727)	79" (2007)	19.22 (1.79)	20.43 (1.90)	15.69 (1.46)	36.18 (3.36)
FWOD/FW OCD60611	2	37.21 (3.46)	64 5/8" (1641)	67 7/8" (1724)	79" (2007)	22.91 (2.13)	24.34 (2.26)	37.21 (3.46)	40.76 (3.79)
FWOD/FW OCD60611	1	17.89 (1.66)	31" (787)	32 5/8" (829)	79" (2007)	22.91 (2.13)	24.34 (2.26)	17.89 (1.66)	40.76 (3.79)
FWOD/FW OCD64611	2	39.41 (3.66)	68 5/8" (1743)	71 7/8" (1826)	79" (2007)	24.75 (2.30)	26.30 (2.44)	39.41 (3.66)	43.05 (4.00)
FWOD/FW OCD64611	1	18.98 (1.76)	33" (838)	34 5/8" (879)	79" (2007)	24.75 (2.30)	26.30 (2.44)	18.98 (1.76)	43.05 (4.00)
FWOD/FW OCD2180	1	13.24 (1.23)	19 1/16" (484)	20 3/4" (527)	92 1/8" (2340)	7.10 (0.66)	7.47 (0.69)	13.24 (1.23)	15.98 (1.48)
FWOD/FW OCD2780	1	17.07 (1.59)	25 1/16" (637)	26 3/4" (679)	92 1/8" (2340)	10.41 (0.97)	10.96 (1.02)	17.07 (1.59)	19.96 (1.85)
FWOD/FW OCD2980	1	18.35 (1.71)	27 1/16" (687)	28 3/4" (730)	92 1/8" (2340)	11.52 (1.07)	12.12 (1.13)	18.35 (1.71)	21.28 (1.98)
FWOD/FW OCD3180	1	20.91 (1.94)	31 1/16" (789)	32 3/4" (832)	92 1/8" (2340)	13.72 (1.27)	14.44 (1.34)	20.91 (1.94)	23.94 (2.22)
FWOD/FW OCD3380	1	22.19 (2.06)	33 1/16" (840)	34 3/4" (883)	92 1/8" (2340)	14.82 (1.38)	15.60 (1.45)	22.19 (2.06)	25.26 (2.35)
FWOD/FW OCD4080	2	28.05 (2.61)	40 5/8" (1032)	43 7/8" (1114)	92 1/8" (2340)	14.20 (1.32)	14.95 (1.39)	28.05 (2.61)	31.34 (2.91)
FWOD/FW OCD4080	1	13.18 (1.22)	19" (483)	20 5/8" (524)	92 1/8" (2340)	14.20 (1.32)	14.95 (1.39)	13.18 (1.22)	31.34 (2.91)
FWOD/FW OCD5080	2	35.72 (3.32)	52 5/8" (1337)	55 7/8" (1419)	92 1/8" (2340)	20.82 (1.93)	21.91 (2.04)	35.72 (3.32)	39.29 (3.65)
FWOD/FW OCD5080	1	17.02 (1.58)	25" (635)	26 5/8" (676)	92 1/8" (2340)	20.82 (1.93)	21.91 (2.04)	17.02 (1.58)	39.29 (3.65)
FWOD/FW OCD5480	2	38.28 (3.56)	56 5/8" (1438)	59 7/8" (1521)	92 1/8" (2340)	23.03 (2.14)	24.23 (2.25)	38.28 (3.56)	41.95 (3.90)
FWOD/FW OCD5480	1	18.30 (1.70)	27" (686)	28 5/8" (727)	92 1/8" (2340)	23.03 (2.14)	24.23 (2.25)	18.30 (1.70)	41.95 (3.90)
FWOD/FW OCD6080	2	43.40 (4.03)	64 5/8" (1641)	67 7/8" (1724)	92 1/8" (2340)	27.44 (2.55)	28.88 (2.68)	43.40 (4.03)	47.25 (4.39)
FWOD/FW OCD6080	1	20.86 (1.94)	31" (787)	32 5/8" (829)	92 1/8" (2340)	27.44 (2.55)	28.88 (2.68)	20.86 (1.94)	47.25 (4.39)
FWOD/FW OCD6480	2	45.96 (4.27)	68 5/8" (1743)	71 7/8" (1826)	92 1/8" (2340)	29.65 (2.75)	31.20 (2.90)	45.96 (4.27)	49.91 (4.64)
FWOD/FW OCD6480	1	22.14 (2.06)	33" (838)	34 5/8" (879)	92 1/8" (2340)	29.65 (2.75)	31.20 (2.90)	22.14 (2.06)	49.91 (4.64)
FWOD/FW OCD21100	1	16.73 (1.55)	19 1/16" (484)	20 3/4" (527)	116 1/8" (2950)	9.25 (0.86)	9.62 (0.89)	16.73 (1.55)	19.99 (1.86)
FWOD/FW OCD27100	1	21.57 (2.00)	25 1/16" (637)	26 3/4" (679)	116 1/8" (2950)	13.56 (1.26)	14.10 (1.31)	21.57 (2.00)	24.97 (2.32)
FWOD/FW OCD29100	1	23.18 (2.15)	27 1/16" (687)	28 3/4" (730)	116 1/8" (2950)	14.99 (1.39)	15.60 (1.45)	23.18 (2.15)	26.63 (2.47)
FWOD/FW OCD31100	1	26.41 (2.45)	31 1/16" (789)	32 3/4" (832)	116 1/8" (2950)	17.87 (1.66)	18.59 (1.73)	26.41 (2.45)	29.95 (2.78)
FWOD/FW OCD33100	1	28.02 (2.60)	33 1/16" (840)	34 3/4" (883)	116 1/8" (2950)	19.30 (1.79)	20.08 (1.87)	28.02 (2.60)	31.61 (2.94)
FWOD/FW OCD40100	2	35.38 (3.29)	40 5/8" (1032)	43 7/8" (1114)	116 1/8" (2950)	18.50 (1.72)	19.24 (1.79)	35.38 (3.29)	39.21 (3.64)
FWOD/FW OCD40100	1	16.63 (1.55)	19" (483)	20 5/8" (524)	116 1/8" (2950)	18.50 (1.72)	19.24 (1.79)	16.63 (1.55)	39.21 (3.64)
FWOD/FW OCD50100	2	45.06 (4.19)	52 5/8" (1337)	55 7/8" (1419)	116 1/8" (2950)	27.11 (2.52)	28.20 (2.62)	45.06 (4.19)	49.17 (4.57)
FWOD/FW OCD50100	1	21.47 (1.99)	25" (635)	26 5/8" (676)	116 1/8" (2950)	27.11 (2.52)	28.20 (2.62)	21.47 (1.99)	49.17 (4.57)
FWOD/FW OCD54100	2	48.28 (4.49)	56 5/8" (1438)	59 7/8" (1521)	116 1/8" (2950)	29.99 (2.79)	31.19 (2.90)	48.28 (4.49)	52.49 (4.88)
FWOD/FW OCD54100	1	23.08 (2.14)	27" (686)	28 5/8" (727)	116 1/8" (2950)	29.99 (2.79)	31.19 (2.90)	23.08 (2.14)	52.49 (4.88)
FWOD/FW OCD60100	2	54.74 (5.09)	64 5/8" (1641)	67 7/8" (1724)	116 1/8" (2950)	35.73 (3.32)	37.17 (3.45)	54.74 (5.09)	59.13 (5.49)
FWOD/FW OCD60100	1	26.31 (2.45)	31" (787)	32 5/8" (829)	116 1/8" (2950)	35.73 (3.32)	37.17 (3.45)	26.31 (2.45)	59.13 (5.49)
FWOD/FW OCD64100	2	57.96 (5.39)	68 5/8" (1743)	71 7/8" (1826)	116 1/8" (2950)	38.61 (3.59)	40.16 (3.73)	57.96 (5.39)	62.45 (5.80)
FWOD/FW OCD64100	1	27.92 (2.59)	33" (838)	34 5/8" (879)	116 1/8" (2950)	38.61 (3.59)	40.16 (3.73)	27.92 (2.59)	62.45 (5.80)

*Dimensions in parentheses are in millimeters or square meters.

*For two-panel doors with only one panel open, clear opening is based on the active panel open and the passive panel closed.

Drop-Nose Channel

Optional drop-nose channel is available when higher product performance is required.
Wood and concrete installations shown.

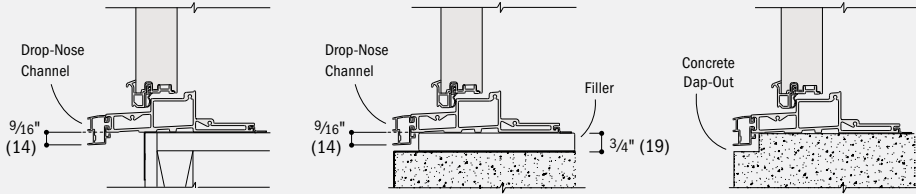

Sill Step

Optional sill step is available in oak or maple.

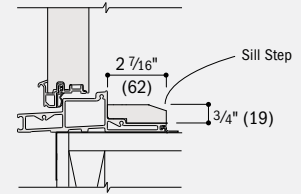

Hinged Outswing Patio Door Details - Traditional Panels

Scale 1 1/2" (38) = 1'-0" (305) – 1:8

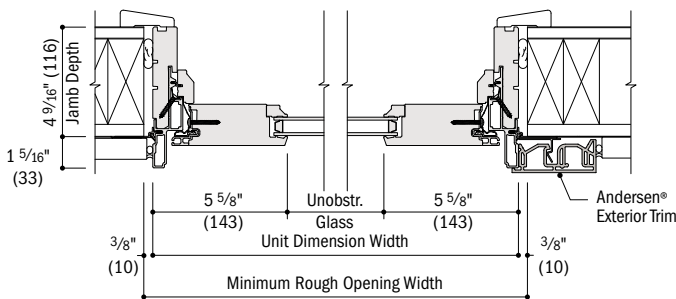

Horizontal Section
Stationary (S), Traditional Panel

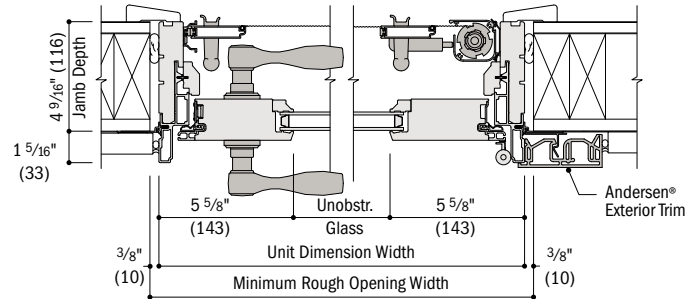

Horizontal Section
Active (AR/AL), Traditional Panel, Retractable Insect Screen

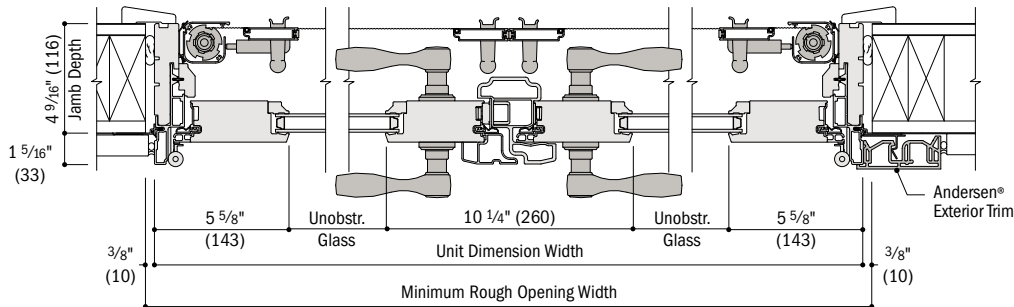

Horizontal Section
Two-Panel Active (APLR/PALR), Traditional Panels, Retractable Insect Screen

continued on next page

- 4 9/16" (116) base jamb depth measurement is from back side of installation flange.
- Light-colored areas are parts included with door. Dark-colored areas are additional Andersen® parts required to complete door assembly as shown.
- Dimensions in parentheses are in millimeters.
- **Minimum rough openings may need to be increased to allow for use of building wraps, flashing, sill panning, brackets, fasteners or other items. See installation information on page 226-227.**
- Details are for illustration only and are not intended to represent product installation methods or materials. Refer to product installation instructions at andersenwindows.com.

HINGED OUTSWING PATIO DOORS

Hinged Outswing Patio Door Details – Traditional Panels *(continued)*

Scale 1 1/2" (38) = 1'-0" (305) – 1:8

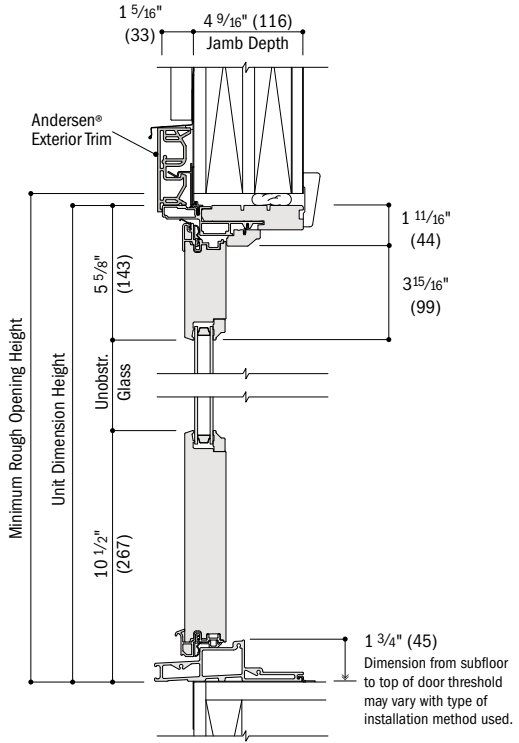

Vertical Section
Stationary, Traditional Panel

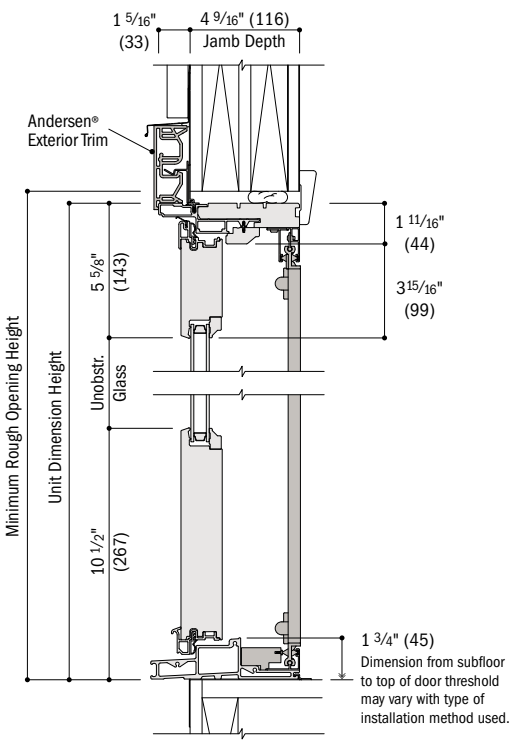

Vertical Section
Active, Traditional Panel, Retractable Insect Screen

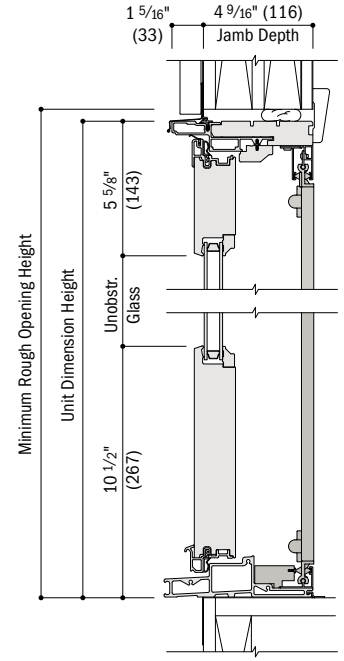

Vertical Section
Active, Traditional Panel, Retractable Insect Screen

For optional drop-nose channel and sill step details, see page 153.

See pages 168-171 for joining details.

Hinged Outswing Patio Door Details – Contemporary Panels

Scale 1 1/2" (38) = 1'-0" (305) – 1:8

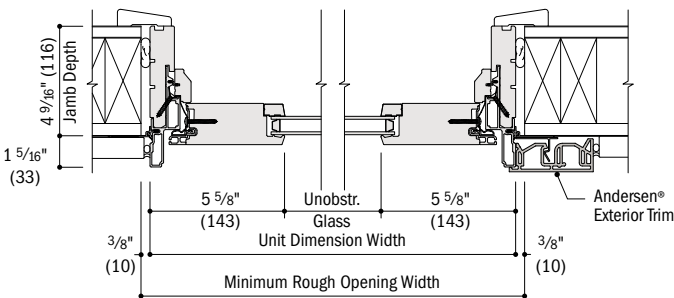

Horizontal Section
Stationary (S), Contemporary Panel

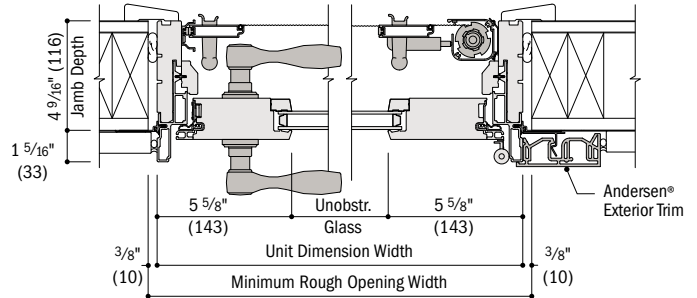

Horizontal Section
Active (AR/AL), Contemporary Panel, Retractable Insect Screen

continued on next page

- 4 9/16" (116) base jamb depth measurement is from back side of installation flange.
- Light-colored areas are parts included with door. Dark-colored areas are additional Andersen® parts required to complete door assembly as shown.
- Dimensions in parentheses are in millimeters.
- **Minimum rough openings may need to be increased to allow for use of building wraps, flashing, sill panning, brackets, fasteners or other items. See installation information on page 226-227.**
- Details are for illustration only and are not intended to represent product installation methods or materials. Refer to product installation instructions at andersenwindows.com.

Hinged Outswing Patio Door Details – Contemporary Panels (continued)

Scale 1 1/2" (38) = 1'-0" (305) – 1:8

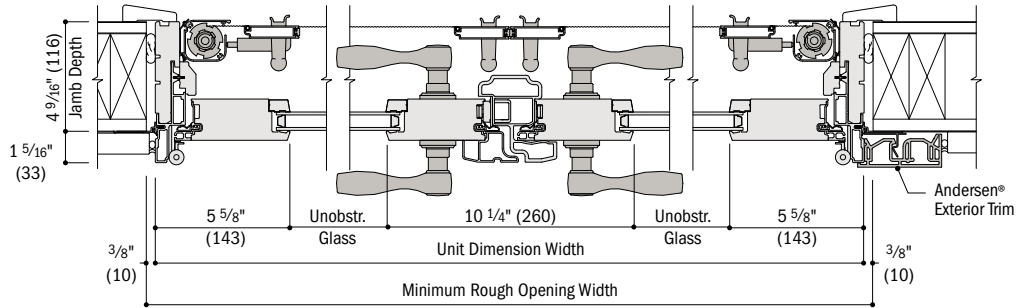

Horizontal Section

Two-Panel Active (APLR/PALR), Contemporary Panels, Retractable Insect Screen

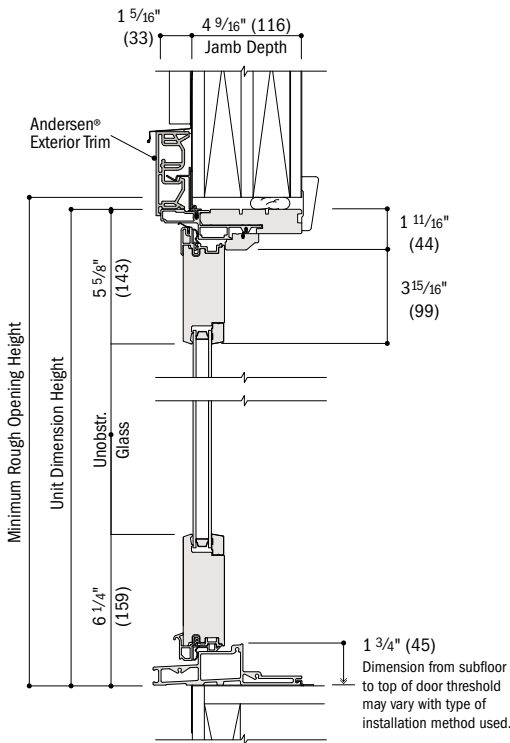

Vertical Section

Stationary, Contemporary Panel

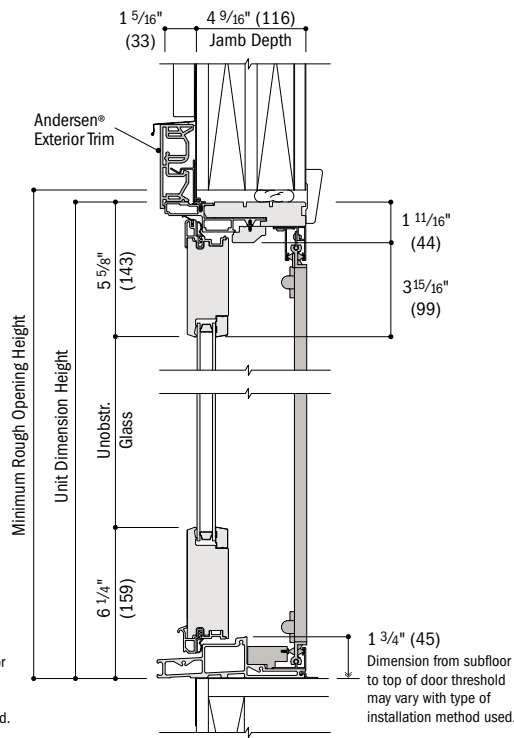

Vertical Section

Active, Contemporary Panel, Retractable Insect Screen

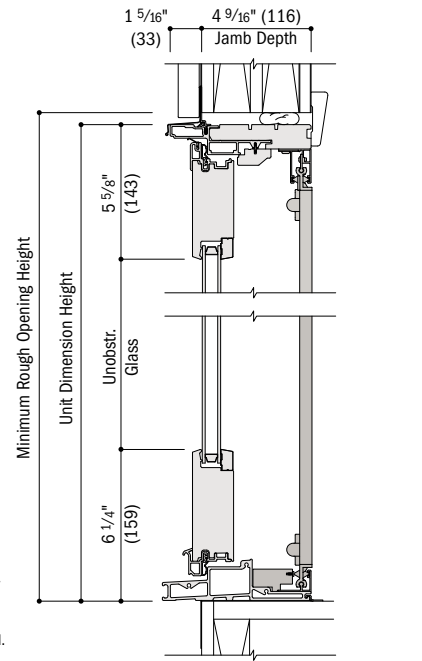

Vertical Section

Active, Contemporary Panel, Retractable Insect Screen

For optional drop-nose channel and sill step details, see page 153.

See pages 168-171 for joining details.

- 4 9/16" (116) base jamb depth measurement is from back side of installation flange.
- Light-colored areas are parts included with door. Dark-colored areas are additional Andersen® parts required to complete door assembly as shown.
- Dimensions in parentheses are in millimeters.
- **Minimum rough openings may need to be increased to allow for use of building wraps, flashing, sill panning, brackets, fasteners or other items. See installation information on page 226-227.**
- Details are for illustration only and are not intended to represent product installation methods or materials. Refer to product installation instructions at andersenwindows.com.

PATIO DOOR SIDELIGHTS & TRANSOMS

Table of Patio Door Transom and Sidelight Transom Sizes

Notes on page 158 also apply to this page.

Scale 1/8" (3) = 1'-0" (305) – 1:96

Transom Dimension	1'-2 1/4" (362)	1'-6 1/4" (464)	2'-0 1/8" (612)	2'-6 1/8" (765)	2'-8 1/8" (816)	3'-0 1/8" (918)	3'-2 1/8" (968)	3'-11 1/4" (1200)	4'-11 1/4" (1505)	5'-3 1/4" (1607)
Minimum Rough Opening	1'-3" (381)	1'-7" (483)	2'-1" (635)	2'-7" (787)	2'-9" (838)	3'-1" (940)	3'-3" (991)	4'-0" (1219)	5'-0" (1524)	5'-4" (1626)

CUSTOM WIDTHS AVAILABLE — Vary based on transom style.

















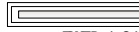

CUSTOM HEIGHTS — 11 1/4" to 27 1/4"



















Unobstructed Glass (single sash only)	6 3/8" (163)	10 3/8" (264)	12 7/8" (327)	18 7/8" (479)	20 7/8" (530)	24 7/8" (632)	26 7/8" (683)	36" (915)	48" (1220)	52" (1322)
11 1/4" (286)	FWSLTD-1-1310 FWSTCD-1-1310	FWSLTD-1-1710 FWSTCD-1-1710	FWTD-1-2110 FWTCD-1-2110	FWTD-1-2710 FWTCD-1-2710	FWTD-1-2910 FWTCD-1-2910	FWTD-1-3110 FWTCD-1-3110	FWTD-1-3310 FWTCD-1-3310	FWTD-1-4010 FWTCD-1-4010	FWTD-1-5010 FWTCD-1-5010	FWTD-1-5410 FWTCD-1-5410
11 1/4" (286)								FWTD-2-4010 FWTCD-2-4010	FWTD-2-5010 FWTCD-2-5010	FWTD-2-5410 FWTCD-2-5410
11 1/4" (286)	FWSTDS1310 FWSTCDS1310	FWSTDS1710 FWSTCDS1710	FWTDS2110 FWTCD-2-2110	FWTDS2710 FWTCD-2-2710	FWTDS2910 FWTCD-2-2910	FWTDS3110 FWTCD-2-3110	FWTDS3310 FWTCD-2-3310	FWTDS4010 FWTCD-2-4010	FWTDS5010 FWTCD-2-5010	FWTDS5410 FWTCD-2-5410
11 1/4" (286)										
1'-3 1/4" (387)	FWSLTD-1-1314 FWSTCD-1-1314	FWSLTD-1-1714 FWSTCD-1-1714	FWTD-1-2114 FWTCD-1-2114	FWTD-1-2714 FWTCD-1-2714	FWTD-1-2914 FWTCD-1-2914	FWTD-1-3114 FWTCD-1-3114	FWTD-1-3314 FWTCD-1-3314	FWTD-1-4014 FWTCD-1-4014	FWTD-1-5014 FWTCD-1-5014	FWTD-1-5414 FWTCD-1-5414
1'-3 1/4" (387)								FWTD-2-4014 FWTCD-2-4014	FWTD-2-5014 FWTCD-2-5014	FWTD-2-5414 FWTCD-2-5414
1'-3 1/4" (387)	FWSTDS1314 FWSTCDS1314	FWSTDS1714 FWSTCDS1714	FWTDS2114 FWTCD-2-2114	FWTDS2714 FWTCD-2-2714	FWTDS2914 FWTCD-2-2914	FWTDS3114 FWTCD-2-3114	FWTDS3314 FWTCD-2-3314	FWTDS4014 FWTCD-2-4014	FWTDS5014 FWTCD-2-5014	FWTDS5414 FWTCD-2-5414
1'-3 1/4" (387)										
1'-7 1/4" (489)	FWSLTD-1-1318 FWSTCD-1-1318	FWSLTD-1-1718 FWSTCD-1-1718	FWTD-1-2118 FWTCD-1-2118	FWTD-1-2718 FWTCD-1-2718	FWTD-1-2918 FWTCD-1-2918	FWTD-1-3118 FWTCD-1-3118	FWTD-1-3318 FWTCD-1-3318	FWTD-1-4018 FWTCD-1-4018	FWTD-1-5018 FWTCD-1-5018	FWTD-1-5418 FWTCD-1-5418
1'-7 1/4" (489)								FWTD-2-4018 FWTCD-2-4018	FWTD-2-5018 FWTCD-2-5018	FWTD-2-5418 FWTCD-2-5418
1'-7 1/4" (489)	FWSTDS1318 FWSTCDS1318	FWSTDS1718 FWSTCDS1718	FWTDS2118 FWTCD-2-2118	FWTDS2718 FWTCD-2-2718	FWTDS2918 FWTCD-2-2918	FWTDS3118 FWTCD-2-3118	FWTDS3318 FWTCD-2-3318	FWTDS4018 FWTCD-2-4018	FWTDS5018 FWTCD-2-5018	FWTDS5418 FWTCD-2-5418
1'-7 1/4" (489)										
1'-11 1/4" (591)	FWSLTD-1-1320 FWSTCD-1-1320	FWSLTD-1-1720 FWSTCD-1-1720	FWTD-1-2120 FWTCD-1-2120	FWTD-1-2720 FWTCD-1-2720	FWTD-1-2920 FWTCD-1-2920	FWTD-1-3120 FWTCD-1-3120	FWTD-1-3320 FWTCD-1-3320	FWTD-1-4020 FWTCD-1-4020	FWTD-1-5020 FWTCD-1-5020	FWTD-1-5420 FWTCD-1-5420



















* "Transom Dimension" always refers to outside frame-to-frame dimension.
 • "Minimum Rough Opening" dimensions may need to be increased to allow for use of building wraps, flashing, sill panning, brackets, fasteners or other items. See pages 226-227 for more details.
 • Dimensions in parentheses are in millimeters.







Notes on page 158 also apply to this page.

5'-11 ¹ / ₄ " (1810)	6'-3 ¹ / ₄ " (1911)	6'-11 ¹ / ₄ " (2114)	7'-10 ⁷ / ₁₆ " (2398)	7'-11 ¹ / ₄ " (2419)	8'-10 ⁷ / ₁₆ " (2703)	9'-4 ⁷ / ₁₆ " (2856)
6'-0" (1829)	6'-4" (1930)	7'-0" (2133)	7'-11" (2413)	8'-0" (2438)	8'-11" (2717)	9'-5" (2870)

60" (1525)	64" (1626)	72" (1830)	83 ³ / ₁₆ " (2113)	84" (2134)	95 ³ / ₁₆ " (2418)	101 ³ / ₁₆ " (2570)
 FWTD-1-6010 FWTC-1-6010	 FWTD-1-6410 FWTC-1-6410	 FWTD-1-7010 FWTC-1-7010	 FWTD-1-71110 FWTC-1-71110	 FWTD-1-8010 FWTC-1-8010	 FWTD-1-81110 FWTC-1-81110	 FWTD-1-9610 FWTC-1-9610
24 ⁷ / ₈ " (632)	26 ⁷ / ₈ " (683)		20 ⁷ / ₈ " (530)		24 ⁷ / ₈ " (632)	26 ⁷ / ₈ " (683)
 FWTD-2-6010 FWTC-2-6010	 FWTD-2-6410 FWTC-2-6410		 FWTD-3-71110 FWTC-3-71110		 FWTD-3-81110 FWTC-3-81110	 FWTD-3-9610 FWTC-3-9610
67 ⁵ / ₈ " (1717)	71 ⁵ / ₈ " (1818)	79 ⁵ / ₈ " (2022)	90 ³ / ₄ " (2305)	91 ⁵ / ₈ " (2326)	102 ³ / ₄ " (2610)	108 ³ / ₄ " (2762)
 FWTDS6010 FWTCDS6010	 FWTDS6410 FWTCDS6410	 FWTDS7010 FWTCDS7010	 FWTDS71110 FWTCDS71110	 FWTDS8010 FWTCDS8010	 FWTDS81110 FWTCDS81110	 FWTDS9610 FWTCDS9610

60" (1525)	64" (1626)	72" (1830)	83 ³ / ₁₆ " (2113)	84" (2134)	95 ³ / ₁₆ " (2418)	101 ³ / ₁₆ " (2570)
 FWTD-1-6014 FWTC-1-6014	 FWTD-1-6414 FWTC-1-6414	 FWTD-1-7014 FWTC-1-7014	 FWTD-1-71114 FWTC-1-71114	 FWTD-1-8014 FWTC-1-8014	 FWTD-1-81114 FWTC-1-81114	 FWTD-1-9614 FWTC-1-9614
24 ⁷ / ₈ " (632)	26 ⁷ / ₈ " (683)		20 ⁷ / ₈ " (530)		24 ⁷ / ₈ " (632)	26 ⁷ / ₈ " (683)
 FWTD-2-6014 FWTC-2-6014	 FWTD-2-6414 FWTC-2-6414		 FWTD-3-71114 FWTC-3-71114		 FWTD-3-81114 FWTC-3-81114	 FWTD-3-9614 FWTC-3-9614
67 ⁵ / ₈ " (1717)	71 ⁵ / ₈ " (1818)	79 ⁵ / ₈ " (2022)	90 ³ / ₄ " (2305)	91 ⁵ / ₈ " (2326)	102 ³ / ₄ " (2610)	108 ³ / ₄ " (2762)
 FWTDS6014 FWTCDS6014	 FWTDS6414 FWTCDS6414	 FWTDS7014 FWTCDS7014	 FWTDS71114 FWTCDS71114	 FWTDS8014 FWTCDS8014	 FWTDS81114 FWTCDS81114	 FWTDS9614 FWTCDS9614

60" (1525)	64" (1626)	72" (1830)	83 ³ / ₁₆ " (2113)	84" (2134)	95 ³ / ₁₆ " (2418)	101 ³ / ₁₆ " (2570)
 FWTD-1-6018 FWTC-1-6018	 FWTD-1-6418 FWTC-1-6418	 FWTD-1-7018 FWTC-1-7018	 FWTD-1-71118 FWTC-1-71118	 FWTD-1-8018 FWTC-1-8018	 FWTD-1-81118 FWTC-1-81118	 FWTD-1-9618 FWTC-1-9618
24 ⁷ / ₈ " (632)	26 ⁷ / ₈ " (683)		20 ⁷ / ₈ " (530)		24 ⁷ / ₈ " (632)	26 ⁷ / ₈ " (683)
 FWTD-2-6018 FWTC-2-6018	 FWTD-2-6418 FWTC-2-6418		 FWTD-3-71118 FWTC-3-71118		 FWTD-3-81118 FWTC-3-81118	 FWTD-3-9618 FWTC-3-9618
67 ⁵ / ₈ " (1717)	71 ⁵ / ₈ " (1818)	79 ⁵ / ₈ " (2022)	90 ³ / ₄ " (2305)	91 ⁵ / ₈ " (2326)	102 ³ / ₄ " (2610)	108 ³ / ₄ " (2762)
 FWTDS6018 FWTCDS6018	 FWTDS6418 FWTCDS6418	 FWTDS7018 FWTCDS7018	 FWTDS71118 FWTCDS71118	 FWTDS8018 FWTCDS8018	 FWTDS81118 FWTCDS81118	 FWTDS9618 FWTCDS9618

60" (1525)	64" (1626)	72" (1830)	83 ³ / ₁₆ " (2113)	84" (2134)	95 ³ / ₁₆ " (2418)	101 ³ / ₁₆ " (2570)
 FWTD-1-6020 FWTC-1-6020	 FWTD-1-6420 FWTC-1-6420	 FWTD-1-7020 FWTC-1-7020	 FWTD-1-71120 FWTC-1-71120	 FWTD-1-8020 FWTC-1-8020	 FWTD-1-81120 FWTC-1-81120	 FWTD-1-9620 FWTC-1-9620

* "Transom Dimension" always refers to outside frame-to-frame dimension.
 • "Minimum Rough Opening" dimensions may need to be increased to allow for use of building wraps, flashing, sill panning, brackets, fasteners or other items. See pages 226-227 for more details.
 • Dimensions in parentheses are in millimeters.

continued on next page

PATIO DOOR SIDELIGHTS & TRANSOMS

Table of Patio Door Transom and Sidelight Transom Sizes (continued)

Scale 1/8" (3) = 1'-0" (305) – 1:96

Transom Dimension	1'-2 1/4"	1'-6 1/4"	2'-0 1/8"	2'-6 1/8"	2'-8 1/8"	3'-0 1/8"	3'-2 1/8"	3'-11 1/4"	4'-11 1/4"	5'-3 1/4"
	(362)	(464)	(612)	(765)	(816)	(918)	(968)	(1200)	(1505)	(1607)
Minimum Rough Opening	1'-3"	1'-7"	2'-1"	2'-7"	2'-9"	3'-1"	3'-3"	4'-0"	5'-0"	5'-4"
	(381)	(483)	(635)	(787)	(838)	(940)	(991)	(1219)	(1524)	(1626)

Unobstructed Glass (single sash only)

CUSTOM WIDTHS AVAILABLE — Vary based on transom style.

Unobstructed Glass (single sash only)	10 5/8"	14 5/8"	20 7/16"	26 7/16"	28 7/16"	32 7/16"	34 7/16"	43 5/8"	55 5/8"	59 5/8"
1'-11 1/4" (591)	(269)	(371)	(519)	(672)	(722)	(824)	(875)	(1107)	(1412)	(1514)
1'-11 1/4" (591)	FWSTDS1320	FWSTDS1720	FWTDS2120	FWTDS2720	FWTDS2920	FWTDS3120	FWTDS3320	FWTDS4020	FWTDS5020	FWTDS5420
	FWSTCDS1320	FWSTCDS1720	FWTDCDS2120	FWTDCDS2720	FWTDCDS2920	FWTDCDS3120	FWTDCDS3320	FWTDCDS4020	FWTDCDS5020	FWTDCDS5420
2'-3 1/4" (692)	6 3/8" (163)	10 3/8" (264)	12 7/8" (327)	18 7/8" (479)	20 7/8" (530)	24 7/8" (632)	26 7/8" (683)	36" (915)	48" (1220)	52" (1322)
2'-3 1/4" (692)	FWSLTD-1-1324	FWSLTD-1-1724	FWTD-1-2124	FWTD-1-2724	FWTD-1-2924	FWTD-1-3124	FWTD-1-3324	FWTD-1-4024	FWTD-1-5024	FWTD-1-5424
	FWSTCD-1-1324	FWSTCD-1-1724	FWTCD-1-2124	FWTCD-1-2724	FWTCD-1-2924	FWTCD-1-3124	FWTCD-1-3324	FWTCD-1-4024	FWTCD-1-5024	FWTCD-1-5424
2'-3 1/4" (692)	12 7/8" (327)	18 7/8" (479)	20 7/8" (530)							
2'-3 1/4" (692)	FWTD-2-4024	FWTD-2-5024	FWTD-2-5424							
	FWTCD-2-4024	FWTCD-2-5024	FWTCD-2-5424							
2'-3 1/4" (692)	10 5/8" (269)	14 5/8" (371)	20 7/16" (519)	26 7/16" (672)	28 7/16" (722)	32 7/16" (824)	34 7/16" (875)	43 5/8" (1107)	55 5/8" (1412)	59 5/8" (1514)
2'-3 1/4" (692)	FWSTDS1324	FWSTDS1724	FWTDS2124	FWTDS2724	FWTDS2924	FWTDS3124	FWTDS3324	FWTDS4024	FWTDS5024	FWTDS5424
	FWSTCDS1324	FWSTCDS1724	FWTDCDS2124	FWTDCDS2724	FWTDCDS2924	FWTDCDS3124	FWTDCDS3324	FWTDCDS4024	FWTDCDS5024	FWTDCDS5424



Custom-size patio door transoms are available in 1/8" (3) increments.

See pages 174-175 for custom sizes and specifications.

Transoms with either traditional or contemporary glass stops are available either direct-set or sash-set. Direct-set transoms provide maximum unobstructed glass. For venting transom windows, see page 160. For patio door sidelights, see page 161.

Grille patterns shown on page 164. Details shown on pages 164-167.



Direct-Set Patio Door Sidelight Transom
Traditional (FWSTDS)/Contemporary (FWSTCDS)



Sash-Set Patio Door Sidelight Transom
Traditional (FWSLTD)/Contemporary (FWSTCD)

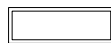

Direct-Set Patio Door Transom
Traditional (FWTDS)/Contemporary (FWTDCS)

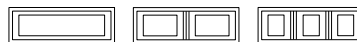

Sash-Set Patio Door Transoms
Traditional (FWTD-1, FWTD-2, FWTD-3)/Contemporary (FWTCD-1, FWTCD-2, FWTCD-3)

* "Transom Dimension" always refers to outside frame-to-frame dimension.

** "Minimum Rough Opening" dimensions may need to be increased to allow for use of building wraps, flashing, sill panning, brackets, fasteners or other items. See pages 226-227 for more details.

• Dimensions in parentheses are in millimeters.

Notes on the previous page also apply to this page.

5'-11 ¹ / ₄ " (1810)	6'-3 ¹ / ₄ " (1911)	6'-11 ¹ / ₄ " (2114)	7'-10 ⁷ / ₁₆ " (2398)	7'-11 ¹ / ₄ " (2419)	8'-10 ⁷ / ₁₆ " (2703)	9'-4 ⁷ / ₁₆ " (2856)
6'-0" (1829)	6'-4" (1930)	7'-0" (2133)	7'-11" (2413)	8'-0" (2438)	8'-11" (2717)	9'-5" (2870)

24 ⁷ / ₈ " (632)	26 ⁷ / ₈ " (683)	20 ⁷ / ₈ " (530)	24 ⁷ / ₈ " (632)	26 ⁷ / ₈ " (683)
FWTD-2-6020 FWTCDS-2-6020	FWTD-2-6420 FWTCDS-2-6420	FWTD-3-71120 FWTCDS-3-71120	FWTD-3-81120 FWTCDS-3-81120	FWTD-3-9620 FWTCDS-3-9620

67 ⁵ / ₈ " (1717)	71 ⁵ / ₈ " (1818)	79 ⁵ / ₈ " (2022)	90 ³ / ₄ " (2305)	91 ⁵ / ₈ " (2326)	102 ³ / ₄ " (2610)	108 ³ / ₄ " (2762)
FWTD6020 FWTCDS6020	FWTD6420 FWTCDS6420	FWTD7020 FWTCDS7020	FWTD71120 FWTCDS71120	FWTD8020 FWTCDS8020	FWTD81120 FWTCDS81120	FWTD9620 FWTCDS9620

60" (1525)	64" (1626)	72" (1830)	83 ³ / ₁₆ " (2113)	84" (2134)	95 ³ / ₁₆ " (2418)	101 ³ / ₁₆ " (2570)
FWTD-1-6024 FWTCDS-1-6024	FWTD-1-6424 FWTCDS-1-6424	FWTD-1-7024 FWTCDS-1-7024	FWTD-1-71124 FWTCDS-1-71124	FWTD-1-8024 FWTCDS-1-8024	FWTD-1-81124 FWTCDS-1-81124	FWTD-1-9624 FWTCDS-1-9624

24 ⁷ / ₈ " (632)	26 ⁷ / ₈ " (683)	20 ⁷ / ₈ " (530)	24 ⁷ / ₈ " (632)	26 ⁷ / ₈ " (683)
FWTD-2-6024 FWTCDS-2-6024	FWTD-2-6424 FWTCDS-2-6424	FWTD-3-71124 FWTCDS-3-71124	FWTD-3-81124 FWTCDS-3-81124	FWTD-3-9624 FWTCDS-3-9624

67 ⁵ / ₈ " (1717)	71 ⁵ / ₈ " (1818)	79 ⁵ / ₈ " (2022)	90 ³ / ₄ " (2305)	91 ⁵ / ₈ " (2326)	102 ³ / ₄ " (2610)	108 ³ / ₄ " (2762)
FWTD6024 FWTCDS6024	FWTD6424 FWTCDS6424	FWTD7024 FWTCDS7024	FWTD71124 FWTCDS71124	FWTD8024 FWTCDS8024	FWTD81124 FWTCDS81124	FWTD9624 FWTCDS9624

• "Transom Dimension" always refers to outside frame-to-frame dimension.
 • "Minimum Rough Opening" dimensions may need to be increased to allow for use of building wraps, flashing, sill panning, brackets, fasteners or other items. See pages 226-227 for more details.
 • Dimensions in parentheses are in millimeters.

PATIO DOOR SIDELIGHTS & TRANSOMS

Table of Venting Transom Window Sizes

Scale 1/8" (3) = 1'-0" (305) – 1:96

Window Dimension	2'-0 1/8"	2'-6 1/8"	2'-8 1/8"	3'-0 1/8"	3'-2 1/8"	3'-11 1/4"	4'-11 1/4"	5'-3 1/4"	5'-11 1/4"
	(612)	(765)	(816)	(918)	(968)	(1200)	(1505)	(1607)	(1810)
Minimum Rough Opening	2'-1"	2'-7"	2'-9"	3'-1"	3'-3"	4'-0"	5'-0"	5'-4"	6'-0"
	(635)	(787)	(838)	(940)	(991)	(1219)	(1524)	(1626)	(1829)

Unobstructed Glass (single sash only)	CUSTOM SIZES AVAILABLE									
	17 5/8"	23 5/8"	25 5/8"	29 5/8"	31 5/8"	40 5/8"	52 5/8"	56 5/8"	64 5/8"	
1'-3 1/4" (387)	17 5/8" (448)	23 5/8" (600)	25 5/8" (651)	29 5/8" (752)	31 5/8" (803)	40 5/8" (1032)	52 5/8" (1337)	56 5/8" (1438)	64 5/8" (1641)	
1'-4" (406)	17 5/8" (448)	23 5/8" (600)	25 5/8" (651)	29 5/8" (752)	31 5/8" (803)	40 5/8" (1032)	52 5/8" (1337)	56 5/8" (1438)	64 5/8" (1641)	
1'-7 1/4" (489)	17 5/8" (448)	23 5/8" (600)	25 5/8" (651)	29 5/8" (752)	31 5/8" (803)	40 5/8" (1032)	52 5/8" (1337)	56 5/8" (1438)	64 5/8" (1641)	
1'-8" (508)	17 5/8" (448)	23 5/8" (600)	25 5/8" (651)	29 5/8" (752)	31 5/8" (803)	40 5/8" (1032)	52 5/8" (1337)	56 5/8" (1438)	64 5/8" (1641)	
1'-11 1/4" (591)	17 5/8" (448)	23 5/8" (600)	25 5/8" (651)	29 5/8" (752)	31 5/8" (803)	40 5/8" (1032)	52 5/8" (1337)	56 5/8" (1438)	64 5/8" (1641)	
2'-0" (610)	17 5/8" (448)	23 5/8" (600)	25 5/8" (651)	29 5/8" (752)	31 5/8" (803)	40 5/8" (1032)	52 5/8" (1337)	56 5/8" (1438)	64 5/8" (1641)	
16 5/8" (422)	17 5/8" (448)	23 5/8" (600)	25 5/8" (651)	29 5/8" (752)	31 5/8" (803)	40 5/8" (1032)	52 5/8" (1337)	56 5/8" (1438)	64 5/8" (1641)	
2'-3 1/4" (692)	17 5/8" (448)	23 5/8" (600)	25 5/8" (651)	29 5/8" (752)	31 5/8" (803)	40 5/8" (1032)	52 5/8" (1337)	56 5/8" (1438)	64 5/8" (1641)	
2'-4" (711)	17 5/8" (448)	23 5/8" (600)	25 5/8" (651)	29 5/8" (752)	31 5/8" (803)	40 5/8" (1032)	52 5/8" (1337)	56 5/8" (1438)	64 5/8" (1641)	
20 5/8" (524)	17 5/8" (448)	23 5/8" (600)	25 5/8" (651)	29 5/8" (752)	31 5/8" (803)	40 5/8" (1032)	52 5/8" (1337)	56 5/8" (1438)	64 5/8" (1641)	
	ATV2114	ATV2714	ATV2914	ATV3114	ATV3314	ATV4014	ATV5014	ATV5414	ATV6014	
	ATV2118	ATV2718	ATV2918	ATV3118	ATV3318	ATV4018	ATV5018	ATV5418	ATV6018	
	ATV2120	ATV2720	ATV2920	ATV3120	ATV3320	ATV4020	ATV5020	ATV5420	ATV6020	
	ATV2124	ATV2724	ATV2924	ATV3124	ATV3324	ATV4024	ATV5024	ATV5424	ATV6024	



Custom-size venting transoms are available in 1/8" (3) increments.

See page 69 for custom sizes and specifications.

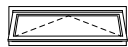

Venting Transom Window (ATV)

Venting transom windows have traditional glass stops and match patio doors with traditional panels.*

Grille patterns shown in the window section on page 58.

Details shown on page 166.

*"Window Dimension" always refers to outside frame-to-frame dimension.
 *"Minimum Rough Opening" dimensions may need to be increased to allow for use of building wraps, flashing, sill panning, brackets, fasteners or other items. See pages 226-227 for more details.
 • Dimensions in parentheses are in millimeters.
 • Venting transom windows are not available with contemporary glass stops.

Table of Patio Door Sidelight Sizes

Scale 1/8" (3) = 1'-0" (305) – 1:96

Sidelight Dimension	1'-2 1/4" (362)	1'-2 1/4" (362)	1'-6 1/4" (464)	1'-6 1/4" (464)
Minimum Rough Opening	1'-3" (381)	1'-3" (381)	1'-7" (483)	1'-7" (483)
Unobstructed Glass (height shown left of sidelight)	6 3/8" (163)	6 3/8" (163)	10 3/8" (264)	10 3/8" (264)



Custom-size patio door sidelights are available in 1/8" (3) increments. See page 175 for custom sizes and specifications.

Choose traditional (**FWSLD**) or contemporary (**FWSLCD**) panel. For patio door transoms, see pages 156-160.

Grille patterns shown on page 164. Details shown on pages 165 and 167.

		CUSTOM WIDTHS – 14 1/4" to 18 1/4"			
CUSTOM HEIGHTS – 78" to 119 1/2"	6'-7 1/2" (2019)	63 7/16" (1611)	67 1/2" (1714)	63 7/16" (1611)	67 1/2" (1714)
		FWSLD-1-1368	FWSLCD-1-1368	FWSLD-1-1768	FWSLCD-1-1768
	6'-10 3/8" (2092)	66 5/16" (1684)	70 3/8" (1787)	66 5/16" (1684)	70 3/8" (1787)
		FWSLD-1-13611	FWSLCD-1-13611	FWSLD-1-17611	FWSLCD-1-17611
7'-11 1/2" (2426)	79 7/16" (2018)	83 1/2" (2121)	79 7/16" (2018)	83 1/2" (2121)	
	FWSLD-1-1380	FWSLCD-1-1380	FWSLD-1-1780	FWSLCD-1-1780	
9'-11 1/2" (3035)	103 5/16" (2624)	107 1/2" (2730)	103 5/16" (2624)	107 1/2" (2730)	
	FWSLD-1-13100	FWSLCD-1-13100	FWSLD-1-17100	FWSLCD-1-17100	

- * "Sidelight Dimension" always refers to outside frame-to-frame dimension.
- * "Minimum Rough Opening" dimensions may need to be increased to allow for use of building wraps, flashing, sill panning, brackets, fasteners or other items. See pages 226-227 for more details.
- * Dimensions in parentheses are in millimeters.

Patio Door Sidelight Area Specifications

Sidelight Number	Traditional Panel Glass Area Sq. Ft./ (m ²)	Contemporary Panel Glass Area Sq. Ft./ (m ²)	Overall Door Area Sq. Ft./ (m ²)
FWSLD/FWSLCD1368	2.82 (0.26)	3.00 (0.28)	7.87 (0.73)
FWSLD/FWSLCD13611	2.95 (0.27)	3.13 (0.29)	8.15 (0.76)
FWSLD/FWSLCD1380	3.53 (0.33)	3.71 (0.34)	9.45 (0.88)
FWSLD/FWSLCD13100	4.60 (0.43)	4.78 (0.44)	11.83 (1.10)
FWSLD/FWSLCD1768	4.58 (0.43)	4.88 (0.45)	10.08 (0.94)
FWSLD/FWSLCD17611	4.79 (0.44)	5.09 (0.47)	10.44 (0.97)
FWSLD/FWSLCD1780	5.74 (0.53)	6.03 (0.56)	12.10 (1.12)
FWSLD/FWSLCD17100	7.47 (0.69)	7.77 (0.72)	15.14 (1.41)

* Dimensions in parentheses are in square meters.

PATIO DOOR SIDELIGHTS & TRANSOMS

Direct-Set Patio Door Transom and Sidelight Transom Area Specifications

Transom Number	Glass Area Sq. Ft./ (m ²)	Overall Transom Area Sq. Ft./ (m ²)
FWSTDS/FWSTCDS1310	0.56 (0.05)	1.11 (0.10)
FWSTDS/FWSTCDS1314	0.85 (0.08)	1.51 (0.14)
FWSTDS/FWSTCDS1318	1.15 (0.11)	1.90 (0.18)
FWSTDS/FWSTCDS1320	1.44 (0.13)	2.30 (0.21)
FWSTDS/FWSTCDS1324	1.74 (0.16)	2.70 (0.25)
FWSTDS/FWSTCDS1710	0.77 (0.07)	1.43 (0.13)
FWSTDS/FWSTCDS1714	1.18 (0.11)	1.93 (0.18)
FWSTDS/FWSTCDS1718	1.58 (0.15)	2.44 (0.23)
FWSTDS/FWSTCDS1720	1.99 (0.18)	2.95 (0.27)
FWSTDS/FWSTCDS1724	2.39 (0.22)	3.45 (0.32)
FWTDS/FWTCDS2110	1.08 (0.10)	1.88 (0.17)
FWTDS/FWTCDS2114	1.65 (0.15)	2.55 (0.24)
FWTDS/FWTCDS2118	2.21 (0.21)	3.22 (0.30)
FWTDS/FWTCDS2120	2.78 (0.26)	3.89 (0.36)
FWTDS/FWTCDS2124	3.35 (0.31)	4.56 (0.42)
FWTDS/FWTCDS2710	1.39 (0.13)	2.35 (0.22)
FWTDS/FWTCDS2714	2.13 (0.20)	3.19 (0.30)
FWTDS/FWTCDS2718	2.86 (0.27)	4.02 (0.37)
FWTDS/FWTCDS2720	3.60 (0.33)	4.86 (0.45)
FWTDS/FWTCDS2724	4.33 (0.40)	5.69 (0.53)
FWTDS/FWTCDS2910	1.50 (0.14)	2.51 (0.23)
FWTDS/FWTCDS2914	2.29 (0.21)	3.40 (0.32)
FWTDS/FWTCDS2918	3.08 (0.29)	4.29 (0.40)
FWTDS/FWTCDS2920	3.87 (0.36)	5.18 (0.48)
FWTDS/FWTCDS2924	4.66 (0.43)	6.07 (0.56)
FWTDS/FWTCDS3110	1.71 (0.16)	2.82 (0.26)
FWTDS/FWTCDS3114	2.61 (0.24)	3.82 (0.36)
FWTDS/FWTCDS3118	3.51 (0.33)	4.83 (0.45)
FWTDS/FWTCDS3120	4.41 (0.41)	5.83 (0.54)
FWTDS/FWTCDS3124	5.31 (0.49)	6.83 (0.63)
FWTDS/FWTCDS3310	1.82 (0.17)	2.98 (0.28)
FWTDS/FWTCDS3314	2.77 (0.26)	4.03 (0.37)
FWTDS/FWTCDS3318	3.73 (0.35)	5.09 (0.47)
FWTDS/FWTCDS3320	4.69 (0.44)	6.15 (0.57)
FWTDS/FWTCDS3324	5.64 (0.52)	7.21 (0.67)
FWTDS/FWTCDS4010	2.30 (0.21)	3.69 (0.34)
FWTDS/FWTCDS4014	3.51 (0.33)	5.00 (0.46)
FWTDS/FWTCDS4018	4.72 (0.44)	6.32 (0.59)
FWTDS/FWTCDS4020	5.93 (0.55)	7.63 (0.71)
FWTDS/FWTCDS4024	7.14 (0.66)	8.94 (0.83)
FWTDS/FWTCDS5010	2.93 (0.27)	4.63 (0.43)
FWTDS/FWTCDS5014	4.48 (0.42)	6.27 (0.58)
FWTDS/FWTCDS5018	6.02 (0.56)	7.92 (0.74)
FWTDS/FWTCDS5020	7.56 (0.70)	9.57 (0.89)
FWTDS/FWTCDS5024	9.11 (0.85)	11.21 (1.04)
FWTDS/FWTCDS5410	3.14 (0.29)	4.94 (0.46)
FWTDS/FWTCDS5414	4.80 (0.45)	6.70 (0.62)
FWTDS/FWTCDS5418	6.45 (0.60)	8.46 (0.79)
FWTDS/FWTCDS5420	8.11 (0.75)	10.21 (0.95)
FWTDS/FWTCDS5424	9.76 (0.91)	11.97 (1.11)
FWTDS/FWTCDS6010	3.56 (0.33)	5.57 (0.52)
FWTDS/FWTCDS6014	5.44 (0.51)	7.55 (0.70)
FWTDS/FWTCDS6018	7.32 (0.68)	9.52 (0.88)
FWTDS/FWTCDS6020	9.20 (0.85)	11.50 (1.07)
FWTDS/FWTCDS6024	11.08 (1.03)	13.48 (1.25)
FWTDS/FWTCDS6410	3.78 (0.35)	5.88 (0.55)
FWTDS/FWTCDS6414	5.76 (0.54)	7.97 (0.74)
FWTDS/FWTCDS6418	7.75 (0.72)	10.06 (0.93)
FWTDS/FWTCDS6420	9.74 (0.90)	12.15 (1.13)
FWTDS/FWTCDS6424	11.73 (1.09)	14.24 (1.32)

Transom Number	Glass Area Sq. Ft./ (m ²)	Overall Transom Area Sq. Ft./ (m ²)
FWTDS/FWTCDS7010	4.20 (0.39)	6.50 (0.60)
FWTDS/FWTCDS7014	6.41 (0.60)	8.82 (0.82)
FWTDS/FWTCDS7018	8.62 (0.80)	11.13 (1.03)
FWTDS/FWTCDS7020	10.83 (1.01)	13.44 (1.25)
FWTDS/FWTCDS7024	13.04 (1.21)	15.75 (1.46)
FWTDS/FWTCDS71110	4.79 (0.44)	7.38 (0.69)
FWTDS/FWTCDS71114	7.31 (0.68)	10.00 (0.93)
FWTDS/FWTCDS71118	9.83 (0.91)	12.62 (1.17)
FWTDS/FWTCDS71120	12.35 (1.15)	15.24 (1.42)
FWTDS/FWTCDS71124	14.87 (1.38)	17.87 (1.66)
FWTDS/FWTCDS8010	4.83 (0.45)	7.44 (0.69)
FWTDS/FWTCDS8014	7.37 (0.68)	10.09 (0.94)
FWTDS/FWTCDS8018	9.92 (0.92)	12.73 (1.18)
FWTDS/FWTCDS8020	12.46 (1.16)	15.38 (1.43)
FWTDS/FWTCDS8024	15.01 (1.39)	18.02 (1.67)
FWTDS/FWTCDS81110	5.42 (0.50)	8.31 (0.77)
FWTDS/FWTCDS81114	8.27 (0.77)	11.27 (1.05)
FWTDS/FWTCDS81118	11.13 (1.03)	14.22 (1.32)
FWTDS/FWTCDS81120	13.98 (1.30)	17.18 (1.60)
FWTDS/FWTCDS81124	16.84 (1.56)	20.14 (1.87)
FWTDS/FWTCDS9610	5.74 (0.53)	8.78 (0.82)
FWTDS/FWTCDS9614	8.76 (0.81)	11.90 (1.11)
FWTDS/FWTCDS9618	11.78 (1.09)	15.03 (1.40)
FWTDS/FWTCDS9620	14.80 (1.37)	18.15 (1.69)
FWTDS/FWTCDS9624	17.82 (1.66)	21.27 (1.98)

* Dimensions in parentheses are in square meters.

Sash-Set Patio Door Transom and Sidelight Transom Area Specifications

Transom Number	Glass Area Sq. Ft./ (m ²)	Overall Transom Area Sq. Ft./ (m ²)
FWSLTD/FWSTCD1310	0.15 (0.01)	1.11 (0.10)
FWSLTD/FWSTCD1314	0.33 (0.03)	1.51 (0.14)
FWSLTD/FWSTCD1318	0.51 (0.05)	1.90 (0.18)
FWSLTD/FWSTCD1320	0.69 (0.06)	2.30 (0.21)
FWSLTD/FWSTCD1324	0.86 (0.08)	2.70 (0.25)
FWSLTD/FWSTCD1710	0.25 (0.02)	1.43 (0.13)
FWSLTD/FWSTCD1714	0.54 (0.05)	1.93 (0.18)
FWSLTD/FWSTCD1718	0.82 (0.08)	2.44 (0.23)
FWSLTD/FWSTCD1720	1.11 (0.10)	2.95 (0.27)
FWSLTD/FWSTCD1724	1.40 (0.13)	3.45 (0.32)
FWTD/FWTCDD-1-2110	0.30 (0.03)	1.88 (0.17)
FWTD/FWTCDD-1-2114	0.66 (0.06)	2.55 (0.24)
FWTD/FWTCDD-1-2118	1.02 (0.09)	3.22 (0.30)
FWTD/FWTCDD-1-2120	1.38 (0.13)	3.89 (0.36)
FWTD/FWTCDD-1-2124	1.73 (0.16)	4.56 (0.42)
FWTD/FWTCDD-1-2710	0.45 (0.04)	2.35 (0.22)
FWTD/FWTCDD-1-2714	0.97 (0.09)	3.19 (0.30)
FWTD/FWTCDD-1-2718	1.49 (0.14)	4.02 (0.37)
FWTD/FWTCDD-1-2720	2.02 (0.19)	4.86 (0.45)
FWTD/FWTCDD-1-2724	2.54 (0.24)	5.69 (0.53)
FWTD/FWTCDD-1-2910	0.49 (0.05)	2.51 (0.23)
FWTD/FWTCDD-1-2914	1.07 (0.10)	3.40 (0.32)
FWTD/FWTCDD-1-2918	1.65 (0.15)	4.29 (0.40)
FWTD/FWTCDD-1-2920	2.23 (0.21)	5.18 (0.48)
FWTD/FWTCDD-1-2924	2.81 (0.26)	6.07 (0.56)
FWTD/FWTCDD-1-3110	0.59 (0.05)	2.82 (0.26)
FWTD/FWTCDD-1-3114	1.28 (0.12)	3.82 (0.35)

Transom Number	Glass Area Sq. Ft./ (m ²)	Overall Transom Area Sq. Ft./ (m ²)
FWTD/FWTCDD-1-3118	1.97 (0.18)	4.83 (0.45)
FWTD/FWTCDD-1-3120	2.66 (0.25)	5.83 (0.54)
FWTD/FWTCDD-1-3124	3.35 (0.31)	6.83 (0.63)
FWTD/FWTCDD-1-3310	0.64 (0.06)	2.98 (0.28)
FWTD/FWTCDD-1-3314	1.38 (0.13)	4.03 (0.37)
FWTD/FWTCDD-1-3318	2.13 (0.20)	5.09 (0.47)
FWTD/FWTCDD-1-3320	2.88 (0.27)	6.15 (0.57)
FWTD/FWTCDD-1-3324	3.62 (0.34)	7.21 (0.67)
FWTD/FWTCDD-1-4010	0.85 (0.08)	3.69 (0.34)
FWTD/FWTCDD-2-4010	0.61 (0.06)	3.69 (0.34)
FWTD/FWTCDD-1-4014	1.85 (0.17)	5.00 (0.46)
FWTD/FWTCDD-2-4014	1.32 (0.12)	5.00 (0.46)
FWTD/FWTCDD-1-4018	2.85 (0.26)	6.32 (0.59)
FWTD/FWTCDD-2-4018	2.04 (0.19)	6.32 (0.59)
FWTD/FWTCDD-1-4020	3.85 (0.36)	7.63 (0.71)
FWTD/FWTCDD-2-4020	2.75 (0.26)	7.63 (0.71)
FWTD/FWTCDD-1-4024	4.86 (0.45)	8.94 (0.83)
FWTD/FWTCDD-2-4024	3.47 (0.32)	8.94 (0.83)
FWTD/FWTCDD-1-5010	1.14 (0.11)	4.63 (0.43)
FWTD/FWTCDD-2-5010	0.89 (0.08)	4.63 (0.43)
FWTD/FWTCDD-1-5014	2.47 (0.23)	6.27 (0.58)
FWTD/FWTCDD-2-5014	1.94 (0.18)	6.27 (0.58)
FWTD/FWTCDD-1-5018	3.80 (0.35)	7.92 (0.74)
FWTD/FWTCDD-2-5018	2.99 (0.28)	7.92 (0.74)
FWTD/FWTCDD-1-5020	5.14 (0.48)	9.57 (0.89)
FWTD/FWTCDD-2-5020	4.04 (0.38)	9.57 (0.89)
FWTD/FWTCDD-1-5024	6.47 (0.60)	11.21 (1.04)
FWTD/FWTCDD-2-5024	5.09 (0.47)	11.21 (1.04)
FWTD/FWTCDD-1-5410	1.23 (0.11)	4.94 (0.46)
FWTD/FWTCDD-2-5410	0.99 (0.09)	4.94 (0.46)
FWTD/FWTCDD-1-5414	2.68 (0.25)	6.70 (0.62)
FWTD/FWTCDD-2-5414	2.15 (0.20)	6.70 (0.62)
FWTD/FWTCDD-1-5418	4.12 (0.38)	8.46 (0.79)
FWTD/FWTCDD-2-5418	3.31 (0.31)	8.46 (0.79)
FWTD/FWTCDD-1-5420	5.57 (0.52)	10.21 (0.95)
FWTD/FWTCDD-2-5420	4.47 (0.42)	10.21 (0.95)
FWTD/FWTCDD-1-5424	7.01 (0.65)	11.97 (1.11)
FWTD/FWTCDD-2-5424	5.63 (0.52)	11.97 (1.11)
FWTD/FWTCDD-1-6010	1.42 (0.13)	5.57 (0.52)
FWTD/FWTCDD-2-6010	1.18 (0.11)	5.57 (0.52)
FWTD/FWTCDD-1-6014	3.09 (0.29)	7.55 (0.70)
FWTD/FWTCDD-2-6014	2.56 (0.24)	7.55 (0.70)
FWTD/FWTCDD-1-6018	4.75 (0.44)	9.52 (0.88)
FWTD/FWTCDD-2-6018	3.94 (0.37)	9.52 (0.88)
FWTD/FWTCDD-1-6020	6.42 (0.60)	11.50 (1.07)
FWTD/FWTCDD-2-6020	5.32 (0.49)	11.50 (1.07)
FWTD/FWTCDD-1-6024	8.09 (0.75)	13.48 (1.25)
FWTD/FWTCDD-2-6024	6.70 (0.62)	13.48 (1.25)
FWTD/FWTCDD-1-6410	1.51 (0.14)	5.88 (0.55)
FWTD/FWTCDD-2-6410	1.27 (0.12)	5.88 (0.55)
FWTD/FWTCDD-1-6414	3.29 (0.31)	7.97 (0.74)
FWTD/FWTCDD-2-6414	2.76 (0.26)	7.97 (0.74)
FWTD/FWTCDD-1-6418	5.07 (0.47)	10.06 (0.93)
FWTD/FWTCDD-2-6418	4.26 (0.40)	10.06 (0.93)
FWTD/FWTCDD-1-6420	6.85 (0.64)	12.15 (1.13)
FWTD/FWTCDD-2-6420	5.75 (0.53)	12.15 (1.13)
FWTD/FWTCDD-1-6424	8.63 (0.80)	14.24 (1.32)
FWTD/FWTCDD-2-6424	7.24 (0.67)	14.24 (1.32)
FWTD/FWTCDD-1-7010	1.70 (0.16)	6.50 (0.60)

* Dimensions in parentheses are in square meters.

continued

Sash-Set Patio Door Transom and Sidelight Transom Area Specifications *(continued)*

Transom Number	Glass Area Sq. Ft./ (m ²)	Overall Transom Area Sq. Ft./ (m ²)
FWTD/FWTC-1-7014	3.70 (0.34)	8.82 (0.82)
FWTD/FWTC-1-7018	5.71 (0.53)	11.13 (1.03)
FWTD/FWTC-1-7020	7.71 (0.72)	13.44 (1.25)
FWTD/FWTC-1-7024	9.71 (0.90)	15.75 (1.46)
FWTD/FWTC-1-71110	1.97 (0.18)	7.38 (0.69)
FWTD/FWTC-3-71110	1.48 (0.14)	7.38 (0.69)
FWTD/FWTC-1-71114	4.28 (0.40)	10.00 (0.93)
FWTD/FWTC-3-71114	3.22 (0.30)	10.00 (0.93)
FWTD/FWTC-1-71118	6.59 (0.61)	12.62 (1.17)
FWTD/FWTC-3-71118	4.95 (0.46)	12.62 (1.17)
FWTD/FWTC-1-71120	8.90 (0.83)	15.24 (1.42)
FWTD/FWTC-3-71120	6.69 (0.62)	15.24 (1.42)
FWTD/FWTC-1-71124	11.21 (1.04)	17.87 (1.66)
FWTD/FWTC-3-71124	8.43 (0.78)	17.87 (1.66)
FWTD/FWTC-1-8010	1.99 (0.18)	7.44 (0.69)
FWTD/FWTC-1-8014	4.32 (0.40)	10.09 (0.94)
FWTD/FWTC-1-8018	6.66 (0.62)	12.73 (1.18)
FWTD/FWTC-1-8020	8.99 (0.84)	15.38 (1.43)
FWTD/FWTC-1-8024	11.32 (1.05)	18.02 (1.67)
FWTD/FWTC-1-81110	2.25 (0.21)	8.31 (0.77)
FWTD/FWTC-3-81110	1.76 (0.16)	8.31 (0.77)
FWTD/FWTC-1-81114	4.90 (0.46)	11.27 (1.05)
FWTD/FWTC-3-81114	3.83 (0.36)	11.27 (1.05)
FWTD/FWTC-1-81118	7.54 (0.70)	14.22 (1.32)
FWTD/FWTC-3-81118	5.90 (0.55)	14.22 (1.32)
FWTD/FWTC-1-81120	10.18 (0.95)	17.18 (1.60)
FWTD/FWTC-3-81120	7.97 (0.74)	17.18 (1.60)
FWTD/FWTC-1-81124	12.83 (1.19)	20.14 (1.87)
FWTD/FWTC-3-81124	10.05 (0.93)	20.14 (1.87)
FWTD/FWTC-1-9610	2.39 (0.22)	8.78 (0.82)
FWTD/FWTC-3-9610	1.91 (0.18)	8.78 (0.82)
FWTD/FWTC-1-9614	5.20 (0.48)	11.90 (1.11)
FWTD/FWTC-3-9614	4.14 (0.38)	11.90 (1.11)
FWTD/FWTC-1-9618	8.01 (0.74)	15.03 (1.40)
FWTD/FWTC-3-9618	6.38 (0.59)	15.03 (1.40)
FWTD/FWTC-1-9620	10.83 (1.01)	18.15 (1.69)
FWTD/FWTC-3-9620	8.62 (0.80)	18.15 (1.69)
FWTD/FWTC-1-9624	13.64 (1.27)	21.27 (1.98)
FWTD/FWTC-3-9624	10.85 (1.01)	21.27 (1.98)

*Dimensions in parentheses are in square meters.

Venting Transom Window Opening and Area Specifications

Window Number	Clear Opening Sq. Ft./ (m ²)		Clear Opening in Full Open Position		Glass Area Sq. Ft./ (m ²)	Vent Sq. Ft./ (m ²)	Top of Subfloor to Top of Inside Sill Stop Inches/ (mm)	Overall Window Area Sq. Ft./ (m ²)
			Width Inches/ (mm)	Depth Inches/ (mm)				
ATV2114	0.79	(0.07)	19 3/16" (487)	5 7/8" (149)	1.04 (0.10)	0.79 (0.07)	69 1/2" (1765)	2.56 (0.24)
ATV2714	1.03	(0.10)	25 3/16" (640)	5 7/8" (149)	1.40 (0.13)	1.03 (0.10)	69 1/2" (1765)	3.19 (0.30)
ATV2914	1.11	(0.10)	27 3/16" (691)	5 7/8" (149)	1.52 (0.14)	1.11 (0.10)	69 1/2" (1765)	3.40 (0.32)
ATV3114	1.28	(0.12)	31 3/16" (792)	5 7/8" (149)	1.76 (0.16)	1.28 (0.12)	69 1/2" (1765)	3.83 (0.36)
ATV3314	1.36	(0.13)	33 3/16" (843)	5 7/8" (149)	1.88 (0.17)	1.36 (0.13)	69 1/2" (1765)	4.04 (0.38)
ATV4014	1.73	(0.16)	42 3/16" (1075)	5 7/8" (149)	2.43 (0.23)	1.73 (0.16)	69 1/2" (1765)	5.00 (0.46)
ATV5014	2.22	(0.21)	54 3/16" (1380)	5 7/8" (149)	3.14 (0.29)	2.22 (0.21)	69 1/2" (1765)	6.28 (0.58)
ATV5414	2.39	(0.22)	58 3/16" (1481)	5 7/8" (149)	3.38 (0.31)	2.39 (0.22)	69 1/2" (1765)	6.70 (0.62)
ATV6014	2.71	(0.25)	66 3/16" (1684)	5 7/8" (149)	3.86 (0.36)	2.71 (0.25)	69 1/2" (1765)	7.55 (0.70)
ATV2118	0.79	(0.07)	19 3/16" (487)	5 7/8" (149)	1.53 (0.14)	0.79 (0.07)	65 1/2" (1664)	3.23 (0.30)
ATV2718	1.03	(0.10)	25 3/16" (640)	5 7/8" (149)	2.05 (0.19)	1.03 (0.10)	65 1/2" (1664)	4.03 (0.37)
ATV2918	1.11	(0.10)	27 3/16" (691)	5 7/8" (149)	2.23 (0.21)	1.11 (0.10)	65 1/2" (1664)	4.29 (0.40)
ATV3118	1.28	(0.12)	31 3/16" (792)	5 7/8" (149)	2.58 (0.24)	1.28 (0.12)	65 1/2" (1664)	4.83 (0.45)
ATV3318	1.36	(0.13)	33 3/16" (843)	5 7/8" (149)	2.75 (0.26)	1.36 (0.13)	65 1/2" (1664)	5.10 (0.47)
ATV4018	1.73	(0.16)	42 3/16" (1075)	5 7/8" (149)	3.55 (0.33)	1.73 (0.16)	65 1/2" (1664)	6.32 (0.59)
ATV5018	2.22	(0.21)	54 3/16" (1380)	5 7/8" (149)	4.60 (0.43)	2.22 (0.21)	65 1/2" (1664)	7.92 (0.74)
ATV5418	2.39	(0.22)	58 3/16" (1481)	5 7/8" (149)	4.95 (0.46)	2.39 (0.22)	65 1/2" (1664)	8.46 (0.79)
ATV6018	2.71	(0.25)	66 3/16" (1684)	5 7/8" (149)	5.65 (0.52)	2.71 (0.25)	65 1/2" (1664)	9.53 (0.89)
ATV2120	0.79	(0.07)	19 3/16" (487)	5 7/8" (149)	2.01 (0.19)	0.79 (0.07)	61 1/2" (1562)	3.90 (0.36)
ATV2720	1.03	(0.10)	25 3/16" (640)	5 7/8" (149)	2.71 (0.25)	1.03 (0.10)	61 1/2" (1562)	4.86 (0.45)
ATV2920	1.11	(0.10)	27 3/16" (691)	5 7/8" (149)	2.94 (0.27)	1.11 (0.10)	61 1/2" (1562)	5.19 (0.48)
ATV3120	1.28	(0.12)	31 3/16" (792)	5 7/8" (149)	3.40 (0.32)	1.28 (0.12)	61 1/2" (1562)	5.83 (0.54)
ATV3320	1.36	(0.13)	33 3/16" (843)	5 7/8" (149)	3.63 (0.34)	1.36 (0.13)	61 1/2" (1562)	6.16 (0.57)
ATV4020	1.73	(0.16)	42 3/16" (1075)	5 7/8" (149)	4.68 (0.44)	1.73 (0.16)	61 1/2" (1562)	7.63 (0.71)
ATV5020	2.22	(0.21)	54 3/16" (1380)	5 7/8" (149)	6.06 (0.56)	2.22 (0.21)	61 1/2" (1562)	9.57 (0.89)
ATV5420	2.39	(0.22)	58 3/16" (1481)	5 7/8" (149)	6.53 (0.61)	2.39 (0.22)	61 1/2" (1562)	10.21 (0.95)
ATV6020	2.71	(0.25)	66 3/16" (1684)	5 7/8" (149)	7.45 (0.69)	2.71 (0.25)	61 1/2" (1562)	1.07 (0.10)
ATV2124	0.79	(0.07)	19 3/16" (487)	5 7/8" (149)	2.50 (0.23)	0.79 (0.07)	57 1/2" (1461)	4.57 (0.42)
ATV2724	1.03	(0.10)	25 3/16" (640)	5 7/8" (149)	3.36 (0.31)	1.03 (0.10)	57 1/2" (1461)	5.70 (0.53)
ATV2924	1.11	(0.10)	27 3/16" (691)	5 7/8" (149)	3.64 (0.34)	1.11 (0.10)	57 1/2" (1461)	6.08 (0.56)
ATV3124	1.28	(0.12)	31 3/16" (792)	5 7/8" (149)	4.22 (0.39)	1.28 (0.12)	57 1/2" (1461)	6.84 (0.64)
ATV3324	1.36	(0.13)	33 3/16" (843)	5 7/8" (149)	4.50 (0.42)	1.36 (0.13)	57 1/2" (1461)	7.23 (0.67)
ATV4024	1.73	(0.16)	42 3/16" (1075)	5 7/8" (149)	5.81 (0.54)	1.73 (0.16)	57 1/2" (1461)	8.94 (0.83)
ATV5024	2.22	(0.21)	54 3/16" (1380)	5 7/8" (149)	7.53 (0.70)	2.22 (0.21)	57 1/2" (1461)	11.21 (1.04)
ATV5424	2.39	(0.22)	58 3/16" (1481)	5 7/8" (149)	8.10 (0.75)	2.39 (0.22)	57 1/2" (1461)	11.97 (1.11)
ATV6024	2.71	(0.25)	66 3/16" (1684)	5 7/8" (149)	9.24 (0.86)	2.71 (0.25)	57 1/2" (1461)	13.49 (1.25)

*"Top of Subfloor to Top of Inside Sill Stop" is calculated based upon a structural header height of 6'-10 1/2" (2096).

*Dimensions in parentheses are in millimeters or square meters.

PATIO DOOR SIDELIGHTS & TRANSOMS

Grille Patterns

	Diamond	Prairie A	Colonial		Prairie A	Colonial
Patio Door Transoms Traditional				Patio Door Transoms Contemporary		
Patio Door Sidelights Traditional Panels				Patio Door Sidelights Contemporary Panels		

Number of lights and overall pattern varies with transom or sidelight size. Patterns may not be available in all configuration or sizes. Specified equal light patterns are also available. Custom patterns are only available for sidelights with traditional panels. For venting transom window grille patterns, see page 58. For more grille options, see page 19 or visit andersenwindows.com/grilles.

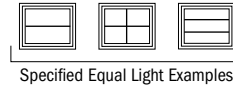

Specified Equal Light Examples

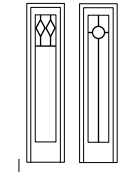

Custom Examples

Direct-Set Patio Door Transom and Sidelight Transom Details - Traditional

Scale 1 1/2" (38) = 1'-0" (305) - 1:8

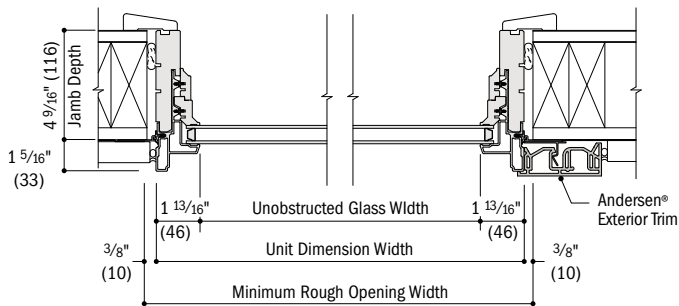

Horizontal Section
Transom and Sidelight Transom, Traditional

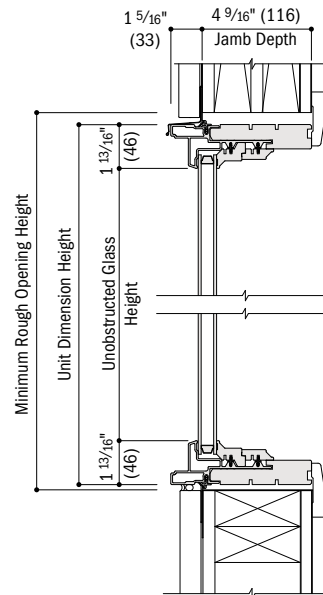

Vertical Section
Transom and Sidelight Transom, Traditional

- 4 9/16" (116) jamb depth measurement is from back side of installation flange.
- Light-colored areas are parts included with sidelights and/or transoms. Dark-colored areas are additional Andersen® parts required to complete assembly as shown.
- Dimensions in parentheses are in millimeters.
- **Minimum rough openings may need to be increased to allow for use of building wraps, flashing, sill panning, brackets, fasteners or other items. See installation information on pages 226-227.**
- Details are for illustration only and are not intended to represent product installation methods or materials. Refer to product installation instructions at andersenwindows.com.

Sash-Set Patio Door Transom, Sidelight Transom and Sidelight Details - Traditional

Scale 1 1/2" (38) = 1'-0" (305) - 1:8

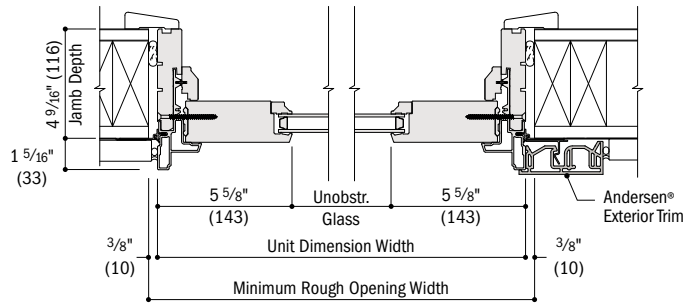

Horizontal Section
Transom, Traditional

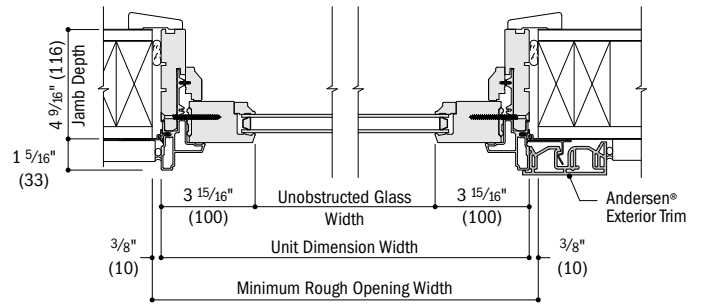

Horizontal Section
Sidelight Transom and Sidelight, Traditional

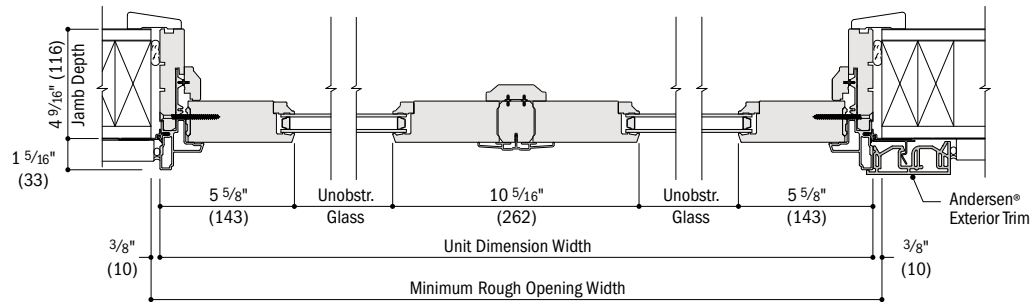

Horizontal Section
Twin Transom, Traditional

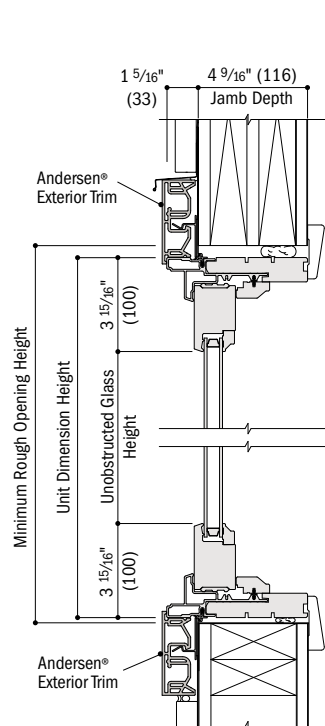

Vertical Section
Transom and Sidelight Transom, Traditional

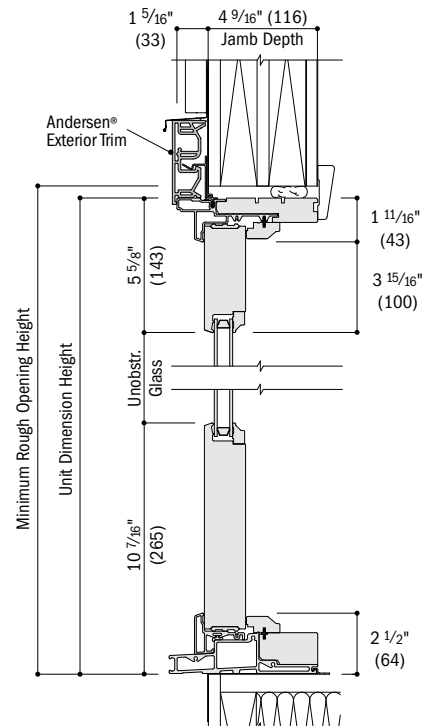

Vertical Section
Sidelight, Traditional

See pages 168-171 for joining details.

- 4 9/16" (116) jamb depth measurement is from back side of installation flange.
- Light-colored areas are parts included with sidelights and/or transoms. Dark-colored areas are additional Andersen® parts required to complete assembly as shown.
- Dimensions in parentheses are in millimeters.
- **Minimum rough openings may need to be increased to allow for use of building wraps, flashing, sill panning, brackets, fasteners or other items. See installation information on pages 226-227.**

• Details are for illustration only and are not intended to represent product installation methods or materials. Refer to product installation instructions at andersenwindows.com.

PATIO DOOR SIDELIGHTS & TRANSOMS

Venting Transom Window Details - Traditional

Scale 1 1/2" (38) = 1'-0" (305) - 1:8

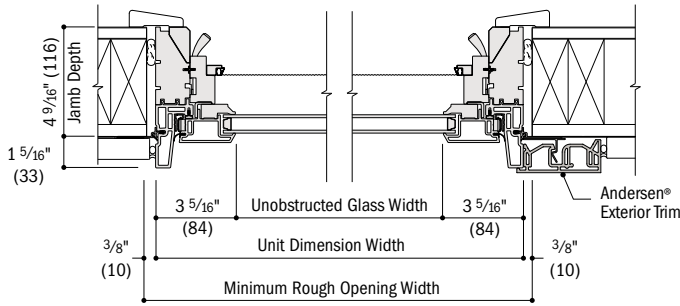

Horizontal Section
Venting Transom Window, Traditional

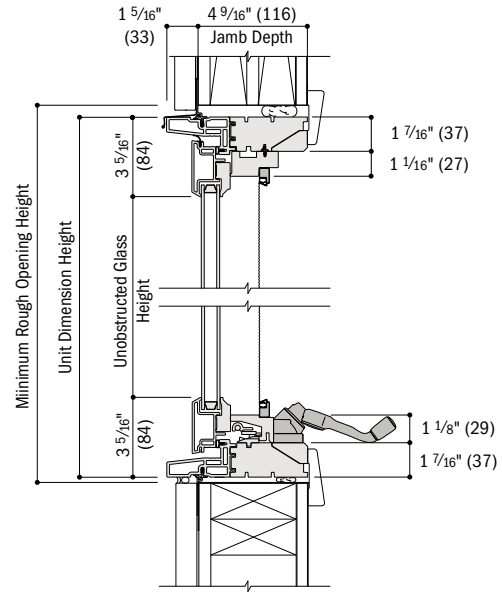

Vertical Section
Venting Transom Window, Traditional

Direct-Set Patio Door Transom and Sidelight Transom Details - Contemporary

Scale 1 1/2" (38) = 1'-0" (305) - 1:8

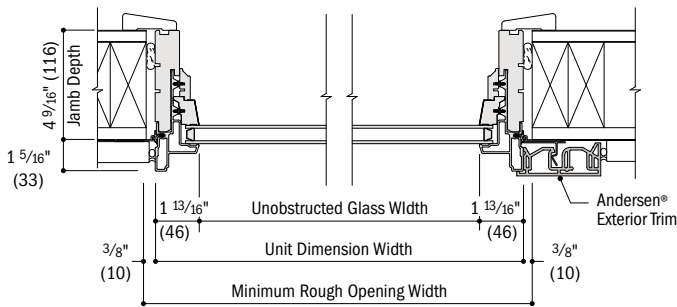

Horizontal Section
Transom and Sidelight Transom, Contemporary

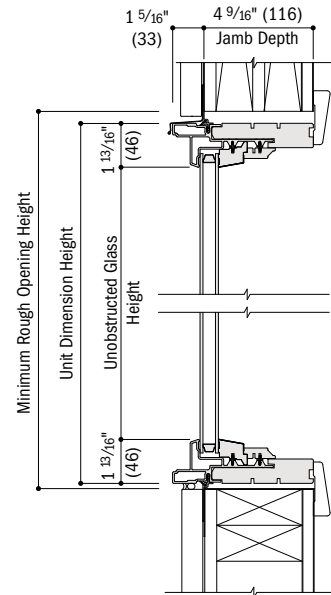

Vertical Section
Transom and Sidelight Transoms

- 4 9/16" (116) jamb depth measurement is from back side of installation flange.
- Light-colored areas are parts included with sidelights and/or transoms. Dark-colored areas are additional Andersen® parts required to complete assembly as shown.
- Dimensions in parentheses are in millimeters.
- **Minimum rough openings may need to be increased to allow for use of building wraps, flashing, sill panning, brackets, fasteners or other items. See installation information on pages 226-227.**
- Details are for illustration only and are not intended to represent product installation methods or materials. Refer to product installation instructions at andersenwindows.com.

Sash-Set Patio Door Transom, Sidelight Transom and Sidelight Details – Contemporary

Scale 1 1/2" (38) = 1'-0" (305) – 1:8

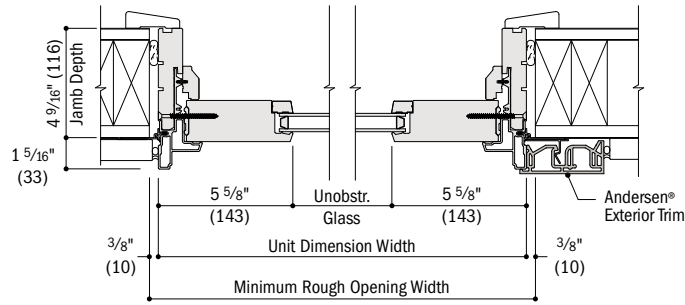

Horizontal Section
Transom, Contemporary

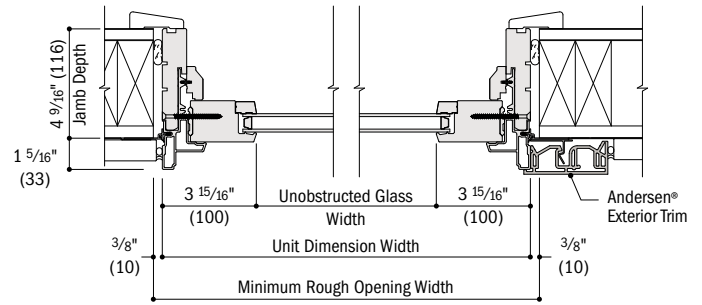

Horizontal Section
Transom and Sidelight Transom, Contemporary

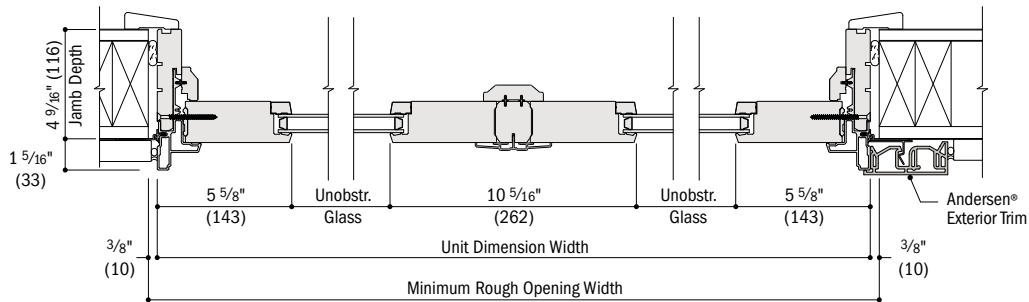

Horizontal Section
Twin Transom, Contemporary

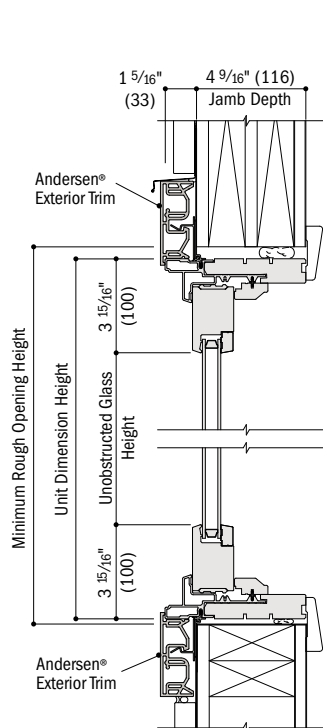

Vertical Section
Transom and Sidelight Transom, Contemporary

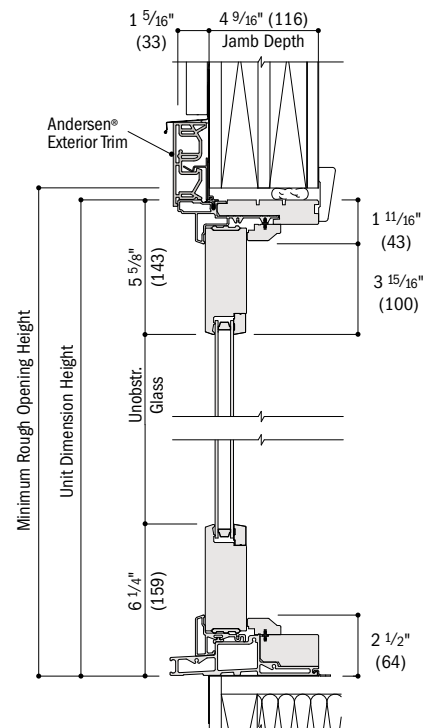

Vertical Section
Sidelight, Contemporary

See pages 168-171 for joining details.

- 4 9/16" (116) jamb depth measurement is from back side of installation flange.
- Light-colored areas are parts included with sidelights and/or transoms. Dark-colored areas are additional Andersen® parts required to complete assembly as shown.
- Dimensions in parentheses are in millimeters.
- **Minimum rough openings may need to be increased to allow for use of building wraps, flashing, sill panning, brackets, fasteners or other items. See installation information on pages 226-227.**
- Details are for illustration only and are not intended to represent product installation methods or materials. Refer to product installation instructions at andersenwindows.com.

PATIO DOORS

Vertical (ribbon) Easy Connect Fiberglass Joining Details

Scale 1 1/2" (38) = 1'-0" (305) – 1:8

Patio doors, sidelights and transoms can be joined using 3/4" (19) x 5 3/4" (146) fiberglass joining material for 4 9/16" (116) base jamb depths. 3/4" (19) x 7 3/4" (197) fiberglass joining material is used for higher performance and is required for hinged inswing patio doors with 6 9/16" (167) base jamb depths.

Products with traditional option shown. Details also apply to products with contemporary option. **Do not join inswing or outswing doors hinge jamb to hinge jamb.**

Hinged Inswing Patio Doors

Overall Door-Door or Door-Sidelight Dimension Width – Sum of individual door-door or door-sidelight widths plus 3/4" (19) per join.

Overall Minimum Rough Opening Width – Overall dimension width plus 3/4" (19).

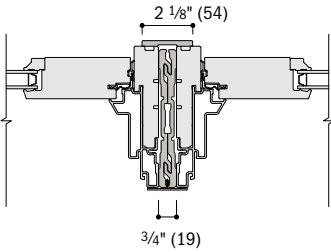

Stationary Jamb to Stationary Jamb
4 9/16" (116) Base Jamb Depth

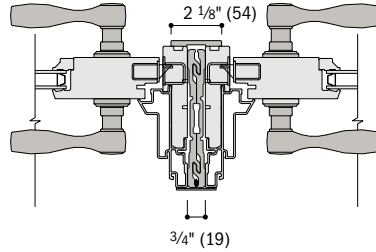

Latch Jamb to Latch Jamb
4 9/16" (116) Base Jamb Depth

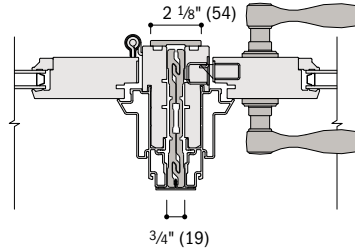

Hinge Jamb to Latch Jamb
4 9/16" (116) Base Jamb Depth

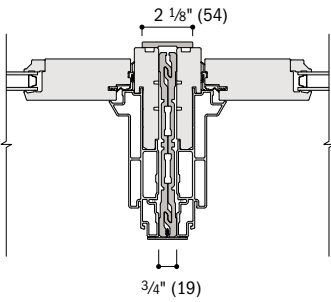

Stationary Jamb to Stationary Jamb
6 9/16" (167) Base Jamb Depth

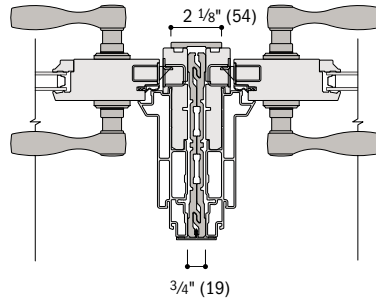

Latch Jamb to Latch Jamb
6 9/16" (167) Base Jamb Depth

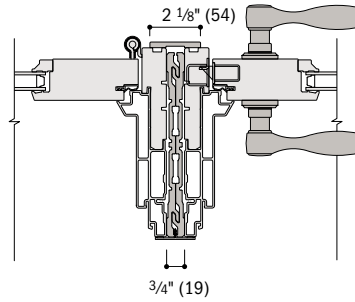

Hinge Jamb to Latch Jamb
6 9/16" (167) Base Jamb Depth

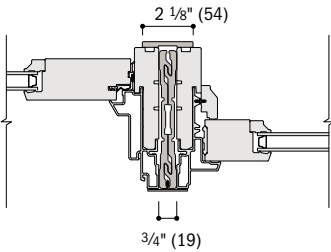

Stationary Jamb to Sidelight
4 9/16" (116) Base Jamb Depth

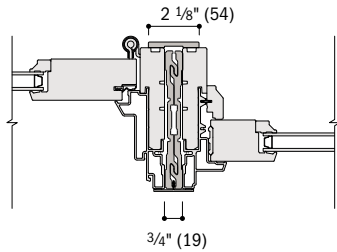

Hinge Jamb to Sidelight
4 9/16" (116) Base Jamb Depth

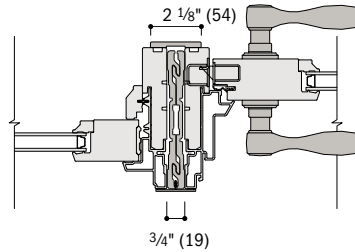

Sidelight to Latch Jamb
4 9/16" (116) Base Jamb Depth

Hinged Outswing Patio Doors

Overall Door-Door or Door-Sidelight Dimension Width – Sum of individual door-door or door-sidelight widths plus 3/4" (19) per join.

Overall Minimum Rough Opening Width – Overall dimension width plus 3/4" (19).

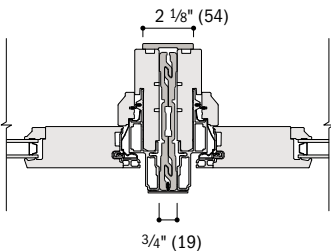

Stationary Door to Stationary Door

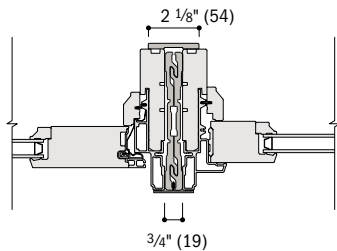

Stationary Door to Sidelight

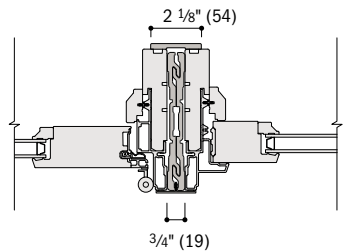

Hinge Jamb to Sidelight

- Light-colored areas are parts included with patio doors, sidelights and/or transoms. Dark-colored areas are additional Andersen® parts required to complete assembly as shown.
- Dimensions in parentheses are in millimeters.
- **Minimum rough openings may need to be increased to allow for use of building wraps, flashing, sill panning, brackets, fasteners or other items. See installation information on pages 226-227.**
- Details are for illustration only and are not intended to represent product installation methods or materials. Refer to product installation instructions at andersenwindows.com.
- Structural performance of any combination is only as high as the lowest structural performance of any individual product or join in the combination.

Vertical (ribbon) Easy Connect Fiberglass Joining Details

Scale 1 1/2" (38) = 1'-0" (305) – 1:8

Gliding Patio Doors

Overall Door-Door or Door-Sidelight Dimension Width – Sum of individual door-door or door-sidelight widths plus 3/4" (19) per join.

Overall Minimum Rough Opening Width – Overall dimension width plus 3/4" (19).

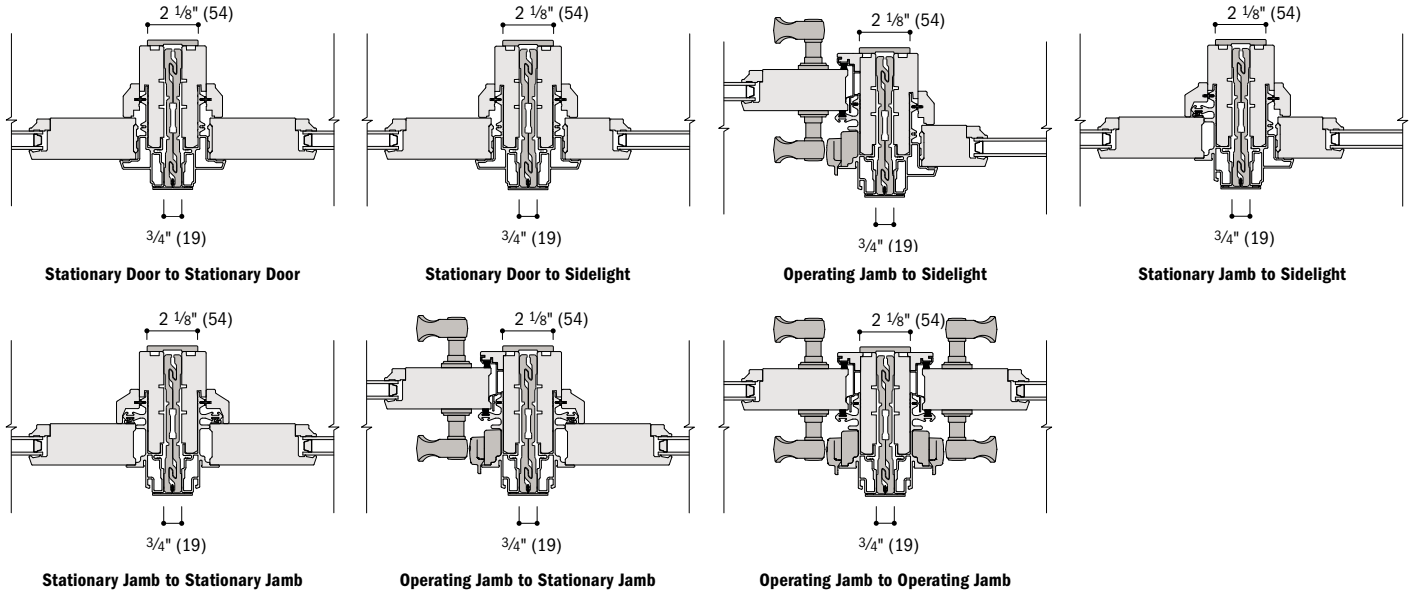

Patio Door Transoms and Sidelight Transoms

Overall "Transom-Transom" or "Transom-Sidelight Transom" Dimension Width – Sum of individual "transom-transom" or "transom-sidelight transom" widths plus 3/4" (19) per join.

Overall Minimum Rough Opening Width – Overall dimension width plus 3/4" (19).

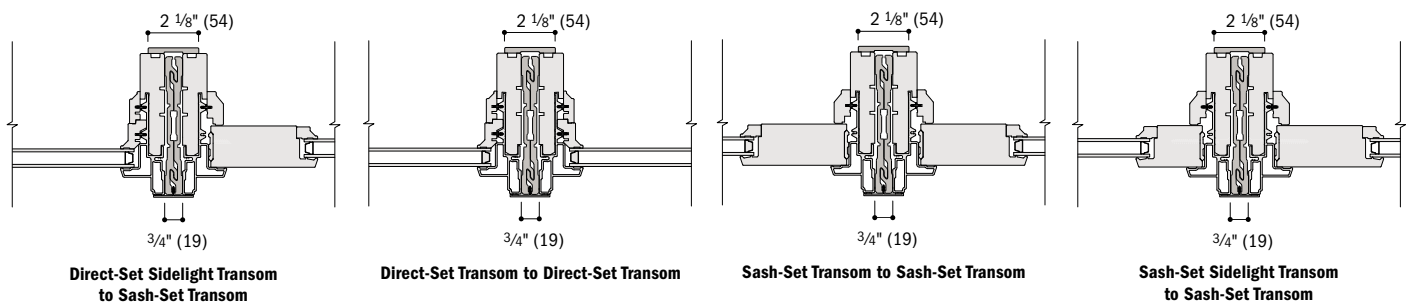

Venting Transom Windows

Overall "Venting Transom Window" Dimension Width – Sum of individual "venting transom window" widths plus 3/4" (19) per join.

Overall Minimum Rough Opening Width – Overall dimension width plus 3/4" (19).

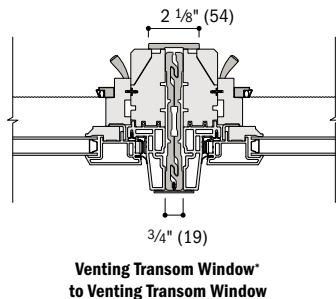

For more information on joining, refer to the combination designs section starting on page 196.

- Light-colored areas are parts included with doors, sidelights and/or transoms. Dark-colored areas are additional Andersen® parts required to complete assembly as shown.
- Dimensions in parentheses are in millimeters.
- **Minimum rough openings may need to be increased to allow for use of building wraps, flashing, sill panning, brackets, fasteners or other items. See installation information on pages 226-227.**
- Details are for illustration only and are not intended to represent product installation methods or materials. Refer to product installation instructions at andersenwindows.com.
- Structural performance of any combination is only as high as the lowest structural performance of any individual product or join in the combination.
- *Not available with contemporary option.

PATIO DOORS

Transom Options

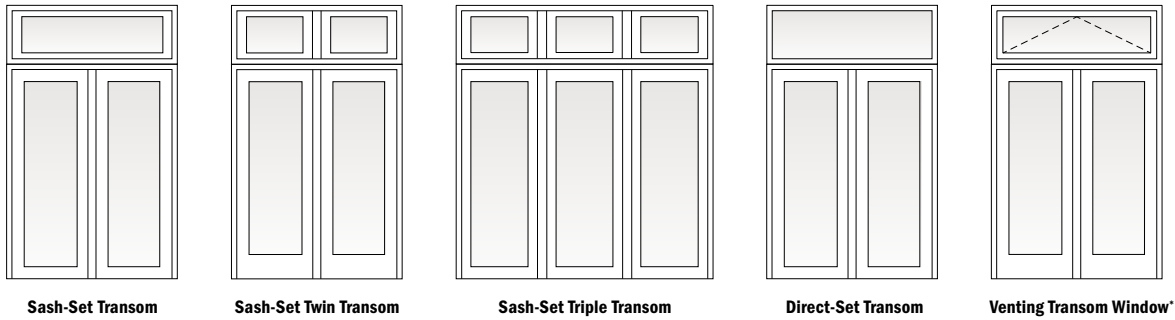

Horizontal (stack) Easy Connect Fiberglass Joining Details

Scale 1 1/2" (38) = 1'-0" (305) – 1:8

Products with traditional option shown. Details also apply to products with contemporary option. Venting transoms windows are only available in traditional option.

A structural header is required to separate patio door transoms and transom windows from four-panel gliding patio doors.

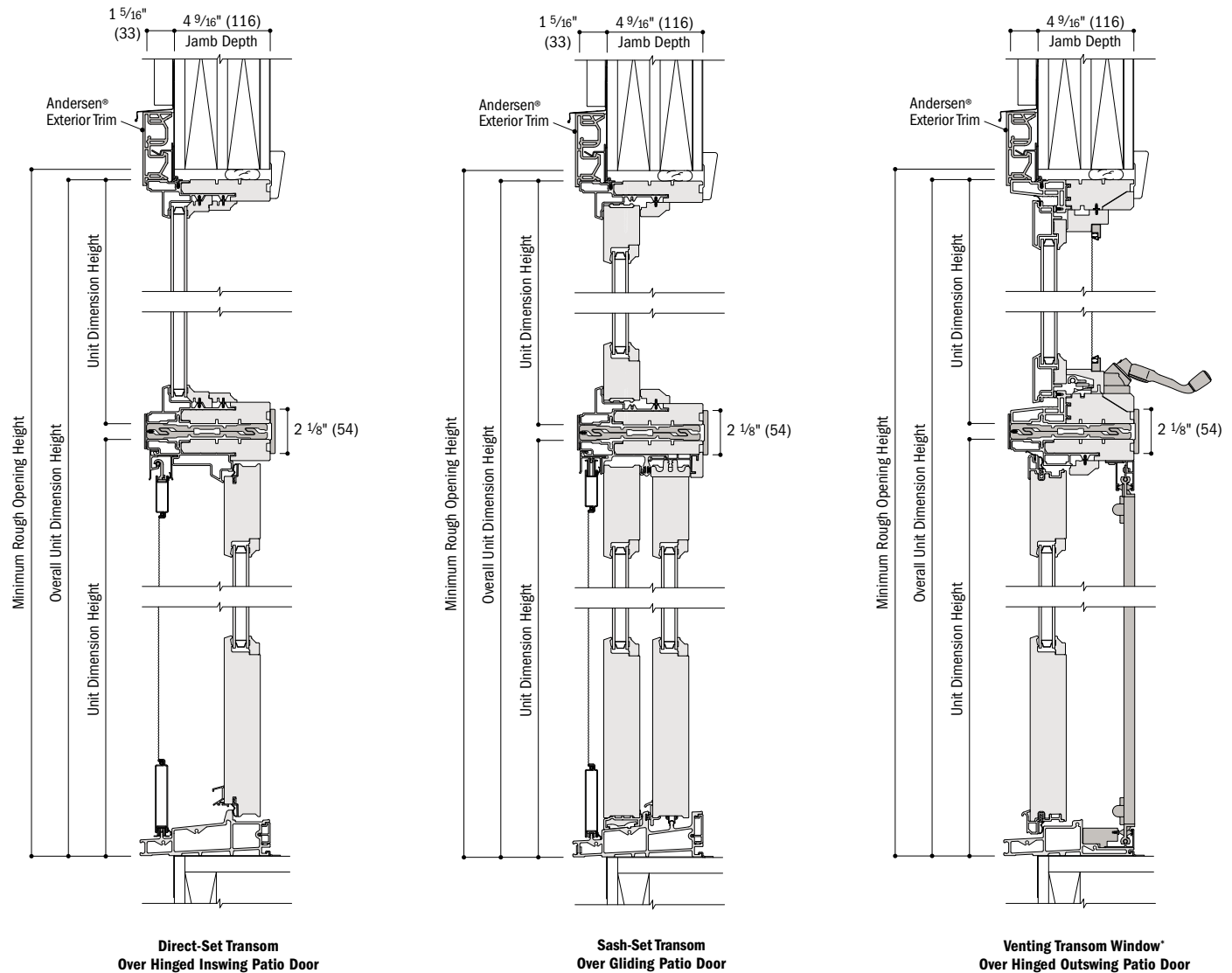

- Light-colored areas are parts included with doors, sidelights and/or transoms. Dark-colored areas are additional Andersen® parts required to complete assembly as shown.
- Dimensions in parentheses are in millimeters.
- **Minimum rough openings may need to be increased to allow for use of building wraps, flashing, sill panning, brackets, fasteners or other items. See installation information on pages 226-227.**
- Details are for illustration only and are not intended to represent product installation methods or materials. Refer to product installation instructions at andersenwindows.com.
- Structural performance of any combination is only as high as the lowest structural performance of any individual product or join in the combination.
- *Join venting transom windows over doors with traditional option only. Venting transom windows are not available with contemporary option.

Horizontal (stack) Easy Connect Fiberglass Joining Details

Scale 1 1/2" (38) = 1'-0" (305) – 1:8

Overall Transom/Door Dimension Height – Sum of individual transom/door heights plus 3/4" (19) per join.

Overall Sidelight Transom/Sidelight Dimension Height – Sum of individual sidelight transom/sidelight heights plus 3/4" (19) per join.

Overall Minimum Rough Opening Height – Overall dimension height plus 1/2" (13).

Products with traditional option shown. Details also apply to products with contemporary option. Venting transoms windows are only available in traditional option.

A structural header is required to separate patio door transoms and transom windows from four-panel gliding patio doors.

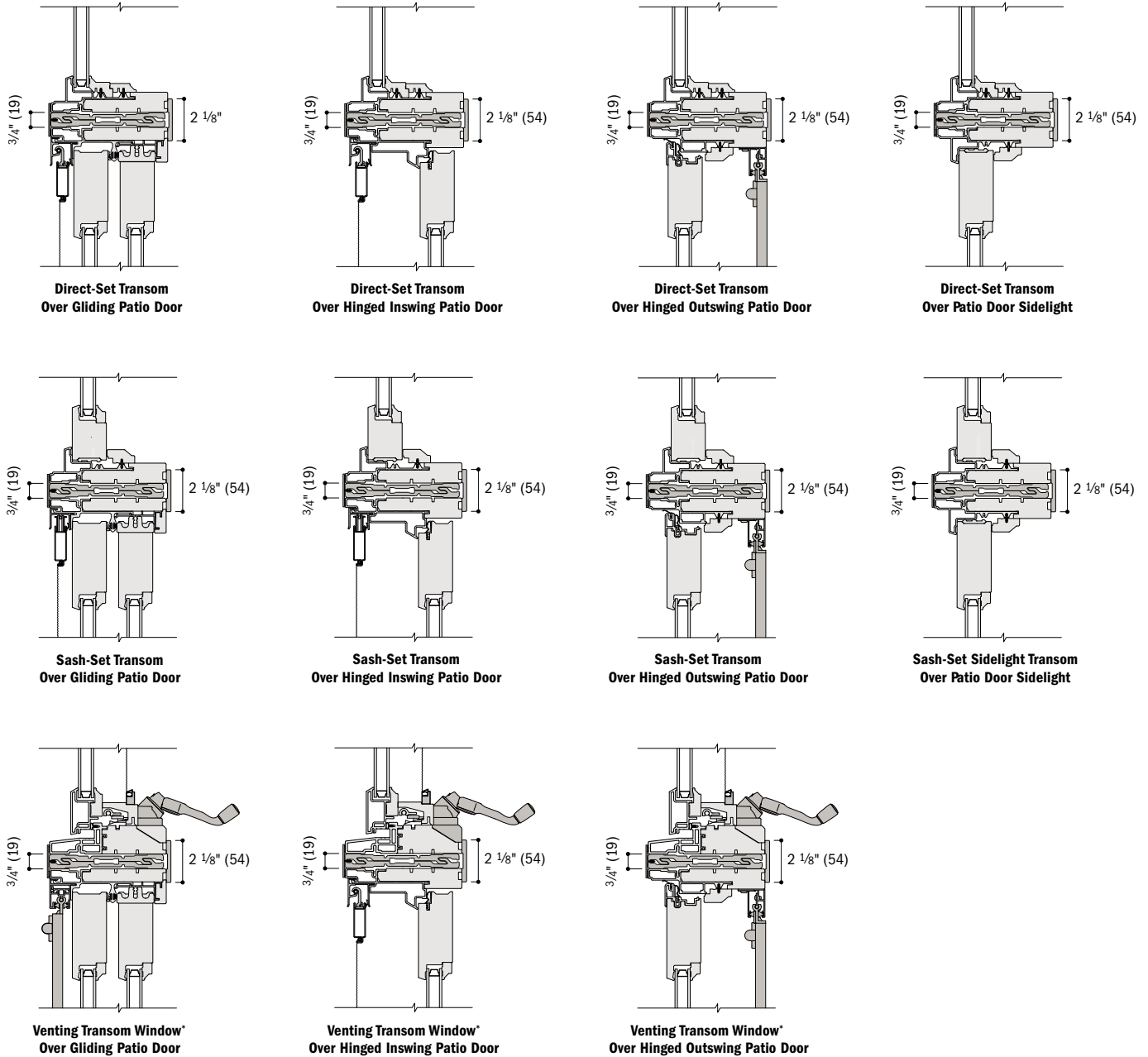

For specialty windows over patio doors, see page 112. For more information on joining, refer to the combination designs section starting on page 196.

- Light-colored areas are parts included with doors, sidelights and/or transoms. Dark-colored areas are additional Andersen® parts required to complete assembly as shown.
- Dimensions in parentheses are in millimeters.
- **Minimum rough openings may need to be increased to allow for use of building wraps, flashing, sill panning, brackets, fasteners or other items. See installation information on pages 226-227.**
- Details are for illustration only and are not intended to represent product installation methods or materials. Refer to product installation instructions at andersenwindows.com.
- Structural performance of any combination is only as high as the lowest structural performance of any individual product or join in the combination.
- *Join venting transom windows over doors with traditional option only. Venting transom windows are not available with contemporary option.

PATIO DOORS

Custom Sizes and Specification Formulas



A-Series custom-size patio doors, sidelights and transoms are available in 1/8" (3) increments between minimum and maximum widths and heights. Some restrictions apply. Contact your Andersen supplier.

Gliding Patio Doors

Dual-Pane & Triple-Pane

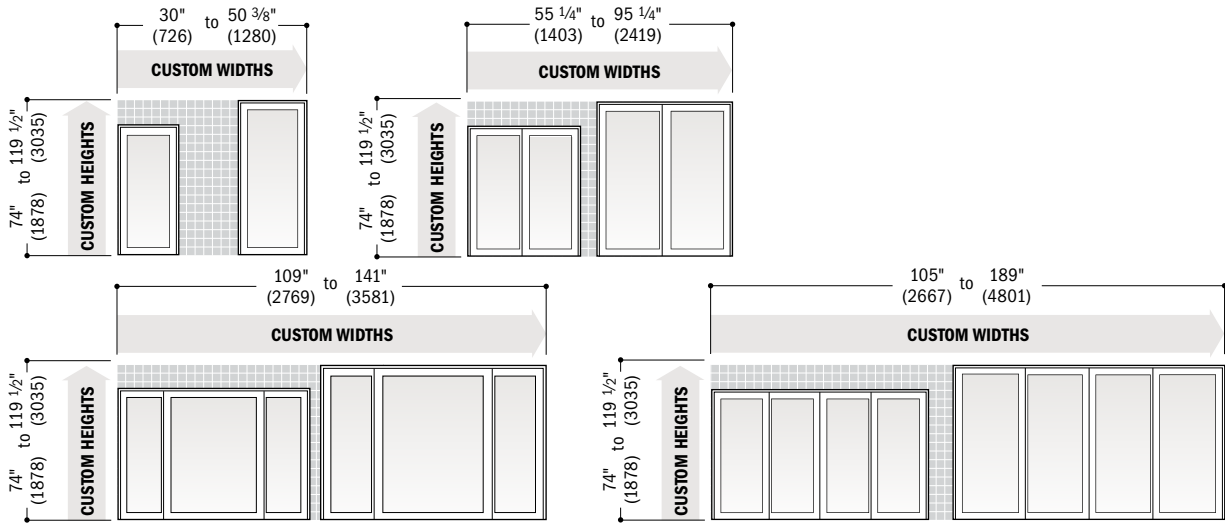

Clear Opening	Two-Panel	Minimum R.O.	Single-Panel	Unobst. Glass	Traditional Single-Panel
<p>Patio Doors Traditional or Contemporary Panels</p>	<p>Width = (door width ÷ 2) - 8.368" (213)</p> <p>Height = door height - 3.927" (98)</p>	<p>Patio Doors Traditional or Contemporary Panels</p>	<p>Width = door width + 3/4" (19)</p> <p>Height = door height + 1/2" (13)</p>	<p>Patio Doors Traditional Panels</p>	<p>Width = door width - 11.22" (285)</p> <p>Height = door height - 16.06" (408)</p>
	<p>Three-Panel, one panel open</p> <p>Width = (door width ÷ 4) - 7.993" (203)</p> <p>Height = door height - 3.927" (100)</p>		<p>Two-Panel</p> <p>Width = door width + 3/4" (19)</p> <p>Height = door height + 1/2" (13)</p>		<p>Traditional Two-Panel</p> <p>Width = door width - 17.00" (432)</p> <p>Height = door height - 16.06" (408)</p>
	<p>Four-Panel, two panels open</p> <p>Width = (door width ÷ 2) - 15.458" (393)</p> <p>Height = door height - 3.927" (100)</p>		<p>Three-Panel</p> <p>Width = door width + 1" (25)</p> <p>Height = door height + 1/2" (13)</p>		<p>Traditional Three-Panel</p> <p>Width = door width - 22.78" (579)</p> <p>Height = door height - 16.06" (408)</p>
			<p>Four-Panel</p> <p>Width = door width + 1" (25)</p> <p>Height = door height + 1/2" (13)</p>		<p>Traditional Four-Panel</p> <p>Width = door width - 11.22" (285)</p> <p>Height = door height - 16.06" (408)</p>
				<p>Patio Doors Contemporary Panels</p>	<p>Contemporary Single-Panel</p> <p>Width = door width - 11.22" (285)</p> <p>Height = door height - 11.90" (302)</p>
					<p>Contemporary Two-Panel</p> <p>Width = door width - 17.00" (432)</p> <p>Height = door height - 11.90" (302)</p>
					<p>Contemporary Three-Panel</p> <p>Width = door width - 22.78" (579)</p> <p>Height = door height - 11.90" (302)</p>
					<p>Contemporary Four-Panel</p> <p>Width = door width - 11.22" (285)</p> <p>Height = door height - 11.90" (302)</p>

• Dimensions in parentheses are in millimeters.

• **Clear Opening** formulas provide dimensions for determining area available for egress. **Vent Opening** formulas provide dimensions for determining area available for passage of air. **Minimum R.O.** (minimum rough opening) formulas provide minimum rough opening width and height dimensions. **Unobst. Glass** (unobstructed glass) formulas provide dimensions for determining area available for passage of light.

• Custom minimum and maximum dimensions apply to patio doors with either traditional and contemporary panels. Contemporary panels shown.

Hinged Inswing Patio Doors

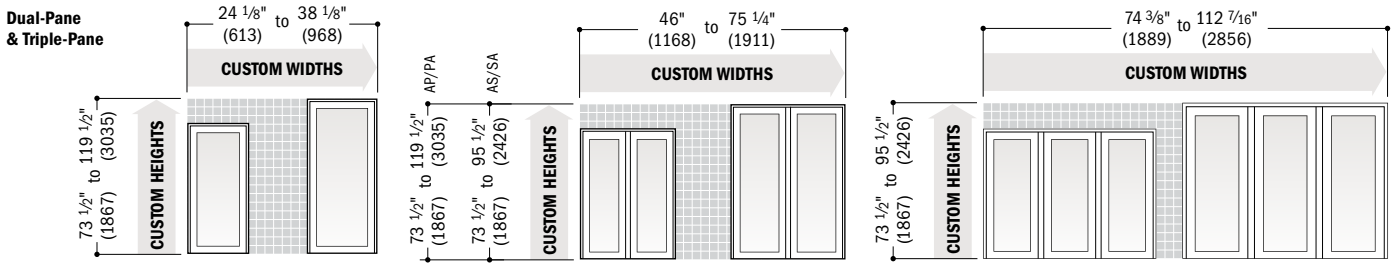

<p>Clear Opening</p> <p>Patio Doors Traditional or Contemporary Panels</p>	<p>Height = door height - 4.232" (107)</p> <p>Single-Panel Width = door width - 5.799" (147)</p> <p>Two-Panel, two panels open Width = door width - 7.477" (190)</p> <p>Two-Panel, one panel open Width = (door width - 8.992" (228)) + 2</p> <p>Three-Panel, one panel open Width = (door width - 12.072" (307)) + 3</p>	<p>Minimum R.O.</p> <p>Patio Doors Traditional or Contemporary Panels</p>	<p>Single-Panel Width = door width + 3/4" (19) Height = door height + 1/2" (13)</p> <p>Two-Panel Width = door width + 3/4" (19) Height = door height + 1/2" (13)</p> <p>Three-Panel Width = door width + 3/4" (19) Height = door height + 1/2" (13)</p>	<p>Unobst. Glass</p> <p>Patio Doors Traditional Panels</p> <p>Patio Doors Contemporary Panels</p>	<p>Traditional Single-Panel Width = door width - 11.22" (285) Height = door height - 16.06" (408)</p> <p>Traditional Two-Panel Width = door width - 21.50" (546) Height = door height - 16.06" (408)</p> <p>Traditional Three-Panel Width = door width - 31.784" (807) Height = door height - 16.06" (408)</p> <p>Contemporary Single-Panel Width = door width - 11.22" (285) Height = door height - 11.90" (302)</p> <p>Contemporary Two-Panel Width = door width - 21.50" (546) Height = door height - 11.90" (302)</p> <p>Contemporary Three-Panel Width = door width - 31.784" (807) Height = door height - 11.90" (302)</p>
	<p>Height = door height - 3.418" (87)</p> <p>Single-Panel Width = door width - 5.04" (128)</p> <p>Two-Panel, two panels open Width = door width - 6.69" (170)</p> <p>Two-Panel, one panel open Width = (door width - 9.959" (253)) + 2</p>		<p>Single-Panel Width = door width + 3/4" (19) Height = door height + 1/2" (13)</p> <p>Two-Panel Width = door width + 3/4" (19) Height = door height + 1/2" (13)</p>		<p>Traditional Single-Panel Width = door width - 11.22" (285) Height = door height - 16.06" (408)</p> <p>Traditional Two-Panel Width = door width - 21.50" (546) Height = door height - 16.06" (408)</p> <p>Contemporary Single-Panel Width = door width - 11.22" (285) Height = door height - 11.90" (302)</p> <p>Contemporary Two-Panel Width = door width - 21.50" (546) Height = door height - 11.90" (302)</p>

Hinged Outswing Patio Doors

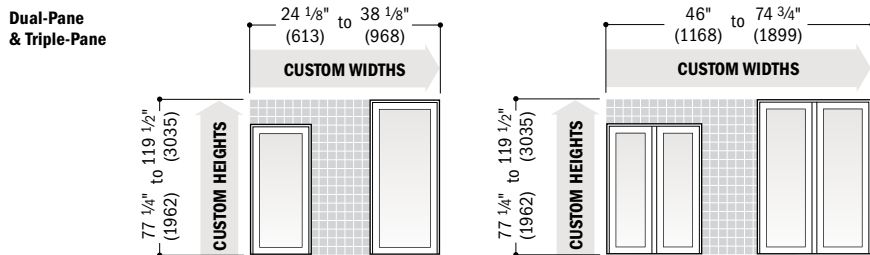

<p>Clear Opening</p> <p>Patio Doors Traditional or Contemporary Panels</p>	<p>Height = door height - 3.418" (87)</p> <p>Single-Panel Width = door width - 5.04" (128)</p> <p>Two-Panel, two panels open Width = door width - 6.69" (170)</p> <p>Two-Panel, one panel open Width = (door width - 9.959" (253)) + 2</p>	<p>Minimum R.O.</p> <p>Patio Doors Traditional or Contemporary Panels</p>	<p>Single-Panel Width = door width + 3/4" (19) Height = door height + 1/2" (13)</p> <p>Two-Panel Width = door width + 3/4" (19) Height = door height + 1/2" (13)</p>	<p>Unobst. Glass</p> <p>Patio Doors Traditional Panels</p> <p>Patio Doors Contemporary Panels</p>	<p>Traditional Single-Panel Width = door width - 11.22" (285) Height = door height - 16.06" (408)</p> <p>Traditional Two-Panel Width = door width - 21.50" (546) Height = door height - 16.06" (408)</p> <p>Contemporary Single-Panel Width = door width - 11.22" (285) Height = door height - 11.90" (302)</p> <p>Contemporary Two-Panel Width = door width - 21.50" (546) Height = door height - 11.90" (302)</p>
	<p>Height = door height - 3.418" (87)</p> <p>Single-Panel Width = door width - 5.04" (128)</p> <p>Two-Panel, two panels open Width = door width - 6.69" (170)</p> <p>Two-Panel, one panel open Width = (door width - 9.959" (253)) + 2</p>		<p>Single-Panel Width = door width + 3/4" (19) Height = door height + 1/2" (13)</p> <p>Two-Panel Width = door width + 3/4" (19) Height = door height + 1/2" (13)</p>		<p>Traditional Single-Panel Width = door width - 11.22" (285) Height = door height - 16.06" (408)</p> <p>Traditional Two-Panel Width = door width - 21.50" (546) Height = door height - 16.06" (408)</p> <p>Contemporary Single-Panel Width = door width - 11.22" (285) Height = door height - 11.90" (302)</p> <p>Contemporary Two-Panel Width = door width - 21.50" (546) Height = door height - 11.90" (302)</p>

• Dimensions in parentheses are in millimeters.
 • **Clear Opening** formulas provide dimensions for determining area available for egress. **Vent Opening** formulas provide dimensions for determining area available for passage of air. **Minimum R.O.** (minimum rough opening) formulas provide minimum rough opening width and height dimensions. **Unobst. Glass** (unobstructed glass) formulas provide dimensions for determining area available for passage of light.
 • Custom minimum and maximum dimensions apply to patio doors with either traditional and contemporary panels. Contemporary panels shown.

PATIO DOORS

Patio Door Sidelights

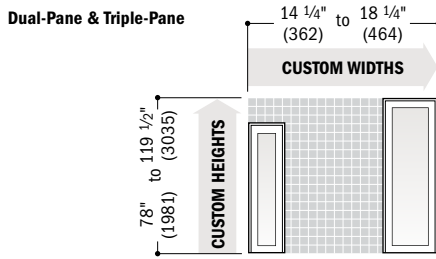

Minimum R.O.	Sidelight	Unobst. Glass	Traditional Panel
<p>Patio Door Sidelights Traditional or Contemporary Panels</p>	<p>Width = sidelight width + 3/4" (19) Height = sidelight height + 1/2" (13)</p>	<p>Patio Door Sidelights Traditional Panels</p> <p>Patio Door Sidelights Contemporary Panels</p>	<p>Width = sidelight width - 7.84" (199) Height = sidelight height - 16.06" (408)</p>
			<p>Contemporary Panel Width = sidelight width - 7.84" (199) Height = sidelight height - 11.90" (302)</p>

Patio Door Sidelight Transoms

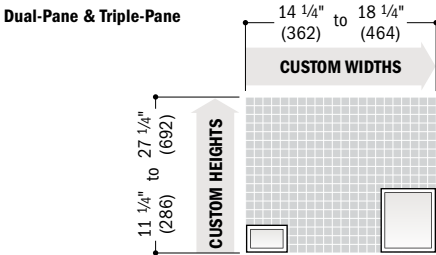

Minimum R.O.	Sash-Set Sidelight Transom	Unobst. Glass	Sash-Set Sidelight Transom
<p>Patio Door Transom Traditional or Contemporary</p>	<p>Width = transom width + 3/4" (19) Height = transom height + 3/4" (19)</p> <p>Direct-Set Sidelight Transom Width = transom width + 3/4" (19) Height = transom height + 3/4" (19)</p>	<p>Patio Door Transom Traditional or Contemporary</p>	<p>Width = transom width - 7.84" (199) Height = transom height - 7.84" (199)</p>
			<p>Direct-Set Sidelight Transom Width = transom width - 3.66" (93) Height = transom height - 3.66" (93)</p>

* Dimensions in parentheses are in millimeters.

* **Minimum R.O.** (minimum rough opening) formulas provide minimum rough opening width and height dimensions. **Unobst. Glass** (unobstructed glass) formulas provide dimensions for determining area available for passage of light.

* Custom minimum and maximum dimensions apply to patio door sidelights with either traditional and contemporary panels. Contemporary panels shown.

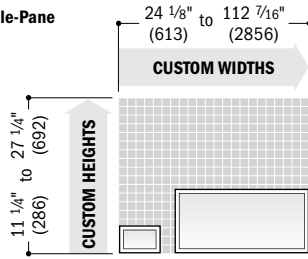
Patio Door Transoms
Dual-Pane & Triple-Pane

For custom sizes and specification formulas for venting transom windows, see page 69.

Minimum R.O.	Direct-Set Transom	Unobst. Glass	Direct-Set Transom
 Patio Door Sidelight Transom Traditional or Contemporary	Width = transom width + 3/4" (19) Height = transom height + 3/4" (19)	 Patio Door Sidelight Transom Traditional or Contemporary	Width = transom width - 3.66" (93) Height = transom height - 3.66" (93)
	Sash-Set Transom Width = transom width + 3/4" (19) Height = transom height + 3/4" (19)		Sash-Set Transom Width = transom width - 11.22" (285) Height = transom height - 7.84" (199)

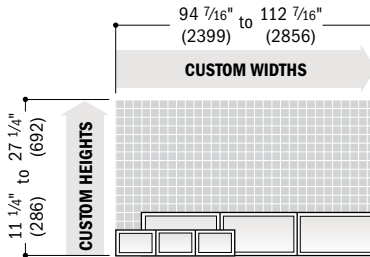
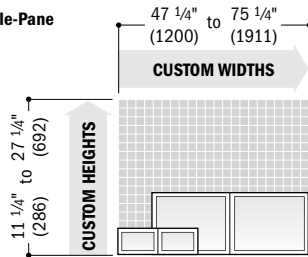
Patio Door Twin and Triple Transoms
Dual-Pane & Triple-Pane

Minimum R.O.	Twin	Unobst. Glass	Twin
 Patio Door Transom Traditional or Contemporary	Width = transom width + 3/4" (19) Height = transom height + 3/4" (19)	 Patio Door Transom Traditional or Contemporary	Width = transom width - 21.5" (546) Height = transom height - 7.84" (199)
	Triple Width = transom width + 3/4" (19) Height = transom height + 3/4" (19)		Triple Width = transom width - 31.78" (807) Height = transom height - 7.84" (199)

Custom Size Patio Door Shipping Information

	DOOR PRODUCT TYPE & SIZE		FACTORY-ASSEMBLED	UNASSEMBLED with Assembled Frame <small>Panels ship separately</small>	UNASSEMBLED with Unassembled Frame <small>Panels ship separately</small>
	8' TALL OR LESS	Single-Panel	Gliding	√	
Single-Panel		Hinged	√		
Two-Panel		Gliding	√		√
Two-Panel		Hinged	√		
Three- or Four-Panel		Gliding			√
Three-Panel		Hinged	√		
OVER 8' TALL	Single-Panel	Gliding	√		
	Single-Panel	Hinged	√		
	Two-Panel	Gliding			√
	Two-Panel*	Hinged		√	
	Three- or Four-Panel	Gliding			√

*Two-panel hinged inswing patio doors over 8' (2438) tall are only available active/passive or passive/active (AP/PA).

• Dimensions in parentheses are in millimeters.

• **Minimum R.O.** (minimum rough opening) formulas provide minimum rough opening width and height dimensions. **Unobst. Glass** (unobstructed glass) formulas provide dimensions for determining area available for passage of light.

NOTES

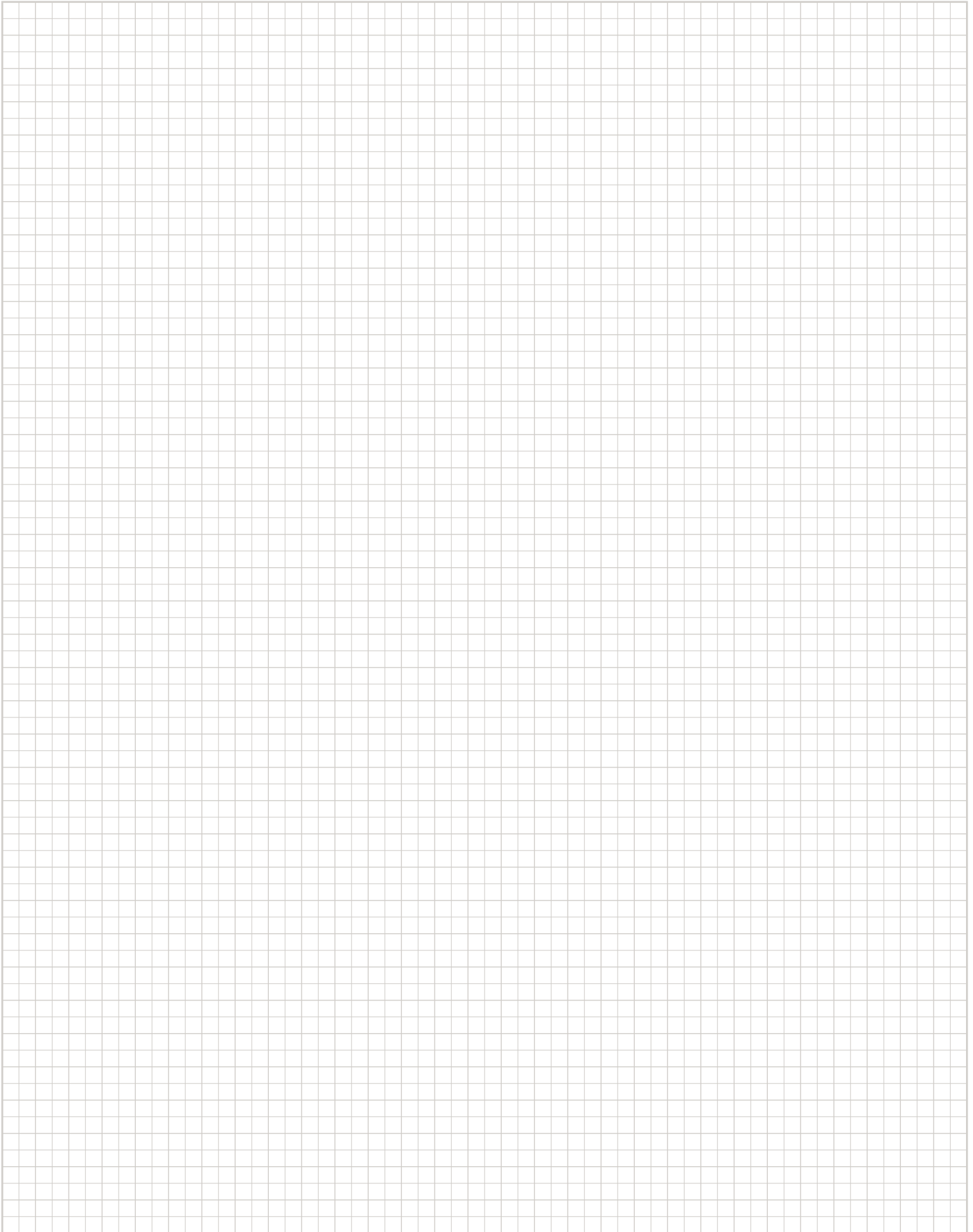

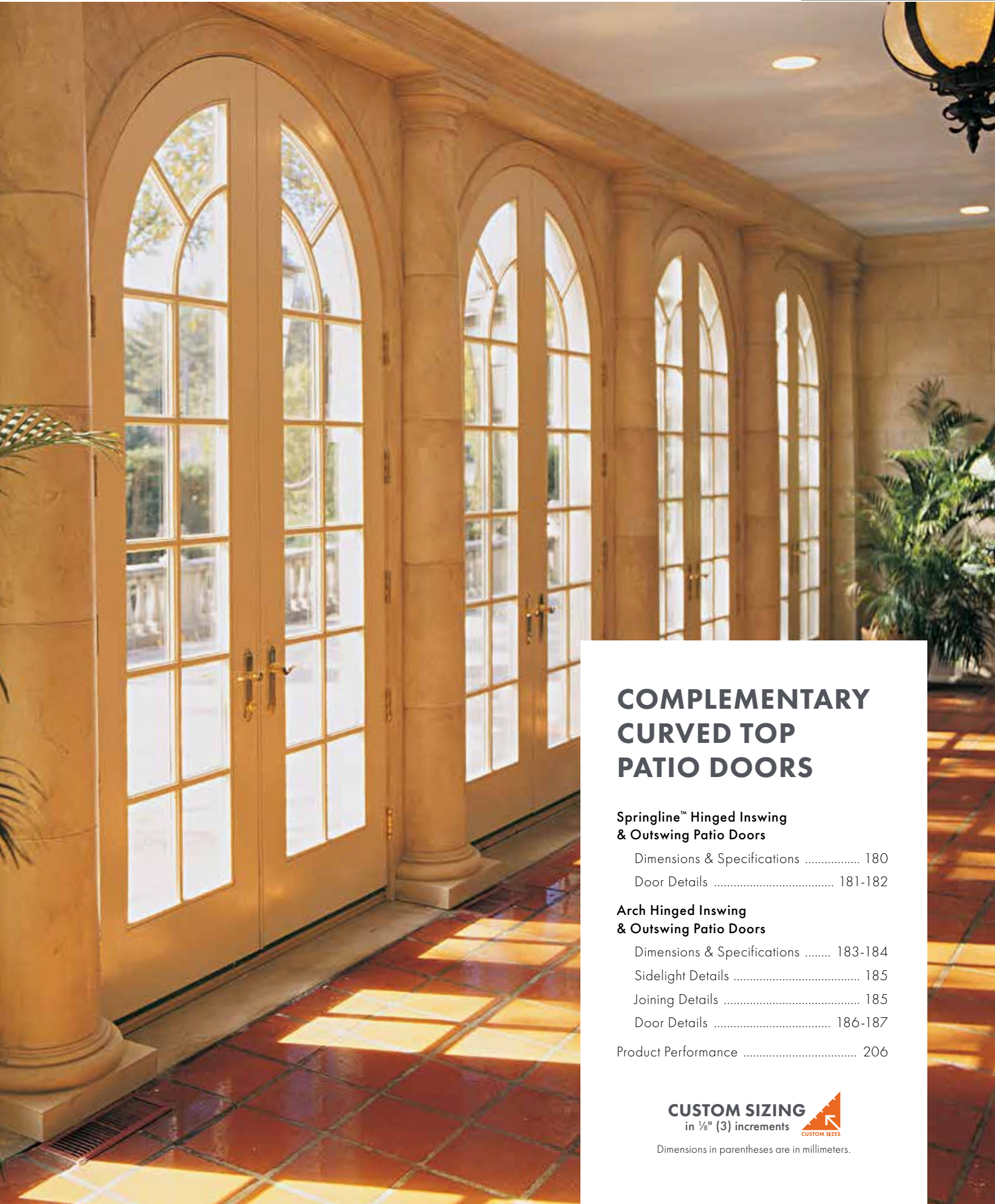

COMPLEMENTARY CURVED TOP PATIO DOORS

Springline™ Hinged Inswing & Outswing Patio Doors

Dimensions & Specifications	180
Door Details	181-182

Arch Hinged Inswing & Outswing Patio Doors

Dimensions & Specifications	183-184
Sidelight Details	185
Joining Details	185
Door Details	186-187
Product Performance	206

CUSTOM SIZING
in 1/8" (3) increments



Dimensions in parentheses are in millimeters.

COMPLEMENTARY CURVED TOP PATIO DOORS

FEATURES

FRAME

A Heavy-duty extruded aluminum cladding protects the frame exterior, providing low-maintenance durability. Standard cladding finish meets the AAMA 2604 specification. An optional finish that meets the AAMA 2605 specification is also available.

Installation flange extends 1 1/2" (38) around three sides of the unit to help properly position the unit in the opening. Installation clips are standard for increased structural anchoring to building members. Mounted around the frame perimeter, the clips rotate into position and can be bent into place against the framing members to suit all jamb conditions.

B Wood frame members are treated with a water-repellent wood preservative for long-lasting protection and performance. Radii are made of laminated continuous veneers. Lineal components are engineered wood with a pine core.

C Extruded aluminum sill is thermally broken and available in a painted bronze or gray finish. Innovative sill design provides superior water management. Standard outswing sills have an oak cap. Maple or mahogany** is optional. Inswing sills have an interior wood trim strip to match the interior finish.

D One-piece compression weatherstrip at the frame sides and head protects against air and water infiltration. Flexible thermoplastic sweep is featured at the bottom of the panel on inswing units. Outswing doors also feature a polypropylene rain skirt at the panel sides and top for added protection.

PANEL

E Heavy-duty extruded aluminum cladding protects the panel exterior, providing low-maintenance durability.

F Panel interior surfaces are unfinished wood veneers. Available species are pine, maple, vertical grain Douglas fir, oak, mahogany**, alder, mixed grain Douglas fir, hickory, cherry, white oak and walnut. Available prefinished in all interior paint colors.

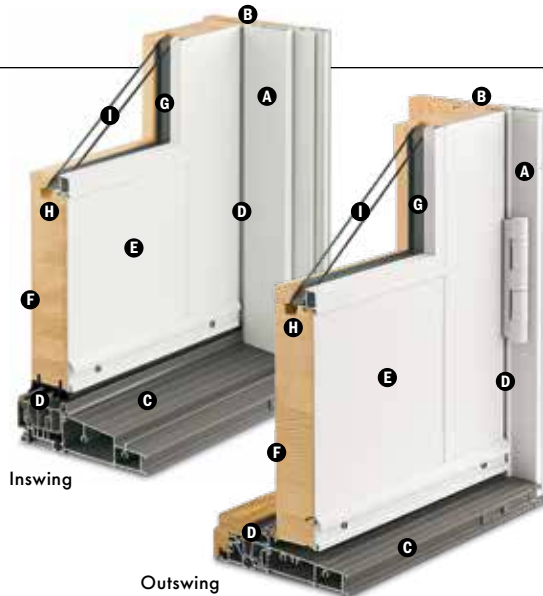

GLASS

G In addition to stainless steel glass spacers, black or white glass spacers are available to allow the spacer to blend in with the unit color.

H Silicone glazing bead combined with two-sided silicone tape provide superior weathertightness.

I High-Performance glass options include:

- Low-E4® tempered glass
- Low-E4 HeatLock® tempered glass
- Low-E4 SmartSun™ tempered glass
- Low-E4 SmartSun HeatLock tempered glass
- Low-E4 Sun tempered glass

Additional glass options are available. Contact your Andersen supplier.

A removable translucent film helps shield the glass from damage during delivery and construction, and simplifies finishing at the job site.

OPERATION

Inswing and outswing units are available. Choose left-hinged, right-hinged or stationary as viewed from the exterior.

HARDWARE

Multi-Point Locking System

The complementary hinged patio door has a multi-point locking system with a hook bolt above and below the center dead bolt. This system provides a weathertight seal and enhanced security.

Hinges

Adjustable hinges are standard on inswing doors and have ball-bearing pivots for smooth, frictionless movement. Feature easy horizontal and vertical adjustment, plus quick-release for easy panel removal. The release feature is ideal for transporting large units up stairs or to other hard-to-reach areas.

Ball-bearing hinges are standard on outswing doors and are available in finishes that coordinate with hardware trim sets. For units with a prefinished white interior, white finish hinges are standard. Also available in finishes that coordinate with hardware.

ACCESSORIES Sold Separately

FRAME

Extension Jamb

Inswing and outswing standard jamb depth is 4 9/16" (116). Inswing is also available in a 6 9/16" (167) jamb depth. Interior extension jambs are available in 1/16" (1.5) increments between 4 9/16" (116) and 7 1/8" (181). Additional dimensions are available. Contact your Andersen supplier for more information.

Interior extension jambs on inswing units will restrict the full opening of the door.

Casings



Curved interior casings are available in the same profiles as other Andersen® products. Curved exterior aluminum and wood casings are available in matching radii and a variety of profiles.

HARDWARE

Exterior Keyed Lock



A six-pin key cylinder lock is available for all patio doors in styles and finishes that coordinate with the hardware. This lock allows the door to be locked and unlocked from the exterior.

GRILLES

Grilles are available in a variety of configurations and widths.

ART GLASS

Decorative insulated art glass designs are available.

*Visit andersenwindows.com/warranty for details.

**Actual wood species is either Sapele or Sipo, both non-endangered species grown in Africa, with color and characteristics similar to Central American mahoganies.

Dimensions in parentheses are in millimeters.

EXTERIORS & INTERIORS

EXTERIOR COLORS



For custom colors, contact your Andersen supplier.

INTERIOR WOOD SPECIES



All wood interiors are unfinished unless a paint color is specified. Naturally occurring variations in grain, color and texture of wood make each door one of a kind.

INTERIOR PAINT COLORS



Also available in 11 exterior colors shown above and custom colors. Painted colors on pine, except anodized silver; anodized silver on maple only. Dark bronze and black also available on maple.

A-Series Complementary Curved Top Patio Doors

HARDWARE Sold Separately



- YUMA®**
Distressed Bronze
Distressed Nickel
- ENCINO®**
Distressed Bronze
Distressed Nickel
- NEWBURY®**
Antique Brass
Bright Brass
Oil Rubbed Bronze
Satin Nickel
- ANVERS®**
Bright Brass
Oil Rubbed Bronze
Satin Nickel
- ALBANY**
Black
Stone
White
- TRIBECA®**
Black
Stone
White

Bold name denotes finish shown.

HARDWARE FINISHES

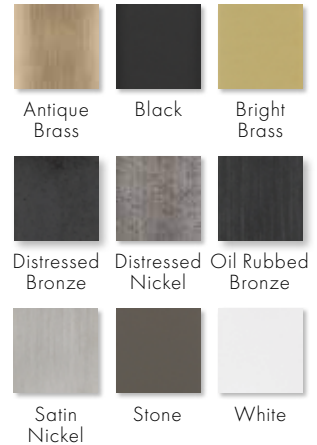

FSB® HARDWARE FOR HINGED PATIO DOORS

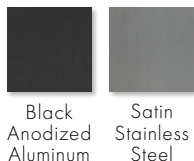

*Actual wood species is either Sapele or Sipo, both non-endangered species grown in Africa, with color and characteristics similar to Central American mahoganies.

**FSB style 1102 is not available in black anodized aluminum.

Matching hinges available in most hardware finishes for inswing patio doors; excludes FSB hardware. Mix and match interior and exterior style and finish options are available; excludes FSB hardware.

Bright brass and satin nickel finishes feature a 10-year limited warranty.

Albany and Tribeca hardware are zinc die-cast with powder-coated durable finish; Yuma, Encino, Newbury and Anvers are solid forged brass..

Distressed bronze and oil rubbed bronze are "living" finishes that will change with time and use.

Printing limitations prevent exact replication of colors and finishes.

See your Andersen supplier for actual color and finish samples.

"FSB" is a registered trademark of Franz Schneider Brakel GmbH & Co.

COMPLEMENTARY CURVED TOP PATIO DOORS

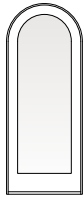

1 AHISDxx80

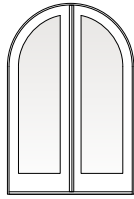

1 AHISDxx80AP/PA



Custom-size doors are available in 1/8" (3) increments.

Traditional panels are standard. Custom-designed and 3/4-light panels are also available. Stationary doors are also available (i.e., 3180S or 4080SS). Add AHISD to "Door Number" listed in table (i.e., AHISD3180).

Complementary Springline™ Hinged Inswing Patio Door Dimensions and Specifications

Door Number	Number of Panels Open*	Door Dimensions				Min. Rough Opening		Clear Opening Area Sq. Ft./ (m ²)	Clear Opening Maximums			Glass Area Sq. Ft./ (m ²)	Vent Area Sq. Ft./ (m ²)	Overall Door Area Sq. Ft./ (m ²)
		Radius Inches/(mm)	Side Height Inches/(mm)	Width Inches/(mm)	Height Inches/(mm)	Width Inches/(mm)	Height Inches/(mm)		90° Open Position Width Inches/(mm)	Full Open Position Width Inches/(mm)	Height Inches/(mm)			
3180	1	18" (457)	77 1/2" (1969)	35 15/16" (913)	95 1/2" (2426)	37" (940)	96" (2438)	17.26 (1.60)	30 7/8" (784)	32 13/16" (833)	75 3/4" (1924)	13.28 (1.23)	20.27 (1.88)	22.88 (2.13)
3380	1	19" (483)	76 1/2" (1943)	37 15/16" (964)	95 1/2" (2426)	39" (991)	96" (2438)	18.07 (1.68)	32 7/8" (835)	34 13/16" (884)	74 3/4" (1899)	14.31 (1.33)	21.45 (1.99)	24.09 (2.24)
4080	2	23 5/8" (600)	71 7/8" (1826)	47 1/4" (1200)	95 1/2" (2426)	48" (1219)	96" (2438)	21.34 (1.98)	39 15/16" (1014)	43 13/16" (1113)	70 1/8" (1781)	13.27 (1.23)	26.72 (2.48)	29.67 (2.76)
4080	1	23 5/8" (600)	71 7/8" (1826)	47 1/4" (1200)	95 1/2" (2426)	48" (1219)	96" (2438)	10.17 (0.94)	18 15/16" (481)	20 7/8" (530)	70 1/8" (1781)	13.27 (1.23)	11.72 (1.09)	29.67 (2.76)
5080	2	29 5/8" (752)	65 7/8" (1673)	59 1/4" (1505)	95 1/2" (2426)	60" (1524)	96" (2438)	24.85 (2.31)	51 15/16" (1319)	55 13/16" (1418)	64 1/8" (1629)	19.14 (1.78)	33.54 (3.12)	36.68 (3.41)
5080	1	29 5/8" (752)	65 7/8" (1673)	59 1/4" (1505)	95 1/2" (2426)	60" (1524)	96" (2438)	11.97 (1.11)	24 15/16" (633)	26 7/8" (683)	64 1/8" (1629)	19.14 (1.78)	14.53 (1.35)	36.68 (3.41)
5480	2	31 5/8" (803)	63 7/8" (1622)	63 1/4" (1607)	95 1/2" (2426)	64" (1626)	96" (2438)	25.80 (2.40)	55 15/16" (1421)	59 13/16" (1519)	62 1/8" (1578)	21.05 (1.96)	35.77 (3.32)	38.97 (3.62)
5480	1	31 5/8" (803)	63 7/8" (1622)	63 1/4" (1607)	95 1/2" (2426)	64" (1626)	96" (2438)	12.46 (1.16)	26 15/16" (684)	28 7/8" (733)	62 1/8" (1578)	21.05 (1.96)	15.45 (1.44)	38.97 (3.62)
6080	2	35 5/8" (905)	59 7/8" (1521)	71 1/4" (1810)	95 1/2" (2426)	72" (1829)	96" (2438)	27.37 (2.54)	63 15/16" (1624)	67 13/16" (1722)	58 1/8" (1476)	24.79 (2.30)	40.15 (3.73)	43.47 (4.04)
6080	1	35 5/8" (905)	59 7/8" (1521)	71 1/4" (1810)	95 1/2" (2426)	72" (1829)	96" (2438)	13.27 (1.23)	30 7/8" (786)	32 7/8" (835)	58 1/8" (1476)	24.79 (2.30)	17.24 (1.60)	43.47 (4.04)
6480	2	37 5/8" (956)	57 7/8" (1470)	75 1/4" (1911)	95 1/2" (2426)	76" (1930)	96" (2438)	27.99 (2.60)	67 15/16" (1726)	71 13/16" (1824)	56 1/8" (1426)	26.63 (2.47)	42.30 (3.93)	45.69 (4.24)
6480	1	37 5/8" (956)	57 7/8" (1470)	75 1/4" (1911)	95 1/2" (2426)	76" (1930)	96" (2438)	13.59 (1.26)	32 15/16" (837)	34 7/8" (886)	56 1/8" (1426)	26.63 (2.47)	19.84 (1.84)	45.69 (4.24)

* "Door Dimension" always refers to outside frame-to-frame dimension.

* "Minimum Rough Opening" dimensions may need to be increased to allow for use of building wraps, flashing, sill panning, brackets, fasteners or other items. See pages 226-227 for more details.

* Dimensions in parentheses are in millimeters or square meters.

* For two-panel patio doors with one panel open, clear opening is based on active panel being open and passive panel being closed.

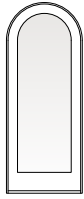

1 AOSDxx80

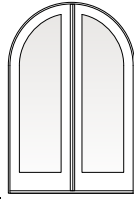

1 AOSDxx80AP/PA



Custom-size doors are available in 1/8" (3) increments.

Traditional panels are standard. Custom-designed and 3/4-light panels are also available. Stationary doors are also available (i.e., 3180S or 4080SS). Add AOSD to "Door Number" listed in table (i.e., AOSD3180).

Complementary Springline™ Hinged Outswing Patio Door Dimensions and Specifications

Door Number	Number of Panels Open*	Door Dimensions				Min. Rough Opening		Clear Opening Area Sq. Ft./ (m ²)	Clear Opening Maximums			Glass Area Sq. Ft./ (m ²)	Vent Area Sq. Ft./ (m ²)	Overall Door Area Sq. Ft./ (m ²)
		Radius Inches/(mm)	Side Height Inches/(mm)	Width Inches/(mm)	Height Inches/(mm)	Width Inches/(mm)	Height Inches/(mm)		90° Open Position Width Inches/(mm)	Full Open Position Width Inches/(mm)	Height Inches/(mm)			
3180	1	18" (457)	77 1/2" (1969)	35 15/16" (913)	95 1/2" (2426)	37" (940)	96" (2438)	17.52 (1.63)	31 3/8" (797)	33 5/16" (846)	75 3/4" (1924)	13.28 (1.23)	20.53 (1.91)	22.88 (2.13)
3380	1	19" (483)	76 1/2" (1943)	37 15/16" (964)	95 1/2" (2426)	39" (991)	96" (2438)	18.33 (1.70)	33 3/8" (848)	35 5/16" (897)	74 3/4" (1899)	14.31 (1.33)	21.71 (2.02)	24.09 (2.24)
4080	2	23 5/8" (600)	71 7/8" (1826)	47 1/4" (1200)	95 1/2" (2426)	48" (1219)	96" (2438)	21.73 (2.02)	40 11/16" (1033)	44 5/8" (1133)	70 1/8" (1781)	13.27 (1.23)	27.12 (2.52)	29.67 (2.76)
4080	1	23 5/8" (600)	71 7/8" (1826)	47 1/4" (1200)	95 1/2" (2426)	48" (1219)	96" (2438)	10.35 (0.96)	19 1/4" (489)	21 1/4" (540)	70 1/8" (1781)	13.27 (1.23)	11.72 (1.09)	29.67 (2.76)
5080	2	29 5/8" (752)	65 7/8" (1673)	59 1/4" (1505)	95 1/2" (2426)	60" (1524)	96" (2438)	25.22 (2.34)	52 11/16" (1338)	56 5/8" (1438)	64 1/8" (1629)	19.14 (1.78)	33.90 (3.15)	36.68 (3.41)
5080	1	29 5/8" (752)	65 7/8" (1673)	59 1/4" (1505)	95 1/2" (2426)	60" (1524)	96" (2438)	12.13 (1.13)	25 1/4" (641)	27 1/4" (692)	64 1/8" (1629)	19.14 (1.78)	14.53 (1.35)	36.68 (3.41)
5480	2	31 5/8" (803)	63 7/8" (1622)	63 1/4" (1607)	95 1/2" (2426)	64" (1626)	96" (2438)	26.16 (2.43)	56 11/16" (1440)	60 5/8" (1540)	62 1/8" (1578)	21.05 (1.96)	36.12 (3.36)	38.97 (3.62)
5480	1	31 5/8" (803)	63 7/8" (1622)	63 1/4" (1607)	95 1/2" (2426)	64" (1626)	96" (2438)	12.62 (1.17)	27 1/4" (692)	29 1/4" (743)	62 1/8" (1578)	21.05 (1.96)	15.45 (1.44)	38.97 (3.62)
6080	2	35 5/8" (905)	59 7/8" (1521)	71 1/4" (1810)	95 1/2" (2426)	72" (1829)	96" (2438)	27.70 (2.57)	64 11/16" (1643)	68 5/8" (1743)	58 1/8" (1476)	24.79 (2.30)	40.48 (3.76)	43.47 (4.04)
6080	1	35 5/8" (905)	59 7/8" (1521)	71 1/4" (1810)	95 1/2" (2426)	72" (1829)	96" (2438)	13.42 (1.25)	31 1/4" (794)	33 1/4" (845)	58 1/8" (1476)	24.79 (2.30)	17.24 (1.60)	43.47 (4.04)
6480	2	37 5/8" (956)	57 7/8" (1470)	75 1/4" (1911)	95 1/2" (2426)	76" (1930)	96" (2438)	28.31 (2.63)	68 11/16" (1745)	72 5/8" (1845)	56 1/8" (1426)	26.63 (2.47)	42.62 (3.96)	45.69 (4.24)
6480	1	37 5/8" (956)	57 7/8" (1470)	75 1/4" (1911)	95 1/2" (2426)	76" (1930)	96" (2438)	13.74 (1.28)	33 1/4" (845)	35 1/4" (895)	56 1/8" (1426)	26.63 (2.47)	19.84 (1.84)	45.69 (4.24)

* "Door Dimension" always refers to outside frame-to-frame dimension.

* "Minimum Rough Opening" dimensions may need to be increased to allow for use of building wraps, flashing, sill panning, brackets, fasteners or other items. See pages 226-227 for more details.

* Dimensions in parentheses are in millimeters or square meters.

* For two-panel patio doors with one panel open, clear opening is based on active panel being open and passive panel being closed.

Complementary Springline™ Hinged Inswing Patio Door Details – 4 9/16" (116) Base Jamb Depth

Scale 1 1/2" (38) = 1'-0" (305) – 1:8

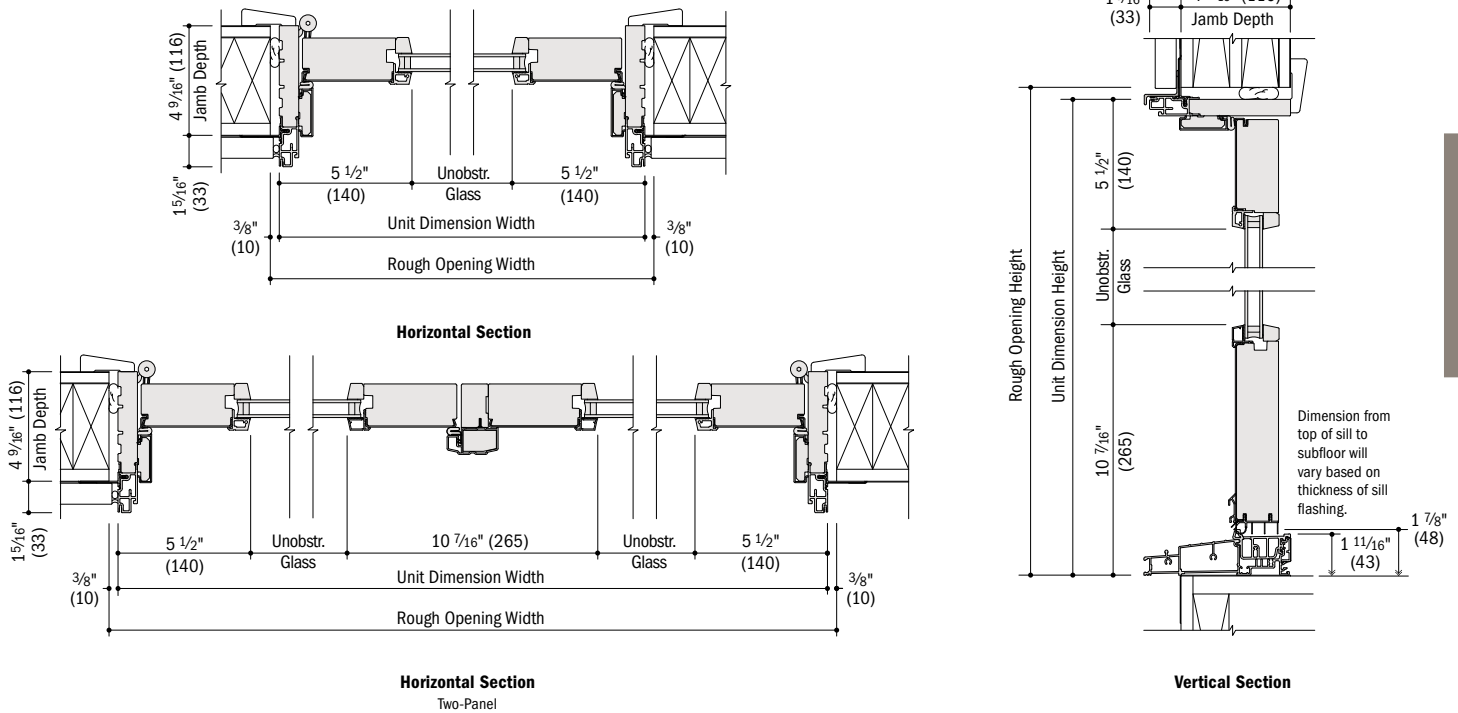

A-Series
Complementary
Curved Top Patio Doors

Complementary Springline™ Hinged Inswing Patio Door Details – 6 9/16" (167) Base Jamb Depth

Scale 1 1/2" (38) = 1'-0" (305) – 1:8

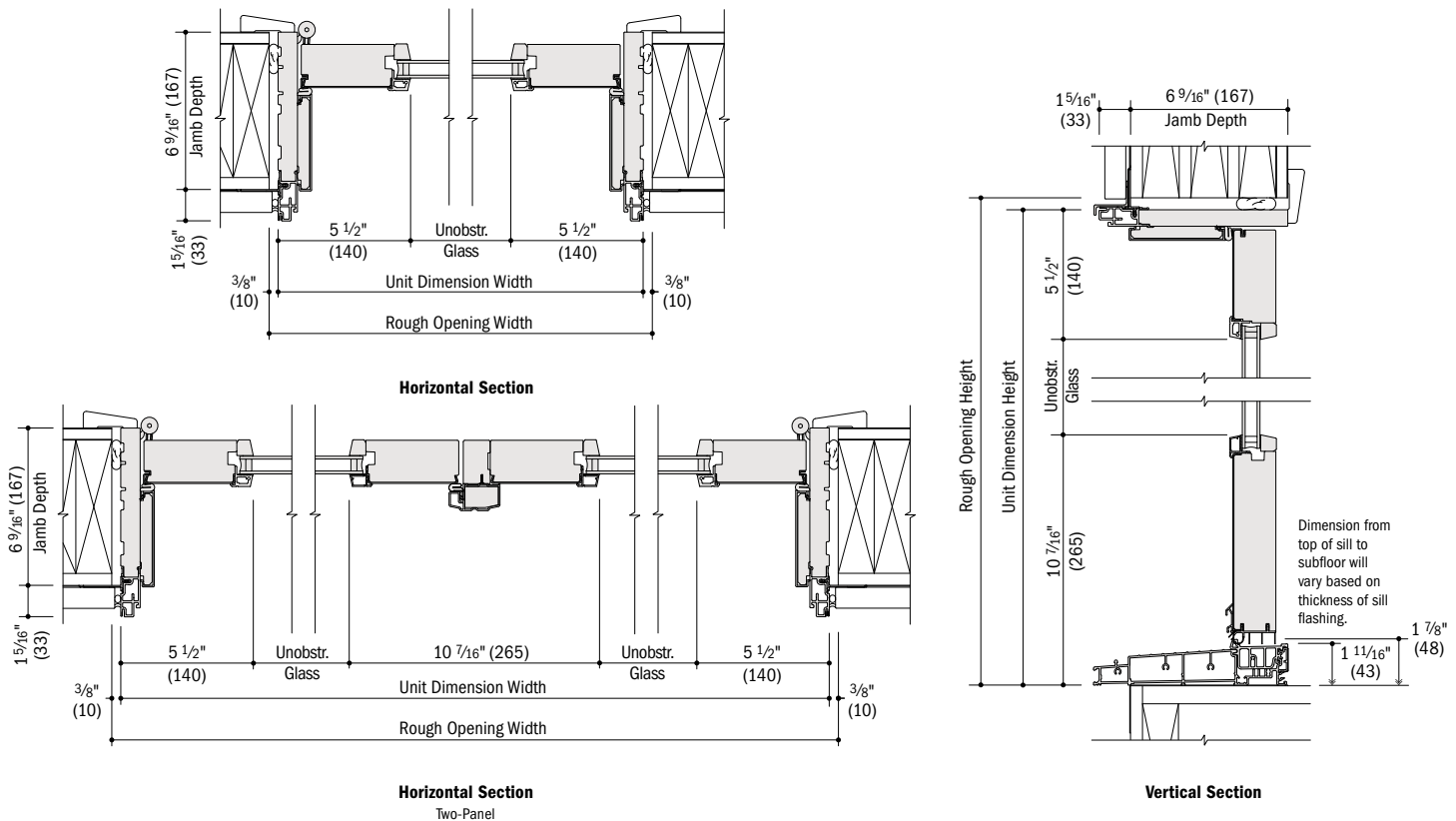

- 4 9/16" (116) and 6 9/16" (167) overall jamb depth measurements are from back side of installation flange.
- Light-colored areas are parts included with door. Dark-colored areas are additional Andersen® parts required to complete door assembly as shown.
- **Minimum rough openings may need to be increased to allow for use of building wraps, flashing, sill panning, brackets, fasteners or other items. See installation information on pages 226-227.**
- Details are for illustration only and are not intended to represent product installation methods or materials. Refer to product installation guides at andersenwindows.com.
- Dimensions in parentheses are in millimeters.

COMPLEMENTARY CURVED TOP PATIO DOORS

Complementary Springline™ Hinged Outswing Patio Door Details

Scale 1 1/2" (38) = 1'-0" (305) – 1:8

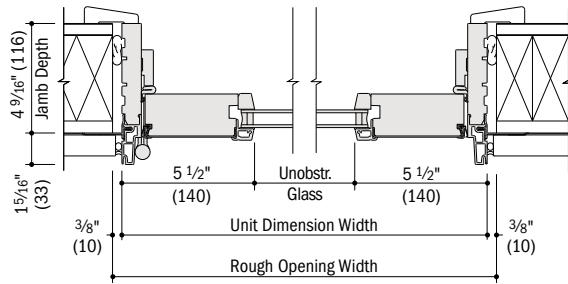

Horizontal Section

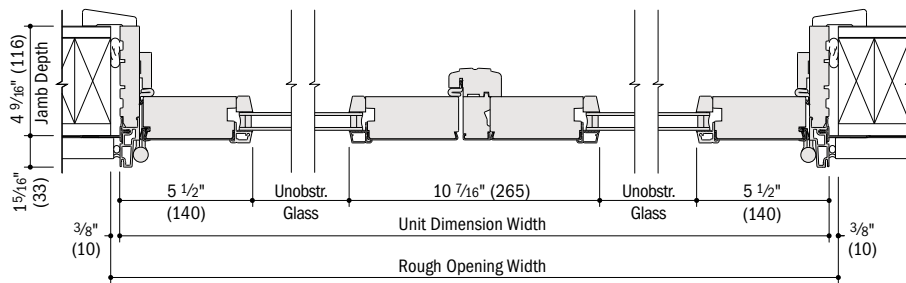

Horizontal Section
Two-Panel

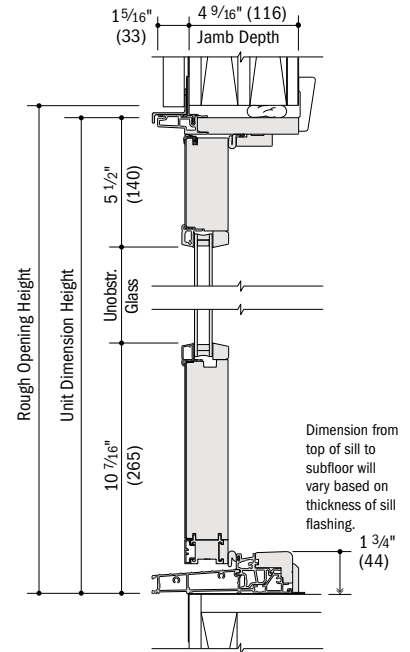

Vertical Section

- 4 9/16" (116) overall jamb depth measurements are from back side of installation flange.
- Light-colored areas are parts included with door. Dark-colored areas are additional Andersen® parts required to complete door assembly as shown.
- **Minimum rough openings may need to be increased to allow for use of building wraps, flashing, sill panning, brackets, fasteners or other items. See installation information on pages 226-227.**
- Details are for illustration only and are not intended to represent product installation methods or materials. Refer to product installation guides at andersenwindows.com.
- Dimensions in parentheses are in millimeters.

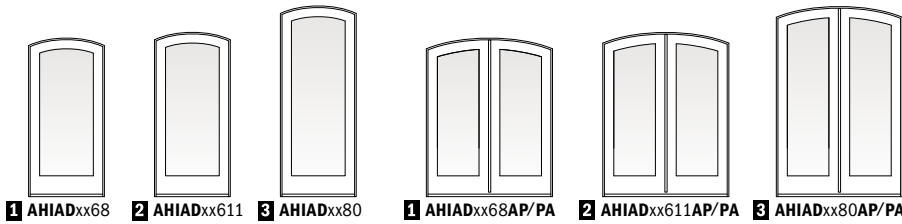

Custom-size doors are available in 1/8" (3) increments. Traditional panels are standard. Custom-designed and 3/4-light panels are also available. Stationary doors are also available (i.e., 2168S or 4068SS). Add AHIA to "Door Number" listed in table (i.e., AHIAH2168).

Complementary Arch Hinged Inswing Patio Door Dimensions and Specifications

Door Number	Number of Panels Open*	Door Dimensions				Min. Rough Opening		Clear Opening Area Sq. Ft./ (m ²)	Clear Opening Maximums			Glass Area Sq. Ft./ (m ²)	Vent Area Sq. Ft./ (m ²)	Overall Door Area Sq. Ft./ (m ²)
		Radius Inches/(mm)	Side Height Inches/(mm)	Width Inches/(mm)	Height Inches/(mm)	Width Inches/(mm)	Height Inches/(mm)		90° Open Position Width Inches/(mm)	Full Open Position Width Inches/(mm)	Height Inches/(mm)			
2168	1	36" (914)	77 1/16" (1967)	23 15/16" (608)	79 1/2" (2019)	25" (635)	80" (2032)	10.79 (1.00)	18 1/8" (479)	20 13/16" (529)	74 11/16" (1897)	5.66 (0.53)	12.46 (1.16)	14.49 (1.35)
2768	1	48" (1219)	77 1/8" (1959)	29 15/16" (760)	79 1/2" (2019)	31" (787)	80" (2032)	13.84 (1.29)	24 7/8" (632)	26 13/16" (681)	74 5/16" (1888)	8.28 (0.77)	15.70 (1.46)	17.85 (1.66)
2968	1	48" (1219)	76 3/4" (1949)	31 15/16" (811)	79 1/2" (2019)	33" (838)	80" (2032)	14.81 (1.38)	26 1/8" (683)	28 13/16" (732)	74" (1880)	9.15 (0.85)	16.77 (1.56)	18.95 (1.76)
3168	1	48" (1219)	76" (1930)	35 15/16" (913)	79 1/2" (2019)	37" (940)	80" (2032)	16.71 (1.55)	30 1/8" (784)	32 13/16" (833)	73 5/16" (1862)	10.87 (1.01)	18.88 (1.75)	21.13 (1.96)
3368	1	48" (1219)	75 5/8" (1921)	37 15/16" (964)	79 1/2" (2019)	39" (991)	80" (2032)	17.86 (1.66)	32 7/8" (835)	34 13/16" (884)	73 7/8" (1876)	11.72 (1.09)	22.01 (2.04)	24.36 (2.26)
21611	1	36" (914)	80 5/16" (2040)	23 15/16" (608)	82 3/8" (2092)	25" (635)	83" (2108)	11.21 (1.04)	18 1/8" (479)	20 13/16" (529)	77 9/16" (1970)	5.93 (0.55)	14.39 (1.34)	16.65 (1.55)
27611	1	48" (1219)	80" (2032)	29 15/16" (760)	82 3/8" (2092)	31" (787)	83" (2108)	14.37 (1.33)	24 7/8" (632)	26 13/16" (681)	77 3/16" (1961)	8.68 (0.81)	18.17 (1.69)	20.55 (1.91)
29611	1	48" (1219)	79 5/8" (2022)	31 15/16" (811)	82 3/8" (2092)	33" (838)	83" (2108)	15.38 (1.43)	26 1/8" (683)	28 13/16" (732)	76 7/8" (1953)	9.58 (0.89)	19.41 (1.80)	21.83 (2.03)
31611	1	48" (1219)	78 7/8" (2003)	35 15/16" (913)	82 3/8" (2092)	37" (940)	83" (2108)	17.36 (1.61)	30 7/8" (784)	32 13/16" (833)	76 3/16" (1935)	11.39 (1.06)	21.89 (2.03)	24.37 (2.26)
33611	1	48" (1219)	78 1/2" (1994)	37 15/16" (964)	82 3/8" (2092)	39" (991)	83" (2108)	18.55 (1.72)	32 7/8" (835)	34 13/16" (884)	76 3/4" (1949)	12.28 (1.14)	25.19 (2.34)	27.78 (2.58)
2180	1	36" (914)	93 7/16" (2373)	23 15/16" (608)	95 1/2" (2426)	25" (635)	96" (2438)	13.11 (1.22)	18 1/8" (479)	20 13/16" (529)	90 11/16" (2303)	7.09 (0.66)	16.31 (1.52)	18.81 (1.75)
2780	1	48" (1219)	93 1/8" (2365)	29 15/16" (760)	95 1/2" (2426)	31" (787)	96" (2438)	16.82 (1.56)	24 7/8" (632)	26 13/16" (681)	90 5/16" (2294)	10.38 (0.96)	20.63 (1.92)	23.25 (2.16)
2980	1	48" (1219)	92 3/4" (2356)	31 15/16" (811)	95 1/2" (2426)	33" (838)	96" (2438)	18.01 (1.67)	26 1/8" (683)	28 13/16" (732)	90" (2286)	11.47 (1.07)	22.06 (2.05)	24.71 (2.30)
3180	1	48" (1219)	92" (2337)	35 15/16" (913)	95 1/2" (2426)	37" (940)	96" (2438)	20.35 (1.89)	30 1/8" (784)	32 13/16" (833)	89 5/16" (2269)	13.63 (1.27)	24.89 (2.31)	27.62 (2.57)
3380	1	48" (1219)	91 5/8" (2327)	37 15/16" (964)	95 1/2" (2426)	39" (991)	96" (2438)	21.73 (2.02)	32 7/8" (835)	34 13/16" (884)	89 7/8" (2283)	14.71 (1.37)	28.38 (2.64)	31.20 (2.90)
4068	2	48" (1219)	73 5/16" (1862)	47 1/4" (1200)	79 1/2" (2019)	48" (1219)	80" (2032)	21.56 (2.00)	39 15/16" (1014)	43 13/16" (1113)	70 7/8" (1800)	10.93 (1.02)	25.61 (2.38)	28.07 (2.61)
4068	1	48" (1219)	73 5/16" (1862)	47 1/4" (1200)	79 1/2" (2019)	48" (1219)	80" (2032)	10.27 (0.95)	18 15/16" (481)	20 7/8" (530)	70 7/8" (1800)	10.93 (1.02)	12.22 (1.14)	28.07 (2.61)
5068	2	96" (2438)	74 13/16" (1900)	59 1/4" (1505)	79 1/2" (2019)	60" (1524)	80" (2032)	27.95 (2.60)	51 15/16" (1319)	55 13/16" (1418)	72 1/8" (1832)	16.30 (1.51)	32.24 (3.00)	34.97 (3.25)
5068	1	96" (2438)	74 13/16" (1900)	59 1/4" (1505)	79 1/2" (2019)	60" (1524)	80" (2032)	13.46 (1.25)	24 15/16" (633)	26 7/8" (683)	72 1/8" (1832)	16.30 (1.51)	15.54 (1.44)	34.97 (3.25)
5468	2	96" (2438)	74 1/8" (1883)	63 1/4" (1607)	79 1/2" (2019)	64" (1626)	80" (2032)	29.70 (2.76)	55 15/16" (1421)	59 13/16" (1519)	71 1/2" (1816)	17.97 (1.67)	34.29 (3.19)	37.09 (3.45)
5468	1	96" (2438)	74 1/8" (1883)	63 1/4" (1607)	79 1/2" (2019)	64" (1626)	80" (2032)	14.34 (1.33)	26 15/16" (684)	28 7/8" (733)	71 1/2" (1816)	17.97 (1.67)	16.56 (1.54)	37.09 (3.45)
6068	2	96" (2438)	72 5/8" (1845)	71 1/4" (1810)	79 1/2" (2019)	72" (1829)	80" (2032)	32.99 (3.06)	63 15/16" (1624)	67 13/16" (1722)	70 1/16" (1780)	21.25 (1.97)	38.33 (3.56)	41.27 (3.83)
6068	1	96" (2438)	72 5/8" (1845)	71 1/4" (1810)	79 1/2" (2019)	72" (1829)	80" (2032)	16.00 (1.49)	30 15/16" (786)	32 7/8" (835)	70 1/16" (1780)	21.25 (1.97)	18.58 (1.73)	41.27 (3.83)
6468	2	96" (2438)	71 13/16" (1824)	75 1/4" (1911)	79 1/2" (2019)	76" (1930)	80" (2032)	34.53 (3.21)	67 15/16" (1726)	71 13/16" (1824)	69 1/4" (1759)	22.86 (2.12)	44.22 (4.11)	47.36 (4.40)
6468	1	96" (2438)	71 13/16" (1824)	75 1/4" (1911)	79 1/2" (2019)	76" (1930)	80" (2032)	16.77 (1.56)	32 15/16" (837)	34 7/8" (886)	69 1/4" (1759)	22.86 (2.12)	21.53 (2.00)	47.36 (4.40)
40611	2	48" (1219)	76 3/16" (1935)	47 1/4" (1200)	82 3/8" (2092)	48" (1219)	83" (2108)	22.44 (2.08)	39 15/16" (1014)	43 13/16" (1113)	73 3/4" (1873)	11.46 (1.06)	29.64 (2.75)	32.34 (3.00)
40611	1	48" (1219)	76 3/16" (1935)	47 1/4" (1200)	82 3/8" (2092)	48" (1219)	83" (2108)	10.69 (0.99)	18 15/16" (481)	20 7/8" (530)	73 3/4" (1873)	11.46 (1.06)	14.29 (1.33)	32.34 (3.00)
50611	2	96" (2438)	77 11/16" (1973)	59 1/4" (1505)	82 3/8" (2092)	60" (1524)	83" (2108)	29.07 (2.70)	51 15/16" (1319)	55 13/16" (1418)	75" (1905)	17.09 (1.59)	37.35 (3.47)	40.32 (3.75)
50611	1	96" (2438)	77 11/16" (1973)	59 1/4" (1505)	82 3/8" (2092)	60" (1524)	83" (2108)	14.00 (1.30)	24 15/16" (633)	26 7/8" (683)	75" (1905)	17.09 (1.59)	18.15 (1.69)	40.32 (3.75)
54611	2	96" (2438)	77" (1956)	63 1/4" (1607)	82 3/8" (2092)	64" (1626)	83" (2108)	30.89 (2.87)	55 15/16" (1421)	59 13/16" (1519)	74 3/8" (1889)	18.84 (1.75)	39.77 (3.69)	42.80 (3.98)
54611	1	96" (2438)	77" (1956)	63 1/4" (1607)	82 3/8" (2092)	64" (1626)	83" (2108)	14.91 (1.39)	26 15/16" (684)	28 7/8" (733)	74 3/8" (1889)	18.84 (1.75)	19.35 (1.80)	42.80 (3.98)
60611	2	96" (2438)	75 1/2" (1918)	71 1/4" (1810)	82 3/8" (2092)	72" (1829)	83" (2108)	34.35 (3.19)	63 15/16" (1624)	67 13/16" (1722)	72 15/16" (1853)	22.28 (2.07)	44.53 (4.14)	47.71 (4.43)
60611	1	96" (2438)	75 1/2" (1918)	71 1/4" (1810)	82 3/8" (2092)	72" (1829)	83" (2108)	16.65 (1.55)	30 15/16" (786)	32 7/8" (835)	72 15/16" (1853)	22.28 (2.07)	21.74 (2.02)	47.71 (4.43)
64611	2	96" (2438)	74 11/16" (1897)	75 1/4" (1911)	82 3/8" (2092)	76" (1930)	83" (2108)	35.97 (3.34)	67 15/16" (1726)	71 13/16" (1824)	72 1/8" (1832)	23.98 (2.23)	50.78 (4.72)	54.16 (5.03)
64611	1	96" (2438)	74 11/16" (1897)	75 1/4" (1911)	82 3/8" (2092)	76" (1930)	83" (2108)	17.47 (1.62)	32 15/16" (837)	34 7/8" (886)	72 1/8" (1832)	23.98 (2.23)	25.22 (2.34)	54.16 (5.03)
4080	2	48" (1219)	89 5/16" (2269)	47 1/4" (1200)	95 1/2" (2426)	48" (1219)	96" (2438)	26.43 (2.46)	39 15/16" (1014)	43 13/16" (1113)	86 7/8" (2207)	13.76 (1.28)	33.66 (3.13)	36.60 (3.40)
4080	1	48" (1219)	89 5/16" (2269)	47 1/4" (1200)	95 1/2" (2426)	48" (1219)	96" (2438)	12.59 (1.17)	18 15/16" (481)	20 7/8" (530)	86 7/8" (2207)	13.76 (1.28)	14.29 (1.33)	36.60 (3.40)
5080	2	96" (2438)	90 13/16" (2307)	59 1/4" (1505)	95 1/2" (2426)	60" (1524)	96" (2438)	34.16 (3.17)	51 15/16" (1319)	55 13/16" (1418)	88 1/8" (2238)	20.50 (1.90)	42.47 (3.95)	45.67 (4.24)
5080	1	96" (2438)	90 13/16" (2307)	59 1/4" (1505)	95 1/2" (2426)	60" (1524)	96" (2438)	16.45 (1.53)	24 15/16" (633)	26 7/8" (683)	88 1/8" (2238)	20.50 (1.90)	18.15 (1.69)	45.67 (4.24)
5480	2	96" (2438)	90 1/8" (2289)	63 1/4" (1607)	95 1/2" (2426)	64" (1626)	96" (2438)	36.34 (3.38)	55 15/16" (1421)	59 13/16" (1519)	87 1/2" (2223)	22.61 (2.10)	45.24 (4.20)	48.51 (4.51)
5480	1	96" (2438)	90 1/8" (2289)	63 1/4" (1607)	95 1/2" (2426)	64" (1626)	96" (2438)	17.55 (1.63)	26 15/16" (684)	28 7/8" (733)	87 1/2" (2223)	22.61 (2.10)	19.35 (1.80)	48.51 (4.51)
6080	2	96" (2438)	88 5/8" (2251)	71 1/4" (1810)	95 1/2" (2426)	72" (1829)	96" (2438)	40.53 (3.77)	63 15/16" (1624)	67 13/16" (1722)	86 1/16" (2186)	26.78 (2.49)	50.73 (4.71)	54.14 (5.03)
6080	1	96" (2438)	88 5/8" (2251)	71 1/4" (1810)	95 1/2" (2426)	72" (1829)	96" (2438)	19.65 (1.83)	30 15/16" (786)	32 7/8" (835)	86 1/16" (2186)	26.78 (2.49)	21.74 (2.02)	54.14 (5.03)
6480	2	96" (2438)	87 13/16" (2230)	75 1/4" (1911)	95 1/2" (2426)	76" (1930)	96" (2438)	42.51 (3.95)	67 15/16" (1726)	71 13/16" (1824)	85 1/4" (2165)	28.83 (2.68)	57.33 (5.33)	60.95 (5.66)
6480	1	96" (2438)	87 13/16" (2230)	75 1/4" (1911)	95 1/2" (2426)	76" (1930)	96" (2438)	20.65 (1.92)	32 15/16" (837)	34 7/8" (886)	85 1/4" (2165)	28.83 (2.68)	25.22 (2.34)	60.95 (5.66)

* "Door Dimension" always refers to outside frame-to-frame dimension.
 * "Minimum Rough Opening" dimensions may need to be increased to allow for use of building wraps, flashing, sill panning, brackets, fasteners or other items. See pages 226-227 for more details.
 * Dimensions in parentheses are in millimeters or square meters.
 * For two-panel patio doors with one panel open, clear opening is based on active panel being open and passive panel being closed.

A-Series Complementary Curved Top Patio Doors

COMPLEMENTARY CURVED TOP PATIO DOORS

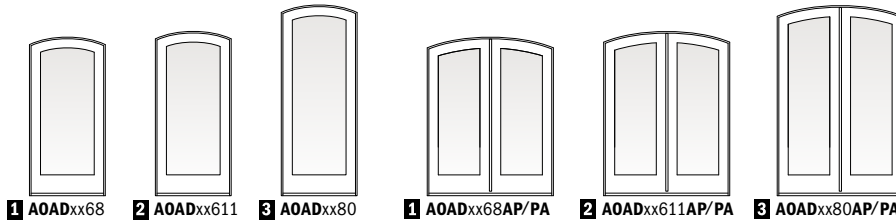

Custom-size doors are available in 1/8" (3) increments. Traditional panels are standard. Custom-designed and 3/4-light panels are also available. Stationary doors are also available (i.e., 2168S or 4068SS). Add **AOAD** to "Door Number" listed in table (i.e., **AOAD2168**).

Complementary Arch Hinged Outswing Patio Door Dimensions and Specifications

Door Number	Number of Panels Open*	Door Dimensions				Min. Rough Opening		Clear Opening Maximums				Glass Area Sq. Ft./ (m ²)	Vent Area Sq. Ft./ (m ²)	Overall Door Area Sq. Ft./ (m ²)
		Radius Inches/(mm)	Side Height Inches/(mm)	Width Inches/(mm)	Height Inches/(mm)	Width Inches/(mm)	Height Inches/(mm)	Clear Opening Area Sq. Ft./ (m ²)	90° Open Position Width Inches/(mm)	Full Open Position Width Inches/(mm)	Height Inches/(mm)			
2168	1	36" (914)	77 7/16" (1967)	23 15/16" (608)	79 1/2" (2019)	25" (635)	80" (2032)	11.06 (1.03)	19 3/8" (492)	21 5/16" (541)	74 3/4" (1899)	5.66 (0.53)	12.46 (1.16)	14.49 (1.35)
2768	1	48" (1219)	77 7/8" (1959)	29 15/16" (760)	79 1/2" (2019)	31" (787)	80" (2032)	14.11 (1.31)	25 3/8" (645)	27 5/16" (694)	74 3/8" (1889)	8.28 (0.77)	15.70 (1.46)	17.85 (1.66)
2968	1	48" (1219)	76 3/4" (1949)	31 15/16" (811)	79 1/2" (2019)	33" (838)	80" (2032)	15.08 (1.40)	27 3/8" (695)	29 5/16" (745)	74 1/16" (1881)	9.15 (0.85)	16.77 (1.56)	18.95 (1.76)
3168	1	48" (1219)	76" (1930)	35 15/16" (913)	79 1/2" (2019)	37" (940)	80" (2032)	16.97 (1.58)	31 3/8" (797)	33 5/16" (846)	73 3/8" (1864)	10.87 (1.01)	18.88 (1.75)	21.13 (1.96)
3368	1	48" (1219)	75 5/8" (1921)	37 15/16" (964)	79 1/2" (2019)	39" (991)	80" (2032)	17.90 (1.66)	33 3/8" (848)	35 5/16" (897)	73" (1854)	11.72 (1.09)	22.01 (2.04)	24.36 (2.26)
21611	1	36" (914)	80 5/16" (2040)	23 15/16" (608)	82 3/8" (2092)	25" (635)	83" (2108)	11.49 (1.07)	19 3/8" (492)	21 5/16" (541)	77 5/8" (1972)	5.93 (0.55)	14.39 (1.34)	16.65 (1.55)
27611	1	48" (1219)	80" (2032)	29 15/16" (760)	82 3/8" (2092)	31" (787)	83" (2108)	14.65 (1.36)	25 3/8" (645)	27 5/16" (694)	77 1/4" (1962)	8.68 (0.81)	18.17 (1.69)	20.55 (1.91)
29611	1	48" (1219)	79 5/8" (2022)	31 15/16" (811)	82 3/8" (2092)	33" (838)	83" (2108)	15.66 (1.45)	27 3/8" (695)	29 5/16" (745)	76 15/16" (1954)	9.58 (0.89)	19.41 (1.80)	21.83 (2.03)
31611	1	48" (1219)	78 7/8" (2003)	35 15/16" (913)	82 3/8" (2092)	37" (940)	83" (2108)	17.64 (1.64)	31 3/8" (797)	33 5/16" (846)	76 1/4" (1937)	11.39 (1.06)	21.89 (2.03)	24.37 (2.26)
33611	1	48" (1219)	78 1/2" (1994)	37 15/16" (964)	82 3/8" (2092)	39" (991)	83" (2108)	18.61 (1.73)	33 3/8" (848)	35 5/16" (897)	75 7/8" (1927)	12.28 (1.14)	25.19 (2.34)	27.78 (2.58)
2180	1	36" (914)	93 7/16" (2373)	23 15/16" (608)	95 1/2" (2426)	25" (635)	96" (2438)	13.43 (1.25)	19 3/8" (492)	21 5/16" (541)	90 3/4" (2305)	7.09 (0.66)	16.31 (1.52)	18.81 (1.75)
2780	1	48" (1219)	93 1/8" (2365)	29 15/16" (760)	95 1/2" (2426)	31" (787)	96" (2438)	17.14 (1.59)	25 3/8" (645)	27 5/16" (694)	90 3/8" (2296)	10.38 (0.96)	20.63 (1.92)	23.25 (2.16)
2980	1	48" (1219)	92 3/4" (2356)	31 15/16" (811)	95 1/2" (2426)	33" (838)	96" (2438)	18.33 (1.70)	27 3/8" (695)	29 5/16" (745)	90 1/16" (2288)	11.47 (1.07)	22.06 (2.05)	24.71 (2.30)
3180	1	48" (1219)	92" (2337)	35 15/16" (913)	95 1/2" (2426)	37" (940)	96" (2438)	20.68 (1.92)	31 3/8" (797)	33 5/16" (846)	89 3/8" (2270)	13.63 (1.27)	24.89 (2.31)	27.62 (2.57)
3380	1	48" (1219)	91 5/8" (2327)	37 15/16" (964)	95 1/2" (2426)	39" (991)	96" (2438)	21.83 (2.03)	33 3/8" (848)	35 5/16" (897)	89" (2261)	14.71 (1.37)	28.38 (2.64)	31.20 (2.90)
4068	2	48" (1219)	73 5/16" (1862)	47 1/4" (1200)	79 1/2" (2019)	48" (1219)	80" (2032)	21.93 (2.04)	40 11/16" (1033)	44 5/8" (1133)	70 3/4" (1797)	10.93 (1.02)	25.61 (2.38)	28.07 (2.61)
4068	1	48" (1219)	73 5/16" (1862)	47 1/4" (1200)	79 1/2" (2019)	48" (1219)	80" (2032)	10.44 (0.97)	19 1/4" (489)	21 1/4" (540)	70 3/4" (1797)	10.93 (1.02)	12.22 (1.14)	28.07 (2.61)
5068	2	96" (2438)	74 13/16" (1900)	59 1/4" (1505)	79 1/2" (2019)	60" (1524)	80" (2032)	28.36 (2.63)	52 11/16" (1338)	56 5/8" (1438)	72 1/8" (1832)	16.30 (1.51)	32.24 (3.00)	34.97 (3.25)
5068	1	96" (2438)	74 13/16" (1900)	59 1/4" (1505)	79 1/2" (2019)	60" (1524)	80" (2032)	13.65 (1.27)	25 1/4" (641)	27 1/4" (692)	72 1/8" (1832)	16.30 (1.51)	15.54 (1.44)	34.97 (3.25)
5468	2	96" (2438)	74 1/8" (1883)	63 1/4" (1607)	79 1/2" (2019)	64" (1626)	80" (2032)	30.08 (2.79)	56 11/16" (1440)	60 5/8" (1540)	71 7/16" (1815)	17.97 (1.67)	34.29 (3.19)	37.09 (3.45)
5468	1	96" (2438)	74 1/8" (1883)	63 1/4" (1607)	79 1/2" (2019)	64" (1626)	80" (2032)	14.51 (1.35)	27 1/4" (692)	29 1/4" (743)	71 7/16" (1815)	17.97 (1.67)	16.56 (1.54)	37.09 (3.45)
6068	2	96" (2438)	72 5/8" (1845)	71 1/4" (1810)	79 1/2" (2019)	72" (1829)	80" (2032)	33.36 (3.10)	64 11/16" (1643)	68 5/8" (1743)	70" (1778)	21.25 (1.97)	38.33 (3.56)	41.27 (3.83)
6068	1	96" (2438)	72 5/8" (1845)	71 1/4" (1810)	79 1/2" (2019)	72" (1829)	80" (2032)	16.16 (1.50)	31 1/4" (794)	33 1/4" (845)	70" (1778)	21.25 (1.97)	18.58 (1.73)	41.27 (3.83)
6468	2	96" (2438)	71 13/16" (1824)	75 1/4" (1911)	79 1/2" (2019)	76" (1930)	80" (2032)	34.89 (3.24)	68 11/16" (1745)	72 5/8" (1845)	69 3/16" (1757)	22.86 (2.12)	44.22 (4.11)	47.36 (4.40)
6468	1	96" (2438)	71 13/16" (1824)	75 1/4" (1911)	79 1/2" (2019)	76" (1930)	80" (2032)	16.94 (1.57)	33 1/4" (845)	35 1/4" (895)	69 3/16" (1757)	22.86 (2.12)	21.53 (2.00)	47.36 (4.40)
40611	2	48" (1219)	76 3/16" (1935)	47 1/4" (1200)	82 3/8" (2092)	48" (1219)	83" (2108)	22.82 (2.12)	40 11/16" (1033)	44 5/8" (1133)	73 5/8" (1870)	11.46 (1.06)	29.64 (2.75)	32.34 (3.00)
40611	1	48" (1219)	76 3/16" (1935)	47 1/4" (1200)	82 3/8" (2092)	48" (1219)	83" (2108)	10.86 (1.01)	19 1/4" (489)	21 1/4" (540)	73 5/8" (1870)	11.46 (1.06)	14.29 (1.33)	32.34 (3.00)
50611	2	96" (2438)	77 11/16" (1973)	59 1/4" (1505)	82 3/8" (2092)	60" (1524)	83" (2108)	29.49 (2.74)	52 11/16" (1338)	56 5/8" (1438)	75" (1905)	17.09 (1.59)	37.35 (3.47)	40.32 (3.75)
50611	1	96" (2438)	77 11/16" (1973)	59 1/4" (1505)	82 3/8" (2092)	60" (1524)	83" (2108)	14.19 (1.32)	25 1/4" (641)	27 1/4" (692)	75" (1905)	17.09 (1.59)	18.15 (1.69)	40.32 (3.75)
54611	2	96" (2438)	77" (1956)	63 1/4" (1607)	82 3/8" (2092)	64" (1626)	83" (2108)	31.29 (2.91)	56 11/16" (1440)	60 5/8" (1540)	74 5/16" (1888)	18.84 (1.75)	39.77 (3.69)	42.80 (3.98)
54611	1	96" (2438)	77" (1956)	63 1/4" (1607)	82 3/8" (2092)	64" (1626)	83" (2108)	15.09 (1.40)	27 1/4" (692)	29 1/4" (743)	74 5/16" (1888)	18.84 (1.75)	19.35 (1.80)	42.80 (3.98)
60611	2	96" (2438)	75 1/2" (1918)	71 1/4" (1810)	82 3/8" (2092)	72" (1829)	83" (2108)	34.73 (3.23)	64 11/16" (1643)	68 5/8" (1743)	72 7/8" (1851)	22.28 (2.07)	44.53 (4.14)	47.71 (4.43)
60611	1	96" (2438)	75 1/2" (1918)	71 1/4" (1810)	82 3/8" (2092)	72" (1829)	83" (2108)	16.83 (1.56)	31 1/4" (794)	33 1/4" (845)	72 7/8" (1851)	22.28 (2.07)	21.74 (2.02)	47.71 (4.43)
64611	2	96" (2438)	74 11/16" (1897)	75 1/4" (1911)	82 3/8" (2092)	76" (1930)	83" (2108)	36.34 (3.38)	68 11/16" (1745)	72 5/8" (1845)	72 1/16" (1830)	23.98 (2.23)	50.78 (4.72)	54.16 (5.03)
64611	1	96" (2438)	74 11/16" (1897)	75 1/4" (1911)	82 3/8" (2092)	76" (1930)	83" (2108)	17.64 (1.64)	33 1/4" (845)	35 1/4" (895)	72 1/16" (1830)	23.98 (2.23)	25.22 (2.34)	54.16 (5.03)
4080	2	48" (1219)	89 5/16" (2269)	47 1/4" (1200)	95 1/2" (2426)	48" (1219)	96" (2438)	26.88 (2.50)	40 11/16" (1033)	44 5/8" (1133)	86 3/4" (2203)	13.76 (1.28)	33.66 (3.13)	36.60 (3.40)
4080	1	48" (1219)	89 5/16" (2269)	47 1/4" (1200)	95 1/2" (2426)	48" (1219)	96" (2438)	12.80 (1.19)	19 1/4" (489)	21 1/4" (540)	86 3/4" (2203)	13.76 (1.28)	14.29 (1.33)	36.60 (3.40)
5080	2	96" (2438)	90 13/16" (2307)	59 1/4" (1505)	95 1/2" (2426)	60" (1524)	96" (2438)	34.65 (3.22)	52 11/16" (1338)	56 5/8" (1438)	88 1/8" (2238)	20.50 (1.90)	42.47 (3.95)	45.67 (4.24)
5080	1	96" (2438)	90 13/16" (2307)	59 1/4" (1505)	95 1/2" (2426)	60" (1524)	96" (2438)	16.68 (1.55)	25 1/4" (641)	27 1/4" (692)	88 1/8" (2238)	20.50 (1.90)	18.15 (1.69)	45.67 (4.24)
5480	2	96" (2438)	90 1/8" (2289)	63 1/4" (1607)	95 1/2" (2426)	64" (1626)	96" (2438)	36.81 (3.42)	56 11/16" (1440)	60 5/8" (1540)	87 7/16" (2221)	22.61 (2.10)	45.24 (4.20)	48.51 (4.51)
5480	1	96" (2438)	90 1/8" (2289)	63 1/4" (1607)	95 1/2" (2426)	64" (1626)	96" (2438)	17.76 (1.65)	27 1/4" (692)	29 1/4" (743)	87 7/16" (2221)	22.61 (2.10)	19.35 (1.80)	48.51 (4.51)
6080	2	96" (2438)	88 5/8" (2251)	71 1/4" (1810)	95 1/2" (2426)	72" (1829)	96" (2438)	40.98 (3.81)	64 11/16" (1643)	68 5/8" (1743)	86" (2184)	26.78 (2.49)	50.73 (4.71)	54.14 (5.03)
6080	1	96" (2438)	88 5/8" (2251)	71 1/4" (1810)	95 1/2" (2426)	72" (1829)	96" (2438)	19.86 (1.84)	31 1/4" (794)	33 1/4" (845)	86" (2184)	26.78 (2.49)	21.74 (2.02)	54.14 (5.03)
6480	2	96" (2438)	87 13/16" (2230)	75 1/4" (1911)	95 1/2" (2426)	76" (1930)	96" (2438)	42.96 (3.99)	68 11/16" (1745)	72 5/8" (1845)	85 3/16" (2164)	28.83 (2.68)	57.33 (5.33)	60.95 (5.66)
6480	1	96" (2438)	87 13/16" (2230)	75 1/4" (1911)	95 1/2" (2426)	76" (1930)	96" (2438)	20.85 (1.94)	33 1/4" (845)	35 1/4" (895)	85 3/16" (2164)	28.83 (2.68)	25.22 (2.34)	60.95 (5.66)

* "Door Dimension" always refers to outside frame-to-frame dimension.
 * "Minimum Rough Opening" dimensions may need to be increased to allow for use of building wraps, flashing, sill panning, brackets, fasteners or other items. See pages 226-227 for more details.
 * Dimensions in parentheses are in millimeters or square meters.
 * For two-panel patio doors with one panel open, clear opening is based on active panel being open and passive panel being closed.

Complementary Arch Patio Door Sidelights

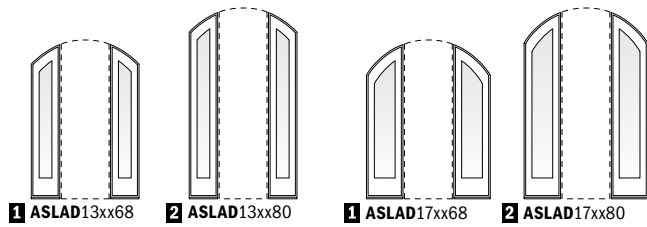

Custom sized in 1/8" (3) increments.

Standard sizes in two widths and heights. Contact your Andersen supplier for sidelight dimensions and specifications. Sash-set arch patio door sidelights, shown, are standard. Direct-set sidelights are available by special order.

Order Designation Description

Viewed from the exterior.

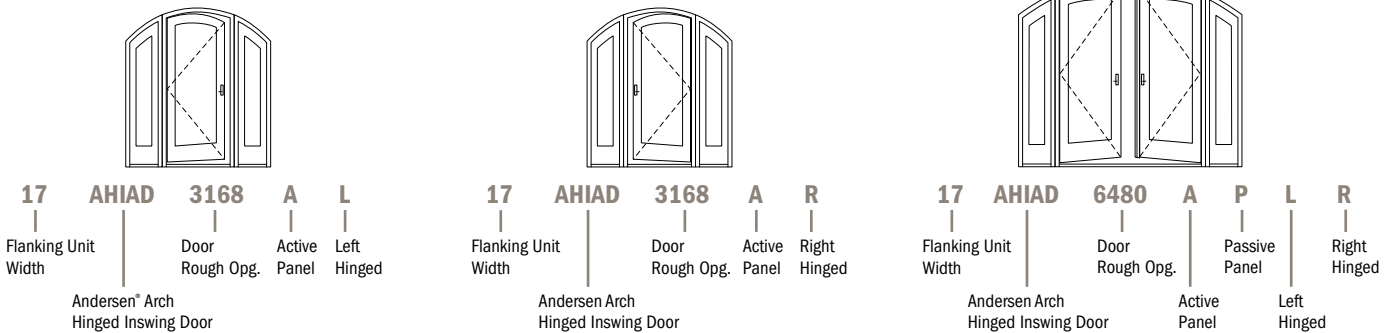

Arch inswing patio doors (AHIAAD) shown above; for arch outswing patio doors use AOAD. Outswing patio doors open outward to the exterior.

Complementary Arch Patio Door Sidelight Details

Scale 1 1/2" (38) = 1'-0" (305) – 1:8

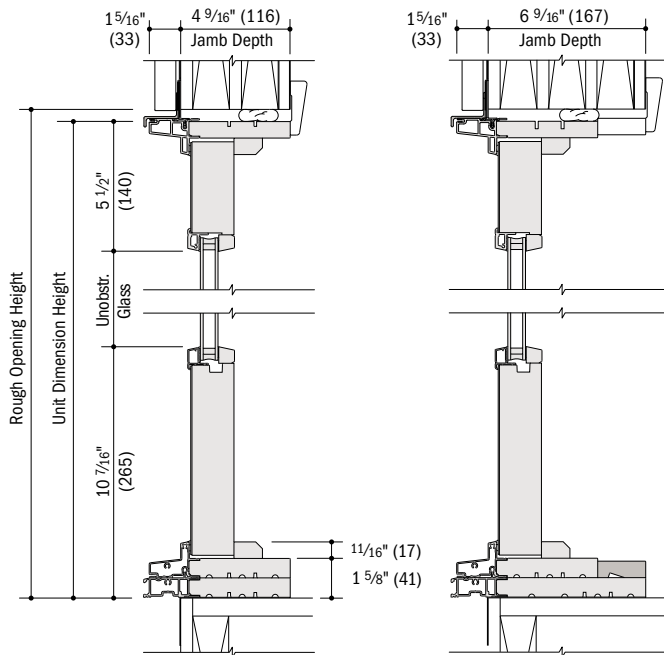

Vertical Sections

Vertical Joining Details

Scale 1 1/2" (38) = 1'-0" (305) – 1:8

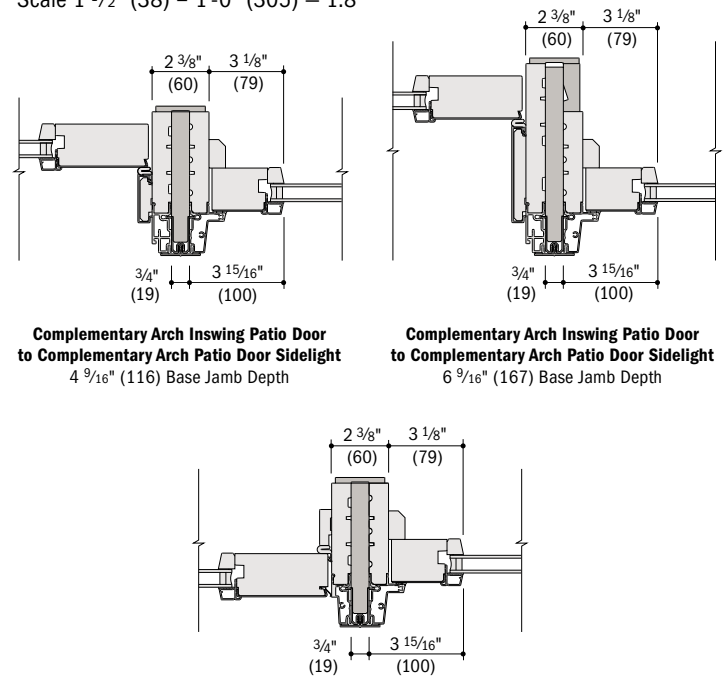

Complementary Arch Inswing Patio Door to Complementary Arch Patio Door Sidelight
4 9/16" (116) Base Jamb Depth

Complementary Arch Inswing Patio Door to Complementary Arch Patio Door Sidelight
6 9/16" (167) Base Jamb Depth

Complementary Arch Outswing Patio Door to Complementary Arch Patio Door Sidelight

- 4 9/16" (116) and 6 9/16" (167) overall jamb depth measurements are from back side of installation flange.
- Light-colored areas are parts included with window and/or door. Dark-colored areas are additional Andersen® parts required to complete window and/or door assembly as shown.
- **Minimum rough openings may need to be increased to allow for use of building wraps, flashing, sill panning, brackets, fasteners or other items. See installation information on pages 226-227.**
- Details are for illustration only and are not intended to represent product installation methods or materials. Refer to product installation guides at andersenwindows.com.
- Dimensions in parentheses are in millimeters.

A-Series Complementary Curved Top Patio Doors

COMPLEMENTARY CURVED TOP PATIO DOORS

Complementary Arch Hinged Inswing Patio Door Details – 4 9/16" (116) Base Jamb Depth

Scale 1 1/2" (38) = 1'-0" (305) – 1:8

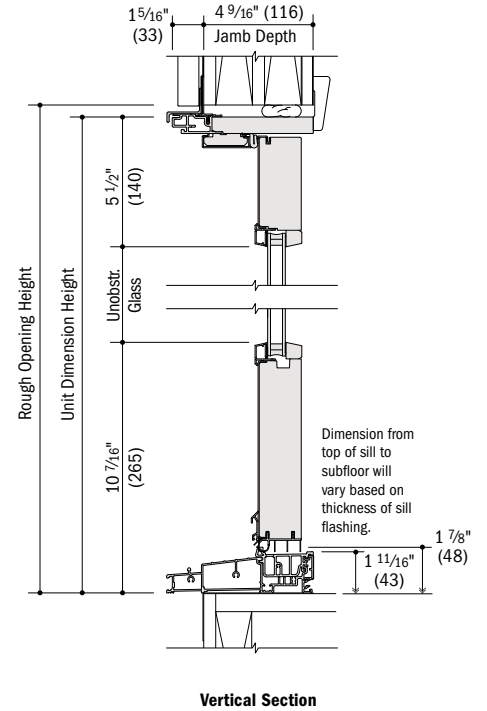
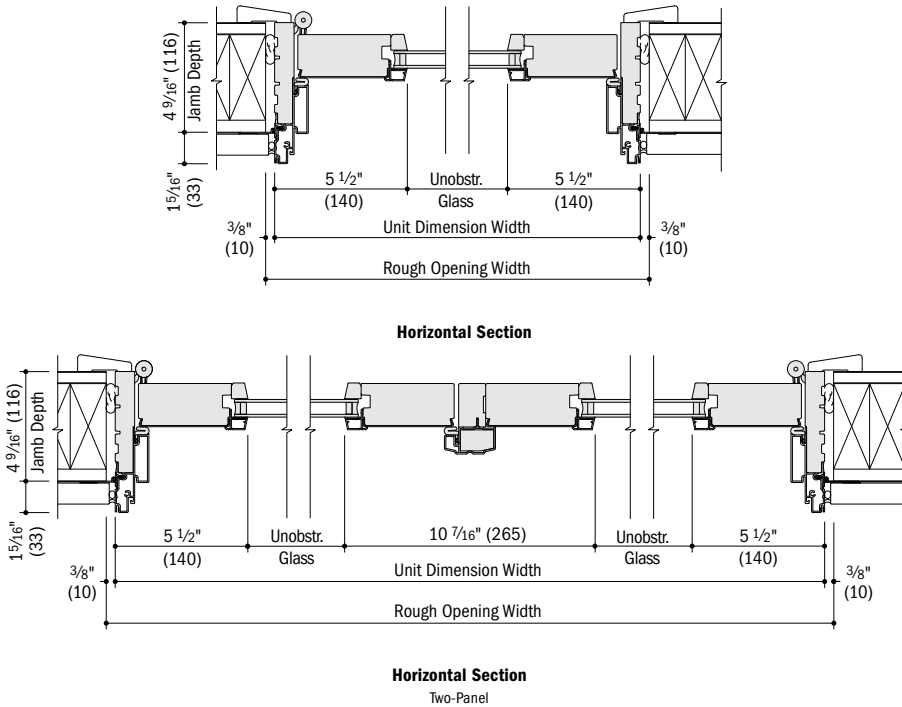

Complementary Arch Hinged Inswing Patio Door Details – 6 9/16" (167) Base Jamb Depth

Scale 1 1/2" (38) = 1'-0" (305) – 1:8

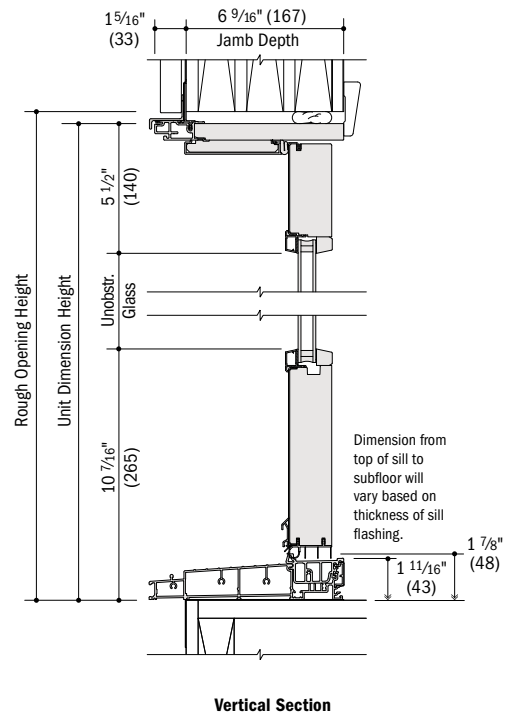
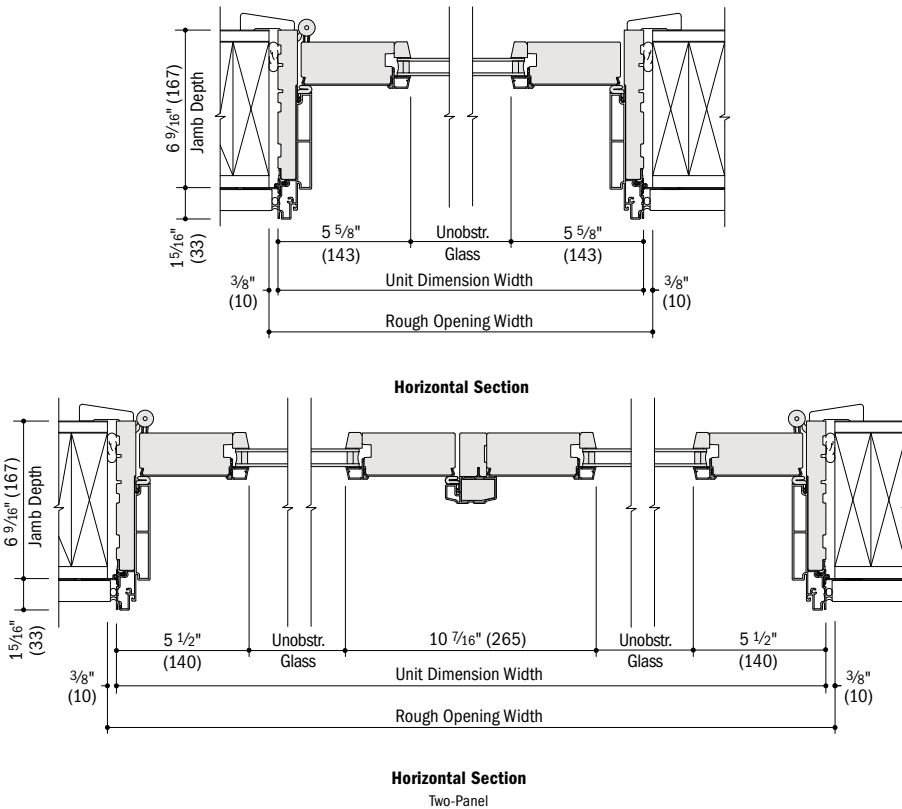

- 4 9/16" (116) and 6 9/16" (167) overall jamb depth measurements are from back side of installation flange.
- Light-colored areas are parts included with door. Dark-colored areas are additional Andersen® parts required to complete door assembly as shown.
- **Minimum rough openings may need to be increased to allow for use of building wraps, flashing, sill panning, brackets, fasteners or other items. See installation information on pages 226-227.**
- Details are for illustration only and are not intended to represent product installation methods or materials. Refer to product installation guides at andersenwindows.com.
- Dimensions in parentheses are in millimeters.

Complementary Arch Hinged Outswing Patio Door Details

Scale 1 1/2" (38) = 1'-0" (305) – 1:8

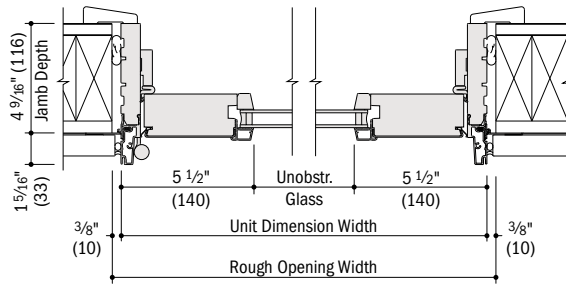

Horizontal Section

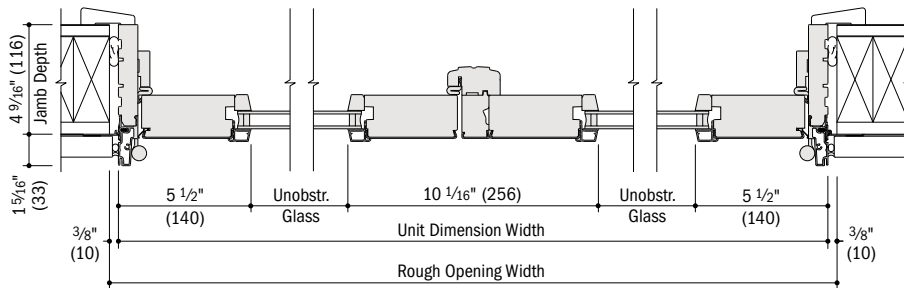

Horizontal Section

Two-Panel

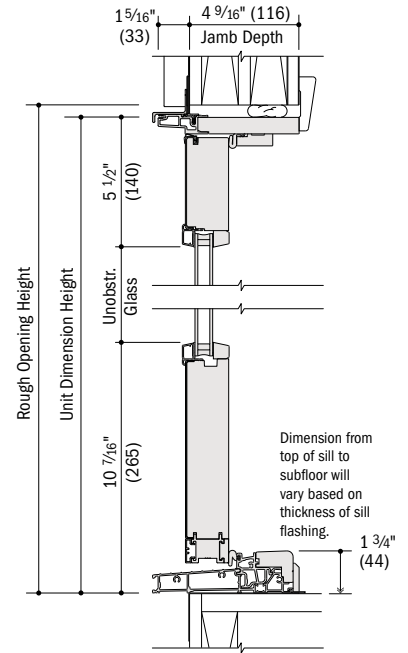

Vertical Section

A-Series
Complementary
Curved Top Patio Doors

- 4 9/16" (116) overall jamb depth measurement is from back side of installation flange.
- Light-colored areas are parts included with door. Dark-colored areas are additional Andersen® parts required to complete door assembly as shown.
- **Minimum rough openings may need to be increased to allow for use of building wraps, flashing, sill panning, brackets, fasteners or other items. See installation information on pages 226-227.**
- Details are for illustration only and are not intended to represent product installation methods or materials. Refer to product installation guides at andersenwindows.com.
- Dimensions in parentheses are in millimeters.

NOTES

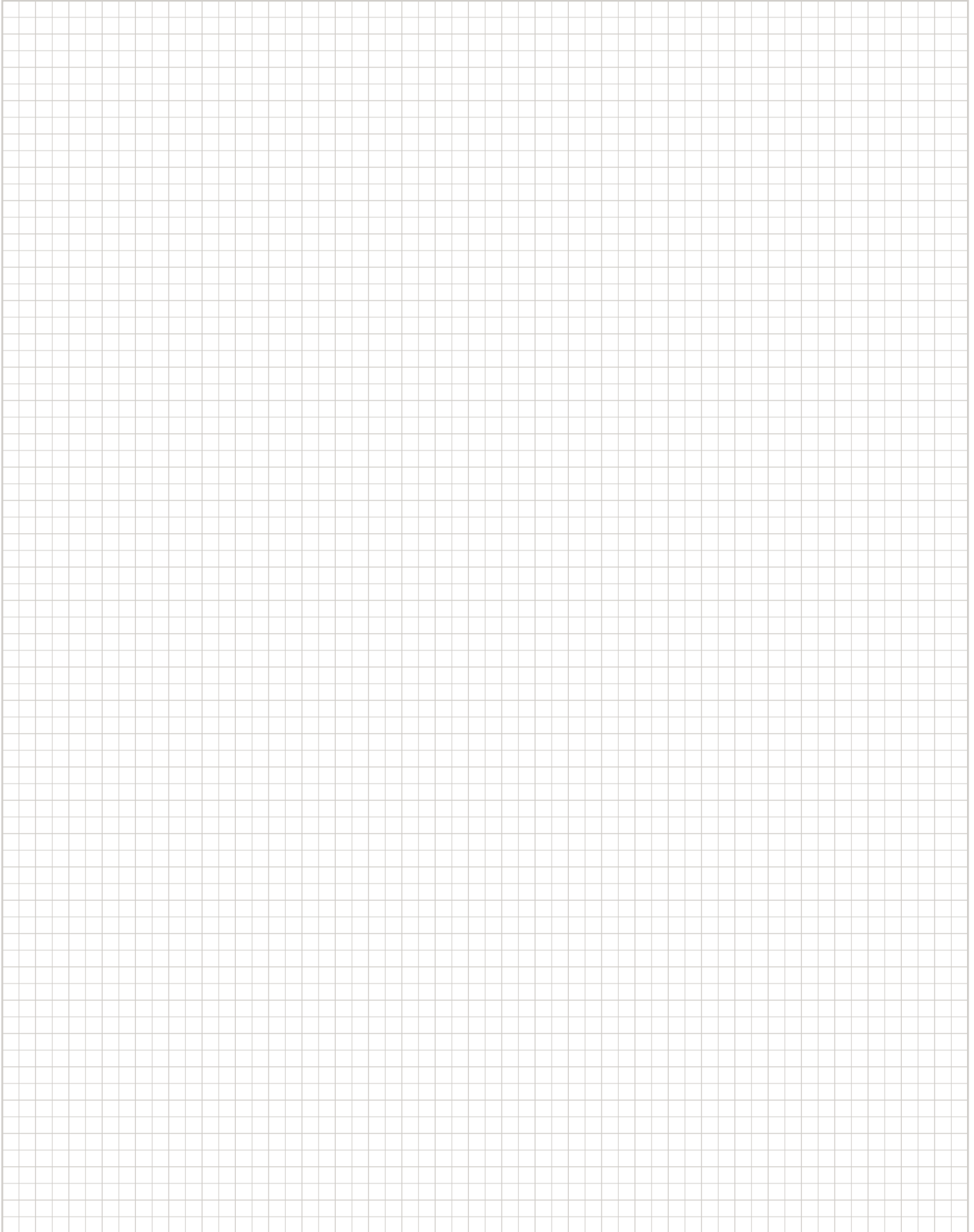



EXTERIOR TRIM

Flat Casing	192
Brick Mould	193
Sill Nose	193
Decorative Drip Cap	194
Cornices	194
Mull Cover	194

CUSTOM SIZING
in 1/8" (3) increments



Dimensions in parentheses are in millimeters.

EXTERIOR TRIM

FEATURES

EXTERIOR TRIM SYSTEM

Easier Installation

- Installs independently of water management system
- No nail holes to fill
- No visible fasteners
- No painting



Made of Fibrex® material that is an environmentally smart composite, containing 40% pre-consumer reclaimed wood fiber by weight.



EXTERIOR TRIM

- A** For exceptional long-lasting performance, exterior trim is made from Fibrex material or high-density urethane with low-maintenance exterior finishes.
- B** Sill nose profile, made from Fibrex material, is placed at the sill for a traditional look.
- C** Trim is securely fastened to the home using factory-applied trim flange or field applied attachment strips.
- D** Trim surrounds are assembled with corner keys and stainless steel fasteners for stability and strength.

Profiles

Exterior trim is available in four profiles made from our Fibrex material. Profiles include 3 1/2" (89) flat casing, 4 1/2" (114) flat casing, 2" (51) brick mould and a sill nose for the bottom trim piece. See profiles and sill options on the next page.

Thick trim profiles overlap the window frame to create clean lines without visible sealant joints.

Drip Cap

Full-length, color-matched aluminum drip cap is included with kits and surrounds.

End Caps

Provide a clean appearance when joining two trim members.

Corner Keys

Provide tight alignment of corner joints.

Fasteners

Screws are made of high-quality stainless steel and provide corner joints with a secure, tight fit.



Cocoa bean trim with Sandtone window shown above. White trim with white window in detail shown at right.

Design a window and view exterior trim installation guides at andersenwindows.com/exteriotrim.

Head Trim Options

Three styles are available. All can be used above our flat casing and include an integrated installation flange. The decorative drip cap is made from our Fibrex material. Both the 2" (51) cornice and 3 5/8" (92) cornice are made from highly durable urethane material. See head options on the next page.

Specialty Trim



Made of highly durable factory-finished urethane material for selected shapes. Contact your Andersen supplier for availability.

INSTALLATION OPTIONS

Preassembled Trim Surrounds

Factory-assembled surrounds install in seconds on A-Series windows with optional factory-applied exterior trim flange.

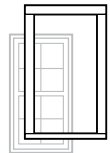

Precut Kits

Knock-down kits include precut and predrilled trim with all the necessary components for on-site assembly for windows and patio doors up to 12' (3658) in width or height.

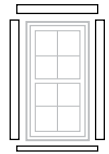

Individual Trim Components

13' (3962) factory-finished trim lineals, end caps, corner keys, fasteners, metal drip caps and field attachment strips allow for field fabrication and assembly.



EXTERIOR TRIM COLORS



*See the A-Series Limited Warranty for exterior trim applied to A-Series products. Visit andersenwindows.com/warranty for details.

Dimensions in parentheses are in millimeters.

Printing limitations prevent exact duplication of colors. See your Andersen supplier for actual color samples.

PROFILES



2" (51) Brick Mould in canvas with Sandtone window



3 1/2" (89) or 4 1/2" (114) Flat Casing in red rock with Sandtone window



3 1/2" (89) or 4 1/2" (114) Flat Casing in Terratone with Sandtone window

HEAD OPTIONS



Decorative Drip Cap over flat casing in forest green with Sandtone window



2" (51) Cornice over flat casing in prairie grass with Sandtone window



3 5/8" (92) Cornice over flat casing in white with Sandtone window

SILL OPTIONS



Sill nose and brick mould in Terratone with white window



Sill nose and flat casing in Terratone with red rock window



3 1/2" (89) or 4 1/2" (114) Flat Casing in white with white window

TRIM COMBINATIONS

Mix and match trim to create a variety of combinations. Not all sill combinations are shown. Contact your Andersen supplier for more information.

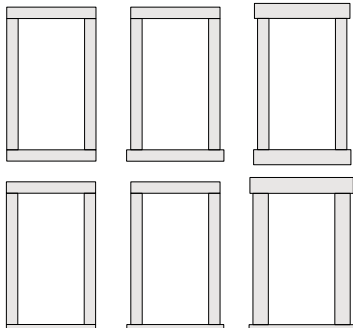

Flat Casing can be used on all four sides flush or extended at the head or sill. Combine 3 1/2" (89) and 4 1/2" (114) flat casing, or use with a flush or extended sill nose.

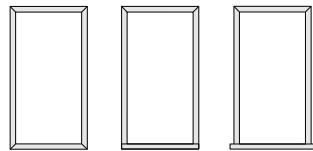

Brick Mould can be used on all four sides or with a flush or extended sill nose.

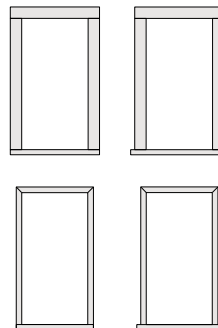

Sill Nose can be used with flat casing or brick mould. It can be applied flush or extended.

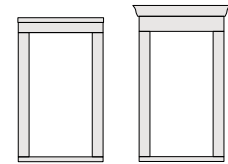

Decorative Drip Cap or **Cornice** can be used above flat casing at the head.

ACCESSORIES

INSTALLATION

Fibrex® Trim Board



Available in the same 11 colors as our exterior trim, this solid cellular Fibrex trim board can be cut or ripped to size, and can be fastened using nails or screws. 3 1/2" (89) x 3/4" (19) thick in 10' (3048) lengths.

Coil Stock

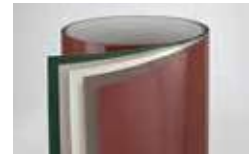

Andersen aluminum coil stock allows you to form your own profiles in the field and can be ordered to match any of our 11 exterior trim colors. Made from .018" thick aluminum, coil stock is available in 24" (610) x 50' (15240) rolls. Color-matched 1/4" (32)-long stainless steel trim nails are also available and can be ordered in 1 lb/454 kg boxes.

Exterior Trim

EXTERIOR TRIM

Window and Patio Door Attachment

Field-Applied Attachment Strip

Field-applied attachment strip fastens to framing through window or patio door installation flange and flashing tape with screws. Exterior trim connects securely to the field-applied attachment strip. Follow window and patio door installation guides for flashing instructions.

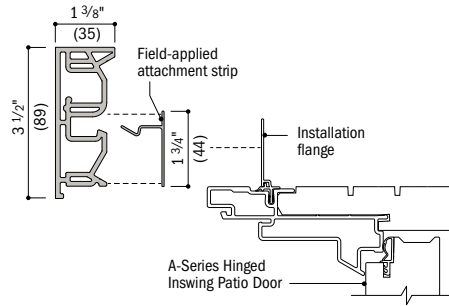

Factory-Applied Trim Flange

Factory-applied trim flanges are also available. Exterior trim connects securely to the trim flange already in place.

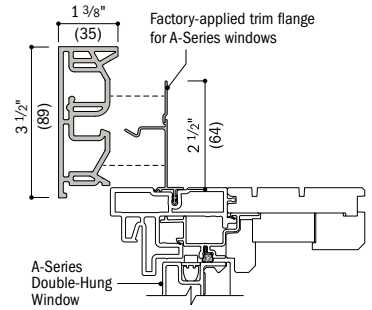

3 1/2" (89) Flat Casing and 4 1/2" (114) Flat Casing

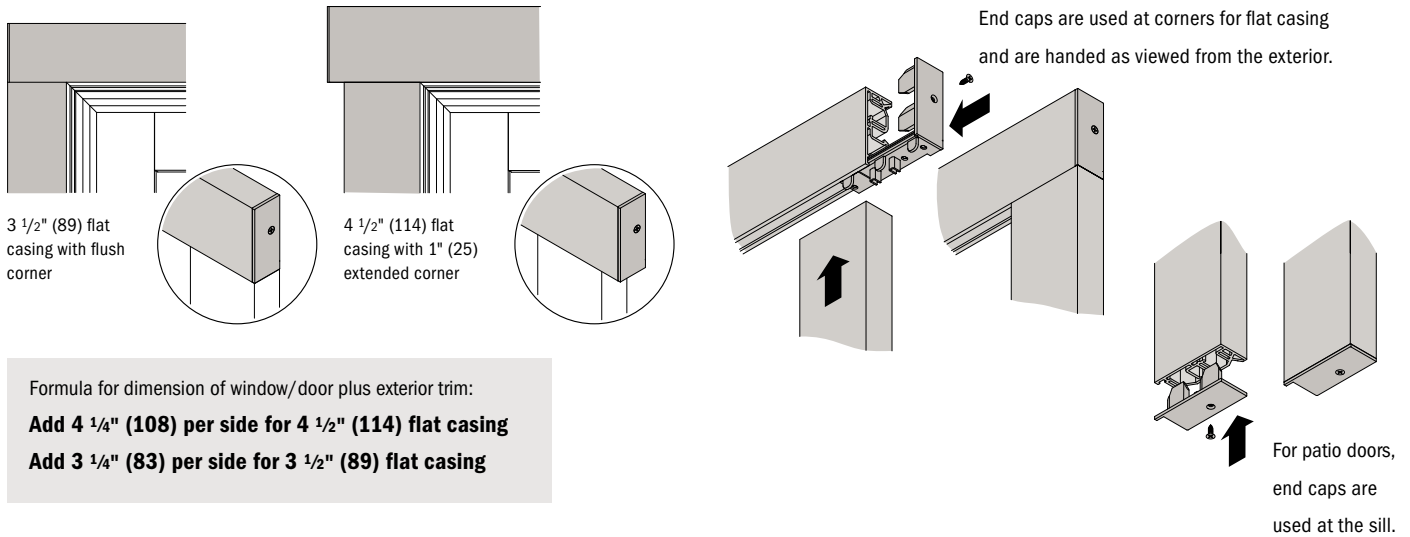

Formula for dimension of window/door plus exterior trim:
Add 4 1/4" (108) per side for 4 1/2" (114) flat casing
Add 3 1/4" (83) per side for 3 1/2" (89) flat casing

Trim Details

Scale 3" (76) = 1'-0" (305) – 1:4

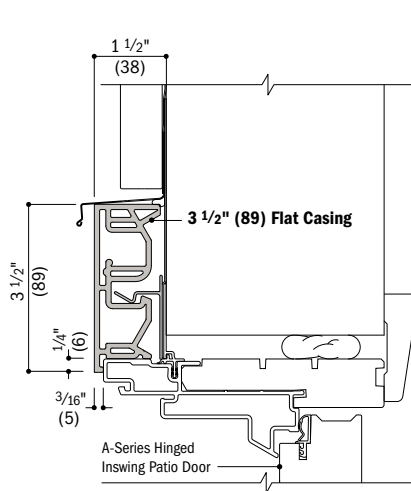

Vertical Section
A-Series Hinged Inswing Patio Door with 3 1/2" (89) Flat Casing

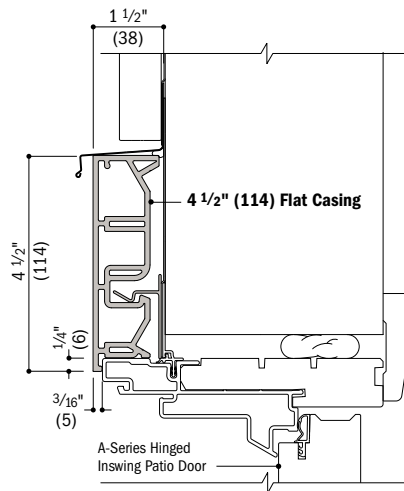

Vertical Section
A-Series Hinged Inswing Patio Door with 4 1/2" (114) Flat Casing

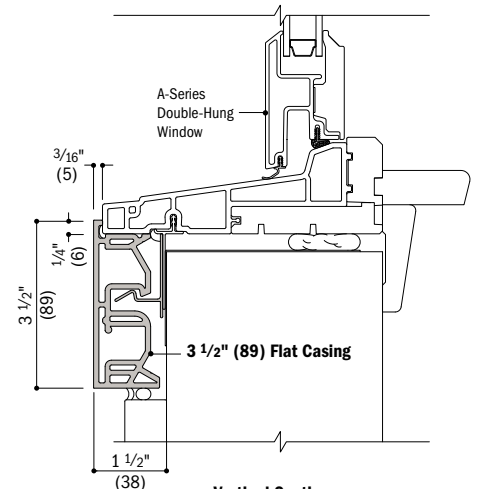

Vertical Section
A-Series Double-Hung Window with 3 1/2" (89) Flat Casing at Sill

• Typical trim combinations shown. Additional combinations may also be used. Some restrictions apply. Contact your Andersen supplier for more information.
 • Dimensions in parentheses are in millimeters.
 • Details are for illustration only and are not intended to represent product installation methods or materials. Refer to product installation instructions at andersenwindows.com.

Brick Mould

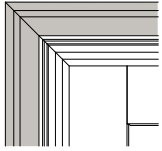

Brick mould with mitered corners

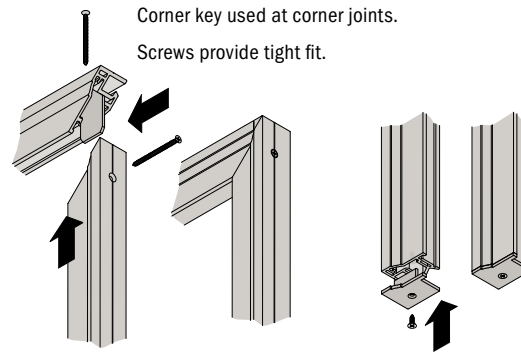

For patio doors, end caps are used at the sill.

Formula for dimension of window/door plus exterior trim:

Add 1 3/4" (44) per side for brick mould

Trim Details

Scale 3" (76) = 1'-0" (305) – 1:4

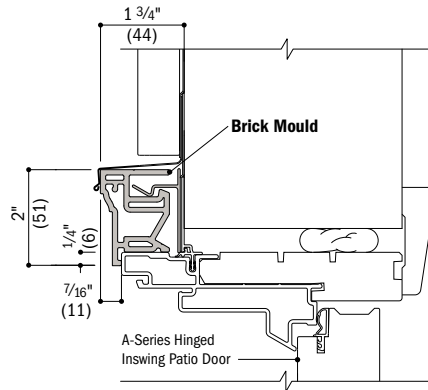

Vertical Section

A-Series Hinged Inswing Patio Door with Brick Mould

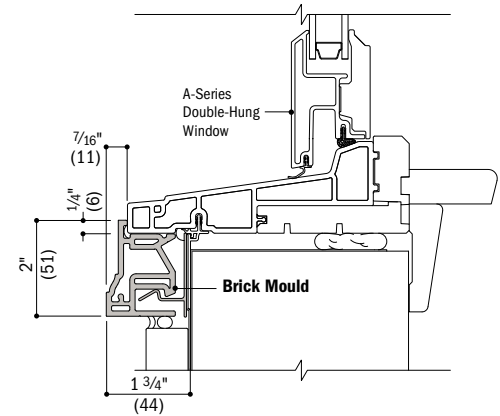

Vertical Section

A-Series Double-Hung Window with Brick Mould at Sill

Exterior Trim

Sill Nose

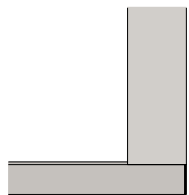

Sill nose and 3 1/2" (89) flat casing with flush corner

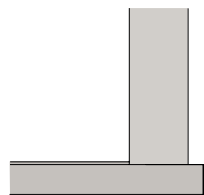
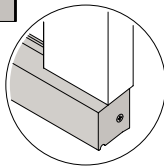

Sill nose and 3 1/2" (89) flat casing with 1" (25) extended corner

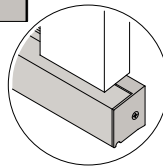

Formula for dimension of window plus exterior trim:

Add 1 15/16" (49) for sill nose

Trim Detail

Scale 3" (76) = 1'-0" (305) – 1:4

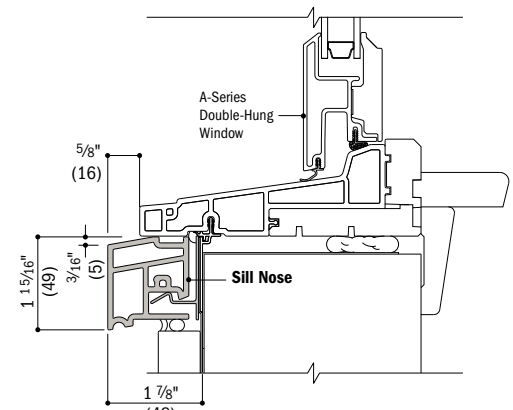

Vertical Section

A-Series Double-Hung Window with Sill Nose

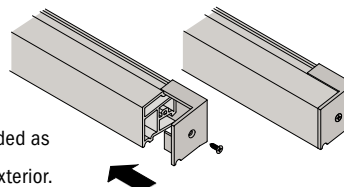

End caps are handed as viewed from the exterior.

*Typical trim combinations shown. Additional combinations may also be used. Some restrictions apply. Contact your Andersen supplier for more information.
 •Dimensions in parentheses are in millimeters.
 •Details are for illustration only and are not intended to represent product installation methods or materials. Refer to product installation instructions at andersenwindows.com.

EXTERIOR TRIM

Decorative Drip Cap

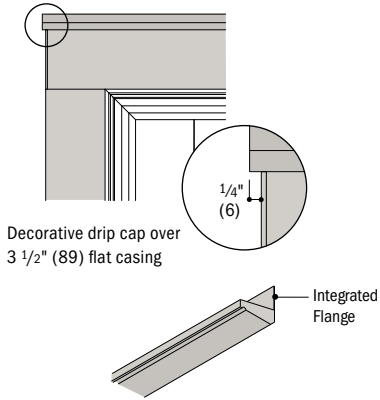

Cornices

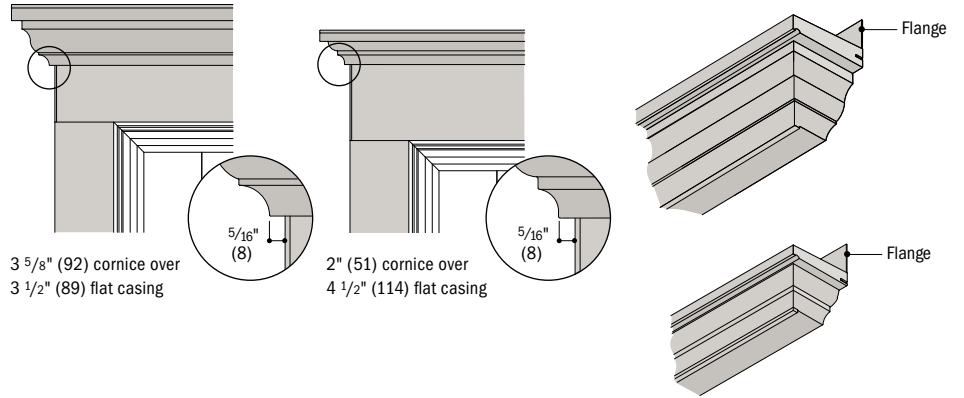

Trim Details

Scale 3" (76) = 1'-0" (305) – 1:4

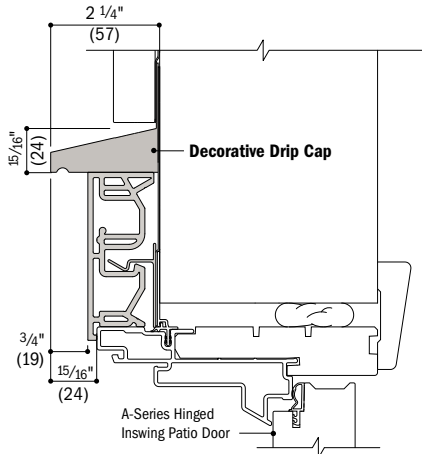

Vertical Section
A-Series Hinged Inswing Patio Door with Decorative Drip Cap Over 3 1/2" (89) Flat Casing

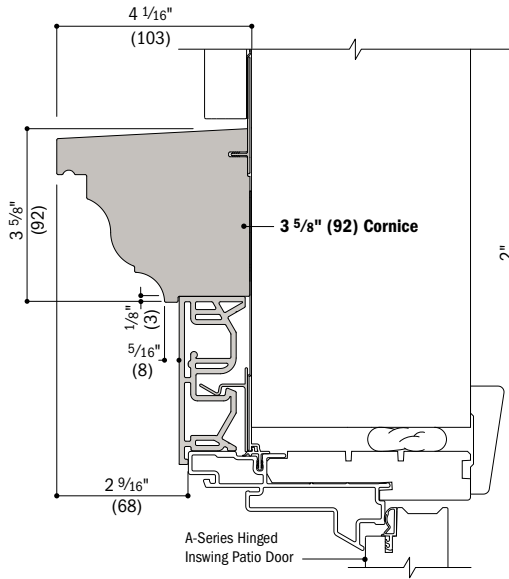

Vertical Section
A-Series Hinged Inswing Patio Door with 3 5/8" (92) Cornice Over 3 1/2" (89) Flat Casing

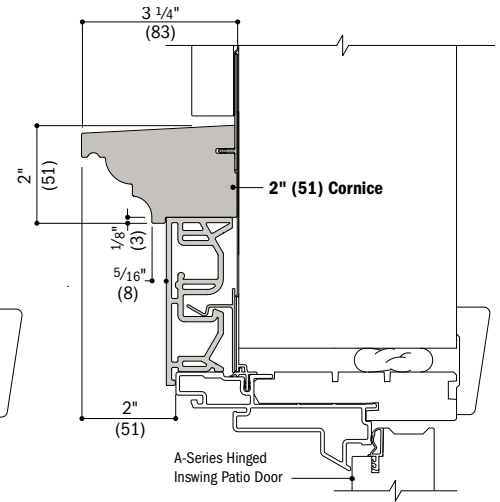

Vertical Section
A-Series Hinged Inswing Patio Door with 2" (51) Cornice Over 3 1/2" (89) Flat Casing

Mull Cover

3 5/8" (95) mull cover is available for installations where windows or patio doors have been installed into separate rough openings to obtain a joined appearance.

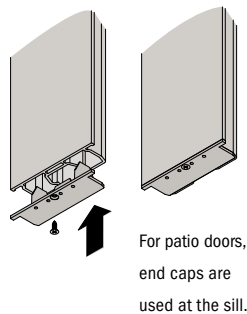

Separate Rough Opening Detail

Scale 3" (76) = 1'-0" (305) – 1:4

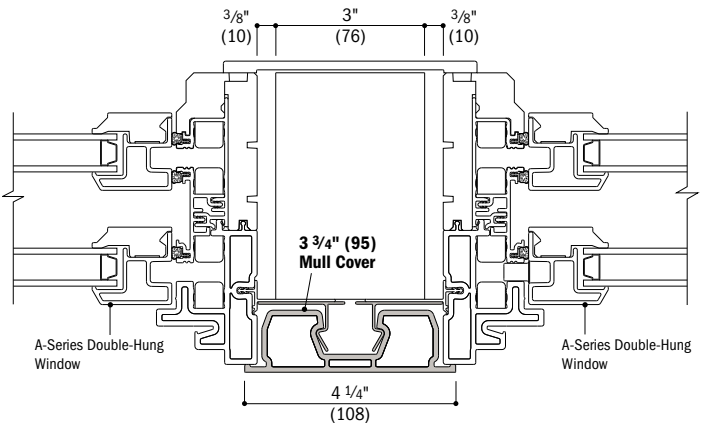

Horizontal Section
A-Series Double-Hung Windows and 3 3/4" (95) Mull Cover

- Typical trim combinations shown. Additional combinations may also be used. Some restrictions apply. Contact your Andersen supplier for more information.
- Dimensions in parentheses are in millimeters.
- Details are for illustration only and are not intended to represent product installation methods or materials. Refer to product installation instructions at andersenwindows.com.
- Consult with an architect or structural engineer regarding minimum requirements for structural support members between adjacent rough openings.

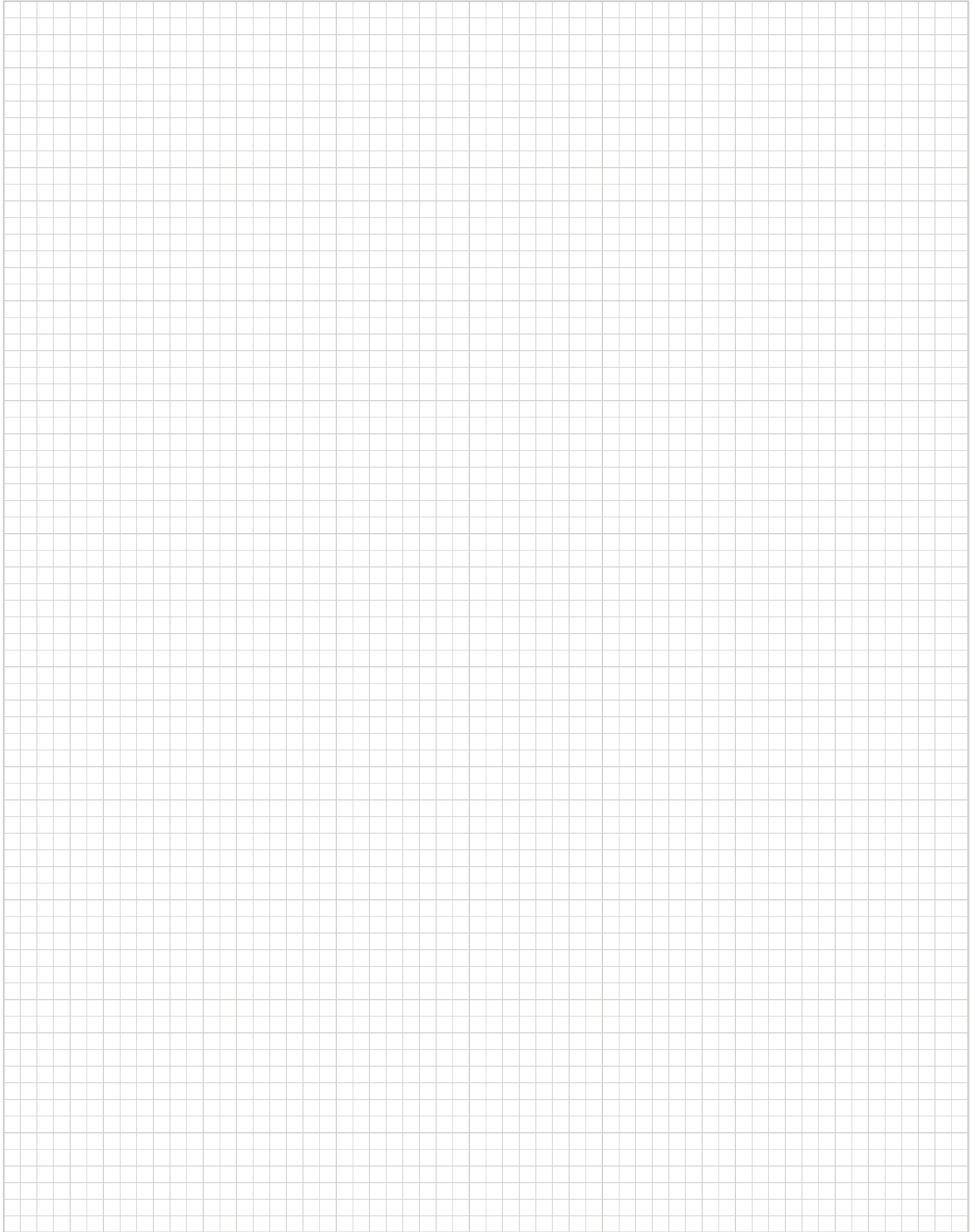

Andersen® windows and patio doors make it easy to create a wide variety of combination designs

Combination Types

Ribbons are horizontal window combinations (vertical joins) where opposite ends (head and sill) of individual windows are fastened to the building structure. Stacks are vertical window combinations (horizontal joins) where opposite sides (both side jambs) of individual windows are fastened to the building structure. One-way configurations or two-way configurations are used in combination designs.

One-Way



Ribbon Combination



Stack Combination

Two-Way



Multiple Ribbon/Stack Combination

Two-way combinations exist when multiple vertical stacks and horizontal ribbons are joined together. Unlike one-way combinations, the adjacent sides (head and sill, or both side jambs) of individual units are not necessarily fastened directly to the building structure. Two-way combinations are joined with both vertical and horizontal joining material, and may require reinforced joining materials and brackets depending on the local building code requirement for design wind load (measured in pounds per square foot, psf).

Determining Design Wind Load Performance

Proper combination design in conformance with local wind load requirements is vital to the success of your project. To make sure a combination is safe and that it complies with local building codes, the combination design wind load performance capacity must be determined. Correctly determining this performance capacity involves the following three steps:

STEP 1: Determine Building Code Requirement

Make sure you have the proper local codes and have identified specified compliance values. This calculated value (psf) will be used to determine if the combination will be acceptable (STEP 3).



STEP 2: Determine Product Performance

Compare product Design Pressure Rating data to the local building code (psf) requirement. This will show whether the individual units in a combination design are acceptable.



STEP 3: Determine Combination Performance

This step helps determine whether a given product, size, configuration and joining material type will meet the local building code design wind load requirement. To determine what joining material type to use (fiberglass, LVL or clips), compare the local building code design wind load requirement to the design wind load table value for a particular joining material on the following pages.

Andersen Joining Materials

For a successful installation, one engineered to provide the required design pressure, it is important Andersen joining materials and installation accessories be specified by a project architect or contractor. For one- and two-way combinations, Andersen offers a joining system to meet specified performance requirements. Patio door combinations are joined using fiberglass material. Window joining materials include fiberglass, Laminated Veneer Lumber (LVL) or clips. Each creates a joining system that enhances the look of Andersen products without sacrificing performance.

The addition of joining materials will affect the overall rough opening dimension; see page 226. **For all joining methods, read and follow product joining and installation instructions in their entirety. Visit andersenwindows.com for instructions.**

Exterior trim strips and trim strip end caps are included with each kit for finishing the exterior join. Interior casing is included with each window joining kit for finishing the join on the interior. Components used with each joining system will vary depending on products being joined. Check with your Andersen supplier for more information.

Reinforced joining material is used to create product alignment, positive joining and load transfer between Andersen windows and doors and the rough opening. They provide added strength capable of withstanding a greater range of wind load pressures. Non-reinforced joining material is used to create alignment and positive joining between windows. The structural performance of any combination is only as high as the lowest structural performance rating of any individual window or joining material in the combination.

Contact your Andersen supplier for specific performance and product recommendations.

Joining Materials

Easy Connect fiberglass joining material utilizes either 3/4" (19) x 5 3/4" (146) fiberglass interlocking joining plates for 4 9/16" (116) jamb depths or 3/4" (19) x 7 3/4" (197) fiberglass interlocking joining plates for higher performance for one-way and two-way joining, and is required for hinged inswing patio doors with 6 9/16" (167) jambs. For windows, the Easy Connect Joining System makes installation at the job site easier with smaller, factory-assembled sub-group combinations that join as they are installed in the rough opening. The innovative design eliminates the need to disassemble units prior to joining and provides higher performance. Also available for windows, fully joined combinations are factory assembled and arrive ready for installation in sizes up to 12' (3658) x 8' (2438) or 8' (2438) x 12' (3658). Joining kits for windows and patio doors include the necessary joining materials for individual units to be joined at the job site. Extension jamb kits are available for field-joined combinations. Extension jambs are available factory applied for factory-joined window combinations. In some situations, joining material may prohibit the application of perimeter extension jambs. For more information on fiberglass joining see page 20 or contact your Andersen supplier. Visit andersenwindow.com/joining to view an Easy Connect Joining System video.

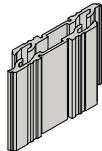
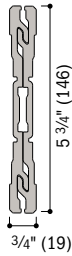

**3/4" (19) x 5 3/4" (146)
Easy Connect Fiberglass Joining Material**
For 4 9/16" (116) base jamb depths.

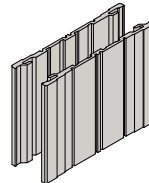
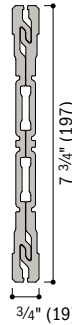

**3/4" (19) x 7 3/4" (197)
Easy Connect Fiberglass Joining Material**
For higher performance for 1-way and 2-way joining. Required for hinged inswing patio doors with 6 9/16" (167) or greater exterior extension jamb depths.

Laminated Veneer Lumber (LVL) joining materials with aluminum exterior trim receiver are used for factory-joined specialty-to-specialty window combinations only. Available for both 4 9/16" (116) and 6 9/16" (167) depths in lengths up to 10'-4" (3150).

Clips are mounted to the midpoint of the jambs being joined and are used for one-way (ribbon or stack) joining only. Clip joining includes a CPVC exterior trim receiver and foam insulation.

1-Way Clip Joining
A-Series Casement, Awning, Double-Hung, Picture, Transom, Specialty Windows*

Average Adjacent Window Dimension	(A + B) ÷ 2 = 10'-0" (3048)	63	42	32				
	(A + B) ÷ 2 = 9'-6" (2896)	63	42	32				
	(A + B) ÷ 2 = 9'-0" (2743)	63	42	32				
	(A + B) ÷ 2 = 8'-6" (2591)	63	42	32				
	(A + B) ÷ 2 = 8'-0" (2438)	63	42	32				
	(A + B) ÷ 2 = 7'-6" (2286)	63	42	32				
	(A + B) ÷ 2 = 7'-0" (2134)	63	42	32				
	(A + B) ÷ 2 = 6'-6" (1981)	63	42	32				
	(A + B) ÷ 2 = 6'-0" (1829)	63	42	32				
	(A + B) ÷ 2 = 5'-6" (1676)	63	42	33				
	(A + B) ÷ 2 = 5'-0" (1524)	63	43	34				
	(A + B) ÷ 2 = 4'-6" (1372)	65	45	35				
	(A + B) ÷ 2 = 4'-0" (1219)	67	47	37				
	(A + B) ÷ 2 = 3'-6" (1067)	70	51	41	31			
(A + B) ÷ 2 = 3'-0" (914)	70	55	44	33				
(A + B) ÷ 2 = 2'-6" (762)	70	64	52	39	33			
(A + B) ÷ 2 = 2'-0" (610)	70	70	60	45	38	30		
(A + B) ÷ 2 = 1'-6" (457)	70	70	70	60	50	40	34	
C = (length of join)	5'-6" (1676)	6'-0" (1829)	6'-6" (1981)	7'-0" (2134)	7'-6" (2286)	8'-0" (2438)	8'-6" (2591)	

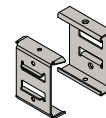
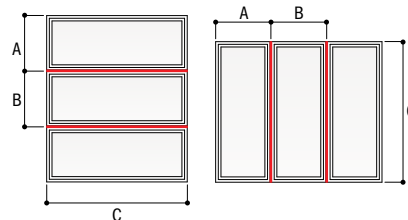

3/4" (19) Joining Clips

* Numerical values in charts represent structural pressure only.
 * Structural performance of any combination is only as high as the lowest structural performance of any individual unit or joining material in the combination.
 * Andersen® products must be installed and anchored properly according to joining and installation instructions to meet rated structural performance. Refer to product joining and installation instructions at andersenwindows.com.
 * Contact your Andersen supplier for joining windows to patio doors and for specific performance and product recommendations.
 * Dimensions in parentheses are in millimeters.
 * LVL joining material will be used for factory-joined specialty-to-specialty window combinations. See charts on pages 200-201.

Combination Designs,
Product Performance
& Installation

COMBINATION DESIGNS

1-Way Easy Connect Fiberglass Joining*

A-Series Casement, Awning, Double-Hung, Picture, Transom, Specialty Windows**

4 9/16" (116) Minimum Wall Depth	(A + B) ÷ 2 = 12'-0" (3658)	70	70	70	70	70	70	70	70	70	70	66	58	50
	(A + B) ÷ 2 = 11'-6" (3505)	70	70	70	70	70	70	70	70	70	70	66	58	50
	(A + B) ÷ 2 = 11'-0" (3353)	70	70	70	70	70	70	70	70	70	70	66	58	50
	(A + B) ÷ 2 = 10'-6" (3200)	70	70	70	70	70	70	70	70	70	70	66	58	50
	(A + B) ÷ 2 = 10'-0" (3048)	70	70	70	70	70	70	70	70	70	70	66	58	50
	(A + B) ÷ 2 = 9'-6" (2896)	70	70	70	70	70	70	70	70	70	70	66	58	50
	(A + B) ÷ 2 = 9'-0" (2743)	70	70	70	70	70	70	70	70	70	70	66	58	50
	(A + B) ÷ 2 = 8'-6" (2591)	70	70	70	70	70	70	70	70	70	70	66	58	50
	(A + B) ÷ 2 = 8'-0" (2438)	70	70	70	70	70	70	70	70	70	70	66	58	50
	(A + B) ÷ 2 = 7'-6" (2286)	70	70	70	70	70	70	70	70	70	70	66	58	50
	(A + B) ÷ 2 = 7'-0" (2134)	70	70	70	70	70	70	70	70	70	70	66	58	51
	(A + B) ÷ 2 = 6'-6" (1981)	70	70	70	70	70	70	70	70	70	70	67	59	52
	(A + B) ÷ 2 = 6'-0" (1829)	70	70	70	70	70	70	70	70	70	70	68	60	54
	(A + B) ÷ 2 = 5'-6" (1676)	70	70	70	70	70	70	70	70	70	70	69	62	56
	(A + B) ÷ 2 = 5'-0" (1524)	70	70	70	70	70	70	70	70	70	70	70	65	59
	(A + B) ÷ 2 = 4'-6" (1372)	70	70	70	70	70	70	70	70	70	70	70	69	63
	(A + B) ÷ 2 = 4'-0" (1219)	70	70	70	70	70	70	70	70	70	70	70	70	68
	(A + B) ÷ 2 = 3'-6" (1067)	70	70	70	70	70	70	70	70	70	70	70	70	70
	(A + B) ÷ 2 = 3'-0" (914)	70	70	70	70	70	70	70	70	70	70	70	70	70
	(A + B) ÷ 2 = 2'-6" (762)	70	70	70	70	70	70	70	70	70	70	70	70	70
(A + B) ÷ 2 = 2'-0" (610)	70	70	70	70	70	70	70	70	70	70	70	70	70	
(A + B) ÷ 2 = 1'-6" (457)	70	70	70	70	70	70	70	70	70	70	70	70	70	
C = (length of join)	2'-0" (610)	2'-6" (762)	3'-0" (914)	3'-6" (1067)	4'-0" (1219)	4'-6" (1372)	5'-0" (1524)	5'-6" (1676)	6'-0" (1829)	6'-6" (1981)	7'-0" (2134)	7'-6" (2286)	8'-0" (2438)	

continued on next page

2-Way Easy Connect Fiberglass Joining*

A-Series Casement, Awning, Double-Hung, Picture, Transom, Specialty Windows**

4 9/16" (116) Minimum Wall Depth	(A + B) ÷ 2 = 12'-0" (3658)	68	54	45	38	34	30							
	(A + B) ÷ 2 = 11'-6" (3505)	70	56	47	40	35	31							
	(A + B) ÷ 2 = 11'-0" (3353)	70	59	49	42	37	33							
	(A + B) ÷ 2 = 10'-6" (3200)	70	62	51	44	38	34	31						
	(A + B) ÷ 2 = 10'-0" (3048)	70	65	54	46	40	36	32						
	(A + B) ÷ 2 = 9'-6" (2896)	70	68	57	49	43	38	34	31					
	(A + B) ÷ 2 = 9'-0" (2743)	70	70	60	51	45	40	36	33	30				
	(A + B) ÷ 2 = 8'-6" (2591)	70	70	64	54	48	42	38	35	32				
	(A + B) ÷ 2 = 8'-0" (2438)	70	70	68	58	51	45	40	37	34	31			
	(A + B) ÷ 2 = 7'-6" (2286)	70	70	70	62	54	48	43	39	36	33	31		
	(A + B) ÷ 2 = 7'-0" (2134)	70	70	70	66	58	51	46	42	38	35	33	31	
	(A + B) ÷ 2 = 6'-6" (1981)	70	70	70	70	62	55	50	45	41	38	35	33	31
	(A + B) ÷ 2 = 6'-0" (1829)	70	70	70	70	68	60	54	49	45	41	38	36	33
	(A + B) ÷ 2 = 5'-6" (1676)	70	70	70	70	70	66	59	54	49	45	42	39	36
	(A + B) ÷ 2 = 5'-0" (1524)	70	70	70	70	70	70	65	59	54	50	46	43	40
	(A + B) ÷ 2 = 4'-6" (1372)	70	70	70	70	70	70	70	66	60	55	51	48	45
	(A + B) ÷ 2 = 4'-0" (1219)	70	70	70	70	70	70	70	70	68	62	58	54	50
	(A + B) ÷ 2 = 3'-6" (1067)	70	70	70	70	70	70	70	70	70	70	66	62	57
	(A + B) ÷ 2 = 3'-0" (914)	70	70	70	70	70	70	70	70	70	70	70	70	67
	(A + B) ÷ 2 = 2'-6" (762)	70	70	70	70	70	70	70	70	70	70	70	70	70
(A + B) ÷ 2 = 2'-0" (610)	70	70	70	70	70	70	70	70	70	70	70	70	70	
(A + B) ÷ 2 = 1'-6" (457)	70	70	70	70	70	70	70	70	70	70	70	70	70	
C = (length of join)	2'-0" (610)	2'-6" (762)	3'-0" (914)	3'-6" (1067)	4'-0" (1219)	4'-6" (1372)	5'-0" (1524)	5'-6" (1676)	6'-0" (1829)	6'-6" (1981)	7'-0" (2134)	7'-6" (2286)	8'-0" (2438)	

continued on next page

- * Numerical values in charts represent structural pressure only.
- * Structural performance of any combination is only as high as the lowest structural performance of any individual unit or joining material in the combination.
- * Easy Connect and other fiberglass joins are certified up to PG70 when installed according to Andersen installation instructions.
- * Andersen products must be installed and anchored properly according to joining and installation instructions to meet rated structural performance. Refer to product joining and installation instructions at andersenwindows.com.
- * Dimensions in parentheses are in millimeters.
- * Contact your Andersen supplier for joining windows to patio doors and for specific performance and product recommendations.
- * Fixed transom windows (ATF) can only be joined to venting transoms windows (ATV) vertically and double-hung windows (ADH) can only be joined to double-hung windows (ADH) vertically. For "T" combinations not found in iQ+, contact your Andersen supplier.
- ** LVL joining material will be used for factory-joined specialty-to-specialty window combinations. See charts on pages 200-201.

1-Way Easy Connect Fiberglass Joining continued from previous page

42	35	30					
42	35	30					
42	35	30					
42	35	30					
42	35	30					
42	35	30					
42	35	30					
42	35	30					
42	35	30					
42	36	31					
43	37	32					
44	38	33					
45	39	34	30				
47	41	36	31				
50	44	39	33				
54	47	42	36	31			
58	51	46	39	34			
62	57	50	43	37	32		
69	64	57	49	42	36	32	
70	70	66	56	48	42	37	32
70	70	70	67	58	50	44	38
70	70	70	70	70	62	54	48
70	70	70	70	70	70	70	63
8'-6" (2591)	9'-0" (2743)	9'-6" (2896)	10'-0" (3048)	10'-6" (3200)	11'-0" (3353)	11'-6" (3505)	12'-0" (3658)

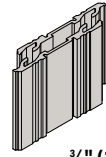
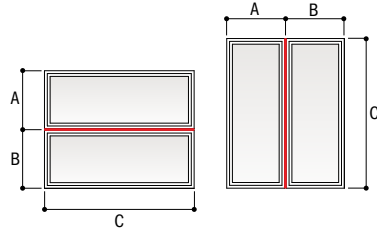

3/4" (19) x 5 3/4" (146)
Easy Connect Fiberglass Joining Material
For 4 7/16" (116) base jamb depths.

Combination Designs,
Product Performance
& Installation

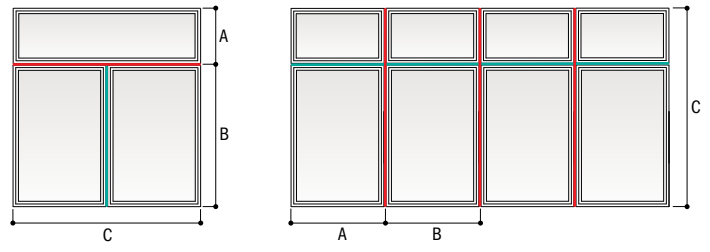

Red lines represent priority joint (dimension C in table).

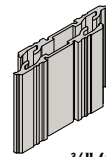

3/4" (19) x 5 3/4" (146)
Easy Connect Fiberglass Joining Material
For 4 7/16" (116) base jamb depths.

2-Way Easy Connect Fiberglass Joining continued from previous page

32							
35	32						
39	35	31					
44	40	35	32				
51	45	41	37	33	30		
59	53	47	43	39	35	32	30
70	64	57	51	47	42	39	36
70	70	70	64	58	53	49	45
70	70	70	70	70	70	65	60
8'-6" (2591)	9'-0" (2743)	9'-6" (2896)	10'-0" (3048)	10'-6" (3200)	11'-0" (3353)	11'-6" (3505)	12'-0" (3658)

- Numerical values in charts represent structural pressure only.
- Structural performance of any combination is only as high as the lowest structural performance of any individual unit or joining material in the combination.
- Easy Connect and other fiberglass joins are certified up to PG70 when installed according to Andersen installation instructions.
- Andersen® products must be installed and anchored properly according to joining and installation instructions to meet rated structural performance. Refer to product joining and installation instructions at andersenwindows.com.
- Dimensions in parentheses are in millimeters.
- Contact your Andersen supplier for joining windows to patio doors and for specific performance and product recommendations.
- Fixed transom windows (ATF) can only be joined to venting transoms windows (ATV) vertically and double-hung windows (ADH) can only be joined to double-hung windows (ADH) vertically. For "T" combinations not found in iQ+, contact your Andersen supplier.
- **LVL joining material will be used for factory-joined specialty-to-specialty window combinations. See charts on pages 200-201.

COMBINATION DESIGNS

1-Way LVL Joining

A-Series Factory-Joined Specialty Windows

4 9/16" (116) Minimum Wall Depth	Average Adjacent Window Dimension	(A + B) ÷ 2 = 10'-0" (3048)	70	70	70	55	44	33				
		(A + B) ÷ 2 = 9'-6" (2896)	70	70	70	55	44	33				
		(A + B) ÷ 2 = 9'-0" (2743)	70	70	70	55	44	33				
		(A + B) ÷ 2 = 8'-6" (2591)	70	70	70	55	44	33				
		(A + B) ÷ 2 = 8'-0" (2438)	70	70	70	55	44	33				
		(A + B) ÷ 2 = 7'-6" (2286)	70	70	70	55	44	33				
		(A + B) ÷ 2 = 7'-0" (2134)	70	70	70	55	44	33				
		(A + B) ÷ 2 = 6'-6" (1981)	70	70	70	56	45	34				
		(A + B) ÷ 2 = 6'-0" (1829)	70	70	70	56	45	35				
		(A + B) ÷ 2 = 5'-6" (1676)	70	70	70	58	47	36	30			
		(A + B) ÷ 2 = 5'-0" (1524)	70	70	70	60	49	38	32			
		(A + B) ÷ 2 = 4'-6" (1372)	70	70	70	64	52	40	34			
		(A + B) ÷ 2 = 4'-0" (1219)	70	70	70	67	55	43	36			
		(A + B) ÷ 2 = 3'-6" (1067)	70	70	70	70	61	48	41	33		
		(A + B) ÷ 2 = 3'-0" (914)	70	70	70	70	67	53	45	36	31	
		(A + B) ÷ 2 = 2'-6" (762)	70	70	70	70	70	62	53	43	37	31
		(A + B) ÷ 2 = 2'-0" (610)	70	70	70	70	70	70	62	50	44	36
		(A + B) ÷ 2 = 1'-6" (457)	70	70	70	70	70	70	70	67	59	49
		C = (length of join)	5'-6" (1676)	6'-0" (1829)	6'-6" (1981)	7'-0" (2134)	7'-6" (2286)	8'-0" (2438)	8'-6" (2591)	9'-0" (2743)	9'-6" (2896)	10'-0" (3048)

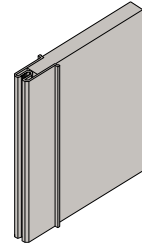
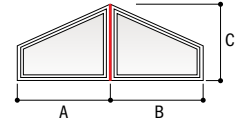

3/4" (19) x 5 3/4" (146) LVL Joining Material
For 4 9/16" (116) base jamb depths.

1-Way LVL Joining

A-Series Factory-Joined Specialty Windows

6 9/16" (167) Minimum Wall Depth	Average Adjacent Window Dimension	(A + B) ÷ 2 = 10'-0" (3048)	70	70	70	70	70	66	54	42	35	
		(A + B) ÷ 2 = 9'-6" (2896)	70	70	70	70	70	66	54	42	35	
		(A + B) ÷ 2 = 9'-0" (2743)	70	70	70	70	70	66	54	42	35	
		(A + B) ÷ 2 = 8'-6" (2591)	70	70	70	70	70	66	54	42	35	
		(A + B) ÷ 2 = 8'-0" (2438)	70	70	70	70	70	66	54	42	36	
		(A + B) ÷ 2 = 7'-6" (2286)	70	70	70	70	70	67	55	43	36	
		(A + B) ÷ 2 = 7'-0" (2134)	70	70	70	70	70	67	56	44	37	
		(A + B) ÷ 2 = 6'-6" (1981)	70	70	70	70	70	69	57	45	39	
		(A + B) ÷ 2 = 6'-0" (1829)	70	70	70	70	70	70	59	47	40	
		(A + B) ÷ 2 = 5'-6" (1676)	70	70	70	70	70	70	62	49	42	
		(A + B) ÷ 2 = 5'-0" (1524)	70	70	70	70	70	70	65	52	44	
		(A + B) ÷ 2 = 4'-6" (1372)	70	70	70	70	70	70	70	56	48	40
		(A + B) ÷ 2 = 4'-0" (1219)	70	70	70	70	70	70	70	60	52	42
		(A + B) ÷ 2 = 3'-6" (1067)	70	70	70	70	70	70	70	67	58	48
		(A + B) ÷ 2 = 3'-0" (914)	70	70	70	70	70	70	70	70	64	53
		(A + B) ÷ 2 = 2'-6" (762)	70	70	70	70	70	70	70	70	70	63
		(A + B) ÷ 2 = 2'-0" (610)	70	70	70	70	70	70	70	70	70	70
		(A + B) ÷ 2 = 1'-6" (457)	70	70	70	70	70	70	70	70	70	70
		C = (length of join)	5'-6" (1676)	6'-0" (1829)	6'-6" (1981)	7'-0" (2134)	7'-6" (2286)	8'-0" (2438)	8'-6" (2591)	9'-0" (2743)	9'-6" (2896)	10'-0" (3048)

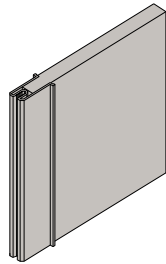
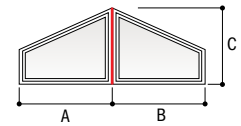

3/4" (19) x 7 3/4" (197) LVL Joining Material
For 6 9/16" (167) base jamb depths.

- Numerical values in charts represent structural pressure only.
- Structural performance of any combination is only as high as the lowest structural performance of any individual unit or joining material in the combination.
- Andersen® products must be installed and anchored properly according to joining and installation instructions to meet rated structural performance. Refer to product joining and installation instructions at andersenwindows.com.
- Dimensions in parentheses are in millimeters.
- Contact your Andersen supplier for joining windows to patio doors and for specific performance and product recommendations.

2-Way LVL Joining

A-Series Windows: Factory-Joined Specialty

4 9/16" (116) Minimum Wall Depth	Average Adjacent Window Dimension	(A + B) ÷ 2 = 6'-6" (1981)	42	31											
		(A + B) ÷ 2 = 6'-0" (1829)	45	33											
		(A + B) ÷ 2 = 5'-6" (1676)	50	37	30										
		(A + B) ÷ 2 = 5'-0" (1524)	54	40	32										
		(A + B) ÷ 2 = 4'-6" (1372)	61	45	37										
		(A + B) ÷ 2 = 4'-0" (1219)	67	49	40	31									
		(A + B) ÷ 2 = 3'-6" (1067)	70	58	47	36	31								
		(A + B) ÷ 2 = 3'-0" (914)	70	65	54	41	35								
		(A + B) ÷ 2 = 2'-6" (762)	70	70	66	51	43	34							
		(A + B) ÷ 2 = 2'-0" (610)	70	70	70	61	52	41	35						
		(A + B) ÷ 2 = 1'-6" (457)	70	70	70	70	70	57	49	40	35				
		C = (length of join)	5'-6" (1676)	6'-0" (1829)	6'-6" (1981)	7'-0" (2134)	7'-6" (2286)	8'-0" (2438)	8'-6" (2591)	9'-0" (2743)	9'-6" (2896)				

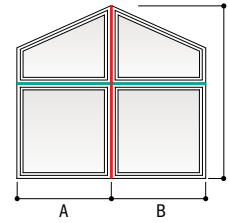

Red lines represent priority join (dimension C in table).

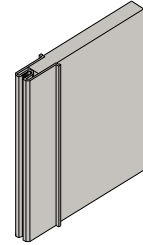

3/4" (19) x 5 3/4" (146) LVL Joining Material

For 4 9/16" (116) base jamb depths.

2-Way LVL Joining

A-Series Windows: Factory-Joined Specialty

6 9/16" (167) Minimum Wall Depth	Average Adjacent Window Dimension	(A + B) ÷ 2 = 10'-0" (3048)	69	49	40	31									
		(A + B) ÷ 2 = 9'-6" (2896)	70	52	42	33									
		(A + B) ÷ 2 = 9'-0" (2743)	70	54	44	34									
		(A + B) ÷ 2 = 8'-6" (2591)	70	58	47	37	31								
		(A + B) ÷ 2 = 8'-0" (2438)	70	61	50	38	32								
		(A + B) ÷ 2 = 7'-6" (2286)	70	65	54	41	35								
		(A + B) ÷ 2 = 7'-0" (2134)	70	69	57	44	37								
		(A + B) ÷ 2 = 6'-6" (1981)	70	70	62	48	40	32							
		(A + B) ÷ 2 = 6'-0" (1829)	70	70	66	51	43	34	30						
		(A + B) ÷ 2 = 5'-6" (1676)	70	70	70	56	48	38	33						
		(A + B) ÷ 2 = 5'-0" (1524)	70	70	70	61	51	41	35						
		(A + B) ÷ 2 = 4'-6" (1372)	70	70	70	69	58	46	40	33					
		(A + B) ÷ 2 = 4'-0" (1219)	70	70	70	70	64	51	44	36	32				
		(A + B) ÷ 2 = 3'-6" (1067)	70	70	70	70	70	59	51	42	37	31			
		(A + B) ÷ 2 = 3'-0" (914)	70	70	70	70	70	67	58	48	42	35			
		(A + B) ÷ 2 = 2'-6" (762)	70	70	70	70	70	80	71	59	51	43			
		(A + B) ÷ 2 = 2'-0" (610)	70	70	70	70	70	80	80	70	62	52			
		(A + B) ÷ 2 = 1'-6" (457)	70	70	70	70	70	80	80	80	70	70			
C = (length of join)	5'-6" (1676)	6'-0" (1829)	6'-6" (1981)	7'-0" (2134)	7'-6" (2286)	8'-0" (2438)	8'-6" (2591)	9'-0" (2743)	9'-6" (2896)	10'-0" (3048)					

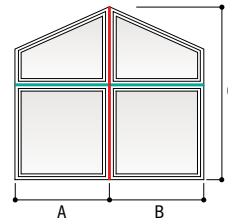

Red lines represent priority join (dimension C in table).

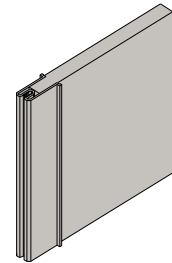

3/4" (19) x 7 3/4" (197) LVL Joining Material

For 6 9/16" (167) base jamb depths.

Combination Designs,
Product Performance
& Installation

- Numerical values in charts represent structural pressure only.
- Structural performance of any combination is only as high as the lowest structural performance of any individual unit or joining material in the combination.
- Andersen® products must be installed and anchored properly according to joining and installation instructions to meet rated structural performance. Refer to product joining and installation instructions at andersenwindows.com.
- Dimensions in parentheses are in millimeters.
- Contact your Andersen supplier for joining windows to patio doors and for specific performance and product recommendations.

COMBINATION DESIGNS

1-Way Easy Connect Fiberglass Joining

A-Series Gliding and Hinged Patio Doors, Sidelights and Transoms

4 9/16" (116) Minimum Wall Depth	Average Adjacent Window Dimension	(A + B) ÷ 2 = 12'-0" (3658)	70	70	70	70	70	70	70	70	70	70	70	70	67	
		(A + B) ÷ 2 = 11'-6" (3505)	70	70	70	70	70	70	70	70	70	70	70	70	70	67
		(A + B) ÷ 2 = 11'-0" (3353)	70	70	70	70	70	70	70	70	70	70	70	70	70	67
		(A + B) ÷ 2 = 10'-6" (3200)	70	70	70	70	70	70	70	70	70	70	70	70	70	67
		(A + B) ÷ 2 = 10'-0" (3048)	70	70	70	70	70	70	70	70	70	70	70	70	70	67
		(A + B) ÷ 2 = 9'-6" (2896)	70	70	70	70	70	70	70	70	70	70	70	70	70	67
		(A + B) ÷ 2 = 9'-0" (2743)	70	70	70	70	70	70	70	70	70	70	70	70	70	67
		(A + B) ÷ 2 = 8'-6" (2591)	70	70	70	70	70	70	70	70	70	70	70	70	70	67
		(A + B) ÷ 2 = 8'-0" (2438)	70	70	70	70	70	70	70	70	70	70	70	70	70	67
		(A + B) ÷ 2 = 7'-6" (2286)	70	70	70	70	70	70	70	70	70	70	70	70	70	67
		(A + B) ÷ 2 = 7'-0" (2134)	70	70	70	70	70	70	70	70	70	70	70	70	70	68
		(A + B) ÷ 2 = 6'-6" (1981)	70	70	70	70	70	70	70	70	70	70	70	70	70	70
		(A + B) ÷ 2 = 6'-0" (1829)	70	70	70	70	70	70	70	70	70	70	70	70	70	70
		(A + B) ÷ 2 = 5'-6" (1676)	70	70	70	70	70	70	70	70	70	70	70	70	70	70
		(A + B) ÷ 2 = 5'-0" (1524)	70	70	70	70	70	70	70	70	70	70	70	70	70	70
		(A + B) ÷ 2 = 4'-6" (1372)	70	70	70	70	70	70	70	70	70	70	70	70	70	70
		(A + B) ÷ 2 = 4'-0" (1219)	70	70	70	70	70	70	70	70	70	70	70	70	70	70
		(A + B) ÷ 2 = 3'-6" (1067)	70	70	70	70	70	70	70	70	70	70	70	70	70	70
		(A + B) ÷ 2 = 3'-0" (914)	70	70	70	70	70	70	70	70	70	70	70	70	70	70
		(A + B) ÷ 2 = 2'-6" (762)	70	70	70	70	70	70	70	70	70	70	70	70	70	70
		(A + B) ÷ 2 = 2'-0" (610)	70	70	70	70	70	70	70	70	70	70	70	70	70	70
		(A + B) ÷ 2 = 1'-6" (457)	70	70	70	70	70	70	70	70	70	70	70	70	70	70
		C = (length of join)	2'-0" (610)	2'-6" (762)	3'-0" (914)	3'-6" (1067)	4'-0" (1219)	4'-6" (1372)	5'-0" (1524)	5'-6" (1676)	6'-0" (1829)	6'-6" (1981)	7'-0" (2134)	7'-6" (2286)	8'-0" (2438)	

continued on next page

1-Way Easy Connect Fiberglass Joining

A-Series Gliding and Hinged Patio Doors, Sidelights and Transoms

6 9/16" (167) Minimum Wall Depth	Average Adjacent Window Dimension	(A + B) ÷ 2 = 12'-0" (3658)	70	70	70	70	70	70	70	70	70	70	70	70	70	
		(A + B) ÷ 2 = 11'-6" (3505)	70	70	70	70	70	70	70	70	70	70	70	70	70	70
		(A + B) ÷ 2 = 11'-0" (3353)	70	70	70	70	70	70	70	70	70	70	70	70	70	70
		(A + B) ÷ 2 = 10'-6" (3200)	70	70	70	70	70	70	70	70	70	70	70	70	70	70
		(A + B) ÷ 2 = 10'-0" (3048)	70	70	70	70	70	70	70	70	70	70	70	70	70	70
		(A + B) ÷ 2 = 9'-6" (2896)	70	70	70	70	70	70	70	70	70	70	70	70	70	70
		(A + B) ÷ 2 = 9'-0" (2743)	70	70	70	70	70	70	70	70	70	70	70	70	70	70
		(A + B) ÷ 2 = 8'-6" (2591)	70	70	70	70	70	70	70	70	70	70	70	70	70	70
		(A + B) ÷ 2 = 8'-0" (2438)	70	70	70	70	70	70	70	70	70	70	70	70	70	70
		(A + B) ÷ 2 = 7'-6" (2286)	70	70	70	70	70	70	70	70	70	70	70	70	70	70
		(A + B) ÷ 2 = 7'-0" (2134)	70	70	70	70	70	70	70	70	70	70	70	70	70	70
		(A + B) ÷ 2 = 6'-6" (1981)	70	70	70	70	70	70	70	70	70	70	70	70	70	70
		(A + B) ÷ 2 = 6'-0" (1829)	70	70	70	70	70	70	70	70	70	70	70	70	70	70
		(A + B) ÷ 2 = 5'-6" (1676)	70	70	70	70	70	70	70	70	70	70	70	70	70	70
		(A + B) ÷ 2 = 5'-0" (1524)	70	70	70	70	70	70	70	70	70	70	70	70	70	70
		(A + B) ÷ 2 = 4'-6" (1372)	70	70	70	70	70	70	70	70	70	70	70	70	70	70
		(A + B) ÷ 2 = 4'-0" (1219)	70	70	70	70	70	70	70	70	70	70	70	70	70	70
		(A + B) ÷ 2 = 3'-6" (1067)	70	70	70	70	70	70	70	70	70	70	70	70	70	70
		(A + B) ÷ 2 = 3'-0" (914)	70	70	70	70	70	70	70	70	70	70	70	70	70	70
		(A + B) ÷ 2 = 2'-6" (762)	70	70	70	70	70	70	70	70	70	70	70	70	70	70
		(A + B) ÷ 2 = 2'-0" (610)	70	70	70	70	70	70	70	70	70	70	70	70	70	70
		(A + B) ÷ 2 = 1'-6" (457)	70	70	70	70	70	70	70	70	70	70	70	70	70	70
		C = (length of join)	2'-0" (610)	2'-6" (762)	3'-0" (914)	3'-6" (1067)	4'-0" (1219)	4'-6" (1372)	5'-0" (1524)	5'-6" (1676)	6'-0" (1829)	6'-6" (1981)	7'-0" (2134)	7'-6" (2286)	8'-0" (2438)	

continued on next page

- Numerical values in charts represent structural pressure only.
- Structural performance of any combination is only as high as the lowest structural performance of any individual unit or joining material in the combination.
- Easy Connect and other fiberglass joins are certified up to PG70 when installed according to Andersen installation instructions.
- Andersen® products must be installed and anchored properly according to joining and installation instructions to meet rated structural performance. Refer to product joining and installation instructions at andersenwindows.com.
- Dimensions in parentheses are in millimeters.
- Contact your Andersen supplier for joining windows to patio doors and for specific performance and product recommendations.
- Hinged inswing patio doors with a 6 9/16" (167) or greater exterior extension jamb depth require 7 3/4" (197) fiberglass joining material.
- Two-panel doors shown. Three- and four-panel doors similar with different overall A and B widths.

1-Way Easy Connect Fiberglass Joining continued from previous page

52	42	33	27	22					
52	42	33	27	22					
52	42	33	27	22					
52	42	33	27	22					
52	42	33	27	22					
52	42	33	27	23					
52	42	34	27	23					
52	42	34	28	23	20				
53	42	35	29	24	20				
53	43	35	29	25	21				
55	44	37	31	26	22				
56	46	38	32	27	23	20			
59	48	40	34	29	25	21			
62	51	43	36	31	26	23	20		
66	55	46	39	33	28	25	21		
70	59	50	42	36	31	27	24		
70	65	55	47	40	35	30	26		
70	70	62	53	45	39	34	30		
70	70	70	61	52	45	39	34		
70	70	70	70	62	54	47	41		
70	70	70	70	70	67	58	51		
70	70	70	70	70	70	70	68		
8'-6" (2591)	9'-0" (2743)	9'-6" (2896)	10'-0" (3048)	10'-6" (3200)	11'-0" (3353)	11'-6" (3505)	12'-0" (3658)		

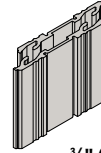
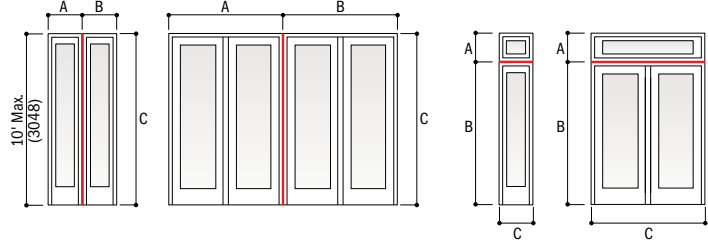

3/4" (19) x 5 3/4" (146)
Easy Connect Fiberglass Joining Material
For 4 9/16" (116) base jamb depths.

When joining hinged patio doors,
do not join hinge jamb to hinge jamb.

A structural header is required to separate
patio door transoms and transom windows
from 4-panel gliding patio doors.

1-Way Easy Connect Fiberglass Joining continued from previous page

70	64	58	52	47	39	33	28	23	20		
70	64	58	52	47	39	33	28	23	20		
70	64	58	52	47	39	33	28	23	20		
70	64	58	52	47	39	33	28	24	21		
70	64	58	52	47	40	34	29	24	21		
70	64	58	52	48	40	34	29	25	22		
70	64	58	53	48	41	35	30	25	22		
70	65	58	53	49	42	36	31	26	23	20	
70	65	59	54	50	43	37	32	27	24	21	
70	66	60	56	51	45	39	33	29	25	22	20
70	68	62	57	53	47	40	35	30	26	23	21
70	70	64	59	55	49	43	37	32	28	25	22
70	70	67	62	58	52	45	39	34	30	26	24
70	70	70	65	61	56	48	42	36	32	29	25
70	70	70	70	65	60	52	46	40	35	33	28
70	70	70	70	70	66	57	52	44	38	34	30
70	70	70	70	70	70	64	56	48	43	38	34
70	70	70	70	70	70	70	63	55	49	43	39
70	70	70	70	70	70	70	70	64	56	50	45
70	70	70	70	70	70	70	70	70	67	60	54
70	70	70	70	70	70	70	70	70	70	70	67
70	70	70	70	70	70	70	70	70	70	70	70
8'-6" (2591)	9'-0" (2743)	9'-6" (2896)	10'-0" (3048)	10'-6" (3200)	11'-0" (3353)	11'-6" (3505)	12'-0" (3658)	12'-6" (3658)	13'-0" (3658)	13'-6" (3658)	14'-0" (3658)

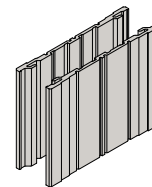
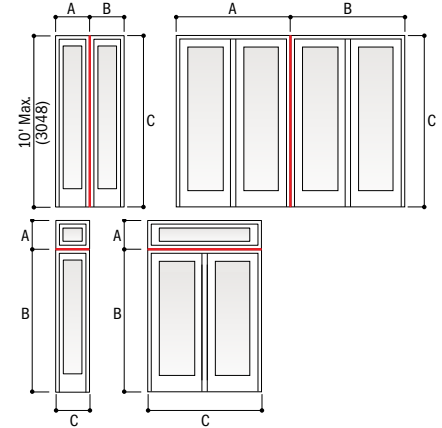

3/4" (19) x 7 3/4" (197)
Easy Connect Fiberglass Joining Material
For higher performance for 1-way and 2-way joining. Required for hinged inswing patio doors with 6 7/16" (167) or greater exterior extension jamb depths.

When joining hinged patio doors,
do not join hinge jamb to hinge jamb.

A structural header is required
to separate patio door transoms
and transom windows from 4-panel
gliding patio doors.

- Numerical values in charts represent structural pressure only.
- Structural performance of any combination is only as high as the lowest structural performance of any individual unit or joining material in the combination.
- Easy Connect and other fiberglass joins are certified up to PG70 when installed according to Andersen installation instructions.
- Andersen® products must be installed and anchored properly according to joining and installation instructions to meet rated structural performance. Refer to product joining and installation instructions at andersenwindows.com.
- Dimensions in parentheses are in millimeters.
- Contact your Andersen supplier for joining windows to patio doors and for specific performance and product recommendations.
- Hinged inswing patio doors with a 6 7/16" (167) or greater exterior extension jamb depth require 7 3/4" (197) fiberglass joining material.

*Two-panel doors shown. Three- and four-panel doors similar with different overall A and B widths.

Combination Designs,
Product Performance
& Installation

COMBINATION DESIGNS

2-Way Easy Connect Fiberglass Joining

A-Series Gliding and Hinged Patio Doors, Sidelights and Transoms

4 9/16" (116) Minimum Wall Depth	Average Adjacent Window Dimension	(A + B) ÷ 2 = 12'-0" (3658)	70	70	69	59	52	46	41	38	34	32	29	27	26
		(A + B) ÷ 2 = 11'-6" (3505)	70	70	70	62	54	48	43	39	36	33	31	29	27
		(A + B) ÷ 2 = 11'-0" (3353)	70	70	70	65	57	50	45	41	38	35	32	30	28
		(A + B) ÷ 2 = 10'-6" (3200)	70	70	70	68	59	53	47	43	39	36	34	31	29
		(A + B) ÷ 2 = 10'-0" (3048)	70	70	70	70	62	55	50	45	41	38	35	33	31
		(A + B) ÷ 2 = 9'-6" (2896)	70	70	70	70	66	58	52	48	44	40	37	35	32
		(A + B) ÷ 2 = 9'-0" (2743)	70	70	70	70	69	62	55	50	46	43	39	37	34
		(A + B) ÷ 2 = 8'-6" (2591)	70	70	70	70	70	65	59	53	49	45	42	39	36
		(A + B) ÷ 2 = 8'-0" (2438)	70	70	70	70	70	69	62	57	52	48	44	41	39
		(A + B) ÷ 2 = 7'-6" (2286)	70	70	70	70	70	70	67	60	55	51	47	44	41
		(A + B) ÷ 2 = 7'-0" (2134)	70	70	70	70	70	70	70	65	59	55	51	47	44
		(A + B) ÷ 2 = 6'-6" (1981)	70	70	70	70	70	70	70	70	64	59	55	51	48
		(A + B) ÷ 2 = 6'-0" (1829)	70	70	70	70	70	70	70	70	69	64	59	55	52
		(A + B) ÷ 2 = 5'-6" (1676)	70	70	70	70	70	70	70	70	70	70	65	60	56
		(A + B) ÷ 2 = 5'-0" (1524)	70	70	70	70	70	70	70	70	70	70	70	67	62
		(A + B) ÷ 2 = 4'-6" (1372)	70	70	70	70	70	70	70	70	70	70	70	70	69
		(A + B) ÷ 2 = 4'-0" (1219)	70	70	70	70	70	70	70	70	70	70	70	70	70
		(A + B) ÷ 2 = 3'-6" (1067)	70	70	70	70	70	70	70	70	70	70	70	70	70
		(A + B) ÷ 2 = 3'-0" (914)	70	70	70	70	70	70	70	70	70	70	70	70	70
		(A + B) ÷ 2 = 2'-6" (762)	70	70	70	70	70	70	70	70	70	70	70	70	70
		(A + B) ÷ 2 = 2'-0" (610)	70	70	70	70	70	70	70	70	70	70	70	70	70
		(A + B) ÷ 2 = 1'-6" (457)	70	70	70	70	70	70	70	70	70	70	70	70	70
		C = (length of join)	2'-0" (610)	2'-6" (762)	3'-0" (914)	3'-6" (1067)	4'-0" (1219)	4'-6" (1372)	5'-0" (1524)	5'-6" (1676)	6'-0" (1829)	6'-6" (1981)	7'-0" (2134)	7'-6" (2286)	8'-0" (2438)

continued on next page

2-Way Easy Connect Fiberglass Joining

A-Series Gliding and Hinged Patio Doors, Sidelights and Transoms

6 9/16" (167) Minimum Wall Depth	Average Adjacent Window Dimension	(A + B) ÷ 2 = 12'-0" (3658)	70	70	69	59	52	46	41	38	34	32	29	27	26
		(A + B) ÷ 2 = 11'-6" (3505)	70	70	70	62	54	48	43	39	36	35	31	29	27
		(A + B) ÷ 2 = 11'-0" (3353)	70	70	70	65	57	50	45	41	38	35	32	30	28
		(A + B) ÷ 2 = 10'-6" (3200)	70	70	70	68	59	53	47	43	39	36	34	31	29
		(A + B) ÷ 2 = 10'-0" (3048)	70	70	70	70	62	55	50	45	41	38	35	33	31
		(A + B) ÷ 2 = 9'-6" (2896)	70	70	70	70	66	58	52	48	44	40	37	35	33
		(A + B) ÷ 2 = 9'-0" (2743)	70	70	70	70	69	62	55	50	46	43	39	37	34
		(A + B) ÷ 2 = 8'-6" (2591)	70	70	70	70	70	65	59	53	49	45	42	39	37
		(A + B) ÷ 2 = 8'-0" (2438)	70	70	70	70	70	69	62	57	52	48	44	41	39
		(A + B) ÷ 2 = 7'-6" (2286)	70	70	70	70	70	70	67	60	55	51	47	44	41
		(A + B) ÷ 2 = 7'-0" (2134)	70	70	70	70	70	70	70	65	59	55	51	47	44
		(A + B) ÷ 2 = 6'-6" (1981)	70	70	70	70	70	70	70	70	64	59	56	51	48
		(A + B) ÷ 2 = 6'-0" (1829)	70	70	70	70	70	70	70	70	69	64	59	55	52
		(A + B) ÷ 2 = 5'-6" (1676)	70	70	70	70	70	70	70	70	70	70	62	60	57
		(A + B) ÷ 2 = 5'-0" (1524)	70	70	70	70	70	70	70	70	70	70	70	67	62
		(A + B) ÷ 2 = 4'-6" (1372)	70	70	70	70	70	70	70	70	70	70	70	70	69
		(A + B) ÷ 2 = 4'-0" (1219)	70	70	70	70	70	70	70	70	70	70	70	70	70
		(A + B) ÷ 2 = 3'-6" (1067)	70	70	70	70	70	70	70	70	70	70	70	70	70
		(A + B) ÷ 2 = 3'-0" (914)	70	70	70	70	70	70	70	70	70	70	70	70	70
		(A + B) ÷ 2 = 2'-6" (762)	70	70	70	70	70	70	70	70	70	70	70	70	70
		(A + B) ÷ 2 = 2'-0" (610)	70	70	70	70	70	70	70	70	70	70	70	70	70
		(A + B) ÷ 2 = 1'-6" (457)	70	70	70	70	70	70	70	70	70	70	70	70	70
		C = (length of join)	2'-0" (610)	2'-6" (762)	3'-0" (914)	3'-6" (1067)	4'-0" (1219)	4'-6" (1372)	5'-0" (1524)	5'-6" (1676)	6'-0" (1829)	6'-6" (1981)	7'-0" (2134)	7'-6" (2286)	8'-0" (2438)

continued on next page

- * Numerical values in charts represent structural pressure only.
- * Structural performance of any combination is only as high as the lowest structural performance of any individual unit or joining material in the combination.
- * Easy Connect and other fiberglass joins are certified up to PG70 when installed according to Andersen installation instructions.
- * Andersen® products must be installed and anchored properly according to joining and installation instructions to meet rated structural performance. Refer to product joining and installation instructions at andersenwindows.com.
- * Dimensions in parentheses are in millimeters.
- * Contact your Andersen supplier for joining windows to patio doors and for specific performance and product recommendations.
- * Hinged inswing patio doors with a 6 9/16" (167) or greater exterior extension jamb depth require 7 3/4" (197) fiberglass joining material.
- * Two-panel doors shown. Three- and four-panel doors similar with different overall A and B widths.

2-Way Easy Connect Fiberglass Joining continued from previous page

23	20						
24	21						
25	22	20					
26	23	21					
27	24	22	20				
29	26	23	21				
30	27	24	22	20			
32	29	26	23	21			
34	30	27	25	22	20		
36	32	29	26	24	22	20	
39	35	31	28	25	23	21	
42	38	34	30	27	25	23	21
46	41	36	33	30	27	25	23
50	44	40	36	33	30	27	25
55	49	44	40	36	33	30	27
61	54	49	44	40	36	33	30
69	61	55	50	45	41	37	34
70	54	63	57	51	47	43	39
70	70	70	66	60	55	50	46
70	70	70	70	70	66	60	55
70	70	70	70	70	70	70	69
70	70	70	70	70	70	70	70
8'-6" (2591)	9'-0" (2743)	9'-6" (2896)	10'-0" (3048)	10'-6" (3200)	11'-0" (3353)	11'-6" (3505)	12'-0" (3658)

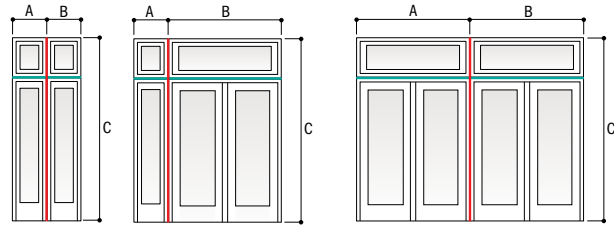

Red lines represent priority join (dimension C in table).

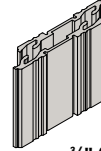

**3/4" (19) x 5 3/4" (146)
Easy Connect Fiberglass Joining Material**

For 4 9/16" (116) base jamb depths.

**When joining hinged patio doors,
do not join hinge jamb to hinge jamb.**

**A structural header is required to separate
patio door transoms and transom windows
from 4-panel gliding patio doors.**

2-Way Easy Connect Fiberglass Joining continued from previous page

24	23	22	20								
25	24	23	21	20							
26	25	24	22	21	20						
28	26	25	23	22	21	20					
29	27	26	25	23	22	21	20				
31	29	27	26	25	24	23	22				
32	31	29	27	26	25	24	23	21			
34	32	31	29	28	26	25	24	22	21		
37	34	33	31	29	28	27	26	24	22	20	
39	37	35	33	31	30	29	27	25	23	22	20
42	39	37	35	34	32	31	29	27	25	23	22
45	43	40	38	36	35	33	32	29	27	25	23
49	46	44	41	39	38	36	34	32	29	27	26
53	50	48	45	43	41	39	38	35	32	30	28
59	55	52	50	47	45	43	42	38	35	33	30
65	62	58	55	53	50	48	46	43	39	37	34
70	69	66	62	59	57	54	52	48	44	41	38
70	70	70	70	68	65	62	59	55	51	47	44
70	70	70	70	70	70	70	69	64	59	55	51
70	70	70	70	70	70	70	70	70	70	66	61
70	70	70	70	70	70	70	70	70	70	70	70
70	70	70	70	70	70	70	70	70	70	70	70
8'-6" (2591)	9'-0" (2743)	9'-6" (2896)	10'-0" (3048)	10'-6" (3200)	11'-0" (3353)	11'-6" (3505)	12'-0" (3658)	12'-6" (3658)	13'-0" (3658)	13'-6" (3658)	14'-0" (3658)

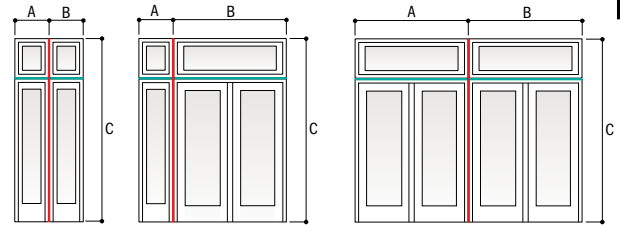

Red lines represent priority join (dimension C in table).

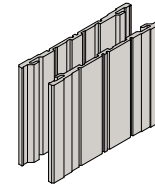

**3/4" (19) x 7 3/4" (197)
Easy Connect Fiberglass
Joining Material**

For higher performance for 1-way and 2-way joining. Required for hinged inswing patio doors with 6 9/16" (167) or greater exterior extension jamb depths.

**When joining hinged patio doors,
do not join hinge jamb to hinge jamb.**

**A structural header is required
to separate patio door transoms
and transom windows from 4-panel
gliding patio doors.**

- Numerical values in charts represent structural pressure only.
- Structural performance of any combination is only as high as the lowest structural performance of any individual unit or joining material in the combination.
- Easy Connect and other fiberglass joins are certified up to PG70 when installed according to Andersen installation instructions.
- Andersen® products must be installed and anchored properly according to joining and installation instructions to meet rated structural performance. Refer to product joining and installation instructions at andersenwindows.com.
- Dimensions in parentheses are in millimeters.
- Contact your Andersen supplier for joining windows to patio doors and for specific performance and product recommendations.
- Hinged inswing patio doors with a 6 9/16" (167) or greater exterior extension jamb depth require 7 3/4" (197) fiberglass joining material.

*Two-panel doors shown. Three- and four-panel doors similar with different overall A and B widths.

PRODUCT PERFORMANCE

Andersen® Window and Patio Door Altitude Limits – Dual-Pane Glass

The chart below gives the altitude limit in feet for most A-Series products in this guide. If the installation of a given product is at an altitude greater than that shown in this chart, a capillary breather tube must be ordered. Be aware that the use of a capillary breather tube eliminates argon gas blend fill and will result in a slightly lower thermal performance (approximately 0.02 increase in window U-Factor). For NFRC certified total unit performance on units with capillary breather tubes for higher altitude applications, please visit andersenwindows.com/nfrc.

The use of dual-pane insulating glass at altitudes higher than its rating will result in severe glass distortion, increased glass breakage potential and a risk of seal failure. Smaller windows are most affected by altitude changes. An increase in altitude results in a decrease in atmospheric pressure. A sealed insulating glass unit attempts to combat this change by increasing its volume to reduce its pressure. One way to increase its volume is by glass deflection. A smaller window is stiffer and does not deflect as much as a larger window; therefore, it cannot relieve the pressure as readily. Thus the load applied to the glass is greater, resulting in a greater risk for breakage. Another way the window tries to increase its volume is by increasing the edge area; i.e., the seal area. The increased pressure applied to the edge seal load for smaller windows is therefore greater, increasing the chance for seal failure.

Product	3,000	4,000				5,000		6,000		7,000		8,000		9,000	10,000											
A-Series Casement Windows	ACW1820 ACW1824 ACW1828 ACW1830 ACW1834	ACW1838 ACW1840 ACW1844 ACW1848 ACW1850	ACW1854 ACW1858 ACW1860 ACW1862 ACW1866	ACW2028 ACW2030 ACW2034 ACW2036 ACW2040	ACW2038 ACW2040 ACW2044 ACW2048 ACW2050 ACW2054 ACW2058 ACW2060	ACW2424 ACW2428 ACW2430 ACW2434 ACW2438 ACW2440 ACW2444 ACW2448 ACW2452	ACW2634 ACW2638 ACW2640 ACW2644 ACW2648 ACW2652 ACW2656 ACW2660 ACW2664	ACW2648 ACW2650 ACW2654 ACW2658 ACW2662 ACW2666 ACW2670 ACW2674 ACW2678 ACW2682 ACW2686 ACW2690	ACW2854 ACW2858 ACW2860 ACW2864 ACW2868 ACW2872 ACW2876 ACW2880 ACW2884 ACW2888 ACW2892 ACW2896 ACW2900	ACW2850 ACW21054 ACW21058 ACW21062 ACW21066 ACW21070 ACW21074 ACW21078 ACW21082 ACW21086 ACW21090	ACW3040 ACW3044 ACW3048 ACW3050 ACW3054 ACW3058 ACW3060		AAW5430													
A-Series Awning Windows		AAW1814 AAW2014 AAW2414 AAW2614 AAW2814 AAW21014 AAW3014 AAW3214 AAW3414 AAW3814 AAW4014 AAW4414 AAW4814 AAW5014 AAW5414 AAW5814	AAW6014 AAW618 AAW618 AAW618 AAW618 AAW618 AAW618 AAW618 AAW618 AAW618 AAW618 AAW618 AAW618 AAW618 AAW618 AAW618 AAW618	AAW5818 AAW6018 AAW618 AAW618 AAW618 AAW618 AAW618 AAW618 AAW618 AAW618 AAW618 AAW618 AAW618 AAW618 AAW618 AAW618 AAW618	AAW40110 AAW44110 AAW48110 AAW50110 AAW54110 AAW58110 AAW60110 AAW62110 AAW64110 AAW66110 AAW68110 AAW70110 AAW72110 AAW74110 AAW76110 AAW78110 AAW80110	AAW3420 AAW3820 AAW4020 AAW4420 AAW4820 AAW5020 AAW5420 AAW5820 AAW6020 AAW6220 AAW6420 AAW6620 AAW6820 AAW7020 AAW7220 AAW7420 AAW7620 AAW7820 AAW8020	AAW2624 AAW2824 AAW3028 AAW3224 AAW3424 AAW3624 AAW3824 AAW4028 AAW4224 AAW4424 AAW4624 AAW4824 AAW5024 AAW5224 AAW5424 AAW5624 AAW5824 AAW6024 AAW6224 AAW6424 AAW6624 AAW6824 AAW7024 AAW7224 AAW7424 AAW7624 AAW7824 AAW8024	AAW2828 AAW21028 AAW3028 AAW3228 AAW3428 AAW3628 AAW3828 AAW4028 AAW4228 AAW4428 AAW4628 AAW4828 AAW5028 AAW5228 AAW5428 AAW5628 AAW5828 AAW6028 AAW6228 AAW6428 AAW6628 AAW6828 AAW7028 AAW7228 AAW7428 AAW7628 AAW7828 AAW8028	AAW4828 AAW5028 AAW5428 AAW5828 AAW6028 AAW6228 AAW6428 AAW6628 AAW6828 AAW7028 AAW7228 AAW7428 AAW7628 AAW7828 AAW8028	AAW3030 AAW3230 AAW3430 AAW3830 AAW4030 AAW4430 AAW4830 AAW5030 AAW5830 AAW6030																
A-Series Double-Hung Windows	ADH1830 ADH1834 ADH1838 ADH1840 ADH1844 ADH1848 ADH1850 ADH1854 ADH1858 ADH1860 ADH1864 ADH1868 ADH1874	ADH1880 ADH2030 ADH2034 ADH2038 ADH2040 ADH2044 ADH2048 ADH2050 ADH2054 ADH2058 ADH2060 ADH2064 ADH2430	ADH2434 ADH2630 ADH2634 ADH2638 ADH2640 ADH2644 ADH2648 ADH2650 ADH2654 ADH2658 ADH2660 ADH2664 ADH2668 ADH2670 ADH2674	ADH3038 ADH3230 ADH3234 ADH3238 ADH3430 ADH3434 ADH3438 ADH3830 ADH3834 ADH4030 ADH4034	ADH2068 ADH2074 ADH2080 ADH2440 ADH2444 ADH2448 ADH2450 ADH2454 ADH2458 ADH2460 ADH2464 ADH2468 ADH2474 ADH2640 ADH2644 ADH2648 ADH2652 ADH2656 ADH2660 ADH2664 ADH2668 ADH2672	ADH3040 ADH3044 ADH2840 ADH2844 ADH2848 ADH3044 ADH3048 ADH3448 ADH3444 ADH3448 ADH3844 ADH3848 ADH4044 ADH4048	ADH2648 ADH2848 ADH2650 ADH2654 ADH2658 ADH2662 ADH2666 ADH2670 ADH2674	ADH2850 ADH2854 ADH2858 ADH2860 ADH2864 ADH2868 ADH2874 ADH2880 ADH21050 ADH21054 ADH21058 ADH21060 ADH21064	ADH21068 ADH21074 ADH21080 ADH3050 ADH3054 ADH3058 ADH3250 ADH3254 ADH3450 ADH3454 ADH3500 ADH3504	ADH3058 ADH3268 ADH3060 ADH3064 ADH3068 ADH3074 ADH3080 ADH3258 ADH3262 ADH3266 ADH3270 ADH3274 ADH3278 ADH3282 ADH3286 ADH3290 ADH3294 ADH3298 ADH3302 ADH3306 ADH3310 ADH3314 ADH3318 ADH3322 ADH3326 ADH3330 ADH3334 ADH3338 ADH3342 ADH3346 ADH3350 ADH3354 ADH3358 ADH3362 ADH3366 ADH3370 ADH3374 ADH3378 ADH3382 ADH3386 ADH3390 ADH3394 ADH3398 ADH3402 ADH3406 ADH3410 ADH3414 ADH3418 ADH3422 ADH3426 ADH3430 ADH3434 ADH3438 ADH3442 ADH3446 ADH3450 ADH3454 ADH3458 ADH3462 ADH3466 ADH3470 ADH3474 ADH3478 ADH3482 ADH3486 ADH3490 ADH3494 ADH3498 ADH3502 ADH3506 ADH3510 ADH3514 ADH3518 ADH3522 ADH3526 ADH3530 ADH3534 ADH3538 ADH3542 ADH3546 ADH3550 ADH3554 ADH3558 ADH3562 ADH3566 ADH3570 ADH3574 ADH3578 ADH3582 ADH3586 ADH3590 ADH3594 ADH3598 ADH3602 ADH3606 ADH3610 ADH3614 ADH3618 ADH3622 ADH3626 ADH3630 ADH3634 ADH3638 ADH3642 ADH3646 ADH3650 ADH3654 ADH3658 ADH3662 ADH3666 ADH3670 ADH3674 ADH3678 ADH3682 ADH3686 ADH3690 ADH3694 ADH3698 ADH3702 ADH3706 ADH3710 ADH3714 ADH3718 ADH3722 ADH3726 ADH3730 ADH3734 ADH3738 ADH3742 ADH3746 ADH3750 ADH3754 ADH3758 ADH3762 ADH3766 ADH3770 ADH3774 ADH3778 ADH3782 ADH3786 ADH3790 ADH3794 ADH3798 ADH3802 ADH3806 ADH3810 ADH3814 ADH3818 ADH3822 ADH3826 ADH3830 ADH3834 ADH3838 ADH3842 ADH3846 ADH3850 ADH3854 ADH3858 ADH3862 ADH3866 ADH3870 ADH3874 ADH3878 ADH3882 ADH3886 ADH3890 ADH3894 ADH3898 ADH3902 ADH3906 ADH3910 ADH3914 ADH3918 ADH3922 ADH3926 ADH3930 ADH3934 ADH3938 ADH3942 ADH3946 ADH3950 ADH3954 ADH3958 ADH3962 ADH3966 ADH3970 ADH3974 ADH3978 ADH3982 ADH3986 ADH3990 ADH3994 ADH3998 ADH4002 ADH4006 ADH4010 ADH4014 ADH4018 ADH4022 ADH4026 ADH4030 ADH4034 ADH4038 ADH4042 ADH4046 ADH4050 ADH4054	ADH3464 ADH3468 ADH3874 ADH3878 ADH3880 ADH3884 ADH3888 ADH4064 ADH4068	ADH3868 ADH3872 ADH3880 ADH4068 ADH4072														
A-Series Picture Windows	APW1420 APW1424 APW1428 APW1430 APW1434 APW1438 APW1440 APW1448 APW1450 APW1454	APW1458 APW1460 APW1464 APW1468 APW1474 APW1480 APW1484 APW1488 APW1492 APW1496 APW1500 APW1504 APW1508 APW1512 APW1516 APW1520 APW1524 APW1528 APW1532 APW1536 APW1540 APW1544 APW1548 APW1552 APW1556 APW1560 APW1564 APW1568 APW1572 APW1576 APW1580 APW1584 APW1588 APW1592 APW1596 APW1600 APW1604 APW1608 APW1612 APW1616 APW1620 APW1624 APW1628 APW1632 APW1636 APW1640 APW1644 APW1648 APW1652 APW1656 APW1660 APW1664 APW1668 APW1672 APW1676 APW1680 APW1684 APW1688 APW1692 APW1696 APW1700 APW1704 APW1708 APW1712 APW1716 APW1720 APW1724 APW1728 APW1732 APW1736 APW1740 APW1744 APW1748 APW1752 APW1756 APW1760 APW1764 APW1768 APW1772 APW1776 APW1780 APW1784 APW1788 APW1792 APW1796 APW1800 APW1804 APW1808 APW1812 APW1816 APW1820 APW1824 APW1828 APW1832 APW1836 APW1840 APW1844 APW1848 APW1852 APW1856 APW1860 APW1864 APW1868 APW1872 APW1876 APW1880 APW1884 APW1888 APW1892 APW1896 APW1900 APW1904 APW1908 APW1912 APW1916 APW1920 APW1924 APW1928 APW1932 APW1936 APW1940 APW1944 APW1948 APW1952 APW1956 APW1960 APW1964 APW1968 APW1972 APW1976 APW1980 APW1984 APW1988 APW1992 APW1996 APW2000 APW2004 APW2008 APW2012 APW2016 APW2020 APW2024 APW2028 APW2032 APW2036 APW2040 APW2044 APW2048 APW2052 APW2056 APW2060 APW2064 APW2068 APW2072 APW2076 APW2080 APW2084 APW2088 APW2092 APW2096 APW2100 APW2104 APW2108 APW2112 APW2116 APW2120 APW2124 APW2128 APW2132 APW2136 APW2140 APW2144 APW2148 APW2152 APW2156 APW2160 APW2164 APW2168 APW2172 APW2176 APW2180 APW2184 APW2188 APW2192 APW2196 APW2200 APW2204 APW2208 APW2212 APW2216 APW2220 APW2224 APW2228 APW2232 APW2236 APW2240 APW2244 APW2248 APW2252 APW2256 APW2260 APW2264 APW2268 APW2272 APW2276 APW2280 APW2284 APW2288 APW2292 APW2296 APW2300 APW2304 APW2308 APW2312 APW2316 APW2320 APW2324 APW2328 APW2332 APW2336 APW2340 APW2344 APW2348 APW2352 APW2356 APW2360 APW2364 APW2368 APW2372 APW2376 APW2380 APW2384 APW2388 APW2392 APW2396 APW2400 APW2404 APW2408 APW2412 APW2416 APW2420 APW2424 APW2428 APW2432 APW2436 APW2440 APW2444 APW2448 APW2452 APW2456 APW2460 APW2464 APW2468 APW2472 APW2476 APW2480 APW2484 APW2488 APW2492 APW2496 APW2500 APW2504 APW2508 APW2512 APW2516 APW2520 APW2524 APW2528 APW2532 APW2536 APW2540 APW2544 APW2548 APW2552 APW2556 APW2560 APW2564 APW2568 APW2572 APW2576 APW2580 APW2584 APW2588 APW2592 APW2596 APW2600 APW2604 APW2608 APW2612 APW2616 APW2620 APW2624 APW2628 APW2632 APW2636 APW2640 APW2644 APW2648 APW2652 APW2656 APW2660 APW2664 APW2668 APW2672 APW2676 APW2680 APW2684 APW2688 APW2692 APW2696 APW2700 APW2704 APW2708 APW2712 APW2716 APW2720 APW2724 APW2728 APW2732 APW2736 APW2740 APW2744 APW2748 APW2752 APW2756 APW2760 APW2764 APW2768 APW2772 APW2776 APW2780 APW2784 APW2788 APW2792 APW2796 APW2800 APW2804 APW2808 APW2812 APW2816 APW2820 APW2824 APW2828 APW2832 APW2836 APW2840 APW2844 APW2848 APW2852 APW2856 APW2860 APW2864 APW2868 APW2872 APW2876 APW2880 APW2884 APW2888 APW2892 APW2896 APW2900 APW2904 APW2908 APW2912 APW2916 APW2920 APW2924 APW2928 APW2932 APW2936 APW2940 APW2944 APW2948 APW2952 APW2956 APW2960 APW2964 APW2968 APW2972 APW2976 APW2980 APW2984 APW2988 APW2992 APW2996 APW3000 APW3004 APW3008 APW3012 APW3016 APW3020 APW3024 APW3028 APW3032 APW3036 APW3040 APW3044 APW3048 APW3052 APW3056 APW3060 APW3064 APW3068 APW3072 APW3076 APW3080 APW3084 APW3088 APW3092 APW3096 APW3100 APW3104 APW3108 APW3112 APW3116 APW3120 APW3124 APW3128 APW3132 APW3136 APW3140 APW3144 APW3148 APW3152 APW3156 APW3160 APW3164 APW3168 APW3172 APW3176 APW3180 APW3184 APW3188 APW3192 APW3196 APW3200 APW3204 APW3208 APW3212 APW3216 APW3220 APW3224 APW3228 APW3232 APW3236 APW3240 APW3244 APW3248 APW3252 APW3256 APW3260 APW3264 APW3268 APW3272 APW3276 APW3280 APW3284 APW3288 APW3292 APW3296 APW3300 APW3304 APW3308 APW3312 APW3316 APW3320 APW3324 APW3328 APW3332 APW3336 APW3340 APW3344 APW3348 APW3352 APW3356 APW3360 APW3364 APW3368 APW3372 APW3376 APW3380 APW3384 APW3388 APW3392 APW3396 APW3400 APW3404 APW3408 APW3412 APW3416 APW3420 APW3424 APW3428 APW3432 APW3436 APW3440 APW3444 APW3448 APW3452 APW3456 APW3460 APW3464 APW3468 APW3472 APW3476 APW3480 APW3484 APW3488 APW3492 APW3496 APW3500 APW3504 APW3508 APW3512 APW3516 APW3520 APW3524 APW3528 APW3532 APW3536 APW3540 APW3544 APW3548 APW3552 APW3556 APW3560 APW3564 APW3568 APW3572 APW3576 APW3580 APW3584 APW3588 APW3592 APW3596 APW3600 APW3604 APW3608 APW3612 APW3616 APW3620 APW3624 APW3628 APW3632 APW3636 APW3640 APW3644 APW3648 APW3652 APW3656 APW3660 APW3664 APW3668 APW3672 APW3676 APW3680 APW3684 APW3688 APW3692 APW3696 APW3700 APW3704 APW3708 APW3712 APW3716 APW3720 APW3724 APW3728 APW3732 APW3736 APW3740 APW3744 APW3748 APW3752 APW3756 APW3760 APW3764 APW3768 APW3772 APW3776 APW3780 APW3784 APW3788 APW3792 APW3796 APW3800 APW3804 APW3808 APW3812 APW3816 APW3820 APW3824 APW3828 APW3832 APW3836 APW3840 APW3844 APW3848 APW3852 APW3856 APW3860 APW3864 APW3868 APW3872 APW3876 APW3880 APW3884 APW3888 APW3892 APW3896 APW3900 APW3904 APW3908 APW3912 APW3916 APW3920 APW3924 APW3928 APW3932 APW3936 APW3940 APW3944 APW3948 APW3952 APW3956 APW3960 APW3964 APW3968 APW3972 APW3976 APW3980 APW3984 APW3988 APW3992 APW3996 APW4000 APW4004 APW4008 APW4012 APW4016 APW4020 APW4024 APW4028 APW4032 APW4036 APW4040 APW4044 APW4048 APW4052 APW4056 APW4060 APW4064 APW4068 APW4072 APW4076 APW4080 APW4084 APW4088 APW4092 APW4096 APW4100 APW4104 APW4108 APW4112 APW4116 APW4120 APW4124 APW4128 APW4132 APW4136 APW4140 APW4144 APW4148 APW4152 APW4156 APW4160 APW4164 APW4168 APW4172 APW4176 APW4180 APW4184 APW4188 APW4192 APW4196 APW4200 APW4204 APW4208 APW4212 APW4216 APW4220 APW4224 APW4228 APW4232 APW4236 APW4240 APW4244 APW4248 APW4252 APW4256 APW4260 APW4264 APW4268 APW4272 APW4276 APW4280 APW4284 APW4288 APW4292 APW4296 APW4300 APW4304 APW4308 APW4312 APW4316 APW4320 APW4324 APW4328 APW4332 APW4336 APW4340 APW4344 APW4348 APW4352 APW4356 APW4360 APW4364 APW4368 APW4372 APW4376 APW4380 APW4384 APW4388 APW4392 APW4396 APW4400 APW4404 APW4408 APW4412 APW4416 APW4420 APW4424 APW4428 APW4432 APW4436 APW4440 APW4444 APW4448 APW4452 APW4456 APW4460 APW4464 APW4468 APW4472 APW4476 APW4480 APW4484 APW4488 APW4492 APW4496 APW4500 APW4504 APW4508 APW4512 APW4516 APW4520 APW4524 APW4528 APW4532 APW4536 APW4540 APW4544 APW4548 APW4552 APW4556 APW4560 APW4564 APW4568 APW4572 APW4576 APW4580 APW4584 APW4588 APW4592 APW4596 APW4600 APW4604 APW4608 APW4612 APW4616 APW4620 APW4624 APW4628 APW4632 APW4636 APW4640 APW4644 APW4648 APW4652 APW4656 APW4660 APW4664 APW4668 APW4672 APW4676 APW4680 APW4684 APW4688 APW4692 APW4696 APW4700 APW4704 APW4708 APW4712 APW4716 APW4720 APW																								

Andersen® Window and Patio Door Altitude Limits – Dual-Pane Glass (continued)

Product	3,000	4,000			5,000		6,000		7,000		8,000		9,000	10,000							
A-Series Fixed Transom Windows	ATF8010 ATF8014	ATF1410 ATF1810 ATF2010 ATF2410 ATF2610 ATF2810 ATF210210 ATF3010 ATF3210 ATF3410 ATF3810 ATF4010 ATF4410 ATF4810 ATF5010 ATF5410 ATF5810 ATF6010 ATF6410 ATF6810 ATF7010 ATF7410 ATF7810 ATF1414 ATF1416 ATF1418 ATF1420 ATF1422 ATF1424 ATF1426	ATF1428 ATF1430 ATF1434 ATF1814 ATF2014 ATF2414 ATF2614 ATF2814 ATF21014 ATF3014 ATF3214 ATF3414 ATF3814 ATF4014 ATF4414 ATF4814 ATF5014 ATF5414 ATF5814 ATF6014 ATF6414 ATF6814 ATF7014 ATF7414 ATF7814 ATF1414 ATF1416 ATF1418 ATF1420 ATF1422 ATF1424 ATF1426	ATF21016 ATF3016 ATF3216 ATF3416 ATF3816 ATF4016 ATF4416 ATF4816 ATF5016 ATF5416 ATF5816 ATF6016 ATF6416 ATF6816 ATF7016 ATF7416 ATF7816 ATF1816 ATF2016 ATF2216 ATF2416 ATF2616 ATF2816	ATF2818 ATF3018 ATF3018 ATF3218 ATF3418 ATF3818 ATF4018 ATF4418 ATF4818 ATF5018 ATF5418 ATF5818 ATF6018 ATF6418 ATF6818 ATF7018 ATF7418 ATF7818 ATF1818 ATF2018 ATF2218 ATF2418 ATF2618	ATF34110 ATF38110 ATF40110 ATF44110 ATF48110 ATF50110 ATF54110 ATF58110 ATF60110 ATF64110 ATF68110 ATF70110 ATF74110 ATF78110 ATF2022 ATF2024 ATF2026 ATF2028 ATF2030 ATF2034 ATF2040 ATF2042 ATF2044 ATF2046 ATF2048 ATF2050 ATF2052 ATF2054 ATF2056 ATF2058 ATF2060 ATF2062 ATF2064 ATF2066 ATF2068 ATF2070 ATF2072 ATF2074 ATF2076 ATF2078 ATF2080 ATF2082 ATF2084 ATF2086 ATF2088 ATF2090 ATF2092 ATF2094 ATF2096 ATF2098 ATF2100 ATF2102 ATF2104 ATF2106 ATF2108 ATF2110 ATF2112 ATF2114 ATF2116 ATF2118 ATF2120 ATF2122 ATF2124 ATF2126 ATF2128 ATF2130 ATF2132 ATF2134 ATF2136 ATF2138 ATF2140 ATF2142 ATF2144 ATF2146 ATF2148 ATF2150 ATF2152 ATF2154 ATF2156 ATF2158 ATF2160 ATF2162 ATF2164 ATF2166 ATF2168 ATF2170 ATF2172 ATF2174 ATF2176 ATF2178 ATF2180 ATF2182 ATF2184 ATF2186 ATF2188 ATF2190 ATF2192 ATF2194 ATF2196 ATF2198 ATF2200 ATF2202 ATF2204 ATF2206 ATF2208 ATF2210 ATF2212 ATF2214 ATF2216 ATF2218 ATF2220 ATF2222 ATF2224 ATF2226 ATF2228 ATF2230 ATF2232 ATF2234 ATF2236 ATF2238 ATF2240 ATF2242 ATF2244 ATF2246 ATF2248 ATF2250 ATF2252 ATF2254 ATF2256 ATF2258 ATF2260 ATF2262 ATF2264 ATF2266 ATF2268 ATF2270 ATF2272 ATF2274 ATF2276 ATF2278 ATF2280 ATF2282 ATF2284 ATF2286 ATF2288 ATF2290 ATF2292 ATF2294 ATF2296 ATF2298 ATF2300 ATF2302 ATF2304 ATF2306 ATF2308 ATF2310 ATF2312 ATF2314 ATF2316 ATF2318 ATF2320 ATF2322 ATF2324 ATF2326 ATF2328 ATF2330 ATF2332 ATF2334 ATF2336 ATF2338 ATF2340 ATF2342 ATF2344 ATF2346 ATF2348 ATF2350 ATF2352 ATF2354 ATF2356 ATF2358 ATF2360 ATF2362 ATF2364 ATF2366 ATF2368 ATF2370 ATF2372 ATF2374 ATF2376 ATF2378 ATF2380 ATF2382 ATF2384 ATF2386 ATF2388 ATF2390 ATF2392 ATF2394 ATF2396 ATF2398 ATF2400 ATF2402 ATF2404 ATF2406 ATF2408 ATF2410 ATF2412 ATF2414 ATF2416 ATF2418 ATF2420 ATF2422 ATF2424 ATF2426 ATF2428 ATF2430 ATF2432 ATF2434 ATF2436 ATF2438 ATF2440 ATF2442 ATF2444 ATF2446 ATF2448 ATF2450 ATF2452 ATF2454 ATF2456 ATF2458 ATF2460 ATF2462 ATF2464 ATF2466 ATF2468 ATF2470 ATF2472 ATF2474 ATF2476 ATF2478 ATF2480 ATF2482 ATF2484 ATF2486 ATF2488 ATF2490 ATF2492 ATF2494 ATF2496 ATF2498 ATF2500 ATF2502 ATF2504 ATF2506 ATF2508 ATF2510 ATF2512 ATF2514 ATF2516 ATF2518 ATF2520 ATF2522 ATF2524 ATF2526 ATF2528 ATF2530 ATF2532 ATF2534 ATF2536 ATF2538 ATF2540 ATF2542 ATF2544 ATF2546 ATF2548 ATF2550 ATF2552 ATF2554 ATF2556 ATF2558 ATF2560 ATF2562 ATF2564 ATF2566 ATF2568 ATF2570 ATF2572 ATF2574 ATF2576 ATF2578 ATF2580 ATF2582 ATF2584 ATF2586 ATF2588 ATF2590 ATF2592 ATF2594 ATF2596 ATF2598 ATF2600 ATF2602 ATF2604 ATF2606 ATF2608 ATF2610 ATF2612 ATF2614 ATF2616 ATF2618 ATF2620 ATF2622 ATF2624 ATF2626 ATF2628 ATF2630 ATF2632 ATF2634 ATF2636 ATF2638 ATF2640 ATF2642 ATF2644 ATF2646 ATF2648 ATF2650 ATF2652 ATF2654 ATF2656 ATF2658 ATF2660 ATF2662 ATF2664 ATF2666 ATF2668 ATF2670 ATF2672 ATF2674 ATF2676 ATF2678 ATF2680 ATF2682 ATF2684 ATF2686 ATF2688 ATF2690 ATF2692 ATF2694 ATF2696 ATF2698 ATF2700 ATF2702 ATF2704 ATF2706 ATF2708 ATF2710 ATF2712 ATF2714 ATF2716 ATF2718 ATF2720 ATF2722 ATF2724 ATF2726 ATF2728 ATF2730 ATF2732 ATF2734 ATF2736 ATF2738 ATF2740 ATF2742 ATF2744 ATF2746 ATF2748 ATF2750 ATF2752 ATF2754 ATF2756 ATF2758 ATF2760 ATF2762 ATF2764 ATF2766 ATF2768 ATF2770 ATF2772 ATF2774 ATF2776 ATF2778 ATF2780 ATF2782 ATF2784 ATF2786 ATF2788 ATF2790 ATF2792 ATF2794 ATF2796 ATF2798 ATF2800 ATF2802 ATF2804 ATF2806 ATF2808 ATF2810 ATF2812 ATF2814 ATF2816 ATF2818 ATF2820 ATF2822 ATF2824 ATF2826 ATF2828 ATF2830 ATF2832 ATF2834 ATF2836 ATF2838 ATF2840 ATF2842 ATF2844 ATF2846 ATF2848 ATF2850 ATF2852 ATF2854 ATF2856 ATF2858 ATF2860 ATF2862 ATF2864 ATF2866 ATF2868 ATF2870 ATF2872 ATF2874 ATF2876 ATF2878 ATF2880 ATF2882 ATF2884 ATF2886 ATF2888 ATF2890 ATF2892 ATF2894 ATF2896 ATF2898 ATF2900 ATF2902 ATF2904 ATF2906 ATF2908 ATF2910 ATF2912 ATF2914 ATF2916 ATF2918 ATF2920 ATF2922 ATF2924 ATF2926 ATF2928 ATF2930 ATF2932 ATF2934 ATF2936 ATF2938 ATF2940 ATF2942 ATF2944 ATF2946 ATF2948 ATF2950 ATF2952 ATF2954 ATF2956 ATF2958 ATF2960 ATF2962 ATF2964 ATF2966 ATF2968 ATF2970 ATF2972 ATF2974 ATF2976 ATF2978 ATF2980 ATF2982 ATF2984 ATF2986 ATF2988 ATF2990 ATF2992 ATF2994 ATF2996 ATF2998 ATF3000 ATF3002 ATF3004 ATF3006 ATF3008 ATF3010 ATF3012 ATF3014 ATF3016 ATF3018 ATF3020 ATF3022 ATF3024 ATF3026 ATF3028 ATF3030 ATF3032 ATF3034	ATF5830 ATF6030 ATF6430 ATF6830 ATF7030 ATF7430 ATF8030 ATF3234 ATF3434 ATF3834 ATF4034 ATF4434 ATF4834 ATF5034 ATF5434 ATF5834 ATF6034	ATF6434 ATF6834 ATF7034 ATF7434 ATF7834 ATF8034													
	A-Series Venting Transom Windows	ATV1814 ATV2014 ATV2214 ATV2414 ATV2614 ATV2814 ATV21014 ATV3014 ATV3214 ATV3414 ATV3814 ATV4014 ATV4414 ATV4814 ATV5014 ATV5414 ATV5814 ATV6014 ATV1816 ATV2016 ATV2216 ATV2416 ATV2616	ATV2816 ATV21016 ATV3016 ATV3216 ATV3416 ATV3816 ATV4016 ATV4416 ATV4816 ATV5016 ATV5416 ATV5816 ATV6016 ATV1818 ATV2018 ATV2218 ATV2418 ATV2618 ATV2818 ATV3018 ATV3218 ATV3418 ATV3818 ATV4018 ATV4418 ATV4818 ATV5018 ATV5418 ATV5818 ATV6018 ATV1820 ATV2020 ATV2220 ATV2420 ATV2620 ATV2820 ATV3020 ATV3220 ATV3420 ATV3820 ATV4020 ATV1822 ATV2022 ATV2222 ATV2422 ATV2622 ATV2822 ATV3022 ATV3222 ATV3422 ATV3822 ATV4022	ATV2618 ATV2818 ATV21018 ATV3018 ATV3218 ATV3418 ATV3818 ATV4018 ATV4418 ATV4818 ATV5018 ATV5418 ATV5818 ATV6018 ATV1822 ATV2022 ATV2222 ATV2422 ATV2622 ATV2822 ATV3022 ATV3222 ATV3422 ATV3822 ATV4022	ATV38110 ATV40110 ATV44110 ATV48110 ATV50110 ATV54110 ATV58110 ATV60110 ATV2422 ATV2622 ATV2822 ATV3022 ATV3222 ATV3422 ATV3822 ATV4022	ATV3820 ATV4422 ATV4824 ATV5024 ATV5424 ATV5824 ATV6024 ATV2424 ATV2624 ATV2824 ATV3024 ATV3224 ATV3424	ATV21026 ATV3026 ATV3226 ATV3426 ATV3826 ATV4026 ATV4426 ATV4826 ATV5026 ATV5426 ATV5826 ATV6026	ATV4826 ATV3828 ATV5028													
		A-Series Patio Door Transoms Sash-Set	FWTD-1-81110 FWTD-1-9610 FWTD-1-81114 FWTD-1-9614	FWTD-1-2110 FWTD-1-2710 FWTD-1-2910 FWTD-1-3110 FWTD-1-3310 FWTD-2-4010 FWTD-2-5010 FWTD-2-5410 FWTD-2-6010 FWTD-2-6410 FWTD-3-7110 FWTD-3-81110 FWTD-3-9610 FWTD-1-4010 FWTD-1-5010 FWTD-1-5410 FWTD-1-6010	FWTD-1-6410 FWTD-1-7010 FWTD-1-71110 FWTD-1-8010 FWTD-1-2114 FWTD-1-2714 FWTD-1-2914 FWTD-1-3114 FWTD-1-3314 FWTD-2-6010 FWTD-2-4014 FWTD-2-5014 FWTD-2-5414 FWTD-2-6014 FWTD-2-6414 FWTD-3-7114 FWTD-3-81114 FWTD-3-9614	FWTD-1-4014 FWTD-1-5014 FWTD-1-5414 FWTD-1-6014 FWTD-1-6414 FWTD-1-7014 FWTD-1-71114 FWTD-1-8014 FWTD-1-8118 FWTD-1-2118 FWTD-1-2718 FWTD-1-2918 FWTD-1-3118 FWTD-1-3318 FWTD-2-4018 FWTD-2-5018 FWTD-2-5418 FWTD-2-6018	FWTD-2-6418 FWTD-3-7118 FWTD-3-81118 FWTD-3-9618 FWTD-1-4018 FWTD-1-5018 FWTD-1-5418 FWTD-1-6018 FWTD-1-6418 FWTD-1-7018 FWTD-1-71118 FWTD-1-8018 FWTD-1-81118 FWTD-1-9618 FWTD-1-2120 FWTD-1-2720 FWTD-1-2920 FWTD-1-3120 FWTD-1-3320 FWTD-1-3520 FWTD-1-4020 FWTD-1-5020 FWTD-1-5420 FWTD-1-6020 FWTD-1-6420 FWTD-1-7020 FWTD-1-2124 FWTD-1-2724 FWTD-1-2924 FWTD-1-3124 FWTD-1-3324 FWTD-2-5024	FWTD-2-5424 FWTD-2-6024 FWTD-2-6424 FWTD-3-7124 FWTD-3-81124 FWTD-3-9624 FWTD-1-4024 FWTD-1-5024 FWTD-1-5424 FWTD-1-6024	FWTD-1-6424 FWTD-1-7024 FWTD-1-71124 FWTD-1-8024 FWTD-1-81124 FWTD-3-9624 FWTD-1-4024 FWTD-1-5024 FWTD-1-5424 FWTD-1-6024												
			A-Series Patio Door Transoms Direct-Set	FWTDS81110 FWTDS9610	FWTDS2110 FWTDS2710 FWTDS2910 FWTDS3110 FWTDS3310 FWTDS4010 FWTDS5010 FWTDS5410 FWTDS6010	FWTDS6410 FWTDS7010 FWTDS71110 FWTDS8010 FWTDS2114 FWTDS2714 FWTDS2914 FWTDS3114 FWTDS3314	FWTDS4014 FWTDS5014 FWTDS5414 FWTDS6014 FWTDS6414 FWTDS7014 FWTDS71114 FWTDS8014 FWTDS81114	FWTDS9614 FWTDS2118 FWTDS2718 FWTDS2918 FWTDS5018 FWTDS5418 FWTDS6018 FWTDS6418	FWTDS3118 FWTDS3318 FWTDS4018 FWTDS71118 FWTDS8018 FWTDS81118 FWTDS9618 FWTDS2120	FWTDS2720 FWTDS2920 FWTDS3120 FWTDS3320 FWTDS4020 FWTDS5020 FWTDS5420 FWTDS6020 FWTDS2124	FWTDS6020 FWTDS7020 FWTDS71120 FWTDS8020 FWTDS81120 FWTDS9620 FWTDS2724 FWTDS2924 FWTDS3124	FWTDS3324 FWTDS4024 FWTDS5024 FWTDS5424 FWTDS6024 FWTDS6424 FWTDS7024 FWTDS71124 FWTDS8024 FWTDS81124 FWTDS8124									
				A-Series Patio Door Sidelight Transoms		FWSLTD-1-1310 FWSLTD-1-1710 FWSLTD-1-1314 FWSLTD-1-1714 FWSLTD-1-1318	FWSLTD-1-1718 FWSLTD-1-1320 FWSLTD-1-1720 FWSLTD-1-1324 FWSLTD-1-1724	FWSTDS1310 FWSTDS1710 FWSTDS1314 FWSTDS1714 FWSTDS1318	FWSTDS1718 FWSTDS1320 FWSTDS1720 FWSTDS1324 FWSTDS1724												
					A-Series Patio Door Sidelights					FWSLD1368 FWSLD13611 FWSLD1380	FWSLD1768 FWSLD17611 FWSLD1780										
						A-Series Patio Doors															

**Combination Designs,
Product Performance
& Installation**

*Deflection of glass will occur on units with larger glass areas. If interior/exterior grilles are used on double-hung windows, gliding windows or gliding patio doors, some interference may occur, affecting operation of these units.
 *Altitude limits for patio doors shown in two-panel configurations. These limits also qualify for same size panels used in single or multiple panel configurations.
 •Contact your Andersen supplier for altitude limits for custom-sized windows and doors.

Andersen® Window and Patio Door Altitude Limits – Triple-Pane Glass (continued)

Product	3,000			4,000			5,000			6,000			7,000		8,000		9,000		10,000	
A-Series Fixed Transom Windows	ATF1410	ATF4414	ATF1816	ATF5018	ATF20110	ATF5020	ATF3222	ATF4424	ATF3426	ATF2674	ATF5028	ATF3038	ATF3058	ATF3464	ATF4080	ATF3870	ATF4444	ATF5480		
	ATF1810	ATF4814	ATF2016	ATF5418	ATF24110	ATF5420	ATF3422	ATF4824	ATF3826	ATF2678	ATF5428	ATF3040	ATF3060	ATF3468	ATF7840	ATF4040	ATF4448	ATF5854		
	ATF2010	ATF5014	ATF2416	ATF5818	ATF26110	ATF5820	ATF3822	ATF5024	ATF4026	ATF2680	ATF5828	ATF3044	ATF3064	ATF6434	ATF8040	ATF4044	ATF4450	ATF5858		
	ATF2410	ATF5414	ATF2616	ATF6018	ATF28110	ATF6020	ATF4022	ATF5424	ATF4426	ATF2828	ATF6028	ATF3048	ATF3068	ATF6834	ATF4470	ATF4048	ATF4454	ATF5860		
	ATF2610	ATF5814	ATF2816	ATF6418	ATF210110	ATF6420	ATF4422	ATF5824	ATF4826	ATF21028	ATF6428	ATF3050	ATF3070	ATF7838	ATF4474	ATF4050	ATF4458	ATF5864		
	ATF2810	ATF6014	ATF21016	ATF6818	ATF30110	ATF6820	ATF4822	ATF6024	ATF5026	ATF3028	ATF6828	ATF3054	ATF5830	ATF7840	ATF4478	ATF4054	ATF4460	ATF5868		
	ATF21010	ATF6414	ATF3016	ATF7018	ATF32110	ATF7020	ATF5022	ATF6424	ATF5426	ATF3228	ATF7028	ATF3230	ATF6030	ATF7844	ATF4480	ATF4058	ATF4464	ATF5870		
	ATF3010	ATF6814	ATF3216	ATF7418	ATF34110	ATF7420	ATF5422	ATF6824	ATF5826	ATF3428	ATF7428	ATF3430	ATF6430	ATF7848	ATF4484	ATF4064	ATF4468	ATF5874		
	ATF3210	ATF7014	ATF3416	ATF7818	ATF38110	ATF7820	ATF5822	ATF7024	ATF6026	ATF3828	ATF7828	ATF3830	ATF6830	ATF7850	ATF4488	ATF4070	ATF4474	ATF5878		
	ATF3410	ATF7414	ATF3816	ATF8018	ATF40110	ATF8020	ATF6022	ATF7424	ATF6426	ATF4028	ATF8028	ATF4030	ATF3260	ATF7854	ATF4494	ATF4074	ATF4478	ATF5880		
	ATF3810	ATF7814	ATF4016	ATF8418	ATF44110	ATF8420	ATF6422	ATF7824	ATF6826	ATF4428	ATF8428	ATF4430	ATF3264	ATF7858	ATF4498	ATF4078	ATF4482	ATF5884		
	ATF4010	ATF8014	ATF4416	ATF8818	ATF48110	ATF8820	ATF6822	ATF8424	ATF7026	ATF4828	ATF8828	ATF4434	ATF3268	ATF7862	ATF4504	ATF4084	ATF4486	ATF5888		
	ATF4410	ATF8414	ATF4816	ATF9018	ATF50110	ATF9020	ATF7022	ATF8424	ATF7426	ATF4828	ATF9028	ATF4436	ATF3270	ATF7866	ATF4508	ATF4088	ATF4490	ATF5890		
	ATF4810	ATF8814	ATF5016	ATF9418	ATF54110	ATF9420	ATF7422	ATF9024	ATF7826	ATF5030	ATF9428	ATF4438	ATF3274	ATF7870	ATF4514	ATF4094	ATF4494	ATF5894		
	ATF5010	ATF9014	ATF5416	ATF9818	ATF58110	ATF9820	ATF7822	ATF9424	ATF8026	ATF5430	ATF9828	ATF4440	ATF3278	ATF7874	ATF4518	ATF4098	ATF4498	ATF5898		
	ATF5410	ATF9414	ATF5816	ATF10018	ATF60110	ATF10020	ATF8022	ATF9424	ATF8426	ATF5430	ATF10028	ATF4442	ATF3282	ATF7878	ATF4524	ATF4104	ATF4504	ATF5900		
	ATF5810	ATF9814	ATF6016	ATF10418	ATF64110	ATF10420	ATF8422	ATF9824	ATF8826	ATF5434	ATF10428	ATF4444	ATF3286	ATF7882	ATF4528	ATF4108	ATF4508	ATF5904		
	ATF6010	ATF10014	ATF6416	ATF10818	ATF68110	ATF10820	ATF8822	ATF10024	ATF9026	ATF5436	ATF10828	ATF4446	ATF3290	ATF7886	ATF4534	ATF4114	ATF4514	ATF5908		
	ATF6410	ATF10414	ATF6816	ATF11218	ATF70110	ATF11220	ATF9022	ATF10424	ATF9426	ATF5438	ATF11228	ATF4448	ATF3294	ATF7890	ATF4540	ATF4120	ATF4518	ATF5910		
	ATF6810	ATF10814	ATF7016	ATF11618	ATF74110	ATF11620	ATF9422	ATF10824	ATF9826	ATF5440	ATF11628	ATF4450	ATF3298	ATF7894	ATF4546	ATF4126	ATF4524	ATF5914		
	ATF7010	ATF11214	ATF7416	ATF12018	ATF78110	ATF12020	ATF9822	ATF11224	ATF10026	ATF5442	ATF12028	ATF4452	ATF3302	ATF7898	ATF4552	ATF4132	ATF4530	ATF5918		
	ATF7410	ATF11614	ATF7816	ATF12418	ATF80110	ATF12420	ATF10022	ATF11624	ATF10426	ATF5444	ATF12428	ATF4454	ATF3306	ATF7902	ATF4558	ATF4138	ATF4536	ATF5920		
	ATF7810	ATF12014	ATF8016	ATF12818	ATF84110	ATF12820	ATF10422	ATF12024	ATF10826	ATF5446	ATF12828	ATF4456	ATF3310	ATF7906	ATF4564	ATF4144	ATF4542	ATF5924		
	ATF8010	ATF12414	ATF8416	ATF13218	ATF88110	ATF13220	ATF10822	ATF12424	ATF11226	ATF5448	ATF13228	ATF4458	ATF3314	ATF7910	ATF4570	ATF4150	ATF4548	ATF5928		
	ATF8410	ATF12814	ATF8816	ATF13618	ATF90110	ATF13620	ATF11222	ATF12824	ATF11626	ATF5450	ATF13628	ATF4460	ATF3318	ATF7914	ATF4576	ATF4156	ATF4554	ATF5930		
	ATF8810	ATF13214	ATF9016	ATF14018	ATF94110	ATF14020	ATF11622	ATF13224	ATF12026	ATF5452	ATF14028	ATF4462	ATF3322	ATF7918	ATF4582	ATF4162	ATF4560	ATF5934		
	ATF9010	ATF13614	ATF9416	ATF14418	ATF98110	ATF14420	ATF12022	ATF13624	ATF12426	ATF5454	ATF14428	ATF4464	ATF3326	ATF7922	ATF4588	ATF4168	ATF4566	ATF5938		
	ATF9410	ATF14014	ATF9816	ATF14818	ATF100110	ATF14820	ATF12422	ATF14024	ATF12826	ATF5456	ATF14828	ATF4466	ATF3330	ATF7926	ATF4594	ATF4174	ATF4574	ATF5940		
	ATF9810	ATF14414	ATF10016	ATF15218	ATF104110	ATF15220	ATF12822	ATF14424	ATF13226	ATF5458	ATF15228	ATF4468	ATF3334	ATF7930	ATF4600	ATF4180	ATF4582	ATF5944		
	ATF10010	ATF14814	ATF10416	ATF15618	ATF108110	ATF15620	ATF13222	ATF14824	ATF13626	ATF5460	ATF15628	ATF4470	ATF3338	ATF7934	ATF4606	ATF4186	ATF4590	ATF5948		
	ATF10410	ATF15214	ATF10816	ATF16018	ATF112110	ATF16020	ATF13622	ATF15224	ATF14026	ATF5462	ATF16028	ATF4472	ATF3342	ATF7938	ATF4612	ATF4192	ATF4598	ATF5950		
	ATF10810	ATF15614	ATF11216	ATF16418	ATF116110	ATF16420	ATF14022	ATF15624	ATF14426	ATF5464	ATF16428	ATF4474	ATF3346	ATF7942	ATF4618	ATF4198	ATF4606	ATF5954		
	ATF11210	ATF16014	ATF11616	ATF16818	ATF120110	ATF16820	ATF14422	ATF16024	ATF14826	ATF5466	ATF16828	ATF4476	ATF3350	ATF7946	ATF4624	ATF4204	ATF4614	ATF5958		
	ATF11610	ATF16414	ATF12016	ATF17218	ATF124110	ATF17220	ATF14822	ATF16424	ATF15226	ATF5468	ATF17228	ATF4478	ATF3354	ATF7950	ATF4630	ATF4210	ATF4622	ATF5960		
	ATF12010	ATF16814	ATF12416	ATF17618	ATF128110	ATF17620	ATF15222	ATF16824	ATF15626	ATF5470	ATF17628	ATF4480	ATF3358	ATF7954	ATF4636	ATF4216	ATF4630	ATF5964		
	ATF12410	ATF17214	ATF12816	ATF18018	ATF132110	ATF18020	ATF15622	ATF17224	ATF16026	ATF5472	ATF18028	ATF4482	ATF3362	ATF7958	ATF4642	ATF4222	ATF4636	ATF5968		
	ATF12810	ATF17614	ATF13216	ATF18418	ATF136110	ATF18420	ATF16022	ATF17624	ATF16426	ATF5474	ATF18428	ATF4484	ATF3366	ATF7962	ATF4648	ATF4228	ATF4642	ATF5970		
	ATF13210	ATF18014	ATF13616	ATF18818	ATF140110	ATF18820	ATF16422	ATF18024	ATF16826	ATF5476	ATF18828	ATF4486	ATF3370	ATF7966	ATF4654	ATF4234	ATF4648	ATF5974		
	ATF13610	ATF18414	ATF14016	ATF19218	ATF144110	ATF19220	ATF16822	ATF18424	ATF17226	ATF5478	ATF19228	ATF4488	ATF3374	ATF7970	ATF4660	ATF4240	ATF4654	ATF5978		
	ATF14010	ATF18814	ATF14416	ATF19618	ATF148110	ATF19620	ATF17222	ATF18824	ATF17626	ATF5480	ATF19628	ATF4490	ATF3378	ATF7974	ATF4666	ATF4246	ATF4660	ATF5980		
ATF14410	ATF19214	ATF14816	ATF20018	ATF152110	ATF20020	ATF17622	ATF19224	ATF18026	ATF5482	ATF20028	ATF4492	ATF3382	ATF7978	ATF4672	ATF4252	ATF4666	ATF5984			
ATF14810	ATF19614	ATF15216	ATF20418	ATF156110	ATF20420	ATF18022	ATF19624	ATF18426	ATF5484	ATF20428	ATF4494	ATF3386	ATF7982	ATF4678	ATF4258	ATF4672	ATF5988			
ATF15210	ATF20014	ATF15616	ATF20818	ATF160110	ATF20820	ATF18422	ATF19624	ATF18826	ATF5486	ATF20828	ATF4496	ATF3390	ATF7986	ATF4684	ATF4264	ATF4678	ATF5990			
ATF15610	ATF20414	ATF16016	ATF21218	ATF164110	ATF21220	ATF18822	ATF20024	ATF19226	ATF5488	ATF21228	ATF4498	ATF3394	ATF7990	ATF4690	ATF4270	ATF4684	ATF5994			
ATF16010	ATF20814	ATF16416	ATF21618	ATF168110	ATF21620	ATF19222	ATF20424	ATF19626	ATF5490	ATF21628	ATF4500	ATF3398	ATF7994	ATF4696	ATF4276	ATF4690	ATF5998			
ATF16410	ATF21214	ATF16816	ATF22018	ATF172110	ATF22020	ATF19622	ATF20824	ATF20026	ATF5492	ATF22028	ATF4502	ATF3402	ATF7998	ATF4702	ATF4282	ATF4696	ATF6000			
ATF16810	ATF21614	ATF17216	ATF22418	ATF176110	ATF22420	ATF20022	ATF21224	ATF20426	ATF5494	ATF22428	ATF4504	ATF3406	ATF8000	ATF4708	ATF4288	ATF4700	ATF6004			
ATF17210	ATF22014	ATF17616	ATF22818	ATF180110	ATF22820	ATF20422	ATF21624	ATF20826	ATF5496	ATF22828	ATF4506	ATF3410	ATF8004	ATF4714	ATF4294	ATF4706	ATF6008			
ATF17610	ATF22414	ATF18016	ATF23218	ATF184110	ATF23220	ATF20822	ATF22024	ATF21226	ATF5498	ATF23228	ATF4508	ATF3414	ATF8008	ATF4720	ATF4300	ATF4712	ATF6012			
ATF18010	ATF22814	ATF18416	ATF23618	ATF188110	ATF23620	ATF21222	ATF22424	ATF21626	ATF5500	ATF23628	ATF4510	ATF3418	ATF8012	ATF4726	ATF4306	ATF4718	ATF6016			
ATF18410	ATF23214	ATF18816	ATF24018	ATF192110	ATF24020	ATF21622	ATF22824	ATF22026	ATF5502	ATF24028	ATF4512	ATF3422	ATF8016	ATF4732	ATF4312	ATF4724	ATF6020			
ATF18810	ATF23614	ATF19216	ATF24418	ATF196110	ATF24420	ATF22022	ATF23224	ATF22426	ATF5504	ATF24428	ATF4514	ATF3426	ATF8020	ATF4738	ATF4318	ATF4730	ATF6024			
ATF19210	ATF24014	ATF19616	ATF24818	ATF200110	ATF24820	ATF22422	ATF23624	ATF22826	ATF5506	ATF24828	ATF4516	ATF3430	ATF8024	ATF4744	ATF4324	ATF4736	ATF6028			
ATF19610	ATF24414	ATF20016	ATF25218	ATF204110	ATF25220	ATF22822	ATF24024	ATF23226	ATF5508	ATF25228	ATF4518	ATF3434	ATF8028	ATF4750	ATF4330	ATF4742	ATF6032			
ATF20010	ATF24814	ATF20416	ATF25618	ATF208110	ATF25620	ATF23222	ATF24424	AT												

PRODUCT PERFORMANCE

PERFORMANCE STANDARDS

The Window and Door Manufacturers Association (WDMA), the American Architectural Manufacturers Association (AAMA) and the Canadian Standards Association (CSA) jointly release the North American Fenestration Standard/Specification for Windows, Doors and Skylights (NAFS-11) where “-11” refers to the most recent publication year of 2011. NAFS is also referred to as AAMA/WDMA/CSA 101/I.S.2/A440, which is how the International Code Council (ICC) lists this standard in the 2012, 2015 and 2018 International Residential Code (IRC) and International Building Code (IBC) as the means to indicate the window, door or skylights design pressure rating used to determine compliance to the job site design pressure requirements.

A product only achieves a “Performance Grade” or “PG” rating when it complies with all of the NAFS performance requirements such as ease of operation, air infiltration resistance, resistance to water penetration and resistance to forced entry, etc. A “Design Pressure Rating” or “DP” rating only depicts the design and structural load performance.

Performance Classes

The NAFS Standard/Specification defines requirements for four performance classes. Performance classes are designated R, LC, CW and AW. This classification system provides for several levels of performance. Product selection is always based on the performance and building code requirements of the particular project.

Elements of Performance Grade (PG) Designations

In order to qualify for a given performance grade (PG), test specimens need to pass all required performance tests for the following, in addition to all required auxiliary (durability) and applicable material/component tests (not shown here) for the applicable product type and desired performance class:

- (a) Operating force (if applicable):** Maximum operating force varies by product type and performance class.
- (b) Air leakage resistance:** Tested in accordance with ASTM E283 at a test pressure of 1.57 psf. Allowable air infiltration for R, LC and CW class designations is 0.3 cubic feet per minute per square foot of frame (cfm/ft²).
- (c) Water penetration resistance:** Tested in accordance with ASTM E547 with the specified test pressure applied per NAFS-11. Test consists of four cycles. Each cycle consists of five minutes with pressure applied and one minute with the pressure released, during which the water spray is continuously applied. Water spray shall be uniformly applied at a constant rate of 5 U.S. gal/ft² · hr.
- (d) Uniform load deflection test:** Tested in accordance with ASTM E330 for both positive and negative pressure (pressure defined by NAFS-11) with the load maintained for a period of 10 seconds. The test specimen shall be evaluated for deflection during each load for permanent damage after each load and for any effects on the normal operation of the specimen. *Starting with the 2008 version of NAFS, design pressure (DP) will only represent the “uniform load deflection test.”*
- (e) Uniform load structural test:** Tested in accordance with ASTM E330 for both positive and negative pressure (pressure defined by NAFS-11) with the load maintained for a period of 10 seconds. After loads are removed, there shall be no permanent deformation in excess of 0.4% of its span and no damage to the unit, which would make it inoperable.
- (f) Forced-entry resistance (if applicable):** Tested in accordance with ASTM F588 (windows), F476 (swinging doors) and F842 (sliding doors) at a performance level 10 rating.

Performance Grades (PG) and Corresponding Test Pressures (psf)

Performance Class/ Performance Grade		Air Infiltration Test Pressure		Maximum Allowable Air Infiltration/Exfiltration Rate		Water Penetration Resistance Test Pressure		Design Pressure		Structural Test Pressure	
R	LC	Pa	psf	L/s·m ²	cfm/ft ²	Pa	psf	Pa	psf	Pa	psf
15	-	75	1.57	1.5	0.30	140	2.92	720	15.04	1080	22.56
20	-	75	1.57	1.5	0.30	150	3.13	960	20.05	1440	30.08
25	25	75	1.57	1.5	0.30	180	3.76	1200	25.06	1800	37.59
30	30	75	1.57	1.5	0.30	220	4.59	1440	30.08	2160	45.11
35	35	75	1.57	1.5	0.30	260	5.43	1680	35.09	2520	52.63
40	40	75	1.57	1.5	0.30	290	6.06	1920	40.10	2880	60.15
45	45	75	1.57	1.5	0.30	330	6.89	2160	45.11	3240	67.67
50	50	75	1.57	1.5	0.30	360	7.52	2400	50.13	3600	75.19
55	55	75	1.57	1.5	0.30	400	8.35	2640	55.14	3960	82.71
60	60	75	1.57	1.5	0.30	440	9.19	2880	60.15	4320	90.23
65	65	75	1.57	1.5	0.30	470	9.82	3120	65.16	4680	97.74
70	70	75	1.57	1.5	0.30	510	10.65	3360	70.18	5040	105.26
75	75	75	1.57	1.5	0.30	540	11.28	3600	75.19	5400	112.78
80	80	75	1.57	1.5	0.30	580	12.11	3840	80.20	5760	120.30
85	85	75	1.57	1.5	0.30	620	12.94	4080	85.21	6120	127.82
90	90	75	1.57	1.5	0.30	660	13.78	4320	90.23	6480	135.34
95	95	75	1.57	1.5	0.30	682	14.25	4560	95.24	6840	142.86
100	100	75	1.57	1.5	0.30	718	15.00	4800	100.25	7200	150.38

HALLMARK CERTIFICATION

The Window and Door Manufacturers Association (WDMA)-sponsored Hallmark Certification Program provides manufacturers with certification to the AAMA/WDMA/CSA 101/I.S.2/A440-11 Standard and is designed to provide builders, architects, specifiers and consumers with an easily recognizable means of identifying products that have been manufactured and tested in accordance with NAFS (AAMA/WDMA/CSA 101/I.S.2/A440) industry standards and other applicable performance standards. Conformance is determined by periodic in-plant inspections by a third-party administrator. Inspections include auditing licensee quality control procedures and processes, and a review to confirm products are manufactured in accordance with the appropriate performance standards. Periodic testing of representative product constructions and components by an independent testing laboratory is also required. When all of the program requirements are met, the licensee is authorized to use the WDMA Hallmark registered logo on their certification label as a means of identifying products and their performance ratings.

Products successfully obtaining Hallmark Certification will be labeled with a three-part code, which includes performance class, performance grade and size tested. In addition to this mandatory requirement, you are allowed to list the design pressure on a separate line.

	Andersen Corporation A-SERIES CASEMENT WINDOW Manufacturer stipulates certification as indicated below.					
	<table border="1"> <thead> <tr> <th>STANDARD</th> <th>RATING</th> </tr> </thead> <tbody> <tr> <td>AAMA/WDMA/CSA 101/I.S.2/A440-11</td> <td>CLASS LC⁽¹⁾ - PG50⁽²⁾ - SIZE TESTED 35.3 x 71.3 in.⁽³⁾ DP+50/-50⁽⁴⁾</td> </tr> <tr> <td>AAMA/WDMA/CSA 101/I.S.2/A440-08</td> <td>CLASS LC⁽¹⁾ - PG50⁽²⁾ - SIZE TESTED 35.3 x 71.3 in.⁽³⁾ DP+50/-50⁽⁴⁾</td> </tr> </tbody> </table>	STANDARD	RATING	AAMA/WDMA/CSA 101/I.S.2/A440-11	CLASS LC ⁽¹⁾ - PG50 ⁽²⁾ - SIZE TESTED 35.3 x 71.3 in. ⁽³⁾ DP+50/-50 ⁽⁴⁾	AAMA/WDMA/CSA 101/I.S.2/A440-08
STANDARD	RATING					
AAMA/WDMA/CSA 101/I.S.2/A440-11	CLASS LC ⁽¹⁾ - PG50 ⁽²⁾ - SIZE TESTED 35.3 x 71.3 in. ⁽³⁾ DP+50/-50 ⁽⁴⁾					
AAMA/WDMA/CSA 101/I.S.2/A440-08	CLASS LC ⁽¹⁾ - PG50 ⁽²⁾ - SIZE TESTED 35.3 x 71.3 in. ⁽³⁾ DP+50/-50 ⁽⁴⁾					

- (1) - Performance Class
- (2) - Performance Grade
- (3) - Size Tested
- (4) - Design Pressure

In the example above, the performance class is LC, the performance grade (PG) is 50 pounds per square foot (psf) and the size tested is 35.3" x 71.3". What this means to the specifier is, based on the performance grade chart, the laboratory-tested air infiltration was less than 0.3 cfm/ft² (test pressure is always 1.57 psf and the allowable airflow is 0.3 cfm/ft²), the product tested successfully resisted a laboratory water penetration test at a test pressure of 7.5 psf, the product tested successfully withstood a laboratory positive test pressure of 75 psf and a laboratory negative test pressure of 75 psf, and the product tested passed the laboratory requirements for operational force and forced-entry resistance. Based on this test, all products of the same design that are smaller than the tested size can be labeled with this product performance rating.

IMPORTANT

Building codes prescribe design pressure based on a variety of criteria (i.e., windspeed zone, building height, building type, job site exposure, etc.). Design pressures derived from Performance Grade (PG) test requirements should be used to determine compliance to building code required design pressures. Structural test pressures, which are tested at 1.5 times the design pressure, should not be used for determining design pressure code compliance. In the example above, a PG 50 performance grade rating, which passes a 50 psf design pressure, should be used for determining code compliance, not the structural test pressure of 75 psf.

If you need further details about how Andersen® products perform to this standard, contact your Andersen supplier.

If you need further information about the AAMA/WDMA/CSA 101/I.S.2/A440-11 standard or the Hallmark Certification Program, please contact: WDMA, 2001 K Street NW, 3rd Floor North, Washington, D.C. 20006. Phone: 202-367-1157. Website: wdma.com

Where designated, Andersen products are tested, certified and labeled to the requirements of the Hallmark Certification Program. Actual performance may vary based on variations in manufacturing, shipping, installation, environmental conditions and conditions of use.

Performance Grade and Air Infiltration – A-Series Windows and Patio Doors

 For current performance information, please visit andersenwindows.com.

Andersen® Product	Glass Construction	AAMA/WDMA/CSA 101/I.S.2/A440 Performance Grade (PG)	+/- Corresponding Design Pressure (DP)	Air Infiltration CFM/FT ²
Casement Windows				
Casement (venting/stationary)	Dual-Pane	Class LC-PG50 Size Tested 47" x 95"	50/50	< 0.2
Casement, PG Upgrade (venting/stationary)	Dual-Pane	Class LC-PG70 Size Tested 35" x 95"	70/70	< 0.2
Casement, PG Upgrade (stationary)	Dual-Pane	Class LC-PG70 Size Tested 47" x 47"	70/70	< 0.2
Casement, PG Upgrade (stationary)	Dual-Pane	Class LC-PG60 Size Tested 47" x 95"	60/60	< 0.2
Casement, PG Upgrade (venting)	Dual-Pane	Class LC-PG60 Size Tested 47" x 46"	60/60	< 0.2
Casement, PG Upgrade (venting)	Dual-Pane	Class LC-PG70 Size Tested 47" x 47"	70/70	< 0.2
Casement, PG Upgrade (venting)	Dual-Pane	Class LC-PG60 Size Tested 39" x 95"	60/60	< 0.2
Casement, PG Upgrade (venting)	Dual-Pane	Class LC-PG60 Size Tested 41" x 71"	60/60	< 0.2
Awning Windows				
Awning (venting/stationary)	Dual-Pane	Class LC-PG50 Size Tested 71" x 47"	50/50	< 0.2
Awning, PG Upgrade (stationary)	Dual-Pane	Class LC-PG70 Size Tested 71" x 47"	70/70	< 0.2
Awning, PG Upgrade (venting)	Dual-Pane	Class LC-PG70 Size Tested 47" x 47"	70/70	< 0.2
Awning, PG Upgrade (venting)	Dual-Pane	Class LC-PG60 Size Tested 59" x 47"	60/60	< 0.2
Awning, PG Upgrade (venting)	Dual-Pane	Class LC-PG60 Size Tested 71" x 31"	60/60	< 0.2
Double-Hung Windows				
Double-Hung	Dual-Pane	Class LC-PG50 Size Tested 47" x 95"	50/50	< 0.2
Double-Hung, PG Upgrade	Dual-Pane	Class LC-PG70 Size Tested 47" x 95"	70/70	< 0.2
Picture Windows				
Picture	Dual-Pane	Class LC-PG50 Size Tested 71" x 95"	50/50	< 0.2
Picture, PG Upgrade	Dual-Pane	Class LC-PG70 Size Tested 71" x 95"	70/70	< 0.2
Transom Windows				
Fixed Transom	Dual-Pane	Class LC-PG50 Size Tested 71" x 95"	50/50	< 0.2
Fixed Transom, PG Upgrade	Dual-Pane	Class LC-PG70 Size Tested 71" x 95"	70/70	< 0.2
Venting Transom	Dual-Pane	Class LC-PG50 Size Tested 71" x 31"	50/50	< 0.2
Venting Transom, PG Upgrade (stationary)	Dual-Pane	Class LC-PG70 Size Tested 71" x 31"	70/70	< 0.2
Venting Transom, PG Upgrade (venting)	Dual-Pane	Class LC-PG70 Size Tested 59" x 31"	70/70	< 0.2
Venting Transom, PG Upgrade (venting)	Dual-Pane	Class LC-PG60 Size Tested 71" x 31"	60/60	< 0.2
Direct-Set Specialty Windows				
Rectangle	Dual-Pane	Class LC-PG50 Size Tested 125" x 84"	50/50	< 0.2
Rectangle, PG Upgrade	Dual-Pane	Class LC-PG70 Size Tested 125" x 84"	70/70	< 0.2
Arch	Dual-Pane	Class LC-PG50 Size Tested 125" x 84"	50/50	< 0.2
Arch, PG Upgrade	Dual-Pane	Class LC-PG70 Size Tested 125" x 84"	70/70	< 0.2
Springline™	Dual-Pane	Class LC-PG50 Size Tested 84" x 125"	50/50	< 0.2
Springline, PG Upgrade	Dual-Pane	Class LC-PG70 Size Tested 84" x 125"	70/70	< 0.2
Sash-Set Specialty Windows				
Rectangular	Dual-Pane	Class LC-PG50 Size Tested 125" x 75"	50/50	< 0.2
Rectangular, PG Upgrade	Dual-Pane	Class LC-PG70 Size Tested 125" x 75"	70/70	< 0.2
Arch	Dual-Pane	Class LC-PG50 Size Tested 125" x 75"	50/50	< 0.2
Arch, PG Upgrade	Dual-Pane	Class LC-PG70 Size Tested 125" x 75"	70/70	< 0.2
Springline™	Dual-Pane	Class LC-PG50 Size Tested 75" x 125"	50/50	< 0.2
Springline, PG Upgrade	Dual-Pane	Class LC-PG70 Size Tested 75" x 125"	70/70	< 0.2
Complementary Casement Windows				
Casement (venting)	Dual-Pane	Class LC-PG50 Size Tested 35" x 84"	50/50	< 0.2
Casement (stationary)	Dual-Pane	Class LC-PG60 Size Tested 120" x 78"	60/60	< 0.2
French Casement (venting)	Dual-Pane	Class LC-PG30 Size Tested 56" x 72"	30/30	< 0.2

For sound transmission ratings, see page 214.

Combination Designs, Product Performance & Installation

• *Performance Grade (PG)* ratings may vary from tested performance rating for larger or smaller units of a particular type.
 • This data is accurate as of November 2022. Due to ongoing product changes, updated test results, or new industry standards, this data may change over time.
 • Where designated, Andersen products are certified and labeled to the requirements of the Hallmark Certification Program. Actual performance may vary based on variations in manufacturing, shipping, installation, environmental conditions and conditions of use.
 • Contact your Andersen supplier for more information.

continued on next page

PRODUCT PERFORMANCE

Performance Grade and Air Infiltration – A-Series Windows and Patio Doors (continued)

For current performance information, please visit andersenwindows.com.

Andersen® Product	Glass Construction	AAMA/WDMA/CSA 101/I.S.2/A440 Performance Grade (PG)	+/- Corresponding Design Pressure (DP)	Air Infiltration CFM/FT ²
Gliding Patio Doors				
Single Stationary (611, 80, 100)	Dual-Pane	Class LC-PG45 Size Tested 50" x 119"	45/45	< 0.2
Single Stationary, PG Upgrade (611, 80)	Dual-Pane	Class LC-PG65 Size Tested 50" x 95"	65/80	< 0.2
Single Stationary, PG Upgrade (100)	Dual-Pane	Class LC-PG55 Size Tested 50" x 119"	55/55	< 0.2
Two-Panel (611, 80)	Dual-Pane	Class LC-PG50 Size Tested 95" x 95"	50/50	< 0.2
Two-Panel (100)	Dual-Pane	Class LC-PG45 Size Tested 95" x 119"	45/45	< 0.2
Two-Panel, PG Upgrade (611)	Dual-Pane	Class LC-PG70 Size Tested 95" x 82"	70/80	< 0.2
Two-Panel, PG Upgrade (80)	Dual-Pane	Class LC-PG70 Size Tested 95" x 95"	70/70	< 0.2
Two-Panel, PG Upgrade (100)	Dual-Pane	Class LC-PG55 Size Tested 95" x 119"	55/55	< 0.2
Three-Panel (611)	Dual-Pane	Class LC-PG50 Size Tested 141" x 82"	50/50	< 0.2
Three-Panel (80, 100)	Dual-Pane	Class LC-PG40 Size Tested 141" x 119"	40/40	< 0.2
Three-Panel, PG Upgrade (611)	Dual-Pane	Class LC-PG65 Size Tested 141" x 82"	65/70	< 0.2
Three-Panel, PG Upgrade (80, 100)	Dual-Pane	Class LC-PG50 Size Tested 141" x 119"	50/50	< 0.2
Four-Panel (611)	Dual-Pane	Class LC-PG50 Size Tested 189" x 82"	50/50	< 0.2
Four-Panel (80, 100)	Dual-Pane	Class LC-PG40 Size Tested 189" x 119"	40/40	< 0.2
Four-Panel, PG Upgrade (611)	Dual-Pane	Class LC-PG65 Size Tested 189" x 82"	65/70	< 0.2
Four-Panel, PG Upgrade (80, 100)	Dual-Pane	Class LC-PG50 Size Tested 189" x 119"	50/50	< 0.2
Hinged Inswing Patio Doors				
Single Stationary (611, 80, 100)	Dual-Pane	Class LC-PG45 Size Tested 38" x 119"	45/55	< 0.2
Single Stationary, PG Upgrade (611)	Dual-Pane	Class LC-PG65 Size Tested 38" x 82"	65/80	< 0.2
Single Stationary, PG Upgrade (80, 100)	Dual-Pane	Class LC-PG65 Size Tested 38" x 119"	65/70	< 0.2
Single Active (611, 80, 100)	Dual-Pane	Class LC-PG45 Size Tested 38" x 119"	45/55	< 0.2
Single Active, PG Upgrade (611)	Dual-Pane	Class LC-PG65 Size Tested 38" x 82"	65/80	< 0.2
Single Active, PG Upgrade (80, 100)	Dual-Pane	Class LC-PG65 Size Tested 38" x 119"	65/70	< 0.2
Two-Panel AP/PA (611, 80, 100)	Dual-Pane	Class LC-PG45 Size Tested 75" x 119"	45/55	< 0.2
Two-Panel AP/PA, PG Upgrade (611)	Dual-Pane	Class LC-PG65 Size Tested 75" x 82"	65/80	< 0.2
Two-Panel AP/PA, PG Upgrade (80)	Dual-Pane	Class LC-PG65 Size Tested 75" x 95"	65/70	< 0.2
Two-Panel AP/PA, PG Upgrade (100)	Dual-Pane	Class LC-PG50 Size Tested 75" x 119"	50/65	< 0.2
Two-Panel AS/SA/SS (611, 80)	Dual-Pane	Class LC-PG45 Size Tested 71" x 95"	45/55	< 0.2
Two-Panel AS/SA/SS, PG Upgrade (611)	Dual-Pane	Class LC-PG65 Size Tested 75" x 82"	65/80	< 0.2
Two-Panel AS/SA/SS, PG Upgrade (80)	Dual-Pane	Class LC-PG65 Size Tested 75" x 95"	65/70	< 0.2
Three-Panel (611, 80)	Dual-Pane	Class LC-PG45 Size Tested 106" x 95"	45/55	< 0.2
Hinged Outswing Patio Doors				
Single Stationary (611, 80, 100)	Dual-Pane	Class LC-PG45 Size Tested 38" x 119"	45/55	< 0.2
Single Stationary, PG Upgrade (611, 80)	Dual-Pane	Class LC-PG65 Size Tested 38" x 95"	65/80	< 0.2
Single Stationary, PG Upgrade (100)	Dual-Pane	Class LC-PG65 Size Tested 38" x 119"	65/70	< 0.2
Single Active (611, 80, 100)	Dual-Pane	Class LC-PG45 Size Tested 38" x 119"	45/55	< 0.2
Single Active, PG Upgrade (611)	Dual-Pane	Class LC-PG65 Size Tested 38" x 82"	65/80	< 0.2
Single Active, PG Upgrade (80, 100)	Dual-Pane	Class LC-PG65 Size Tested 38" x 119"	65/70	< 0.2
Two-Panel (611, 80, 100)	Dual-Pane	Class LC-PG45 Size Tested 75" x 119"	45/45	< 0.2
Two Panel, PG Upgrade (611)	Dual-Pane	Class LC-PG65 Size Tested 75" x 82"	65/80	< 0.2
Two Panel, PG Upgrade (80)	Dual-Pane	Class LC-PG65 Size Tested 75" x 95"	65/70	< 0.2
Two Panel, PG Upgrade (100)	Dual-Pane	Class LC-PG55 Size Tested 75" x 119"	55/55	< 0.2

For sound transmission ratings, see page 214.

* "Performance Grade (PG)" ratings may vary from tested performance rating for larger or smaller units of a particular type.

* This data is accurate as of November 2022. Due to ongoing product changes, updated test results, or new industry standards, this data may change over time.

* Where designated, Andersen products are certified and labeled to the requirements of the Hallmark Certification Program. Actual performance may vary based on variations in manufacturing, shipping, installation, environmental conditions and conditions of use.

* Contact your Andersen supplier for more information.

continued on next page

Performance Grade and Air Infiltration – A-Series Windows and Patio Doors *(continued)*

 For current performance information, please visit andersenwindows.com.

Andersen® Product	Glass Construction	AAMA/WDMA/CSA 101/1.S.2/A440 Performance Grade (PG)	+/- Corresponding Design Pressure (DP)	Air Infiltration CFM/FT ²
Patio Door Transoms & Sidelights				
Transom	Dual-Pane	Class LC-PG70 Size Tested 112" x 27"	70/80	< 0.2
Sidelight Transom	Dual-Pane	Class LC-PG70 Size Tested 18" x 27"	70/70	< 0.2
Sidelight Transom, PG Upgrade	Dual-Pane	Class LC-PG70 Size Tested 18" x 27"	70/80	< 0.2
Sidelight (611, 80, 100)	Dual-Pane	Class LC-PG45 Size Tested 18" x 119"	45/70	< 0.2
Sidelight, PG Upgrade (611, 80, 100)	Dual-Pane	Class LC-PG70 Size Tested 18" x 119"	70/80	< 0.2
Complementary Springline™ & Arch Hinged Inswing Patio Doors				
Single Stationary	Dual-Pane	Class LC-PG45 Size Tested 75.3" x 95.5"	45/45	< 0.2
Single Active*	Dual-Pane	Class LC-PG45 Size Tested 37.9" x 95.5"	45/45	< 0.2
Two-Panel Stationary	Dual-Pane	Class LC-PG45 Size Tested 75.3" x 95.5"	45/45	< 0.2
Two-Panel Active*	Dual-Pane	Class LC-PG45 Size Tested 75.3" x 95.5"	45/45	< 0.2
Complementary Springline & Arch Hinged Outswing Patio Doors				
Single Stationary	Dual-Pane	Class LC-PG45 Size Tested 75.3" x 95.5"	45/45	< 0.2
Single Active*	Dual-Pane	Class LC-PG45 Size Tested 37.9" x 95.5"	45/45	< 0.2
Two-Panel Stationary	Dual-Pane	Class LC-PG45 Size Tested 75.3" x 95.5"	45/45	< 0.2
Two-Panel Active*	Dual-Pane	Class LC-PG45 Size Tested 75.3" x 95.5"	45/45	< 0.2

For sound transmission ratings, see page 214.

- *Performance Grade (PG) ratings may vary from tested performance rating for larger or smaller units of a particular type.
- *This data is accurate as of November 2022. Due to ongoing product changes, updated test results, or new industry standards, this data may change over time.
- *Where designated, Andersen products are certified and labeled to the requirements of the Hallmark Certification Program. Actual performance may vary based on variations in manufacturing, shipping, installation, environmental conditions and conditions of use.
- *Contact your Andersen supplier for more information.
- *Tested with standard multi-point hardware.

Andersen® Products Total Unit Recycled Content Percentages

 For current performance information, please visit andersenwindows.com.

Andersen® Product	% Pre-Consumer Recycled Content
A-Series Windows	
Casement	10%
Awning	10%
Double-Hung	10%
Picture	6%
Fixed Transom	5%
Venting Transom	10%
Specialty	5%
Complementary Casement	5%
A-Series Patio Doors	
Gliding	4%
Hinged Inswing	3%
Hinged Outswing	3%
Patio Door Sidelight	3%
Patio Door Transom	3%
Complementary Springline™ Hinged	3%
Complementary Arch Hinged	3%

- *“% Pre-Consumer Recycled Content” is calculated to meet ISO 14021 standards based on NFRC sizing. Actual recycled content dependent on product size.

Combination Designs, Product Performance & Installation

PRODUCT PERFORMANCE

Sound Transmission Ratings – A-Series Windows and Patio Doors

For current performance information, please visit andersenwindows.com.

Andersen® Product	Glass Construction	Sound Transmission Class (STC)	Outdoor/Indoor Transmission Class (OITC)
Casement Windows			
Casement	Dual-Pane	27	23
	Triple-Pane	30	25
Awning	Dual-Pane	†	†
	Triple-Pane	29	23
Double-Hung	Dual-Pane	27	22
	Triple-Pane	28	23
Picture	Dual-Pane	27	22
	Triple-Pane	30	25
Venting Transom	Dual-Pane	28	22
	Triple-Pane	28	23
Fixed Transom	Dual-Pane	27	22
	Triple-Pane	31	24
Direct-Set Specialty Windows			
Rectangular	Dual-Pane	28	24
Arch	Dual-Pane	28	24
Springline™	Dual-Pane	28	24
Sash-Set Specialty Windows			
Rectangular	Dual-Pane	29	24
Arch	Dual-Pane	29	24
Springline	Dual-Pane	29	24
Gliding Patio Doors			
Single Stationary	Dual-Pane	†	†
	Triple-Pane	32	28
Single Stationary, PG Upgrade	Dual-Pane	†	†
Two-Panel	Dual-Pane	†	†
	Triple-Pane	29	25
Two-Panel, PG Upgrade	Dual-Pane	†	†
Three-Panel	Dual-Pane	†	†
Three-Panel, PG Upgrade	Dual-Pane	†	†
Four-Panel	Dual-Pane	†	†
Four-Panel, PG Upgrade	Dual-Pane	†	†
Hinged Inswing Patio Doors			
Single Stationary	Dual-Pane	30	26
Single Stationary, PG Upgrade	Dual-Pane	30	26
Single Active	Dual-Pane	30	26
	Triple-Pane	31	25
Single Active, PG Upgrade	Dual-Pane	30	26
Two-Panel AP/PA	Dual-Pane	30	25
	Triple-Pane	31	25
Two-Panel AP/PA, PG Upgrade	Dual-Pane	30	25
Two-Panel AS/SA/SS	Dual-Pane	30	25
Two-Panel AS/SA/SS, PG Upgrade	Dual-Pane	30	25
Three-Panel	Dual-Pane	†	†

Andersen® Product	Glass Construction	Sound Transmission Class (STC)	Outdoor/Indoor Transmission Class (OITC)
Hinged Outswing Patio Doors			
Single Stationary	Dual-Pane	30	25
Single Stationary, PG Upgrade	Dual-Pane	30	25
Single Active	Dual-Pane	30	25
	Triple-Pane	31	25
Single Active, PG Upgrade	Dual-Pane	30	25
Two-Panel	Dual-Pane	31	25
	Triple-Pane	31	25
Two-Panel, PG Upgrade	Dual-Pane	31	25
Patio Door Sidelights and Transoms			
Transom	Dual-Pane	†	†
Sidelight Transom	Dual-Pane	†	†
Sidelight Transom, PG Upgrade	Dual-Pane	†	†
Sidelight	Dual-Pane	†	†
Sidelight, PG Upgrade	Dual-Pane	†	†
Complementary Springline™ & Arch Hinged Inswing Patio Doors			
Single Stationary	Dual-Pane	†	†
Single Active	Dual-Pane	30	25
Two-Panel Stationary	Dual-Pane	†	†
Two-Panel Active	Dual-Pane	30	25
Complementary Springline & Arch Hinged Outswing Patio Doors			
Single Stationary	Dual-Pane	†	†
Single Active	Dual-Pane	31	25
Two-Panel Stationary	Dual-Pane	†	†
Two-Panel Active	Dual-Pane	31	25

* "Sound Transmission Class (STC)" and "Outdoor/Indoor Transmission Class (OITC)" ratings are for individual units based on independent tests and represent entire unit.

* This data is accurate as of November 2022. Due to ongoing product changes, updated test results, or new industry standards, this data may change over time.

* Contact your Andersen supplier for more information.

† Data not available.

Center of Glass Performance Data – A-Series Windows and Patio Doors

 For current performance information, please visit andersenwindows.com.

DUAL-PANE	Low-E4® Dual-Pane Glass	VT ¹	SC ²	SHGC ³	RHG ⁴	Fading		%RH @ center ⁷	IGST ⁸
						Tuv ⁵	Tdw ⁶		
A-Series Products									
	Casement, Awning, Double-Hung, Picture, Transom & Specialty Windows	72%	0.48	0.41	98.2	16%	33%	61%	56°F
	Gliding, Hinged Inswing & Outswing Patio Doors, Patio Door Sidelights & Transoms	71%	0.47	0.41	97.5	16%	33%	61%	56°F
	Complementary Curved Top Patio Doors	65%	0.31	0.27	207	5%	21%	61%	56°F

DUAL-PANE	Low-E4® Sun Dual-Pane Glass	VT ¹	SC ²	SHGC ³	RHG ⁴	Fading		%RH @ center ⁷	IGST ⁸
						Tuv ⁵	Tdw ⁶		
A-Series Products									
	Casement, Awning, Double-Hung, Picture, Transom & Specialty Windows	40%	0.29	0.25	61.1	16%	24%	60%	55° F
	Gliding, Hinged Inswing & Outswing Patio Doors, Patio Door Sidelights & Transoms	39%	0.29	0.25	60.6	15%	23%	61%	56° F
	Complementary Curved Top Patio Doors	72%	0.48	0.41	310	16%	33%	61%	56°F

DUAL-PANE	Low-E4® SmartSun™ Dual-Pane Glass	VT ¹	SC ²	SHGC ³	RHG ⁴	Fading		%RH @ center ⁷	IGST ⁸
						Tuv ⁵	Tdw ⁶		
A-Series Products									
	Casement, Awning, Double-Hung, Picture, Transom & Specialty Windows	65%	0.31	0.27	65.6	5%	21%	62%	56° F
	Gliding, Hinged Inswing & Outswing Patio Doors, Patio Door Sidelights & Transoms	64%	0.32	0.27	66.3	5%	21%	62%	56° F
	Complementary Curved Top Patio Doors	40%	0.29	0.25	193	16%	24%	59%	55°F

TRIPLE-PANE	Low-E4® Triple-Pane Glass	VT ¹	SC ²	SHGC ³	RHG ⁴	Fading		%RH @ center ⁷	IGST ⁸
						Tuv ⁵	Tdw ⁶		
A-Series Products									
Low-E4									
	Casement, Awning, Double-Hung, Picture, Transom & Specialty Windows	66%	0.44	0.38	91.6	14%	30%	64%	57° F
	Gliding, Hinged Inswing & Outswing Patio Doors, Patio Door Sidelights & Transoms	66%	0.44	0.38	91.6	14%	30%	64%	57° F
Low-E4 Enhanced									
	Casement, Awning, Double-Hung, Picture, Transom & Specialty Windows	63%	0.43	0.37	88.6	8%	24%	71%	60° F
	Gliding, Hinged Inswing & Outswing Patio Doors, Patio Door Sidelights & Transoms	63%	0.43	0.37	88.6	8%	24%	71%	60° F
Low-E4 Enhanced with HeatLock® Technology									
	Casement, Awning, Double-Hung, Picture, Transom & Specialty Windows	62%	0.41	0.36	84.3	8%	23%	54%	52° F
	Gliding, Hinged Inswing & Outswing Patio Doors, Patio Door Sidelights & Transoms	63%	0.43	0.37	88.6	8%	24%	71%	60° F

TRIPLE-PANE	Low-E4® SmartSun™ Triple-Pane Glass	VT ¹	SC ²	SHGC ³	RHG ⁴	Fading		%RH @ center ⁷	IGST ⁸
						Tuv ⁵	Tdw ⁶		
A-Series Products									
SmartSun									
	Casement, Awning, Double-Hung, Picture, Transom & Specialty Windows	59%	0.29	0.26	62.0	4%	19%	65%	57° F
	Gliding, Hinged Inswing & Outswing Patio Doors, Patio Door Sidelights & Transoms	59%	0.29	0.26	62.0	4%	19%	65%	57° F
SmartSun Enhanced									
	Casement, Awning, Double-Hung, Picture, Transom & Specialty Windows	57%	0.29	0.25	59.6	2%	16%	71%	60° F
	Gliding, Hinged Inswing & Outswing Patio Doors, Patio Door Sidelights & Transoms	57%	0.29	0.25	59.6	2%	16%	71%	60° F
SmartSun Enhanced with HeatLock® Technology									
	Casement, Awning, Double-Hung, Picture, Transom & Specialty Windows	56%	0.27	0.24	56.9	2%	16%	54%	53° F
	Gliding, Hinged Inswing & Outswing Patio Doors, Patio Door Sidelights & Transoms	56%	0.27	0.24	56.9	2%	16%	54%	53° F

• "Low-E4" and "Low-E4 SmartSun" are Andersen trademarks for "Low-E" glass.
 • Based on NFRC testing/simulation conditions using Windows v7.4.6.0 and NFRC validated spectral data. 0°F outside temperature, 70°F inside temperature and a 15 mph wind.
 1) Visible Transmittance (VT) measures how much light comes through the glass. The higher the value, from 0 to 1, the more daylight the glass lets in. Visible Transmittance is measured over the 380 to 760 nanometer portion of the solar spectrum. 2) Shading Coefficient (SC) defines the amount of heat gain through the glass compared to a single light of clear 1/8" (3) glass. 3) Solar Heat Gain Coefficient (SHGC) defines the fraction of solar radiation admitted through the glass directly transmitted, as well as absorbed and subsequently released inward. The lower the value, the less heat is transmitted through the product. 4) Relative Heat Gain (RHG) is the amount of heat gain through a glazing incorporating U-Factor and Solar Heat Gain Coefficient. 5) Transmission Ultra-Violet Energy (Tuv). The transmission of short-wave energy in the 300-380 nanometer portion of the solar spectrum. The energy can cause fabric fading. 6) Transmission Damage Function (Tdw). The transmission of UV and visible light energy in the 300-600 nanometer portion of the solar spectrum. The value includes both the UV and visible light energy that can cause fabric fading. This rating has also been referred to as the Krochmann Damage Function. This rating better predicts fading potential than UV transmission alone. The lower the Damage Function rating, the less transmission of short-wave energy through the glass that can potentially cause fabric fading. Fabric type is also a key component of fading potential. 7) Percent relative humidity before condensation occurs at the center of glass, taken using center of glass temperature. 8) Inside glass surface temperatures are taken at the center of glass.
 • This data is accurate as of November 2022. Due to ongoing product changes, updated test results or new industry standards, this data may change over time. Contact your Andersen supplier for current performance information or upgrade options.
 • Contact your Andersen supplier for center of glass performance data on windows with patterned glass, tempered glass and products ordered with capillary breather tubes.

 Combination Designs,
 Product Performance
 & Installation

PRODUCT PERFORMANCE

Andersen® NFRC Certified Total Unit Performance – Dual-Pane Glass

For current performance information, please visit andersenwindows.com.

Andersen® Product	High-Performance Dual-Pane Glass Type	U-Factor ¹	SHGC ²	VT ³	
A-Series Casement Windows AND-N-86	Low-E4*	Without Grilles	0.27	0.27	0.45
		Simulated Divided Light Grilles	0.27	0.24	0.41
		Finelight™ Grilles	0.27	0.24	0.41
		Full Divided Light Grilles	0.28	0.24	0.41
	Low-E4 w/HeatLock*	Without Grilles	0.24	0.26	0.44
		Simulated Divided Light Grilles	0.24	0.24	0.40
		Finelight Grilles	0.24	0.24	0.40
		Full Divided Light Grilles	0.26	0.24	0.40
	Low-E4 Sun	Without Grilles	0.28	0.16	0.25
		Simulated Divided Light Grilles	0.28	0.15	0.23
		Finelight Grilles	0.28	0.15	0.23
	Low-E4 SmartSun™	Without Grilles	0.27	0.18	0.41
		Simulated Divided Light Grilles	0.27	0.16	0.37
		Finelight Grilles	0.27	0.16	0.37
		Energy Spacer Divided Light Grilles	0.27	0.16	0.37
	Low-E4 SmartSun w/HeatLock	Without Grilles	0.23	0.17	0.40
		Simulated Divided Light Grilles	0.23	0.16	0.36
		Finelight Grilles	0.23	0.16	0.36
		Energy Spacer Divided Light Grilles	0.23	0.16	0.36
	Low-E4 Full Divided Light Grilles	Without Grilles	0.25	0.16	0.36
Without Grilles		0.28	0.26	0.44	
Simulated Divided Light Grilles		0.28	0.23	0.39	
Finelight™ Grilles		0.28	0.23	0.39	
Low-E4 Full Divided Light Grilles	Without Grilles	0.28	0.23	0.39	
	Without Grilles	0.25	0.25	0.43	
	Simulated Divided Light Grilles	0.25	0.23	0.38	
	Finelight Grilles	0.25	0.23	0.38	
Low-E4 Full Divided Light Grilles	Without Grilles	0.26	0.23	0.38	
	Without Grilles	0.28	0.16	0.24	
	Simulated Divided Light Grilles	0.28	0.15	0.22	
	Finelight Grilles	0.28	0.15	0.22	
Low-E4 Full Divided Light Grilles	Without Grilles	0.29	0.15	0.22	
	Without Grilles	0.27	0.17	0.39	
	Simulated Divided Light Grilles	0.27	0.16	0.35	
	Finelight Grilles	0.27	0.16	0.35	
Low-E4 Full Divided Light Grilles	Without Grilles	0.27	0.16	0.35	
	Without Grilles	0.27	0.16	0.35	
	Energy Spacer Divided Light Grilles	0.27	0.16	0.35	
	Full Divided Light Grilles	0.28	0.16	0.35	
Low-E4 Full Divided Light Grilles	Without Grilles	0.24	0.17	0.39	
	Without Grilles	0.24	0.15	0.35	
	Simulated Divided Light Grilles	0.24	0.15	0.35	
	Finelight Grilles	0.24	0.15	0.35	
Low-E4 Full Divided Light Grilles	Without Grilles	0.24	0.15	0.35	
	Without Grilles	0.24	0.15	0.35	
	Energy Spacer Divided Light Grilles	0.24	0.15	0.35	
	Full Divided Light Grilles	0.25	0.15	0.35	
A-Series Awning Windows AND-N-87	Low-E4*	Without Grilles	0.29	0.30	0.52
		Simulated Divided Light Grilles	0.29	0.27	0.46
		Finelight™ Grilles	0.29	0.27	0.46
		Full Divided Light Grilles	0.30	0.27	0.46
	Low-E4 w/HeatLock*	Without Grilles	0.25	0.30	0.51
		Simulated Divided Light Grilles	0.25	0.27	0.45
		Finelight Grilles	0.25	0.27	0.45
		Full Divided Light Grilles	0.27	0.27	0.45
	Low-E4 Sun	Without Grilles	0.29	0.19	0.29
		Simulated Divided Light Grilles	0.29	0.17	0.26
		Finelight Grilles	0.29	0.17	0.26
	Low-E4 Sun	Without Grilles	0.31	0.17	0.26
Without Grilles		0.27	0.20	0.47	
Simulated Divided Light Grilles		0.27	0.18	0.41	
Low-E4 Sun	Without Grilles	0.27	0.18	0.41	
	Without Grilles	0.27	0.18	0.41	
	Energy Spacer Divided Light Grilles	0.27	0.18	0.41	
	Full Divided Light Grilles	0.30	0.18	0.41	
Low-E4 Sun	Without Grilles	0.25	0.20	0.46	
	Without Grilles	0.25	0.18	0.40	
	Simulated Divided Light Grilles	0.25	0.18	0.40	
	Finelight Grilles	0.25	0.18	0.40	
Low-E4 Sun	Without Grilles	0.25	0.18	0.40	
	Without Grilles	0.25	0.18	0.40	
	Energy Spacer Divided Light Grilles	0.25	0.18	0.40	
	Full Divided Light Grilles	0.27	0.18	0.40	

Andersen® Product	High-Performance Dual-Pane Glass Type	U-Factor ¹	SHGC ²	VT ³	
A-Series Picture Windows AND-N-88	Low-E4*	Without Grilles	0.27	0.31	0.54
		Simulated Divided Light Grilles	0.27	0.28	0.48
		Finelight™ Grilles	0.27	0.28	0.48
		Full Divided Light Grilles	0.28	0.28	0.48
	Low-E4 w/HeatLock*	Without Grilles	0.23	0.31	0.53
		Simulated Divided Light Grilles	0.23	0.28	0.47
		Finelight Grilles	0.23	0.28	0.47
		Full Divided Light Grilles	0.25	0.28	0.47
	Low-E4 Sun	Without Grilles	0.27	0.19	0.30
		Simulated Divided Light Grilles	0.27	0.17	0.27
		Finelight Grilles	0.27	0.17	0.27
	Low-E4 Sun	Without Grilles	0.29	0.17	0.27
		Without Grilles	0.26	0.21	0.49
		Simulated Divided Light Grilles	0.26	0.19	0.43
		Finelight Grilles	0.26	0.19	0.43
	Low-E4 Sun	Without Grilles	0.26	0.19	0.43
		Without Grilles	0.28	0.19	0.43
		Energy Spacer Divided Light Grilles	0.26	0.19	0.43
		Full Divided Light Grilles	0.28	0.19	0.43
	Low-E4 SmartSun™	Without Grilles	0.22	0.20	0.48
Simulated Divided Light Grilles		0.22	0.18	0.42	
Finelight Grilles		0.22	0.18	0.42	
Energy Spacer Divided Light Grilles		0.22	0.18	0.42	
Low-E4 SmartSun w/HeatLock	Without Grilles	0.22	0.18	0.42	
	Without Grilles	0.25	0.18	0.42	
	Full Divided Light Grilles	0.25	0.18	0.42	
	Without Grilles	0.28	0.27	0.46	
Low-E4 SmartSun w/HeatLock	Without Grilles	0.28	0.25	0.41	
	Simulated Divided Light Grilles	0.28	0.25	0.41	
	Finelight™ Grilles	0.28	0.25	0.41	
	Full Divided Light Grilles	0.28	0.25	0.41	
Low-E4 SmartSun w/HeatLock	Without Grilles	0.25	0.26	0.45	
	Without Grilles	0.25	0.24	0.40	
	Simulated Divided Light Grilles	0.25	0.24	0.40	
	Finelight Grilles	0.25	0.24	0.40	
Low-E4 SmartSun w/HeatLock	Without Grilles	0.26	0.24	0.40	
	Without Grilles	0.28	0.17	0.26	
	Simulated Divided Light Grilles	0.28	0.15	0.23	
	Finelight Grilles	0.28	0.15	0.23	
Low-E4 SmartSun w/HeatLock	Without Grilles	0.29	0.15	0.23	
	Without Grilles	0.27	0.18	0.41	
	Simulated Divided Light Grilles	0.27	0.16	0.37	
	Finelight Grilles	0.27	0.16	0.37	
Low-E4 SmartSun w/HeatLock	Without Grilles	0.27	0.16	0.37	
	Without Grilles	0.27	0.16	0.37	
	Energy Spacer Divided Light Grilles	0.27	0.16	0.37	
	Full Divided Light Grilles	0.28	0.16	0.37	
Low-E4 SmartSun w/HeatLock	Without Grilles	0.24	0.18	0.40	
	Without Grilles	0.24	0.16	0.36	
	Simulated Divided Light Grilles	0.24	0.16	0.36	
	Finelight Grilles	0.24	0.16	0.36	
Low-E4 SmartSun w/HeatLock	Without Grilles	0.24	0.16	0.36	
	Without Grilles	0.24	0.16	0.36	
	Energy Spacer Divided Light Grilles	0.24	0.16	0.36	
	Full Divided Light Grilles	0.25	0.16	0.36	

continued on next page

* "Low-E4", "Low-E4 SmartSun", "Low-E4 Sun" and "HeatLock" are Andersen trademarks for "Low-E" glass. 1) U-Factor defines the amount of heat loss through the total unit in BTU/hr-ft²-°F. The lower the value, the less heat is lost through the entire product. Window values represent non-tempered glass. Use of tempered glass can increase U-Factor ratings. See andersenwindows.com/nfrc for specific performance values. Door values represent tempered glass. 2) Solar Heat Gain Coefficient (SHGC) defines the fraction of solar radiation admitted through the glass directly transmitted, as well as absorbed and subsequently released inward. The lower the value, the less heat is transmitted through the product. 3) Visible Transmittance (VT) measures how much light comes through a product (glass and frame). The higher the value, from 0 to 1, the more daylight the product lets in over the product's total unit area. Visible Light Transmittance is measured over the 380 to 760 nanometer portion of the solar spectrum. *NFRC ratings are based on modeling by a third-party agency as validated by an independent test lab in compliance with NFRC program and procedural requirements. *This data is accurate as of November 2022. Due to ongoing product changes, updated test results, or new industry standards or requirements, this data may change over time. Ratings are for sizes specified by NFRC for testing and certification. Ratings may vary depending on use of tempered glass, different grille options, glass with capillary breather tubes for high altitudes, etc. * Values are for single units with given pane thickness and 3/4" (19 mm) grilles for windows and 1" (25 mm) grilles for door products.

Andersen® NFRC Certified Total Unit Performance – Dual-Pane Glass (continued)
 For current performance information, please visit andersenwindows.com.

Andersen® Product	High-Performance Dual-Pane Glass Type	U-Factor ¹	SHGC ²	VT ³	
A-Series Fixed Transom Windows AND-N-89	Low-E4*	Without Grilles	0.27	0.32	0.55
		Simulated Divided Light Grilles	0.27	0.29	0.49
		Finelight™ Grilles	0.27	0.29	0.49
		Full Divided Light Grilles	0.28	0.29	0.49
	Low-E4 w/HeatLock*	Without Grilles	0.23	0.31	0.54
		Simulated Divided Light Grilles	0.23	0.28	0.48
		Finelight Grilles	0.23	0.28	0.48
		Full Divided Light Grilles	0.25	0.28	0.48
	Low-E4 Sun	Without Grilles	0.27	0.20	0.31
		Simulated Divided Light Grilles	0.27	0.18	0.27
		Finelight Grilles	0.27	0.18	0.27
		Full Divided Light Grilles	0.29	0.18	0.27
	Low-E4 SmartSun™	Without Grilles	0.26	0.21	0.49
		Simulated Divided Light Grilles	0.26	0.19	0.44
		Finelight Grilles	0.26	0.19	0.44
		Energy Spacer Divided Light Grilles	0.26	0.19	0.44
		Full Divided Light Grilles	0.28	0.19	0.44
	Low-E4 SmartSun w/HeatLock	Without Grilles	0.22	0.21	0.48
		Simulated Divided Light Grilles	0.22	0.19	0.43
		Finelight Grilles	0.22	0.19	0.43
Energy Spacer Divided Light Grilles		0.22	0.19	0.43	
Full Divided Light Grilles		0.25	0.19	0.43	
A-Series Specialty Windows Direct-Set AND-N-126	Low-E4*	Without Grilles	0.29	0.35	0.61
		Simulated Divided Light Grilles	0.29	0.32	0.54
		Finelight™ Grilles	0.30	0.32	0.54
		Full Divided Light Grilles	0.30	0.32	0.54
	Low-E4 w/HeatLock*	Without Grilles	0.25	0.35	0.59
		Simulated Divided Light Grilles	0.25	0.31	0.53
		Finelight Grilles	0.26	0.31	0.53
		Full Divided Light Grilles	0.27	0.31	0.53
	Low-E4 Sun	Without Grilles	0.30	0.22	0.34
		Simulated Divided Light Grilles	0.30	0.20	0.30
		Finelight Grilles	0.31	0.20	0.30
		Full Divided Light Grilles	0.31	0.20	0.30
	Low-E4 SmartSun™	Without Grilles	0.28	0.23	0.55
		Simulated Divided Light Grilles	0.28	0.21	0.49
		Finelight Grilles	0.30	0.21	0.49
		Full Divided Light Grilles	0.30	0.21	0.49
	Low-E4 SmartSun w/HeatLock	Without Grilles	0.24	0.23	0.53
		Simulated Divided Light Grilles	0.24	0.21	0.48
		Finelight Grilles	0.25	0.21	0.48
		Full Divided Light Grilles	0.26	0.21	0.48
A-Series Specialty Windows Sash-Set AND-N-128	Low-E4*	Without Grilles	0.30	0.32	0.55
		Simulated Divided Light Grilles	0.30	0.29	0.49
		Finelight™ Grilles	0.31	0.29	0.49
		Full Divided Light Grilles	0.31	0.29	0.49
	Low-E4 w/HeatLock*	Without Grilles	0.26	0.31	0.53
		Simulated Divided Light Grilles	0.26	0.28	0.48
		Finelight Grilles	0.27	0.28	0.48
		Full Divided Light Grilles	0.28	0.28	0.48
	Low-E4 Sun	Without Grilles	0.30	0.20	0.30
		Simulated Divided Light Grilles	0.30	0.18	0.27
		Finelight Grilles	0.31	0.18	0.27
		Full Divided Light Grilles	0.31	0.18	0.27
	Low-E4 SmartSun™	Without Grilles	0.29	0.21	0.49
		Simulated Divided Light Grilles	0.29	0.19	0.44
		Finelight Grilles	0.30	0.19	0.44
		Full Divided Light Grilles	0.30	0.19	0.44
	Low-E4 SmartSun w/HeatLock	Without Grilles	0.25	0.21	0.48
		Simulated Divided Light Grilles	0.25	0.19	0.43
		Finelight Grilles	0.26	0.19	0.43
		Full Divided Light Grilles	0.27	0.19	0.43

Andersen® Product	High-Performance Dual-Pane Glass Type	U-Factor ¹	SHGC ²	VT ³	
A-Series Complementary Casement Windows AND-N-107	Low-E4*	Without Grilles	0.30	0.28	0.47
		Simulated Divided Light Grilles	0.30	0.25	0.42
		Finelight™ Grilles	0.30	0.25	0.42
		Full Divided Light Grilles	0.31	0.25	0.42
	Low-E4 w/HeatLock*	Without Grilles	0.27	0.27	0.46
		Simulated Divided Light Grilles	0.27	0.25	0.41
		Finelight Grilles	0.27	0.25	0.41
		Full Divided Light Grilles	0.28	0.25	0.41
	Low-E4 Sun	Without Grilles	0.30	0.17	0.26
		Simulated Divided Light Grilles	0.30	0.16	0.23
		Finelight Grilles	0.30	0.16	0.23
		Full Divided Light Grilles	0.31	0.16	0.23
	Low-E4 SmartSun™	Without Grilles	0.30	0.18	0.42
		Simulated Divided Light Grilles	0.30	0.17	0.38
		Finelight Grilles	0.30	0.17	0.38
		Full Divided Light Grilles	0.30	0.17	0.38
	Low-E4 SmartSun w/HeatLock	Without Grilles	0.26	0.18	0.41
		Simulated Divided Light Grilles	0.26	0.17	0.37
		Finelight Grilles	0.26	0.17	0.37
		Full Divided Light Grilles	0.28	0.17	0.37
A-Series Gliding Patio Doors Traditional Panels AND-N-99	Low-E4*	Without Grilles	0.30	0.27	0.45
		Blinds-Between-the-Glass*	0.35	0.24	0.40
		Simulated Divided Light Grilles	0.30	0.23	0.39
		Finelight™ Grilles	0.30	0.23	0.39
	Low-E4 w/HeatLock*	Without Grilles	0.27	0.26	0.44
		Simulated Divided Light Grilles	0.27	0.23	0.38
		Finelight Grilles	0.27	0.23	0.38
		Full Divided Light Grilles	0.29	0.23	0.38
	Low-E4 Sun	Without Grilles	0.30	0.16	0.25
		Simulated Divided Light Grilles	0.30	0.15	0.22
		Finelight Grilles	0.30	0.15	0.22
		Full Divided Light Grilles	0.32	0.15	0.22
	Low-E4 SmartSun™	Without Grilles	0.29	0.18	0.40
		Simulated Divided Light Grilles	0.29	0.16	0.35
		Finelight Grilles	0.29	0.16	0.35
		Energy Spacer Divided Light Grilles	0.29	0.16	0.35
	Low-E4 SmartSun w/HeatLock	Without Grilles	0.26	0.17	0.40
		Simulated Divided Light Grilles	0.26	0.15	0.34
		Finelight Grilles	0.26	0.15	0.34
		Energy Spacer Divided Light Grilles	0.26	0.15	0.34
Low-E4 SmartSun w/HeatLock	Without Grilles	0.26	0.15	0.34	
	Simulated Divided Light Grilles	0.26	0.15	0.34	
	Finelight Grilles	0.26	0.15	0.34	
	Energy Spacer Divided Light Grilles	0.26	0.15	0.34	

continued on next page

Combination Designs, Product Performance & Installation

* "Low-E4;" "Low-E4 SmartSun;" "Low-E4 Sun" and "HeatLock™" are Andersen trademarks for "Low-E" glass.
 1) U-Factor defines the amount of heat loss through the total unit in BTU/hr-ft²·°F. The lower the value, the less heat is lost through the entire product. Window values represent non-tempered glass. Use of tempered glass can increase U-Factor ratings. See andersenwindows.com/nfrc for specific performance values. Door values represent tempered glass. 2) Solar Heat Gain Coefficient (SHGC) defines the fraction of solar radiation admitted through the glass directly transmitted, as well as absorbed and subsequently released inward. The lower the value, the less heat is transmitted through the product. 3) Visible Transmittance (VT) measures how much light comes through a product (glass and frame). The higher the value, from 0 to 1, the more daylight the product lets in over the product's total unit area. Visible Light Transmittance is measured over the 380 to 760 nanometer portion of the solar spectrum.
 * NFRC ratings are based on modeling by a third-party agency as validated by an independent test lab in compliance with NFRC program and procedural requirements.
 * This data is accurate as of November 2022. Due to ongoing product changes, updated test results, or new industry standards or requirements, this data may change over time. Ratings are for sizes specified by NFRC for testing and certification. Ratings may vary depending on use of tempered glass, different grille options, glass with capillary breather tubes for high altitudes, etc.
 * Values are for single units with given pane thickness and 3/4" (19 mm) grilles for windows and 1" (25 mm) grilles for door products.
 * Available for select patio door sizes. Data based on blinds in full open position.

PRODUCT PERFORMANCE

Andersen® NFRC Certified Total Unit Performance – Dual-Pane Glass (continued)

For current performance information, please visit andersenwindows.com.

Andersen® Product	High-Performance Dual-Pane Glass Type	U-Factor ¹	SHGC ²	VT ³	
A-Series Gliding Patio Doors Contemporary Panels AND-N-212	Low-E4*	Without Grilles	0.29	0.28	0.48
		Blinds-Between-the-Glass*	0.35	0.26	0.43
		Simulated Divided Light Grilles	0.29	0.25	0.41
		Finelight™ Grilles	0.31	0.25	0.41
		Full Divided Light Grilles	0.31	0.25	0.41
	Low-E4 w/HeatLock®	Without Grilles	0.26	0.28	0.47
		Simulated Divided Light Grilles	0.26	0.24	0.40
		Finelight Grilles	0.27	0.24	0.40
		Full Divided Light Grilles	0.29	0.24	0.40
	Low-E4 Sun	Without Grilles	0.30	0.17	0.27
		Simulated Divided Light Grilles	0.30	0.15	0.23
		Finelight Grilles	0.31	0.15	0.23
		Full Divided Light Grilles	0.31	0.15	0.23
	Low-E4 SmartSun™	Without Grilles	0.29	0.19	0.43
		Simulated Divided Light Grilles	0.29	0.17	0.37
		Finelight Grilles	0.30	0.17	0.37
		Energy Spacer Divided Light Grilles	0.29	0.17	0.37
	Low-E4 SmartSun w/HeatLock	Without Grilles	0.25	0.18	0.42
		Simulated Divided Light Grilles	0.25	0.16	0.36
		Finelight Grilles	0.27	0.16	0.36
Energy Spacer Divided Light Grilles		0.25	0.16	0.36	
A-Series Hinged Inswing Patio Doors Traditional Panels AND-N-92	Low-E4*	Without Grilles	0.30	0.24	0.41
		Blinds-Between-the-Glass*	0.35	0.23	0.38
		Simulated Divided Light Grilles	0.30	0.21	0.35
		Finelight™ Grilles	0.30	0.21	0.35
		Full Divided Light Grilles	0.32	0.21	0.35
	Low-E4 w/HeatLock®	Without Grilles	0.27	0.24	0.40
		Simulated Divided Light Grilles	0.27	0.20	0.34
		Finelight Grilles	0.28	0.20	0.34
		Full Divided Light Grilles	0.30	0.20	0.34
	Low-E4 Sun	Without Grilles	0.31	0.15	0.23
		Simulated Divided Light Grilles	0.31	0.13	0.19
		Finelight Grilles	0.32	0.13	0.19
		Full Divided Light Grilles	0.32	0.13	0.19
	Low-E4 SmartSun™	Without Grilles	0.30	0.16	0.37
		Simulated Divided Light Grilles	0.30	0.14	0.31
		Finelight Grilles	0.31	0.14	0.31
		Energy Spacer Divided Light Grilles	0.30	0.14	0.31
	Low-E4 SmartSun w/HeatLock	Without Grilles	0.27	0.16	0.36
		Simulated Divided Light Grilles	0.27	0.14	0.31
		Finelight Grilles	0.28	0.14	0.31
Energy Spacer Divided Light Grilles		0.27	0.14	0.31	
A-Series Hinged Inswing Patio Doors Contemporary Panels AND-N-211	Low-E4*	Without Grilles	0.30	0.25	0.43
		Blinds-Between-the-Glass*	0.35	0.24	0.40
		Simulated Divided Light Grilles	0.30	0.22	0.37
		Finelight™ Grilles	0.31	0.22	0.37
		Full Divided Light Grilles	0.31	0.22	0.37
	Low-E4 w/HeatLock®	Without Grilles	0.27	0.25	0.42
		Simulated Divided Light Grilles	0.27	0.22	0.36
		Finelight Grilles	0.28	0.22	0.36
		Full Divided Light Grilles	0.29	0.22	0.36
	Low-E4 Sun	Without Grilles	0.30	0.16	0.24
		Simulated Divided Light Grilles	0.30	0.14	0.21
		Finelight Grilles	0.32	0.14	0.21
		Full Divided Light Grilles	0.32	0.14	0.21
	Low-E4 SmartSun™	Without Grilles	0.29	0.17	0.39
		Simulated Divided Light Grilles	0.29	0.15	0.33
		Finelight Grilles	0.31	0.15	0.33
		Energy Spacer Divided Light Grilles	0.29	0.15	0.33
	Low-E4 SmartSun w/HeatLock	Without Grilles	0.26	0.17	0.38
		Simulated Divided Light Grilles	0.26	0.15	0.33
		Finelight Grilles	0.28	0.15	0.33
Energy Spacer Divided Light Grilles		0.26	0.15	0.33	
Low-E4 SmartSun w/HeatLock	Without Grilles	0.26	0.15	0.33	
	Simulated Divided Light Grilles	0.26	0.15	0.33	
	Finelight Grilles	0.28	0.15	0.33	
	Energy Spacer Divided Light Grilles	0.26	0.15	0.33	

Andersen® Product	High-Performance Dual-Pane Glass Type	U-Factor ¹	SHGC ²	VT ³	
A-Series Hinged Outswing Patio Doors Traditional Panels AND-N-93	Low-E4*	Without Grilles	0.30	0.24	0.41
		Blinds-Between-the-Glass*	0.34	0.23	0.38
		Simulated Divided Light Grilles	0.30	0.21	0.35
		Finelight™ Grilles	0.31	0.21	0.35
		Full Divided Light Grilles	0.31	0.21	0.35
	Low-E4 w/HeatLock®	Without Grilles	0.27	0.24	0.40
		Simulated Divided Light Grilles	0.27	0.21	0.34
		Finelight Grilles	0.28	0.21	0.34
		Full Divided Light Grilles	0.29	0.21	0.34
	Low-E4 Sun	Without Grilles	0.30	0.15	0.23
		Simulated Divided Light Grilles	0.30	0.13	0.19
		Finelight Grilles	0.31	0.13	0.19
		Full Divided Light Grilles	0.32	0.13	0.19
	Low-E4 SmartSun™	Without Grilles	0.29	0.16	0.37
		Simulated Divided Light Grilles	0.29	0.14	0.31
		Finelight Grilles	0.31	0.14	0.31
		Energy Spacer Divided Light Grilles	0.29	0.14	0.31
	Low-E4 SmartSun w/HeatLock	Without Grilles	0.26	0.16	0.36
		Simulated Divided Light Grilles	0.26	0.14	0.31
		Finelight Grilles	0.28	0.14	0.31
Energy Spacer Divided Light Grilles		0.26	0.14	0.31	
A-Series Hinged Outswing Patio Doors Contemporary Panels AND-N-210	Low-E4*	Without Grilles	0.29	0.26	0.43
		Blinds-Between-the-Glass*	0.34	0.24	0.40
		Simulated Divided Light Grilles	0.29	0.23	0.37
		Finelight™ Grilles	0.31	0.23	0.37
		Full Divided Light Grilles	0.31	0.23	0.37
	Low-E4 w/HeatLock®	Without Grilles	0.26	0.25	0.42
		Simulated Divided Light Grilles	0.26	0.22	0.36
		Finelight Grilles	0.27	0.22	0.36
		Full Divided Light Grilles	0.29	0.22	0.36
	Low-E4 Sun	Without Grilles	0.30	0.16	0.24
		Simulated Divided Light Grilles	0.30	0.14	0.21
		Finelight Grilles	0.31	0.14	0.21
		Full Divided Light Grilles	0.31	0.14	0.21
	Low-E4 SmartSun™	Without Grilles	0.29	0.17	0.39
		Simulated Divided Light Grilles	0.29	0.15	0.33
		Finelight Grilles	0.30	0.15	0.33
		Energy Spacer Divided Light Grilles	0.29	0.15	0.33
	Low-E4 SmartSun w/HeatLock	Without Grilles	0.26	0.17	0.38
		Simulated Divided Light Grilles	0.26	0.15	0.33
		Finelight Grilles	0.27	0.15	0.33
Energy Spacer Divided Light Grilles		0.26	0.15	0.33	
Low-E4 SmartSun w/HeatLock	Without Grilles	0.26	0.15	0.33	
	Simulated Divided Light Grilles	0.26	0.15	0.33	
	Finelight Grilles	0.27	0.15	0.33	
	Energy Spacer Divided Light Grilles	0.26	0.15	0.33	

continued on next page

* "Low-E4"; "Low-E4 SmartSun"; "Low-E4 Sun" and "HeatLock" are Andersen trademarks for "Low-E" glass.
 1) U-Factor defines the amount of heat loss through the total unit in BTU/hr-ft²-°F. The lower the value, the less heat is lost through the entire product. Window values represent non-tempered glass. Use of tempered glass can increase U-Factor ratings. See andersenwindows.com/nfrc for specific performance values. Door values represent tempered glass. 2) Solar Heat Gain Coefficient (SHGC) defines the fraction of solar radiation admitted through the glass directly transmitted, as well as absorbed and subsequently released inward. The lower the value, the less heat is transmitted through the product. 3) Visible Transmittance (VT) measures how much light comes through a product (glass and frame). The higher the value, from 0 to 1, the more daylight the product lets in over the product's total unit area. Visible Light Transmittance is measured over the 380 to 760 nanometer portion of the solar spectrum.
 • NFRC ratings are based on modeling by a third-party agency as validated by an independent test lab in compliance with NFRC program and procedural requirements.
 • This data is accurate as of November 2022. Due to ongoing product changes, updated test results, or new industry standards or requirements, this data may change over time. Ratings are for sizes specified by NFRC for testing and certification. Ratings may vary depending on use of tempered glass, different grille options, glass with capillary breather tubes for high altitudes, etc.
 • Values are for single units with given pane thickness and 3/4" (19 mm) grilles for windows and 1" (25 mm) grilles for door products.
 • Available for select patio door sizes. Data based on blinds in full open position.

Andersen® NFRC Certified Total Unit Performance – Dual-Pane Glass (continued)
 For current performance information, please visit andersenwindows.com.

Andersen® Product	High-Performance Dual-Pane Glass Type	U-Factor ¹	SHGC ²	VT ³	
A-Series Patio Door Sidelight Transoms Direct-Set AND-N-96	Low-E4*	Without Grilles	0.28	0.34	0.58
		Simulated Divided Light Grilles	0.28	0.31	0.53
		Finelight™ Grilles	0.29	0.31	0.53
		Full Divided Light Grilles	0.29	0.31	0.53
	Low-E4 w/HeatLock®	Without Grilles	0.24	0.33	0.57
		Simulated Divided Light Grilles	0.24	0.30	0.51
		Finelight Grilles	0.24	0.30	0.51
		Full Divided Light Grilles	0.26	0.30	0.51
	Low-E4 Sun	Without Grilles	0.28	0.21	0.32
		Simulated Divided Light Grilles	0.28	0.19	0.29
		Finelight Grilles	0.29	0.19	0.29
		Full Divided Light Grilles	0.29	0.19	0.29
	Low-E4 SmartSun™	Without Grilles	0.27	0.22	0.52
		Simulated Divided Light Grilles	0.27	0.20	0.47
		Finelight Grilles	0.28	0.20	0.47
		Energy Spacer Divided Light Grilles	0.27	0.20	0.47
	Low-E4 SmartSun w/HeatLock	Without Grilles	0.23	0.22	0.51
		Simulated Divided Light Grilles	0.23	0.20	0.46
		Finelight Grilles	0.24	0.20	0.46
		Energy Spacer Divided Light Grilles	0.23	0.20	0.46
A-Series Patio Door Sidelight Transoms Sash-Set AND-N-95	Low-E4*	Without Grilles	0.29	0.26	0.43
		Simulated Divided Light Grilles	0.29	0.23	0.39
		Finelight™ Grilles	0.30	0.23	0.39
		Full Divided Light Grilles	0.30	0.23	0.39
	Low-E4 w/HeatLock®	Without Grilles	0.26	0.25	0.42
		Simulated Divided Light Grilles	0.26	0.23	0.38
		Finelight Grilles	0.27	0.23	0.38
		Full Divided Light Grilles	0.28	0.23	0.38
	Low-E4 Sun	Without Grilles	0.30	0.16	0.24
		Simulated Divided Light Grilles	0.30	0.15	0.21
		Finelight Grilles	0.30	0.15	0.21
		Full Divided Light Grilles	0.30	0.15	0.21
	Low-E4 SmartSun™	Without Grilles	0.29	0.17	0.39
		Simulated Divided Light Grilles	0.29	0.16	0.35
		Finelight Grilles	0.29	0.16	0.35
		Energy Spacer Divided Light Grilles	0.29	0.16	0.35
	Low-E4 SmartSun w/HeatLock	Without Grilles	0.26	0.17	0.38
		Simulated Divided Light Grilles	0.26	0.15	0.34
		Finelight Grilles	0.26	0.15	0.34
		Energy Spacer Divided Light Grilles	0.26	0.15	0.34
A-Series Patio Door Transoms Direct-Set AND-N-96	Low-E4*	Without Grilles	0.28	0.34	0.58
		Simulated Divided Light Grilles	0.28	0.31	0.53
		Finelight™ Grilles	0.29	0.31	0.53
		Full Divided Light Grilles	0.29	0.31	0.53
	Low-E4 w/HeatLock®	Without Grilles	0.24	0.33	0.57
		Simulated Divided Light Grilles	0.24	0.30	0.51
		Finelight Grilles	0.24	0.30	0.51
		Full Divided Light Grilles	0.26	0.30	0.51
	Low-E4 Sun	Without Grilles	0.28	0.21	0.32
		Simulated Divided Light Grilles	0.28	0.19	0.29
		Finelight Grilles	0.29	0.19	0.29
		Full Divided Light Grilles	0.29	0.19	0.29
	Low-E4 SmartSun™	Without Grilles	0.27	0.22	0.52
		Simulated Divided Light Grilles	0.27	0.20	0.47
		Finelight Grilles	0.28	0.20	0.47
		Energy Spacer Divided Light Grilles	0.27	0.20	0.47
	Low-E4 SmartSun w/HeatLock	Without Grilles	0.23	0.22	0.51
		Simulated Divided Light Grilles	0.23	0.20	0.46
		Finelight Grilles	0.24	0.20	0.46
		Energy Spacer Divided Light Grilles	0.23	0.20	0.46

Andersen® Product	High-Performance Dual-Pane Glass Type	U-Factor ¹	SHGC ²	VT ³	
A-Series Patio Door Transoms Sash-Set AND-N-95	Low-E4*	Without Grilles	0.30	0.25	0.41
		Simulated Divided Light Grilles	0.30	0.22	0.37
		Finelight™ Grilles	0.30	0.22	0.37
		Full Divided Light Grilles	0.30	0.22	0.37
	Low-E4 w/HeatLock®	Without Grilles	0.27	0.24	0.40
		Simulated Divided Light Grilles	0.27	0.22	0.36
		Finelight Grilles	0.27	0.22	0.36
		Full Divided Light Grilles	0.28	0.22	0.36
	Low-E4 Sun	Without Grilles	0.30	0.15	0.23
		Simulated Divided Light Grilles	0.30	0.14	0.20
		Finelight Grilles	0.31	0.14	0.20
		Full Divided Light Grilles	0.31	0.14	0.20
	Low-E4 SmartSun™	Without Grilles	0.29	0.16	0.37
		Simulated Divided Light Grilles	0.29	0.15	0.33
		Finelight Grilles	0.30	0.15	0.33
		Energy Spacer Divided Light Grilles	0.29	0.15	0.33
	Low-E4 SmartSun w/HeatLock	Without Grilles	0.26	0.16	0.36
		Simulated Divided Light Grilles	0.26	0.15	0.32
		Finelight Grilles	0.27	0.15	0.32
		Energy Spacer Divided Light Grilles	0.26	0.15	0.32
A-Series Patio Door Sidelights Traditional Panels AND-N-94	Low-E4*	Without Grilles	0.30	0.23	0.39
		Simulated Divided Light Grilles	0.30	0.21	0.34
		Finelight™ Grilles	0.31	0.21	0.34
		Full Divided Light Grilles	0.31	0.21	0.34
	Low-E4 w/HeatLock®	Without Grilles	0.27	0.23	0.38
		Simulated Divided Light Grilles	0.27	0.21	0.34
		Finelight Grilles	0.28	0.21	0.34
		Full Divided Light Grilles	0.29	0.21	0.34
	Low-E4 Sun	Without Grilles	0.30	0.15	0.22
		Simulated Divided Light Grilles	0.30	0.13	0.19
		Finelight Grilles	0.31	0.13	0.19
		Full Divided Light Grilles	0.31	0.13	0.19
	Low-E4 SmartSun™	Without Grilles	0.29	0.16	0.35
		Simulated Divided Light Grilles	0.29	0.14	0.31
		Finelight Grilles	0.30	0.14	0.31
		Energy Spacer Divided Light Grilles	0.29	0.14	0.31
	Low-E4 SmartSun w/HeatLock	Without Grilles	0.27	0.15	0.34
		Simulated Divided Light Grilles	0.27	0.14	0.30
		Finelight Grilles	0.27	0.14	0.30
		Energy Spacer Divided Light Grilles	0.27	0.14	0.30

continued on next page

* "Low-E4," "Low-E4 SmartSun," "Low-E4 Sun" and "HeatLock" are Andersen trademarks for "Low-E" glass.
 1) U-Factor defines the amount of heat loss through the total unit in BTU/hr-ft²-°F. The lower the value, the less heat is lost through the entire product. Window values represent non-tempered glass. Use of tempered glass can increase U-Factor ratings. See andersenwindows.com/nfrc for specific performance values. Door values represent tempered glass. 2) Solar Heat Gain Coefficient (SHGC) defines the fraction of solar radiation admitted through the glass directly transmitted, as well as absorbed and subsequently released inward. The lower the value, the less heat is transmitted through the product. 3) Visible Transmittance (VT) measures how much light comes through a product (glass and frame). The higher the value, from 0 to 1, the more daylight the product lets in over the product's total unit area. Visible Light Transmittance is measured over the 380 to 760 nanometer portion of the solar spectrum.
 • NFRC ratings are based on modeling by a third-party agency as validated by an independent test lab in compliance with NFRC program and procedural requirements.
 • This data is accurate as of November 2022. Due to ongoing product changes, updated test results, or new industry standards or requirements, this data may change over time. Ratings are for sizes specified by NFRC for testing and certification. Ratings may vary depending on use of tempered glass, different grille options, glass with capillary breather tubes for high altitudes, etc.
 • Values are for single units with given pane thickness and 3/4" (19 mm) grilles for windows and 1" (25 mm) grilles for door products.

Combination Designs,
Product Performance
& Installation

PRODUCT PERFORMANCE

Andersen® NFRC Certified Total Unit Performance – Dual-Pane Glass (continued)

For current performance information, please visit andersenwindows.com.

Andersen® Product	High-Performance Dual-Pane Glass Type	U-Factor ¹	SHGC ²	VT ³	
A-Series Patio Door Sidelights Contemporary Panels AND-N-213	Low-E4*	Without Grilles	0.30	0.22	0.36
		Simulated Divided Light Grilles	0.30	0.20	0.32
		Finelight™ Grilles	0.31	0.20	0.32
		Full Divided Light Grilles	0.31	0.20	0.32
	Low-E4 w/HeatLock®	Without Grilles	0.28	0.21	0.35
		Simulated Divided Light Grilles	0.28	0.19	0.31
		Finelight Grilles	0.28	0.19	0.31
		Full Divided Light Grilles	0.29	0.19	0.31
	Low-E4 Sun	Without Grilles	0.30	0.14	0.20
		Simulated Divided Light Grilles	0.30	0.12	0.18
		Finelight™ Grilles	0.31	0.12	0.18
		Full Divided Light Grilles	0.31	0.12	0.18
	Low-E4 SmartSun™	Without Grilles	0.30	0.15	0.32
		Simulated Divided Light Grilles	0.30	0.13	0.29
		Finelight Grilles	0.31	0.13	0.29
		Energy Spacer Divided Light Grilles	0.30	0.13	0.29
	Low-E4 SmartSun w/HeatLock	Without Grilles	0.27	0.14	0.32
		Simulated Divided Light Grilles	0.27	0.13	0.28
		Finelight Grilles	0.28	0.13	0.28
		Energy Spacer Divided Light Grilles	0.27	0.13	0.28
A-Series Complementary Hinged Inswing Patio Doors Springline® & Arch AND-N-127	Low-E4*	Without Grilles	0.33	0.24	0.41
		Simulated Divided Light Grilles	0.33	0.21	0.35
		Finelight™ Grilles	0.34	0.21	0.35
		Full Divided Light Grilles	0.34	0.21	0.35
	Low-E4 w/HeatLock®	Without Grilles	0.29	0.24	0.40
		Simulated Divided Light Grilles	0.29	0.21	0.34
		Finelight Grilles	0.31	0.21	0.34
		Full Divided Light Grilles	0.32	0.21	0.34
	Low-E4 Sun	Without Grilles	0.33	0.15	0.23
		Simulated Divided Light Grilles	0.33	0.13	0.20
		Finelight Grilles	0.34	0.13	0.20
		Full Divided Light Grilles	0.34	0.13	0.20
	Low-E4 SmartSun™	Without Grilles	0.32	0.16	0.37
		Simulated Divided Light Grilles	0.32	0.14	0.32
		Finelight Grilles	0.33	0.14	0.32
		Full Divided Light Grilles	0.34	0.14	0.32
	Low-E4 SmartSun w/HeatLock	Without Grilles	0.29	0.16	0.36
		Simulated Divided Light Grilles	0.29	0.14	0.31
		Finelight Grilles	0.30	0.14	0.31
		Full Divided Light Grilles	0.32	0.14	0.31
A-Series Complementary Hinged Outswing Patio Doors Springline & Arch AND-N-127	Low-E4*	Without Grilles	0.33	0.25	0.41
		Simulated Divided Light Grilles	0.33	0.22	0.35
		Finelight™ Grilles	0.35	0.22	0.35
		Full Divided Light Grilles	0.35	0.22	0.35
	Low-E4 w/HeatLock®	Without Grilles	0.30	0.24	0.40
		Simulated Divided Light Grilles	0.30	0.21	0.34
		Finelight Grilles	0.31	0.21	0.34
		Full Divided Light Grilles	0.33	0.21	0.34
	Low-E4 Sun	Without Grilles	0.33	0.16	0.23
		Simulated Divided Light Grilles	0.33	0.14	0.20
		Finelight Grilles	0.35	0.14	0.20
		Full Divided Light Grilles	0.35	0.14	0.20
	Low-E4 SmartSun™	Without Grilles	0.33	0.17	0.37
		Simulated Divided Light Grilles	0.33	0.15	0.32
		Finelight Grilles	0.34	0.15	0.32
		Full Divided Light Grilles	0.34	0.15	0.32
	Low-E4 SmartSun w/HeatLock	Without Grilles	0.30	0.16	0.36
		Simulated Divided Light Grilles	0.30	0.14	0.31
		Finelight Grilles	0.31	0.14	0.31
		Full Divided Light Grilles	0.32	0.14	0.31

Andersen® Product	High-Performance Dual-Pane Glass Type	U-Factor ¹	SHGC ²	VT ³	
A-Series Complementary Patio Door Sidelights Arch AND-N-131	Low-E4*	Without Grilles	0.32	0.23	0.39
		Simulated Divided Light Grilles	0.32	0.21	0.34
		Finelight™ Grilles	0.34	0.21	0.34
		Full Divided Light Grilles	0.33	0.21	0.34
	Low-E4 w/HeatLock®	Without Grilles	0.29	0.23	0.38
		Simulated Divided Light Grilles	0.29	0.21	0.34
		Finelight Grilles	0.30	0.21	0.34
		Full Divided Light Grilles	0.31	0.21	0.34
	Low-E4 Sun	Without Grilles	0.33	0.15	0.22
		Simulated Divided Light Grilles	0.33	0.13	0.19
		Finelight Grilles	0.34	0.13	0.19
		Full Divided Light Grilles	0.33	0.13	0.19
	Low-E4 SmartSun™	Without Grilles	0.32	0.16	0.35
		Simulated Divided Light Grilles	0.32	0.14	0.31
		Finelight Grilles	0.33	0.14	0.31
		Full Divided Light Grilles	0.33	0.14	0.31
	Low-E4 SmartSun w/HeatLock	Without Grilles	0.29	0.15	0.34
		Simulated Divided Light Grilles	0.29	0.14	0.30
		Finelight Grilles	0.30	0.14	0.30
		Full Divided Light Grilles	0.31	0.14	0.30

* "Low-E4™", "Low-E4 SmartSun™", "Low-E4 Sun" and "HeatLock™" are Andersen trademarks for "Low-E" glass.
 1) U-Factor defines the amount of heat loss through the total unit in BTU/hr-ft²-°F. The lower the value, the less heat is lost through the entire product. Window values represent non-tempered glass. Use of tempered glass can increase U-Factor ratings. See andersenwindows.com/nfrc for specific performance values. Door values represent tempered glass. 2) Solar Heat Gain Coefficient (SHGC) defines the fraction of solar radiation admitted through the glass directly transmitted, as well as absorbed and subsequently released inward. The lower the value, the less heat is transmitted through the product. 3) Visible Transmittance (VT) measures how much light comes through a product (glass and frame). The higher the value, from 0 to 1, the more daylight the product lets in over the product's total unit area. Visible Light Transmittance is measured over the 380 to 760 nanometer portion of the solar spectrum.
 • NFRC ratings are based on modeling by a third-party agency as validated by an independent test lab in compliance with NFRC program and procedural requirements.
 • This data is accurate as of November 2022. Due to ongoing product changes, updated test results, or new industry standards or requirements, this data may change over time. Ratings are for sizes specified by NFRC for testing and certification. Ratings may vary depending on use of tempered glass, different grille options, glass with capillary breather tubes for high altitudes, etc.
 • Values are for single units with given pane thickness and 3/4" (19 mm) grilles for windows and 1" (25 mm) grilles for door products.

Andersen® NFRC Certified Total Unit Performance – Triple-Pane Glass

 For current performance information, please visit andersenwindows.com.

Andersen® Product	High-Performance Triple-Pane Glass Type	U-Factor ¹	SHGC ²	VT ³	
A-Series Casement Windows AND-N-86	Low-E4*	Without Grilles	0.25	0.25	0.41
		Simulated Divided Light Grilles	0.25	0.23	0.37
		Finelight™ Grilles	0.25	0.23	0.37
		Full Divided Light Grilles	-	-	-
	Low-E4 Enhanced	Without Grilles	0.21	0.24	0.40
		Simulated Divided Light Grilles	0.21	0.22	0.36
		Finelight Grilles	0.22	0.22	0.36
		Full Divided Light Grilles	-	-	-
	Low-E4 Enhanced w/HeatLock®	Without Grilles	0.20	0.23	0.39
		Simulated Divided Light Grilles	0.20	0.21	0.35
		Finelight Grilles	0.20	0.21	0.35
		Full Divided Light Grilles	-	-	-
	Low-E4 SmartSun™	Without Grilles	0.24	0.17	0.37
		Simulated Divided Light Grilles	0.24	0.15	0.34
		Finelight Grilles	0.25	0.15	0.34
		Full Divided Light Grilles	-	-	-
	Low-E4 SmartSun Enhanced	Without Grilles	0.21	0.16	0.36
		Simulated Divided Light Grilles	0.21	0.15	0.32
		Finelight Grilles	0.21	0.15	0.32
		Full Divided Light Grilles	-	-	-
	Low-E4 SmartSun Enhanced w/HeatLock	Without Grilles	0.20	0.16	0.35
		Simulated Divided Light Grilles	0.20	0.14	0.32
		Finelight Grilles	0.20	0.14	0.32
		Full Divided Light Grilles	-	-	-
A-Series Awning Windows AND-N-87	Low-E4*	Without Grilles	0.25	0.24	0.40
		Simulated Divided Light Grilles	0.25	0.22	0.36
		Finelight™ Grilles	0.25	0.22	0.36
		Full Divided Light Grilles	-	-	-
	Low-E4 Enhanced	Without Grilles	0.22	0.23	0.38
		Simulated Divided Light Grilles	0.22	0.21	0.35
		Finelight Grilles	0.22	0.21	0.35
		Full Divided Light Grilles	-	-	-
	Low-E4 Enhanced w/HeatLock®	Without Grilles	0.20	0.22	0.38
		Simulated Divided Light Grilles	0.20	0.20	0.34
		Finelight Grilles	0.20	0.20	0.34
		Full Divided Light Grilles	-	-	-
	Low-E4 SmartSun™	Without Grilles	0.24	0.16	0.36
		Simulated Divided Light Grilles	0.24	0.15	0.32
		Finelight Grilles	0.25	0.15	0.32
		Full Divided Light Grilles	-	-	-
	Low-E4 SmartSun Enhanced	Without Grilles	0.22	0.16	0.35
		Simulated Divided Light Grilles	0.22	0.14	0.31
		Finelight Grilles	0.22	0.14	0.31
		Full Divided Light Grilles	-	-	-
	Low-E4 SmartSun Enhanced w/HeatLock	Without Grilles	0.20	0.15	0.34
		Simulated Divided Light Grilles	0.20	0.14	0.30
		Finelight Grilles	0.20	0.14	0.30
		Full Divided Light Grilles	-	-	-
A-Series Double-Hung Windows AND-N-91	Low-E4*	Without Grilles	0.26	0.28	0.47
		Simulated Divided Light Grilles	0.26	0.25	0.42
		Finelight™ Grilles	0.26	0.25	0.42
		Full Divided Light Grilles	-	-	-
	Low-E4 Enhanced	Without Grilles	0.22	0.27	0.46
		Simulated Divided Light Grilles	0.22	0.25	0.40
		Finelight Grilles	0.23	0.25	0.40
		Full Divided Light Grilles	-	-	-
	Low-E4 Enhanced w/HeatLock®	Without Grilles	0.20	0.26	0.44
		Simulated Divided Light Grilles	0.20	0.23	0.39
		Finelight Grilles	0.21	0.23	0.39
		Full Divided Light Grilles	-	-	-
	Low-E4 SmartSun™	Without Grilles	0.26	0.19	0.43
		Simulated Divided Light Grilles	0.26	0.17	0.38
		Finelight Grilles	0.26	0.17	0.38
		Full Divided Light Grilles	-	-	-
	Low-E4 SmartSun Enhanced	Without Grilles	0.22	0.18	0.41
		Simulated Divided Light Grilles	0.22	0.16	0.36
		Finelight Grilles	0.22	0.16	0.36
		Full Divided Light Grilles	-	-	-
	Low-E4 SmartSun Enhanced w/HeatLock	Without Grilles	0.20	0.18	0.40
		Simulated Divided Light Grilles	0.20	0.16	0.36
		Finelight Grilles	0.21	0.16	0.36
		Full Divided Light Grilles	-	-	-

Andersen® Product	High-Performance Triple-Pane Glass Type	U-Factor ¹	SHGC ²	VT ³	
A-Series Picture Windows AND-N-88	Low-E4*	Without Grilles	0.24	0.29	0.49
		Simulated Divided Light Grilles	0.24	0.26	0.43
		Finelight™ Grilles	0.24	0.26	0.43
		Full Divided Light Grilles	-	-	-
	Low-E4 Enhanced	Without Grilles	0.20	0.28	0.47
		Simulated Divided Light Grilles	0.20	0.25	0.42
		Finelight Grilles	0.20	0.25	0.42
		Full Divided Light Grilles	-	-	-
	Low-E4 Enhanced w/HeatLock®	Without Grilles	0.18	0.27	0.46
		Simulated Divided Light Grilles	0.18	0.24	0.41
		Finelight Grilles	0.18	0.24	0.41
		Full Divided Light Grilles	-	-	-
	Low-E4 SmartSun™	Without Grilles	0.23	0.20	0.44
		Simulated Divided Light Grilles	0.23	0.18	0.39
		Finelight Grilles	0.24	0.18	0.39
		Full Divided Light Grilles	-	-	-
	Low-E4 SmartSun Enhanced	Without Grilles	0.20	0.19	0.42
		Simulated Divided Light Grilles	0.20	0.17	0.38
		Finelight Grilles	0.20	0.17	0.38
		Full Divided Light Grilles	-	-	-
	Low-E4 SmartSun Enhanced w/HeatLock	Without Grilles	0.18	0.18	0.41
		Simulated Divided Light Grilles	0.18	0.17	0.37
		Finelight Grilles	0.18	0.17	0.37
		Full Divided Light Grilles	-	-	-
A-Series Venting Transom Windows AND-N-90	Low-E4*	Without Grilles	0.25	0.25	0.42
		Simulated Divided Light Grilles	0.25	0.23	0.38
		Finelight™ Grilles	0.25	0.23	0.38
		Full Divided Light Grilles	-	-	-
	Low-E4 Enhanced	Without Grilles	0.22	0.24	0.40
		Simulated Divided Light Grilles	0.22	0.22	0.36
		Finelight Grilles	0.22	0.22	0.36
		Full Divided Light Grilles	-	-	-
	Low-E4 Enhanced w/HeatLock®	Without Grilles	0.20	0.23	0.39
		Simulated Divided Light Grilles	0.20	0.21	0.36
		Finelight Grilles	0.20	0.21	0.36
		Full Divided Light Grilles	-	-	-
	Low-E4 SmartSun™	Without Grilles	0.25	0.17	0.38
		Simulated Divided Light Grilles	0.25	0.15	0.34
		Finelight Grilles	0.25	0.15	0.34
		Full Divided Light Grilles	-	-	-
	Low-E4 SmartSun Enhanced	Without Grilles	0.22	0.16	0.36
		Simulated Divided Light Grilles	0.22	0.15	0.33
		Finelight Grilles	0.22	0.15	0.33
		Full Divided Light Grilles	-	-	-
	Low-E4 SmartSun Enhanced w/HeatLock	Without Grilles	0.20	0.16	0.36
		Simulated Divided Light Grilles	0.20	0.14	0.32
		Finelight Grilles	0.20	0.14	0.32
		Full Divided Light Grilles	-	-	-

continued on next page

Combination Designs, Product Performance & Installation

* "Low-E4"; "Low-E4 SmartSun"; "Low-E4 Sun" and "HeatLock" are Andersen trademarks for "Low-E" glass.
 1) U-Factor defines the amount of heat loss through the total unit in BTU/hr-ft²·°F. The lower the value, the less heat is lost through the entire product. Window values represent non-tempered glass. Use of tempered glass can increase U-Factor ratings. See andersenwindows.com/nfrc for specific performance values. Door values represent tempered glass. 2) Solar Heat Gain Coefficient (SHGC) defines the fraction of solar radiation admitted through the glass directly transmitted, as well as absorbed and subsequently re-emitted inward. The lower the value, the less heat is transmitted through the product. 3) Visible Transmittance (VT) measures how much light comes through a product (glass and frame). The higher the value, from 0 to 1, the more daylight the product lets in over the product's total unit area. Visible Light Transmittance is measured over the 380 to 760 nanometer portion of the solar spectrum.
 • NFRC ratings are based on modeling by a third-party agency as validated by an independent test lab in compliance with NFRC program and procedural requirements.
 • This data is accurate as of November 2022. Due to ongoing product changes, updated test results, or new industry standards or requirements, this data may change over time. Ratings are for sizes specified by NFRC for testing and certification. Ratings may vary depending on use of tempered glass, different grille options, glass with capillary breather tubes for high altitudes, etc.
 • Values are for single units with given pane thickness and 3/8" (19 mm) grilles for windows and door products.

PRODUCT PERFORMANCE

Andersen® NFRC Certified Total Unit Performance – Triple-Pane Glass (continued)

For current performance information, please visit andersenwindows.com.

Andersen® Product	High-Performance Triple-Pane Glass Type	U-Factor ¹	SHGC ²	VT ³	
A-Series Fixed Transom Windows AND-N-89	Low-E4*	Without Grilles	0.24	0.29	0.50
		Simulated Divided Light Grilles	0.24	0.26	0.44
		Finelight™ Grilles	0.24	0.26	0.44
		Full Divided Light Grilles	-	-	-
	Low-E4 Enhanced	Without Grilles	0.20	0.28	0.48
		Simulated Divided Light Grilles	0.20	0.26	0.42
		Finelight Grilles	0.20	0.26	0.42
		Full Divided Light Grilles	-	-	-
	Low-E4 Enhanced w/HeatLock™	Without Grilles	0.18	0.27	0.47
		Simulated Divided Light Grilles	0.18	0.24	0.41
		Finelight Grilles	0.18	0.24	0.41
		Full Divided Light Grilles	-	-	-
	Low-E4 SmartSun™	Without Grilles	0.23	0.20	0.45
		Simulated Divided Light Grilles	0.23	0.18	0.40
		Finelight Grilles	0.24	0.18	0.40
		Full Divided Light Grilles	-	-	-
	Low-E4 SmartSun Enhanced	Without Grilles	0.20	0.19	0.43
		Simulated Divided Light Grilles	0.20	0.17	0.38
		Finelight Grilles	0.20	0.17	0.38
		Full Divided Light Grilles	-	-	-
	Low-E4 SmartSun Enhanced w/HeatLock	Without Grilles	0.18	0.18	0.42
		Simulated Divided Light Grilles	0.18	0.17	0.37
		Finelight Grilles	0.18	0.17	0.37
		Full Divided Light Grilles	-	-	-
A-Series Specialty Windows Direct-Set AND-N-126	Low-E4*	Without Grilles	0.22	0.33	0.56
		Simulated Divided Light Grilles	0.22	0.29	0.50
		Finelight™ Grilles	0.23	0.29	0.50
		Full Divided Light Grilles	0.23	0.29	0.50
	Low-E4 Enhanced	Without Grilles	0.18	0.32	0.53
		Simulated Divided Light Grilles	0.18	0.29	0.48
		Finelight Grilles	0.18	0.29	0.48
		Full Divided Light Grilles	0.18	0.29	0.48
	Low-E4 Enhanced w/HeatLock	Without Grilles	0.16	0.30	0.52
		Simulated Divided Light Grilles	0.16	0.28	0.47
		Finelight Grilles	0.16	0.28	0.47
		Full Divided Light Grilles	0.17	0.28	0.47
	Low-E4 SmartSun™	Without Grilles	0.22	0.22	0.50
		Simulated Divided Light Grilles	0.22	0.20	0.45
		Finelight Grilles	0.23	0.20	0.45
		Full Divided Light Grilles	0.23	0.20	0.45
	Low-E4 SmartSun Enhanced	Without Grilles	0.17	0.21	0.48
		Simulated Divided Light Grilles	0.17	0.19	0.43
		Finelight Grilles	0.17	0.19	0.43
		Full Divided Light Grilles	0.18	0.19	0.43
	Low-E4 SmartSun Enhanced w/HeatLock	Without Grilles	0.16	0.20	0.47
		Simulated Divided Light Grilles	0.16	0.18	0.42
		Finelight Grilles	0.16	0.18	0.42
		Full Divided Light Grilles	0.17	0.18	0.42
A-Series Specialty Windows Sash-Set AND-N-128	Low-E4*	Without Grilles	0.23	0.29	0.50
		Simulated Divided Light Grilles	0.23	0.27	0.44
		Finelight™ Grilles	0.24	0.27	0.44
		Full Divided Light Grilles	0.24	0.27	0.44
	Low-E4 Enhanced	Without Grilles	0.19	0.29	0.48
		Simulated Divided Light Grilles	0.19	0.26	0.43
		Finelight Grilles	0.19	0.26	0.43
		Full Divided Light Grilles	0.19	0.26	0.43
	Low-E4 Enhanced w/HeatLock	Without Grilles	0.17	0.28	0.47
		Simulated Divided Light Grilles	0.17	0.25	0.42
		Finelight Grilles	0.18	0.25	0.42
		Full Divided Light Grilles	0.18	0.25	0.42
	Low-E4 SmartSun™	Without Grilles	0.23	0.19	0.45
		Simulated Divided Light Grilles	0.23	0.18	0.40
		Finelight Grilles	0.23	0.18	0.40
		Full Divided Light Grilles	0.23	0.18	0.40
	Low-E4 SmartSun Enhanced	Without Grilles	0.18	0.19	0.43
		Simulated Divided Light Grilles	0.18	0.17	0.39
		Finelight Grilles	0.19	0.17	0.39
		Full Divided Light Grilles	0.19	0.17	0.39
	Low-E4 SmartSun Enhanced w/HeatLock	Without Grilles	0.17	0.18	0.42
		Simulated Divided Light Grilles	0.17	0.17	0.38
		Finelight Grilles	0.17	0.17	0.38
		Full Divided Light Grilles	0.18	0.17	0.38

Andersen® Product	High-Performance Triple-Pane Glass Type	U-Factor ¹	SHGC ²	VT ³	
A-Series Gliding Patio Doors Traditional Panels AND-N-99	Low-E4*	Without Grilles	0.28	0.25	0.41
		Simulated Divided Light Grilles	0.28	0.22	0.35
		Finelight™ Grilles	0.28	0.22	0.35
		Full Divided Light Grilles	-	-	-
	Low-E4 Enhanced	Without Grilles	0.25	0.24	0.40
		Simulated Divided Light Grilles	0.25	0.21	0.34
		Finelight Grilles	0.25	0.21	0.34
		Full Divided Light Grilles	-	-	-
	Low-E4 Enhanced w/HeatLock™	Without Grilles	0.23	0.23	0.39
		Simulated Divided Light Grilles	0.23	0.20	0.33
		Finelight Grilles	0.23	0.20	0.33
		Full Divided Light Grilles	-	-	-
	Low-E4 SmartSun™	Without Grilles	0.27	0.17	0.37
		Simulated Divided Light Grilles	0.27	0.15	0.32
		Finelight Grilles	0.28	0.15	0.32
		Full Divided Light Grilles	-	-	-
	Low-E4 SmartSun Enhanced	Without Grilles	0.24	0.16	0.36
		Simulated Divided Light Grilles	0.24	0.14	0.31
		Finelight Grilles	0.25	0.14	0.31
		Full Divided Light Grilles	-	-	-
	Low-E4 SmartSun Enhanced w/HeatLock	Without Grilles	0.23	0.16	0.35
		Simulated Divided Light Grilles	0.23	0.14	0.30
		Finelight Grilles	0.23	0.14	0.30
		Full Divided Light Grilles	-	-	-
A-Series Gliding Patio Doors Contemporary Panels AND-N-212	Low-E4*	Without Grilles	0.27	0.26	0.44
		Simulated Divided Light Grilles	0.27	0.23	0.38
		Finelight™ Grilles	0.28	0.23	0.38
		Full Divided Light Grilles	-	-	-
	Low-E4 Enhanced	Without Grilles	0.24	0.26	0.42
		Simulated Divided Light Grilles	0.24	0.22	0.36
		Finelight Grilles	0.24	0.22	0.36
		Full Divided Light Grilles	-	-	-
	Low-E4 Enhanced w/HeatLock	Without Grilles	0.22	0.24	0.41
		Simulated Divided Light Grilles	0.22	0.22	0.36
		Finelight Grilles	0.22	0.22	0.36
		Full Divided Light Grilles	-	-	-
	Low-E4 SmartSun™	Without Grilles	0.27	0.18	0.39
		Simulated Divided Light Grilles	0.27	0.16	0.34
		Finelight Grilles	0.27	0.16	0.34
		Full Divided Light Grilles	-	-	-
	Low-E4 SmartSun Enhanced	Without Grilles	0.24	0.17	0.38
		Simulated Divided Light Grilles	0.24	0.15	0.33
		Finelight Grilles	0.24	0.15	0.33
		Full Divided Light Grilles	-	-	-
	Low-E4 SmartSun Enhanced w/HeatLock	Without Grilles	0.22	0.16	0.37
		Simulated Divided Light Grilles	0.22	0.15	0.32
		Finelight Grilles	0.22	0.15	0.32
		Full Divided Light Grilles	-	-	-

continued on next page

- "Low-E4"; "Low-E4 SmartSun"; "Low-E4 Sun" and "HeatLock" are Andersen trademarks for "Low-E" glass.
- 1) U-Factor defines the amount of heat loss through the total unit in BTU/hr-ft²-°F. The lower the value, the less heat is lost through the entire product. Window values represent non-tempered glass. Use of tempered glass can increase U-Factor ratings. See andersenwindows.com/nfrc for specific performance values. Door values represent tempered glass.
- 2) Solar Heat Gain Coefficient (SHGC) defines the fraction of solar radiation admitted through the glass directly transmitted, as well as absorbed and subsequently released inward. The lower the value, the less heat is transmitted through the product.
- 3) Visible Transmittance (VT) measures how much light comes through a product (glass and frame). The higher the value, from 0 to 1, the more daylight the product lets in over the product's total unit area. Visible Light Transmittance is measured over the 380 to 760 nanometer portion of the solar spectrum.
- NFRC ratings are based on modeling by a third-party agency as validated by an independent test lab in compliance with NFRC program and procedural requirements.
- This data is accurate as of November 2022. Due to ongoing product changes, updated test results, or new industry standards or requirements, this data may change over time. Ratings are for sizes specified by NFRC for testing and certification. Ratings may vary depending on use of tempered glass, different grille options, glass with capillary breather tubes for high altitudes, etc.
- Values are for single units with given pane thickness and 3/4" (19 mm) grilles for windows and door products.

Andersen® NFRC Certified Total Unit Performance – Triple-Pane Glass (continued)
 For current performance information, please visit andersenwindows.com.

Andersen® Product	High-Performance Triple-Pane Glass Type	U-Factor ¹	SHGC ²	VT ³	
A-Series Hinged Inswing Patio Doors Traditional Panels AND-N-92	Low-E4*	Without Grilles	0.28	0.22	0.37
		Simulated Divided Light Grilles	0.28	0.19	0.32
		Finelight™ Grilles	0.28	0.19	0.32
		Full Divided Light Grilles	-	-	-
	Low-E4 Enhanced	Without Grilles	0.25	0.22	0.36
		Simulated Divided Light Grilles	0.25	0.19	0.31
		Finelight Grilles	0.26	0.19	0.31
		Full Divided Light Grilles	-	-	-
	Low-E4 Enhanced w/HeatLock®	Without Grilles	0.24	0.21	0.35
		Simulated Divided Light Grilles	0.24	0.18	0.30
		Finelight Grilles	0.24	0.18	0.30
		Full Divided Light Grilles	-	-	-
	Low-E4 SmartSun™	Without Grilles	0.28	0.15	0.34
		Simulated Divided Light Grilles	0.28	0.13	0.29
		Finelight Grilles	0.29	0.13	0.29
		Full Divided Light Grilles	-	-	-
	Low-E4 SmartSun Enhanced	Without Grilles	0.25	0.15	0.32
		Simulated Divided Light Grilles	0.25	0.13	0.28
		Finelight Grilles	0.26	0.13	0.28
		Full Divided Light Grilles	-	-	-
	Low-E4 SmartSun Enhanced w/HeatLock	Without Grilles	0.24	0.14	0.32
		Simulated Divided Light Grilles	0.24	0.12	0.27
		Finelight Grilles	0.24	0.12	0.27
		Full Divided Light Grilles	-	-	-
A-Series Hinged Inswing Patio Doors Contemporary Panels AND-N-211	Low-E4*	Without Grilles	0.28	0.24	0.40
		Simulated Divided Light Grilles	0.28	0.21	0.34
		Finelight™ Grilles	0.28	0.21	0.34
		Full Divided Light Grilles	-	-	-
	Low-E4 Enhanced	Without Grilles	0.25	0.23	0.38
		Simulated Divided Light Grilles	0.25	0.20	0.33
		Finelight Grilles	0.25	0.20	0.33
		Full Divided Light Grilles	-	-	-
	Low-E4 Enhanced w/HeatLock®	Without Grilles	0.23	0.22	0.37
		Simulated Divided Light Grilles	0.23	0.19	0.32
		Finelight Grilles	0.24	0.19	0.32
		Full Divided Light Grilles	-	-	-
	Low-E4 SmartSun™	Without Grilles	0.27	0.16	0.36
		Simulated Divided Light Grilles	0.27	0.14	0.31
		Finelight Grilles	0.29	0.14	0.31
		Full Divided Light Grilles	-	-	-
	Low-E4 SmartSun Enhanced	Without Grilles	0.25	0.15	0.34
		Simulated Divided Light Grilles	0.25	0.14	0.29
		Finelight Grilles	0.25	0.14	0.29
		Full Divided Light Grilles	-	-	-
	Low-E4 SmartSun Enhanced w/HeatLock	Without Grilles	0.23	0.15	0.33
		Simulated Divided Light Grilles	0.23	0.13	0.29
		Finelight Grilles	0.23	0.13	0.29
		Full Divided Light Grilles	-	-	-
A-Series Hinged Outswing Patio Doors Traditional Panels AND-N-93	Low-E4*	Without Grilles	0.28	0.23	0.37
		Simulated Divided Light Grilles	0.28	0.20	0.32
		Finelight™ Grilles	0.28	0.20	0.32
		Full Divided Light Grilles	-	-	-
	Low-E4 Enhanced	Without Grilles	0.25	0.22	0.36
		Simulated Divided Light Grilles	0.25	0.19	0.31
		Finelight Grilles	0.25	0.19	0.31
		Full Divided Light Grilles	-	-	-
	Low-E4 Enhanced w/HeatLock®	Without Grilles	0.24	0.21	0.35
		Simulated Divided Light Grilles	0.24	0.19	0.30
		Finelight Grilles	0.24	0.19	0.30
		Full Divided Light Grilles	-	-	-
	Low-E4 SmartSun™	Without Grilles	0.28	0.15	0.34
		Simulated Divided Light Grilles	0.28	0.14	0.29
		Finelight Grilles	0.28	0.14	0.29
		Full Divided Light Grilles	-	-	-
	Low-E4 SmartSun Enhanced	Without Grilles	0.25	0.15	0.32
		Simulated Divided Light Grilles	0.25	0.13	0.28
		Finelight Grilles	0.25	0.13	0.28
		Full Divided Light Grilles	-	-	-
	Low-E4 SmartSun Enhanced w/HeatLock	Without Grilles	0.23	0.14	0.32
		Simulated Divided Light Grilles	0.23	0.13	0.27
		Finelight Grilles	0.24	0.13	0.27
		Full Divided Light Grilles	-	-	-

Andersen® Product	High-Performance Triple-Pane Glass Type	U-Factor ¹	SHGC ²	VT ³	
A-Series Hinged Outswing Patio Doors Contemporary Panels AND-N-210	Low-E4*	Without Grilles	0.27	0.24	0.40
		Simulated Divided Light Grilles	0.27	0.21	0.34
		Finelight™ Grilles	0.28	0.21	0.34
		Full Divided Light Grilles	-	-	-
	Low-E4 Enhanced	Without Grilles	0.24	0.23	0.38
		Simulated Divided Light Grilles	0.24	0.20	0.33
		Finelight Grilles	0.25	0.20	0.33
		Full Divided Light Grilles	-	-	-
	Low-E4 Enhanced w/HeatLock®	Without Grilles	0.23	0.22	0.37
		Simulated Divided Light Grilles	0.23	0.20	0.32
		Finelight Grilles	0.23	0.20	0.32
		Full Divided Light Grilles	-	-	-
	Low-E4 SmartSun™	Without Grilles	0.27	0.16	0.36
		Simulated Divided Light Grilles	0.27	0.14	0.31
		Finelight Grilles	0.28	0.14	0.31
		Full Divided Light Grilles	-	-	-
	Low-E4 SmartSun Enhanced	Without Grilles	0.24	0.16	0.34
		Simulated Divided Light Grilles	0.24	0.14	0.29
		Finelight Grilles	0.24	0.14	0.29
		Full Divided Light Grilles	-	-	-
	Low-E4 SmartSun Enhanced w/HeatLock	Without Grilles	0.23	0.15	0.33
		Simulated Divided Light Grilles	0.23	0.13	0.29
		Finelight Grilles	0.23	0.13	0.29
		Full Divided Light Grilles	-	-	-
A-Series Patio Door Sidelight Transoms Direct-Set AND-N-96	Low-E4*	Without Grilles	0.25	0.31	0.53
		Simulated Divided Light Grilles	0.25	0.29	0.48
		Finelight™ Grilles	0.25	0.29	0.48
		Full Divided Light Grilles	-	-	-
	Low-E4 Enhanced	Without Grilles	0.21	0.30	0.51
		Simulated Divided Light Grilles	0.21	0.28	0.46
		Finelight Grilles	0.21	0.28	0.46
		Full Divided Light Grilles	-	-	-
	Low-E4 Enhanced w/HeatLock®	Without Grilles	0.19	0.29	0.50
		Simulated Divided Light Grilles	0.19	0.27	0.45
		Finelight Grilles	0.19	0.27	0.45
		Full Divided Light Grilles	-	-	-
	Low-E4 SmartSun™	Without Grilles	0.24	0.21	0.48
		Simulated Divided Light Grilles	0.24	0.19	0.43
		Finelight Grilles	0.25	0.19	0.43
		Full Divided Light Grilles	-	-	-
	Low-E4 SmartSun Enhanced	Without Grilles	0.20	0.20	0.46
		Simulated Divided Light Grilles	0.20	0.19	0.42
		Finelight Grilles	0.20	0.19	0.42
		Full Divided Light Grilles	-	-	-
	Low-E4 SmartSun Enhanced w/HeatLock	Without Grilles	0.19	0.20	0.45
		Simulated Divided Light Grilles	0.19	0.18	0.41
		Finelight Grilles	0.19	0.18	0.41
		Full Divided Light Grilles	-	-	-

continued on next page

Combination Designs, Product Performance & Installation

*"Low-E4"; "Low-E4 SmartSun"; "Low-E4 Sun" and "HeatLock" are Andersen trademarks for "Low-E" glass.
 1) U-Factor defines the amount of heat loss through the total unit in BTU/hr-ft²-°F. The lower the value, the less heat is lost through the entire product. Window values represent non-tempered glass. Use of tempered glass can increase U-Factor ratings. See andersenwindows.com/nfrc for specific performance values. Door values represent tempered glass. 2) Solar Heat Gain Coefficient (SHGC) defines the fraction of solar radiation admitted through the glass directly transmitted, as well as absorbed and subsequently released inward. The lower the value, the less heat is transmitted through the product. 3) Visible Transmittance (VT) measures how much light comes through a product (glass and frame). The higher the value, from 0 to 1, the more daylight the product lets in over the product's total unit area. Visible Light Transmittance is measured over the 380 to 760 nanometer portion of the solar spectrum.
 • NFRC ratings are based on modeling by a third-party agency as validated by an independent test lab in compliance with NFRC program and procedural requirements.
 • This data is accurate as of November 2022. Due to ongoing product changes, updated test results, or new industry standards or requirements, this data may change over time. Ratings are for sizes specified by NFRC for testing and certification. Ratings may vary depending on use of tempered glass, different grille options, glass with capillary breather tubes for high altitudes, etc.
 • Values are for single units with given pane thickness and 3/4" (19 mm) grilles for windows and door products.

PRODUCT PERFORMANCE

Andersen® NFRC Certified Total Unit Performance – Triple-Pane Glass (continued)
For current performance information, please visit andersenwindows.com.

Andersen® Product	High-Performance Triple-Pane Glass Type	U-Factor ¹	SHGC ²	VT ³	
A-Series Patio Door Sidelight Transoms Sash-Set AND-N-95	Low-E4*	Without Grilles	0.27	0.24	0.40
		Simulated Divided Light Grilles	0.27	0.22	0.35
		Finelight™ Grilles	0.27	0.22	0.35
		Full Divided Light Grilles	-	-	-
	Low-E4 Enhanced	Without Grilles	0.24	0.23	0.38
		Simulated Divided Light Grilles	0.24	0.21	0.34
		Finelight™ Grilles	0.24	0.21	0.34
		Full Divided Light Grilles	-	-	-
	Low-E4 Enhanced w/HeatLock®	Without Grilles	0.22	0.22	0.37
		Simulated Divided Light Grilles	0.22	0.20	0.33
		Finelight™ Grilles	0.22	0.20	0.33
		Full Divided Light Grilles	-	-	-
	Low-E4 SmartSun™	Without Grilles	0.26	0.16	0.36
		Simulated Divided Light Grilles	0.26	0.15	0.32
		Finelight™ Grilles	0.27	0.15	0.32
		Full Divided Light Grilles	-	-	-
	Low-E4 SmartSun Enhanced	Without Grilles	0.24	0.16	0.34
		Simulated Divided Light Grilles	0.24	0.14	0.31
		Finelight™ Grilles	0.24	0.14	0.31
		Full Divided Light Grilles	-	-	-
	Low-E4 SmartSun Enhanced w/HeatLock	Without Grilles	0.22	0.15	0.33
		Simulated Divided Light Grilles	0.22	0.14	0.30
		Finelight™ Grilles	0.22	0.14	0.30
		Full Divided Light Grilles	-	-	-
A-Series Patio Door Transoms Direct-Set AND-N-96	Low-E4*	Without Grilles	0.25	0.31	0.53
		Simulated Divided Light Grilles	0.25	0.29	0.48
		Finelight™ Grilles	0.25	0.29	0.48
		Full Divided Light Grilles	-	-	-
	Low-E4 Enhanced	Without Grilles	0.21	0.30	0.51
		Simulated Divided Light Grilles	0.21	0.28	0.46
		Finelight™ Grilles	0.21	0.28	0.46
		Full Divided Light Grilles	-	-	-
	Low-E4 Enhanced w/HeatLock	Without Grilles	0.19	0.29	0.50
		Simulated Divided Light Grilles	0.19	0.27	0.45
		Finelight™ Grilles	0.19	0.27	0.45
		Full Divided Light Grilles	-	-	-
	Low-E4 SmartSun™	Without Grilles	0.24	0.21	0.48
		Simulated Divided Light Grilles	0.24	0.19	0.43
		Finelight™ Grilles	0.25	0.19	0.43
		Full Divided Light Grilles	-	-	-
	Low-E4 SmartSun Enhanced	Without Grilles	0.20	0.20	0.46
		Simulated Divided Light Grilles	0.20	0.19	0.42
		Finelight™ Grilles	0.20	0.19	0.42
		Full Divided Light Grilles	-	-	-
	Low-E4 SmartSun Enhanced w/HeatLock	Without Grilles	0.19	0.20	0.45
		Simulated Divided Light Grilles	0.19	0.18	0.41
		Finelight™ Grilles	0.19	0.18	0.41
		Full Divided Light Grilles	-	-	-
A-Series Patio Door Transoms Sash-Set AND-N-95	Low-E4*	Without Grilles	0.27	0.23	0.38
		Simulated Divided Light Grilles	0.27	0.21	0.33
		Finelight™ Grilles	0.27	0.21	0.33
		Full Divided Light Grilles	-	-	-
	Low-E4 Enhanced	Without Grilles	0.24	0.22	0.36
		Simulated Divided Light Grilles	0.24	0.20	0.32
		Finelight™ Grilles	0.24	0.20	0.32
		Full Divided Light Grilles	-	-	-
	Low-E4 Enhanced w/HeatLock®	Without Grilles	0.23	0.21	0.35
		Simulated Divided Light Grilles	0.23	0.19	0.31
		Finelight™ Grilles	0.23	0.19	0.31
		Full Divided Light Grilles	-	-	-
	Low-E4 SmartSun™	Without Grilles	0.27	0.15	0.34
		Simulated Divided Light Grilles	0.27	0.14	0.30
		Finelight™ Grilles	0.27	0.14	0.30
		Full Divided Light Grilles	-	-	-
	Low-E4 SmartSun Enhanced	Without Grilles	0.24	0.15	0.33
		Simulated Divided Light Grilles	0.24	0.14	0.29
		Finelight™ Grilles	0.24	0.14	0.29
		Full Divided Light Grilles	-	-	-
	Low-E4 SmartSun Enhanced w/HeatLock	Without Grilles	0.23	0.15	0.32
		Simulated Divided Light Grilles	0.23	0.13	0.28
		Finelight™ Grilles	0.23	0.13	0.28
		Full Divided Light Grilles	-	-	-

Andersen® Product	High-Performance Triple-Pane Glass Type	U-Factor ¹	SHGC ²	VT ³	
A-Series Patio Door Sidelights Traditional Panels AND-N-94	Low-E4*	Without Grilles	0.28	0.22	0.35
		Simulated Divided Light Grilles	0.28	0.20	0.31
		Finelight™ Grilles	0.28	0.20	0.31
		Full Divided Light Grilles	-	-	-
	Low-E4 Enhanced	Without Grilles	0.25	0.21	0.34
		Simulated Divided Light Grilles	0.25	0.19	0.30
		Finelight™ Grilles	0.25	0.19	0.30
		Full Divided Light Grilles	-	-	-
	Low-E4 Enhanced w/HeatLock®	Without Grilles	0.24	0.20	0.33
		Simulated Divided Light Grilles	0.24	0.18	0.30
		Finelight™ Grilles	0.24	0.18	0.30
		Full Divided Light Grilles	-	-	-
	Low-E4 SmartSun™	Without Grilles	0.27	0.15	0.32
		Simulated Divided Light Grilles	0.27	0.13	0.28
		Finelight™ Grilles	0.28	0.13	0.28
		Full Divided Light Grilles	-	-	-
	Low-E4 SmartSun Enhanced	Without Grilles	0.25	0.14	0.31
		Simulated Divided Light Grilles	0.25	0.13	0.27
		Finelight™ Grilles	0.25	0.13	0.27
		Full Divided Light Grilles	-	-	-
	Low-E4 SmartSun Enhanced w/HeatLock	Without Grilles	0.23	0.14	0.30
		Simulated Divided Light Grilles	0.23	0.13	0.27
		Finelight™ Grilles	0.24	0.13	0.27
		Full Divided Light Grilles	-	-	-
A-Series Patio Door Sidelights Contemporary Panels AND-N-213	Low-E4*	Without Grilles	0.28	0.20	0.33
		Simulated Divided Light Grilles	0.28	0.18	0.29
		Finelight™ Grilles	0.29	0.18	0.29
		Full Divided Light Grilles	-	-	-
	Low-E4 Enhanced	Without Grilles	0.26	0.20	0.32
		Simulated Divided Light Grilles	0.26	0.18	0.28
		Finelight™ Grilles	0.26	0.18	0.28
		Full Divided Light Grilles	-	-	-
	Low-E4 Enhanced w/HeatLock	Without Grilles	0.24	0.19	0.31
		Simulated Divided Light Grilles	0.24	0.17	0.27
		Finelight™ Grilles	0.25	0.17	0.27
		Full Divided Light Grilles	-	-	-
	Low-E4 SmartSun™	Without Grilles	0.28	0.14	0.30
		Simulated Divided Light Grilles	0.28	0.13	0.26
		Finelight™ Grilles	0.28	0.13	0.26
		Full Divided Light Grilles	-	-	-
	Low-E4 SmartSun Enhanced	Without Grilles	0.26	0.13	0.29
		Simulated Divided Light Grilles	0.26	0.12	0.25
		Finelight™ Grilles	0.26	0.12	0.25
		Full Divided Light Grilles	-	-	-
	Low-E4 SmartSun Enhanced w/HeatLock	Without Grilles	0.24	0.13	0.28
		Simulated Divided Light Grilles	0.24	0.12	0.25
		Finelight™ Grilles	0.25	0.12	0.25
		Full Divided Light Grilles	-	-	-

* "Low-E4"; "Low-E4 SmartSun"; "Low-E4 Sun" and "HeatLock" are Andersen trademarks for "Low-E" glass.
1) U-Factor defines the amount of heat loss through the total unit in BTU/hr-ft²-°F. The lower the value, the less heat is lost through the entire product. Window values represent non-tempered glass. Use of tempered glass can increase U-Factor ratings. See andersenwindows.com/nfrc for specific performance values. Door values represent tempered glass. 2) Solar Heat Gain Coefficient (SHGC) defines the fraction of solar radiation admitted through the glass directly transmitted, as well as absorbed and subsequently released inward. The lower the value, the less heat is transmitted through the product. 3) Visible Transmittance (VT) measures how much light comes through a product (glass and frame). The higher the value, from 0 to 1, the more daylight the product lets in over the product's total unit area. Visible Light Transmittance is measured over the 380 to 760 nanometer portion of the solar spectrum.
• NFRC ratings are based on modeling by a third-party agency as validated by an independent test lab in compliance with NFRC program and procedural requirements.
• This data is accurate as of November 2022. Due to ongoing product changes, updated test results, or new industry standards or requirements, this data may change over time. Ratings are for sizes specified by NFRC for testing and certification. Ratings may vary depending on use of tempered glass, different grille options, glass with capillary breather tubes for high altitudes, etc.
• Values are for single units with given pane thickness and 3/4" (19 mm) grilles for windows and door products.

About the Label

Look for this certification label on every window and patio door you buy. The NFRC section was designed by the National Fenestration Rating Council to provide accurate information that helps you promote the energy efficiency of the homes you build. These ratings allow you – and your customers – to measure and compare the energy performance of similar products. If the product does not have this label, the NFRC has not verified its claims.

About the NFRC

The National Fenestration Rating Council (NFRC) is a nonpartisan coalition of professionals whose purpose is to provide fair, accurate and credible energy performance ratings for fenestration products. NFRC's membership includes manufacturers, suppliers, designers, specifiers, utility companies, government agencies and other building industry representatives.

Andersen Corporation is a founding member of the NFRC and continues to support its work by providing fair, accurate and credible energy performance ratings to consumers and the building industry. If you have any questions about the NFRC, its program or energy performance ratings, write them at: NFRC, 6305 Ivy Lane, Suite 410, Greenbelt, MD 20770. Phone: 301-589-1776. Website: nfrf.org

U-Factor indicates how well a product prevents heat from escaping (the lower the number, the better).

Visible Transmittance refers to how much visible light comes through a product (the closer to 1.0, the more light is transmitted).

WDMA Hallmark Certification verifies the performance ratings of this product were tested by an independent testing laboratory and verified by a third-party certification program.

Test Standards

ENERGY STAR Version 7.0 is coming October 23, 2023. For more details, visit andersenwindows.com/energystar.

Do not remove until final code inspection. Save label for future reference.

ENERGY STAR® Certified in Highlighted Regions
Certifié ENERGY STAR dans les régions en surbrillance

Canada
energystar.gc.ca



ENERGY STAR

U.S. / É.U.
energystar.gov



ER/RE 20

DO NOT REMOVE UNTIL FINAL INSPECTION / NE PAS RETIRER AVANT L'INSPECTION FINALE



National Fenestration Rating Council®
CERTIFIED



A-Series Casement Window
AND-N-86-03233-00001
Composite/Wood Combination
Dual-Pane Low-E SmartSun HeatLock Glazing with Argon
Product Type: Casement

ENERGY PERFORMANCE RATINGS

<p>U-Factor</p> <p style="font-size: large;">0.24</p> <p style="font-size: x-small;">(U.S./I-P)</p>	<p>Solar Heat Gain Coefficient</p> <p style="font-size: large;">0.17</p>
<p>Visible Transmittance</p> <p style="font-size: large;">0.40</p>	<p style="font-size: large;">■</p>

Manufacturer stipulates that these ratings conform to applicable NFRC procedures for determining whole product performance. NFRC ratings are determined for a fixed set of environmental conditions and a specific product size. NFRC does not recommend any product and does not warrant the suitability of any product for any specific use. Consult manufacturer's literature for other product performance information.
www.nfrc.org



Hallmark Certified
www.wdma.com

Licensee: 129-H-816
Andersen Corporation
A-Series Casement Window
Manufacturer stipulates Hallmark Certification as indicated below.

STANDARD	RATING
AAMA/WDMA/CSA 101/1.S.2/A440-11	Class LC-PG50 Size Tested 35.3" x 71.3" DP+59-50
AAMA/WDMA/CSA 101/1.S.2/A440-08	Class H-LC50 Size Tested 35.3" x 71.3" DP+59-50
AAMA/WDMA/CSA 101/1.S.2/A440-08 A440S1-09	Class LC-PC50 - 895 mm x 1803 mm Positive/Negative Design Pressure (DP) = +2440/-2440 Pa Water Penetration Resistance Test Pressure = 360 Pa Canadian Air Infiltration Estimation = A3

GLAZING: 3.0mm AN outer/3.0mm AN inner

⚠ WARNING

This product can expose you to chemicals including titanium dioxide, which is known in the state of California to cause cancer, and methanol, which is known to the state of California to cause birth defects or other reproductive harm.
For more information go to www.P65Warnings.ca.gov

Meets or exceeds CEC & IECC Air Infiltration Requirements of 0.2 CFM/sq.ft. or lower.
WDMA Hallmark Certification Program. Complies with HUD UM Bulletin No. 111.

Energy Rating (ER) represents "Energy Rating" and is a rating used in Canada for product comparison purposes (the higher the ER number, the more energy saved during the heating season).

ENERGY STAR® Climate Zone Map is based on U-Factor and solar heat gain coefficient criteria for specific ENERGY STAR climate zones within the United States and Canada. The shading of the map shows which climate zone(s) a particular product and glass type is ENERGY STAR certified in.

Solar Heat Gain Coefficient measures how well a product blocks heat caused by sunlight (the lower the number, the more it will help reduce the use of air conditioning and as a result, reduce electrical bills and energy use).

Performance Grade (PG) and Design Pressure (DP) Ratings

Glass Construction used with this product type.

Combination Designs, Product Performance & Installation

* NFRC ratings are based on modeling by a third-party agency as validated by an independent test lab in compliance with NFRC program and procedural requirements.
** "ENERGY STAR" is a registered trademark of the U.S. Environmental Protection Agency.

INSTALLATION ACCESSORIES

Optional installation accessories are available for the installation of Andersen® windows and patio doors. Keep installation instructions and safety information in mind when considering the installation and use of any Andersen product. For questions, contact your local Andersen supplier.

COIL STOCK



Andersen aluminum coil stock can be ordered to match any of our 11 exterior trim colors. Made from .018" thick aluminum, coil stock is available in 24" (610) x 50' (15240) rolls. Color-matched 1 1/4" (32)-long stainless steel trim nails are also available and can be ordered in 1 lb/454 kg boxes.

FIBREX® TRIM BOARD



Available in the same 11 colors as our exterior trim, this solid cellular Fibrex trim board can be cut or ripped to size, and fastened using nails or screws. 3 1/2" (89) x 3/4" (19) thick in 10' (3048) lengths.

COLOR-MATCHED SEALANT

Color-matched sealant is available in Andersen exterior colors. This high-quality sealant can be used during the installation of all Andersen products.

DRIP CAP

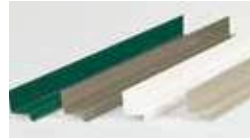

Included on A-Series windows with vertical (ribbon) joins. Heavy 24-gauge corrosion-resistant aluminum construction. Available in 6' (1829), 10' (3048) and 12'-7 1/2" (3848) lengths, and in any of our 11 exterior trim colors.

EXTENSION JAMBS



Available for most Andersen products. See product sections in this guide for details.

VINYL CHANNELS



Rigid vinyl "J" and "h" channels are available in white, Sandtone and Terratone. "J" and "h" channels are 1/2" (13) deep and come in 150" (3810) lengths. "J" channels are 3/4" (19) wide and "h" channels are 1" (25) wide. "H" channels are 3/4" (19) deep and come in 84" (2134) and 150" (3810) lengths. White "H" channels are 3/4" (19) wide. Sandtone and Terratone "H" channels are 1" (25) wide.

INSTALLATION INFORMATION

ROUGH OPENINGS

The purpose of a rough opening is to allow for proper spacing between the window or patio door unit and the building structure. The space is required for locating, leveling and squaring the unit during installation and to provide an area for insulation. A rough opening that is incorrectly sized may affect unit operation and may not allow for adequate fastening of the unit to the building structure. Andersen rough opening dimensions are provided as a guideline to help determine the minimum amount of space needed between the window or patio door and the building structure. See appropriate product sections for rough opening guidelines for each product.

Keep in mind that rough opening dimensions may need to be altered from published guidelines, depending on installation methods, joining methods, replacement methods, etc. For example, flashing systems can reduce the amount of available rough opening space and should be factored in when calculating rough opening dimensions. The use of support or joining materials will encroach on the rough opening and may require additional rough opening space between the unit and the building structure, depending on the thickness of the flashing system and joining materials used. To facilitate drainage, the rough opening sill plate should never slope toward the interior. For challenging environments and other information, refer to EEBA's (Energy and Environmental Building Association) Water Management Guide (www.eeba.org).

IMPORTANCE OF PROPER INSTALLATION

Proper installation and maintenance of Andersen products is essential to attain optimum performance and operation. Installation instructions that provide guidelines for proper installation are typically provided with Andersen products. They are also available by visiting andersenwindows.com. Remember that every installation is different, and Andersen strongly recommends consultation with the local supplier or an experienced contractor, architect or structural engineer prior to the installation of any Andersen product. The method of attachment for Andersen products, fastener selection and code compliance is the responsibility of the architect, building owner, contractor, installer and/or consumer. For more complete installation details, visit andersenwindows.com or see your Andersen supplier.

GENERAL NOTES

When ordering, make certain you specify, then verify, the exact product, unit dimensions, configuration requirements, color and options you desire on each window or patio door. Before installing the product, we suggest you verify that it includes the features and options you ordered. Visit andersenwindows.com for product installation and joining guides. Printing limitations prohibit exact color duplication of products. View actual samples for building specifications. Andersen Corporation reserves the right to change details, specifications or sizes without notice. The customer assumes all risk of alterations made to Andersen products.

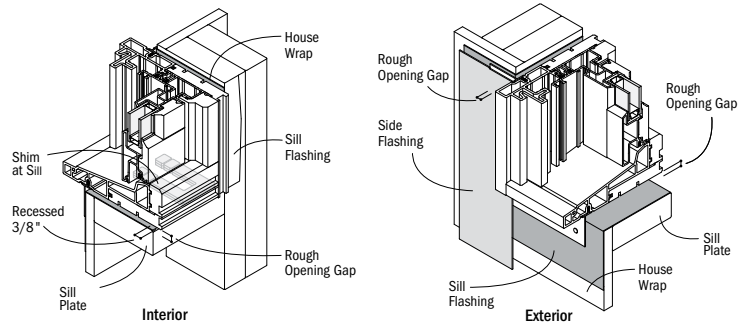

Example of window sill flashing in a membrane drainage system.

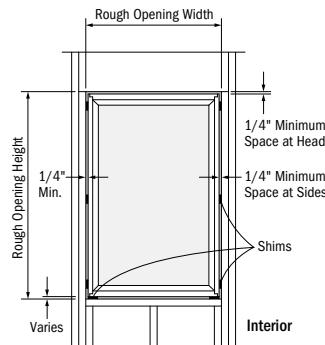

Example of window unit installed using Andersen published minimum rough opening dimensions.

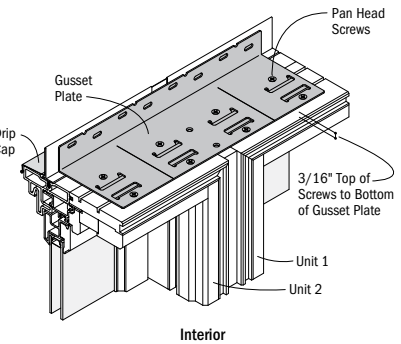

Example of two units joined together with the use of gusset plates and pan head screws that will require additional rough opening space.

Dimensions in parentheses are in millimeters.

CODES

Appropriate selection of Andersen products that conform to all applicable laws, ordinances, building codes and safety requirements is the sole responsibility of the architect, designer, building owner and/or contractor. Check with your local building code officials for specific information. Unit wind load, performance grade and energy performance information is provided on pages 196-225. For up-to-date product performance information, visit andersenwindows.com. The performance of any building system depends on the design and construction of the building system in its entirety, which should meet building code requirements, as well as address product and material limitations, and local environment and climate.

DRIP CAPS

Drip caps are a specific type of flashing or trim used at the head of a window or door to direct water from the drainage plane out beyond the face of the unit.

FLASHING

Flashing is an important element in a building's water management system. It is used to shed and direct water to the building exterior or to the drainage plane. Flashing materials are typically applied starting from the bottom and working upward, with each successive layer overlapping the previous one in shingle fashion. Water infiltration problems in any type of building can be reduced by properly flashing and/or sealing around all building openings, including windows and doors.

USE OF SHIMS

Shims are used along the side jambs of windows and doors to center the unit in the rough opening and to position it plumb, level and square. In addition, shims are always required for windows under the sill at the side jambs to lift it off the rough opening sill plate. Shims also enable a straight frame for proper weatherstrip contact and unit operation. If not placed properly, unit performance and operation can be affected. Use waterproof shims capable of supporting the weight of the product. When using tapered shims, use them in pairs with the tapers opposing each other to avoid tilting the unit or twisting (rotating) of the jambs.

SEALANTS

Sealants are elastic materials used to block the passage of water and/or air while allowing movement between the two sides of the joint. A sealant should bond tightly, and be able to expand and contract to accommodate joint movement without cracking or tearing away from the substrate. Surfaces must be clean, dry and sound for adequate sealant adhesion. Choose a sealant that is compatible with, and that will adhere adequately to, all building materials used in the window and patio door area. Proper sealant joint design is based upon the expected movement of adjacent materials and the movement capability of the sealant. A general rule of thumb is that the depth of the sealant joint should be equal to half the width ($D = W/2$), but generally not less than $1/4"$ (6) or more than $1/2"$ (13). Foam-plastic backer rod can be used to limit the depth of the sealant joint, to provide a backstop for tooling the sealant without damage to the bond. It also acts as a bond breaker to help minimize stress in the sealant. Sealants should be maintained seasonally, and repaired and/or replaced as needed.

Dimensions in parentheses are in millimeters.

GENERAL INSTALLATION GUIDELINES

1. Read and follow the installation guide in its entirety.
2. Decide whether you are integrating to a surface barrier or a membrane drainage system before installing the product. The appropriate method for your installation may vary based on building design, application and industry practices.
3. Make certain the drainage plane is continuous (proper overlaps to shed water, taped seams, etc.).
4. Andersen products should be installed only in the vertical position.
5. Check the rough opening to make sure it is sized properly, is square and is level.
6. Install the window or door plumb.
7. Install the window or door level.
8. Install the window or door square. Diagonal measurements should be within $1/8"$ (3).
9. Follow installation instructions to properly locate shims and to make sure that units are plumb, level and square. Shims are always required under the window jambs at the sill and along the jambs on the sides for windows and doors.
10. Check for squareness of unit before final anchoring of the product into the wall.
11. Anchor unit as directed with appropriate fasteners.
12. Integrate the window and door into the drainage plane of the wall using quality flashing and sealing materials. All flashing materials should be properly overlapped to shed water.
13. Allow $1/4"$ (6) minimum space for a sealant joint around perimeter of unit between exterior finish materials and unit.
14. Insulate and seal the interior cavity between the window or door frame and the rough opening.
15. Check operation before application of interior trim.
16. Stain and/or seal all unfinished wood surfaces promptly to minimize moisture absorption.

EXTERIOR PAINTING/SEALING OF ANDERSEN® PRODUCTS

The exterior of some Andersen products may be painted or stained. However, improper painting and staining may cause damage to vinyl, aluminum and other exterior materials.

CAUTIONS

1. Do not apply any type of film to insulating glass. Thermal stress and glass damage can result. Andersen Corporation is not responsible for product performance when films are applied to Andersen products.
2. The use of removable insulating materials such as insulated window coverings, shutters and other shading devices may also cause thermal stress conditions and/or deformation of protective vinyl. In addition, excessive condensation may result, which can have a deteriorating effect on the window or door unit(s) involved. Andersen Corporation is not responsible for product performance when these kinds of materials or devices are applied to or used in conjunction with Andersen products.

SAFETY GLASS

Unless specifically ordered, Andersen windows are not made with safety glass and, if broken, the glass could fragment, causing injury. Andersen windows may be ordered with tempered glass which may reduce the likelihood of injury when broken. All Andersen patio doors are made with tempered glass. Differences in appearance between tempered and non-tempered glass can be expected. Slight visual distortions may be noticeable and occur normally as a result of the tempering process. Building codes require safety glass in locations adjacent to or near doors and other locations.

WINDOW AND PATIO DOOR SAFETY

Windows may provide a secondary avenue of escape or rescue in an emergency, such as a fire. Every family should develop an escape plan and make sure family members know how to escape from the home in an emergency. In your plan, include two ways to escape from every room in case one way is blocked by fire or smoke, and make sure you have a designated meeting place outside. A window or a patio door is an alternate means of escape or rescue. Practice your plan until each member of the family understands it and is able to escape without assistance. Remember, you may not be able to reach children during a fire emergency. Teach children – even very young children – that they must escape from a fire in the home and never hide from the fire or from emergency personnel.

LOOKOUT FOR KIDS® PROGRAM

The Consumer Product Safety Commission has said: "Keep children away from open windows to prevent falls. Don't depend on insect screens to keep the child from falling out of the window. They are designed to keep insects out, not children in. Avoid placing furniture near windows to keep children from climbing to a window seat or sill." In an effort to educate consumers about the potential for child falls from windows, Andersen Corporation created the LookOut For Kids Program. It combines a window and door safety brochure and specific product instructions to help make window and door safety an important priority for consumers. For more information on child safety, write:

Andersen Corporation
LookOut For Kids Program
 100 Fourth Avenue North
 Bayport, MN 55003
 Call 800-313-8889 or email
lofk@andersencorp.com

**LOOK
 OUT!**
 for kids®

Andersen® windows and patio doors can make significant contributions to the success of sustainable design strategies

As a charter member of the U.S. Green Building Council, we're active supporters of certified green buildings. Our products can help customers in pursuing green building programs, such as Leadership in Energy and Environmental Design (LEED®), the National Green Building Standard, Green Globes, GreenStar and more. Below is an overview of how our products may assist project teams with pursuing LEED v4 or the NAHB National Green Building Standard rating systems. More detailed credit summaries, as well as information about how Andersen products can support earlier versions of LEED certification (e.g., LEED v3 or LEED 2008), are available at andersenwindows.com.

LEED V4 FOR BUILDING DESIGN AND CONSTRUCTION: NEW CONSTRUCTION AND MAJOR RENOVATIONS

Integrative Process Credit:

Energy & Atmosphere

- Minimum energy performance prerequisite
- Optimize energy performance credit
- Renewable energy production credit
- Green power and carbon offsets credit

Materials & Resources

- Construction and demolition waste management planning credit
- Building product disclosure and optimization sourcing of raw materials credit
- Construction and demolition waste management credit

Indoor Environmental Quality

- Minimum indoor air quality performance prerequisite
- Minimum acoustic performance prerequisite – schools
- Enhanced indoor air quality strategies credit
- Low-emitting materials credit
- Thermal comfort credit
- Daylight credit
- Quality views credit
- Acoustic performance credit (option 2)

LEED V4 FOR BUILDING DESIGN AND CONSTRUCTION: HOMES AND MULTI-FAMILY MIDRISES

Energy & Atmosphere

- Minimum energy performance prerequisite
- Education of the homeowner, tenant or building prerequisite
- Annual energy use credit
- Building orientation for passive solar credit
- Air infiltration credit
- Windows credit

Materials & Resources

- Durability management prerequisite
- Environmentally preferable products credit
- Construction waste management credit

Indoor Environmental Quality

- Ventilation prerequisite
- Low-emitting products credit

ANSI ICC/ASHRAE 700-2015 NATIONAL GREEN BUILDING STANDARD

NGBS section numbers are referenced in parentheses.

Resource Efficiency

- Prefinished materials (601.7)
- Flashing (602.12)
- Exterior doors, including storm doors (602.1.10)
- Recycled construction materials (605.3)
- Bio-based products (606.1)
- Wood-based products (606.2)
- Manufacturer's environmental management system concepts (611.1)

Energy Efficiency

- Mandatory requirements (701.1)
- Building thermal envelope air sealing (701.4.3.1)
- Multi-family air leakage alternative (701.4.3.3)
- Fenestration air leakage (701.4.3.4)
- ICC IECC analysis (702.2.1)
- Energy performance analysis (702.2.2)
- UA improvement (703.2.1)
- Fenestration (703.2.5)
- Sun-tempered design (703.7.1)
- Passive cooling design (703.7.3)
- Passive solar heating design (703.7.4)

Indoor Environmental Quality

- Wood materials (901.4)
- Interior architectural coatings (901.9)
- Interior adhesives & sealants (901.9)
- Operable windows & sliding glass doors (902.1.5)

Energy Efficient

- Homeowner's manual (1001.1)
- Building construction manual (1002.1)



THE ENVIRONMENT HAS A BUSINESS PARTNER

Respect for the environment is nothing new at Andersen. For more than a century, it has been part of who we are. Our commitment to recycle and reclaim materials began simply because it was good business. Now it's part of our broader commitment to sustainability and responsible stewardship of all of our resources. Andersen is committed to providing you with long-lasting,* energy-efficient windows and patio doors. Visit andersenwindows.com/sustainability for more information.

Andersen® products are certified under the National Fenestration Rating Council (NFRC) voluntary third-party certification program designed to ensure accurate energy performance ratings and labeling.



Andersen was one of the first U.S. window manufacturers to receive the Forest Stewardship Council® (FSC®) Chain-of-Custody certification (FSC CO16636). This certification is awarded to companies that meet FSC standards for traceability in their wood supply chain. Ask your sales representative about the availability of FSC certified products.



The Window & Door Manufacturers Association (WDMA) Hallmark Certification program includes product testing and quality-control process audits to verify that Andersen windows and doors are produced in conformance with the industry standards for air, water resistance and structural performance.



Andersen Corporation is proud to be an ENERGY STAR® partner. For over 115 years, Andersen has built a reputation for environmental stewardship and energy-efficient products. In fact, Andersen has been part of the ENERGY STAR program since it started and was the first window manufacturer to be named an ENERGY STAR National Window Partner of the Year in 1999.



Andersen A-Series casement, awning and fixed transom products are Phius (Passive House Institute US) certified products. Phius is the smartest path to a zero-carbon built environment, certifying the majority of all passive house projects in North America with locally tailored, globally applicable passive building standards.

*Visit andersenwindows.com/warranty for details.

All logos and marks are trademarks of their respective owners.

Welcome to an overview of the enhanced navigation tools available in this PDF. Here are some simple tips on PDF navigation. Before you begin be sure you are using the latest version of Adobe Acrobat Reader DC, available at – <https://get.adobe.com/reader/>

To watch a 3-minute tutorial on navigating catalog PDFs, go to: <https://youtu.be/sWWnYn60N3Y>

BOOKMARK NAVIGATION

①

Acrobat will display the bookmarks panel when you open the PDF.

Bookmarks are the easiest way to find specific product information.

Select a topic and that page will be displayed.

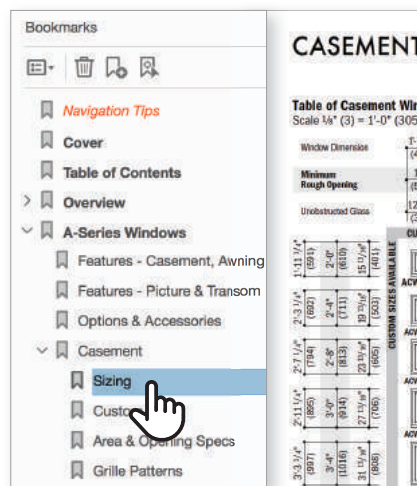

②

If you need to print a specific section, **right click on that section** within in the bookmarks panel and choose **“Print Section”**.

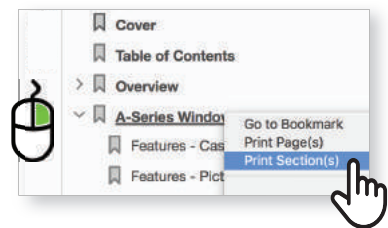

LINKS AND URL NAVIGATION

①

You can also use the **embedded links** to navigate between sections. All links are underlined in blue.



②

Website links automatically open in your web browser.



PDF NAVIGATION TIPS Cont.

Add additional navigation tools by adjusting the default settings in Acrobat.

← → TOOL BAR NAVIGATION

1

To add a **“Jump Back” Button** to your tool bar, **right click on tool bar**, select **Show Page Navigation Tools** and choose **Show All Page Navigation Tools**.

Right and left facing arrows are added to the tool bar allowing you to go back or forward to the last page you viewed.

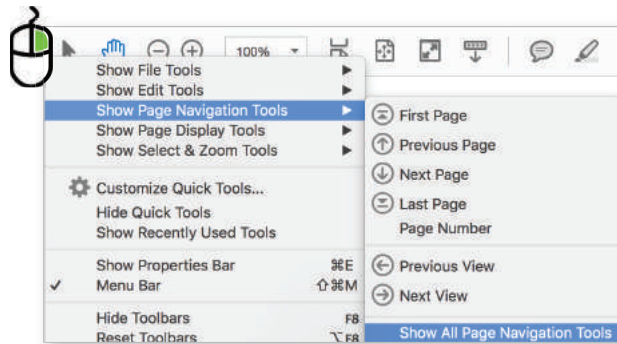

2

Another helpful tool is the **Loupe Tool**.

It allows you to zoom in on the page without having to increase the page size.

To add a **Loupe Tool** to your tool bar, **right click on tool bar**, select **Show Select & Zoom Tools** and then choose **Show All Select & Zoom Tools**.

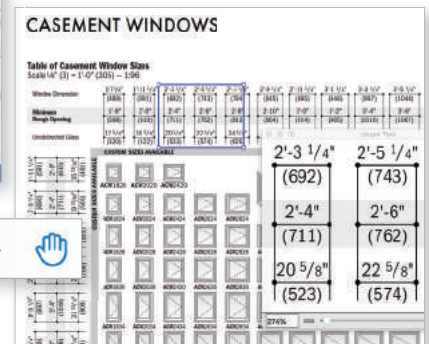
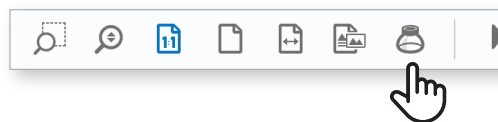
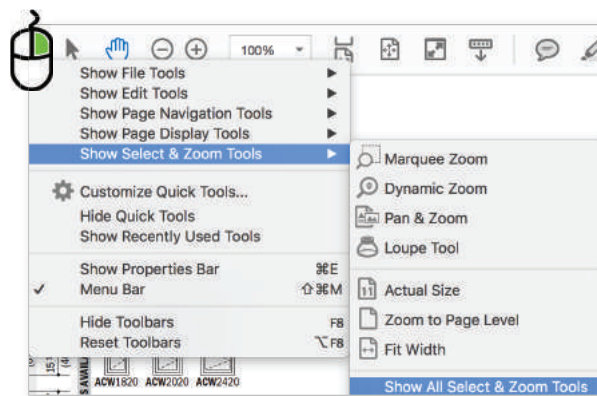

3

You can also use the **commenting tools**.

Add a post-it note with your comments or highlight important information.

Be sure to save the file.

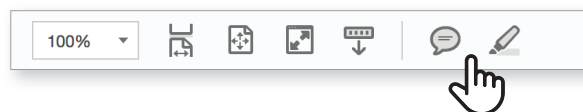

To watch a 3-minute tutorial on navigating catalog PDFs, go to: <https://youtu.be/sWWnYn60N3Y>

We are always looking for ways to improve.

Please send feedback to webmarketing@andersencorp.com.